

Review of Soft Launch Opportunity

Distribution Planning Working Group

August 8, 2019



Hawaiian Electric
Maui Electric
Hawai'i Electric Light

Agenda

Objective:

- ◆ Provide overview of DPWG's activity to-date
- ◆ Discuss soft launch opportunities and associated engineering analysis and needs identification

Agenda:

- ◆ Introductions and Overview
- ◆ Soft Launch Purpose and Objectives
- ◆ Distribution Needs Assessment Process
- ◆ Soft Launch NWA Opportunity Identification
 - ◆ Ho'opili Analysis and Opportunity
 - ◆ East Kapolei Analysis and Opportunity
- ◆ Soft Launch RFP Schedule
- ◆ Next Steps



Ground Rules

- ◆ Chatham House Rule will apply – no personal or organizational attribution will be made to any comments/feedback provided during the meeting by any participant nor in written documentation.
- ◆ Working group meetings, and other information exchanges are intended solely to provide an open forum or means for the expression of various points of view in compliance with antitrust laws.
- ◆ Under no circumstances shall engagement activities be used as a means for competing companies to reach any understanding, expressed or implied, which tends to restrict competition, or in any way, to impair the ability of participating organizations to exercise independent business judgment regarding matters affecting competition or regulatory positions.
- ◆ Proprietary information shall not be disclosed by any participant during any industry engagement meeting or information exchange. In addition, no information of a secret or proprietary nature shall be made available to industry engagement participants.
- ◆ All proprietary information which may nonetheless be publicly disclosed by any participant during any industry engagement meeting or information exchange shall be deemed to have been disclosed on a non-confidential basis, without any restrictions on use by anyone, except that no valid copyright or patent right shall be deemed to have been waived by such disclosure.



Overview

IGP WGs have focused on several aspects to advance NWAs

- ◆ Surveyed best practices across U.S. for NWA processes and methods for opportunity identification, procurement (incl. reference RFPs) and proposed solution evaluation
 - ◆ Utility and stakeholder presentations
 - ◆ Research on regulatory and legislative guidance in other states
- ◆ Identify and define new NWA services
 - ◆ Distribution Capacity Service
 - ◆ Reliability (Back-tie) Service
- ◆ Identify & evaluate candidate opportunities for Soft Launch NWA
 - ◆ Ho'opili Detailed Needs Analysis & Requirements
 - ◆ East Kapolei Detailed Needs Analysis & Requirements
- ◆ Develop NWA RFP for Soft Launch and beyond
- ◆ Develop ongoing process for identifying and evaluating opportunities, sourcing approaches and evaluation methods



Soft Launch Purpose & Objectives

Purpose:

- ◆ A soft launch of the sourcing process will help inform development of the full scale IGP planning and sourcing effort beginning in 2020.

Objectives:

- ◆ IGP Soft Launch is intended to demonstrate the sourcing processes and evaluation methods for distribution non-wires alternatives in 2019.
- ◆ A Soft Launch project will provide real-world experience associated with the identification of needs for a resource choice like aggregated DER because of locational impacts of DER
- ◆ This process will also work to address concerns with transparency and access to information among the working groups.
- ◆ Soft Launch is focused on one distribution substation capacity deferral need that can be reasonably addressed by NWA.
- ◆ Soft Launch will commence with sourcing and evaluation in 2019 and continue with anticipated solution deployment in 2020-21 and operational testing by 2022.

Source: IGP Workplan

Soft Launch Demonstration Scope

- ◆ Identify distribution capacity deferral service for demonstration
 - ◆ Identify a distribution opportunity that has sufficient value and performance requirements that may be met by a variety of potential NWA providers
 - ◆ Distribution NWAs have several different requirements and considerations that need to be explored
 - ◆ As such, not seeking procurement of other services as part of NWA demonstration to focus on successful implementation and incorporate learnings into IGP
 - ◆ Other current opportunities for ancillary services
- ◆ Identify deferral opportunity that can be operational by 2022
 - ◆ Goal to inform IGP NWA sourcing & evaluation in 2020
 - ◆ Provide adequate time for implementation of providers' solution and testing
 - ◆ Goal inform implementation stage of IGP
- ◆ DER technology agnostic and will consider provider solutions behind the meter and/or ahead of meter
 - ◆ Providers may make multiple solution proposals or combinations of proposals to satisfy the distribution need



Soft Launch NWA Solution Considerations

- ◆ Aggregations of DER or standalone resources
- ◆ Solutions can be in front-of-the-meter and/or behind-the-meter
 - ◆ Behind-the-meter DER must have an executed Interconnection Agreement
- ◆ DER must be located within and interconnected to the eligible circuit(s)
- ◆ Proposed DER for Soft Launch must be incremental to existing programs, tariffs, or PPAs
 - ◆ Completely new asset or add-on to an existing asset
 - ◆ Existing assets compensated under an existing program like NEM or under a grid services procurement will not be eligible
- ◆ To manage complexity and risk consideration of a minimum size and DER provider diversity may be needed



Anticipated Soft Launch Learnings

- ◆ NWA opportunity and solution parameters/criteria to enable successful proposals that provide operational effectiveness.
- ◆ NWA evaluation considerations, beyond price (in relation to avoided cost)
- ◆ Insights on operational risks and factors such as NWA reserve margins
- ◆ Information exchange needed
- ◆ How other sourcing options, such as programs and pricing may support NWAs



Distribution Needs Assessment Process



Hawaiian Electric
Maui Electric
Hawai'i Electric Light

Grid Needs Assessment

- ◆ Distribution Planning Process
 - ◆ High level planning process description
 - ◆ Important planning concepts
- ◆ Study Objectives and Scope
- ◆ Methodology of Analysis
- ◆ Defined NWA Services
- ◆ West Region Planning Area Distribution Needs Assessment
 - ◆ Ho'opili Area Review
 - ◆ East Kapolei Area Review



Distribution Planning Process

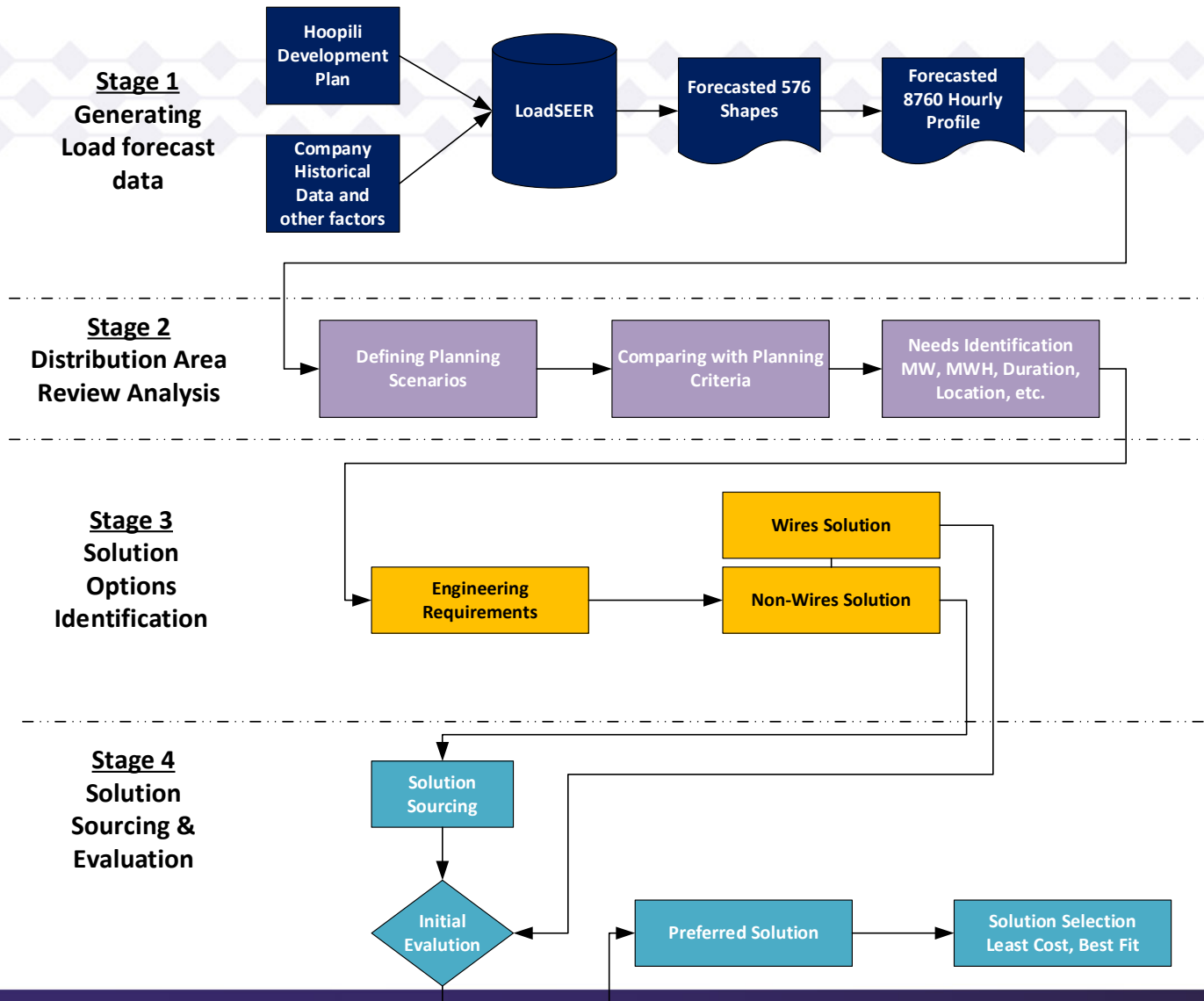

Distribution Planning Criteria

- ◆ Important Planning Concepts – Planning Criteria
 - ◆ Company's equipment loading criteria
 - ◆ Substation transformer
 - ◆ Normal condition thermal (kVA) rating and contingency condition kVA rating
 - ◆ Contingency condition rating is 1.1x to 1.4x of normal condition kVA rating.
 - ◆ Distribution circuit
 - ◆ Normal condition – normal rating ampacity
 - ◆ Contingency condition – emergency rating ampacity
 - ◆ Contingency condition rating is 1.1x to 1.4x time of normal contingency kVA rating.
 - ◆ Other criteria
 - ◆ Voltages
 - ◆ Power Quality



Typical HECO Distribution Transformer/Circuit Arrangement

◆ Typical 46-12kV Transformer and Circuit

- ◆ 10/12.5 MVA Transformer Size
- ◆ Two 12kV Circuits per transformer
- ◆ Approximately 3-6 MVA loading per circuit

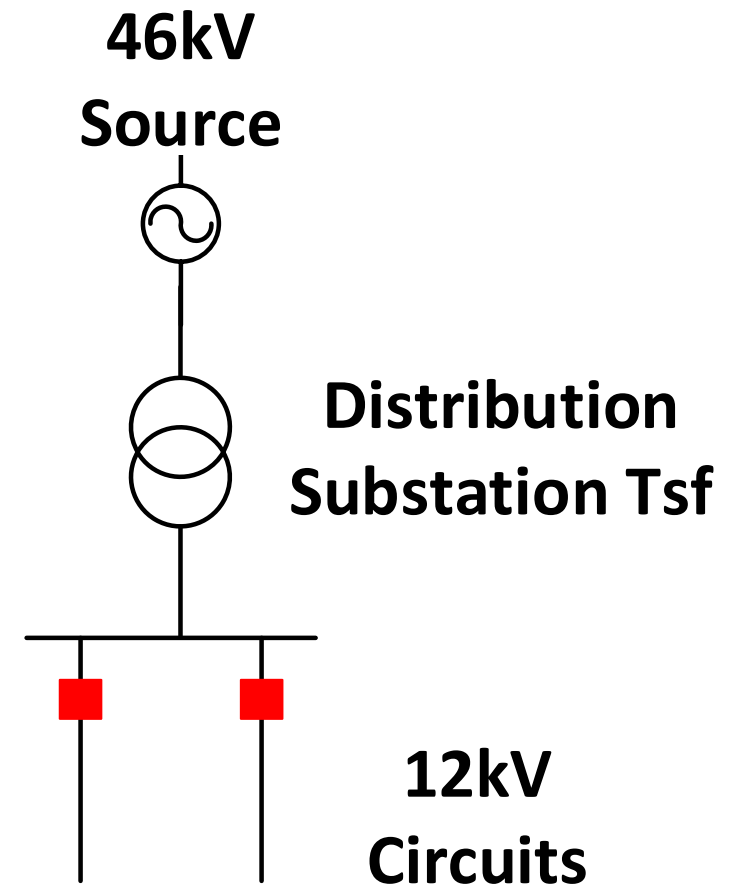

Distribution Planning Process – Planning Concepts

Normal Condition

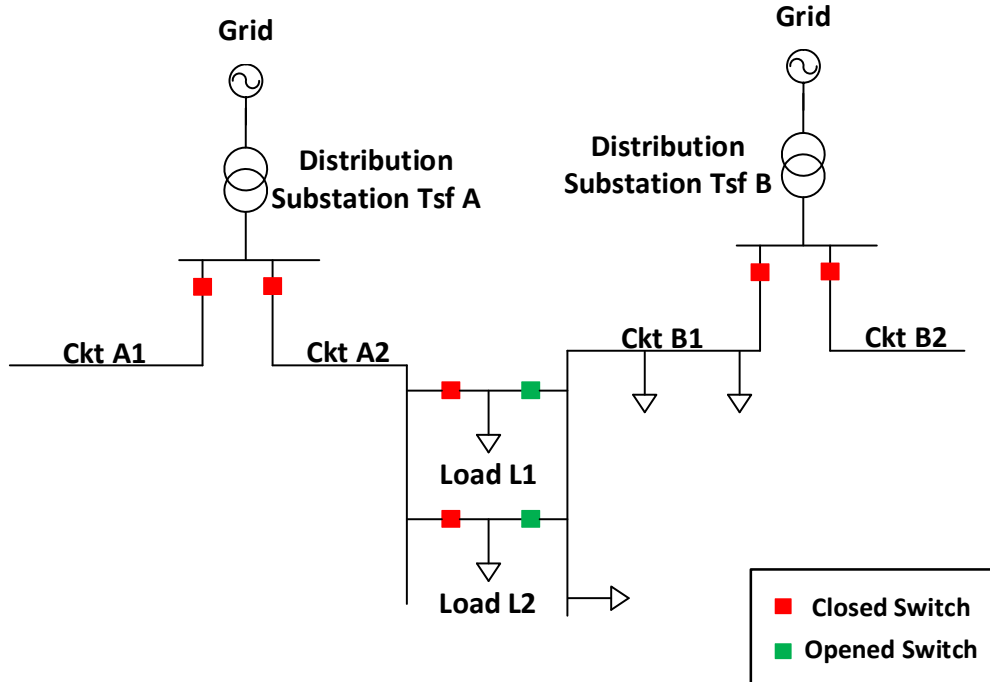

Contingency Condition

Unplanned outages (i.e., electrical faults, weather, motor vehicle accidents, etc.)

Planned outages (i.e., maintenance, construction, etc.)

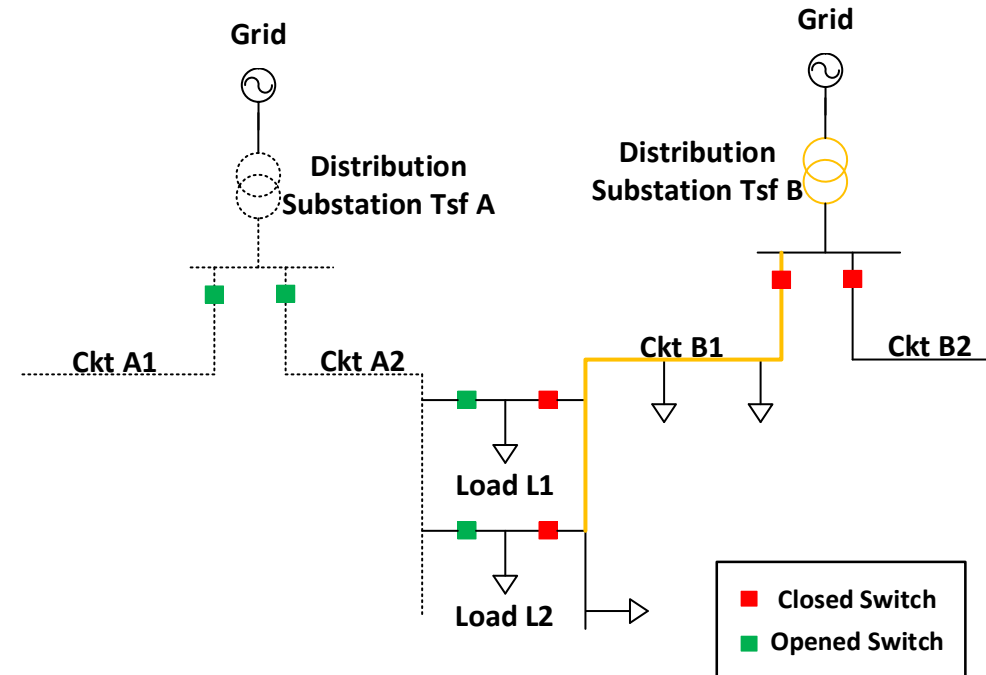

Underground Distribution Circuit Design

- ◆ Underground distribution systems such as those in East Kapolei and Ho'opili, have low restoration times through auto-transfer schemes
- ◆ In this area, when an outage occurs on the underground circuit the loads served by a circuit will automatically transfer to a back-up circuit within 12 seconds
- ◆ This is important to note when planning underground circuits – the back-up circuit must be ready to accept an influx of load should a transfer occur



Study Objectives and Scope

- ◆ Identify distribution system needs and related engineering requirements
- ◆ Identify options to mitigate the planning criteria violations
 - ◆ Potential NWA opportunities and performance requirements
 - ◆ Traditional “wires” solutions



Methodology of Analysis

- ◆ New load energized at beginning of every year
- ◆ 8760 hourly profile generated from 576 shapes from LoadSEER load forecast [Industry leading forecasting tool]
 - ◆ Historical SCADA data
 - ◆ Load projections provided by customers and developers
 - ◆ Utilized LoadSEER's 1 day in 2 year hottest weather day forecast 576 shapes to populate 8760 hourly curve for each year from 2019 to 2030.
 - ◆ *Industry practice is to use a more conservative approach: 1 day in 10 year forecast*
 - ◆ Load power factor assumption (0.95)
- ◆ Planning scenarios considered in the study per Planning Criteria
 - ◆ Normal conditions
 - ◆ Contingency conditions
- ◆ Study Period: 5-10 Year



T&D Non-Wires Alternative Definition

NWA Definition:

An electricity grid project that uses non-traditional transmission and distribution (T&D) solutions, such as distributed generation (DG), energy storage, energy efficiency (EE), demand response (DR) and grid software and controls, to defer or avoid the need for conventional transmission and/or distribution infrastructure investments.

Sources: Adapted from Navigant, DOE and E4TheFuture, PLMA & SEPA, Non-wires Alternatives: Case Studies from Leading US Projects



Distribution Service Definitions

Distribution Capacity Service:

A supply and/or a load modifying service that DERs provide as required via the dispatch of power output for generators and electric storage, and/or reduction in load that is capable of reliably and consistently reducing net loading on desired distribution infrastructure. Distribution Capacity service can be provided by a single DER resource and/or an aggregated set of DER resources that reduce the net loading on a specific distribution infrastructure location coincident with the identified operational need in response to a control signal from the utility.

Reliability (Back-Tie) Service:

A supply and/or load modifying service capable of improving local distribution reliability under abnormal conditions. Specifically, this service reduces contingent loading of grid infrastructure to enable operational flexibility to safely and reliably reconfigure the distribution system to restore customers.

Source: Adapted with HI stakeholder feedback on references from California PUC IDER & DRP Dockets



NWA Performance Parameters

- ◆ MW/MVA size
 - ◆ Mitigate the year's worst scenario with a percent margin
- ◆ Daily duration in hour
 - ◆ Based on the year's longest daily duration.
- ◆ Delivery month
 - ◆ When planning criteria violations occurs.
- ◆ Delivery days
 - ◆ Requires all week days of a week if overloading issue is identified on any week day of the week.
 - ◆ Requires all weekend days of a week if overloading issue is identified on any weekend day or holiday of the week.
- ◆ Max. number of calls per year
 - ◆ Total number of days required per above rules for overloading mitigation, and at least one month of week days or weekend days, if mitigation is only required for week day or weekend day.



Soft Launch Opportunity Identification



Hawaiian Electric
Maui Electric
Hawai'i Electric Light

West Region Planning Area Distribution Needs Assessment

- ◆ Ho‘opili Area Distribution Capacity Study
 - ◆ Load growth description
 - ◆ Distribution transformers and circuits involved in the study
 - ◆ Planning criteria violation summary
 - ◆ Mitigation plan
- ◆ East Kapolei Area Distribution Capacity Study
 - ◆ Load growth description
 - ◆ Distribution transformers and circuits involved in the study
 - ◆ Planning criteria violation summary
 - ◆ Mitigation plan





Ho'opili Area Capacity Study

- ◆ Driven by future Ho'opili Subdivision development
- ◆ Address system needs to accommodate new loads



Inputs and Assumptions

◆ Forecast Assumptions

- ◆ New loads: New load estimates were provided by the developer for the Ho‘opili project
- ◆ Actual electric service requests provide higher certainty to forecast
 - ◆ Main driver for identifying needs and initiating distribution investments
- ◆ These loads were added to LoadSEER as residential, commercial, or industrial load types.
- ◆ If the type of load was not provided, it was given a flat (constant) load profile, meaning that the load did not vary over the course of a day. Specialized loads like rail power stations.
- ◆ Load growth: Load growth is calculated in LoadSEER by blending the corporate forecast and geospatial factors in addition to developer load projections and electric service requests
- ◆ Initial phases of Ho‘opili already being served by existing distribution infrastructure



Load Shapes Used to Develop Load Forecast

Residential Load Shape

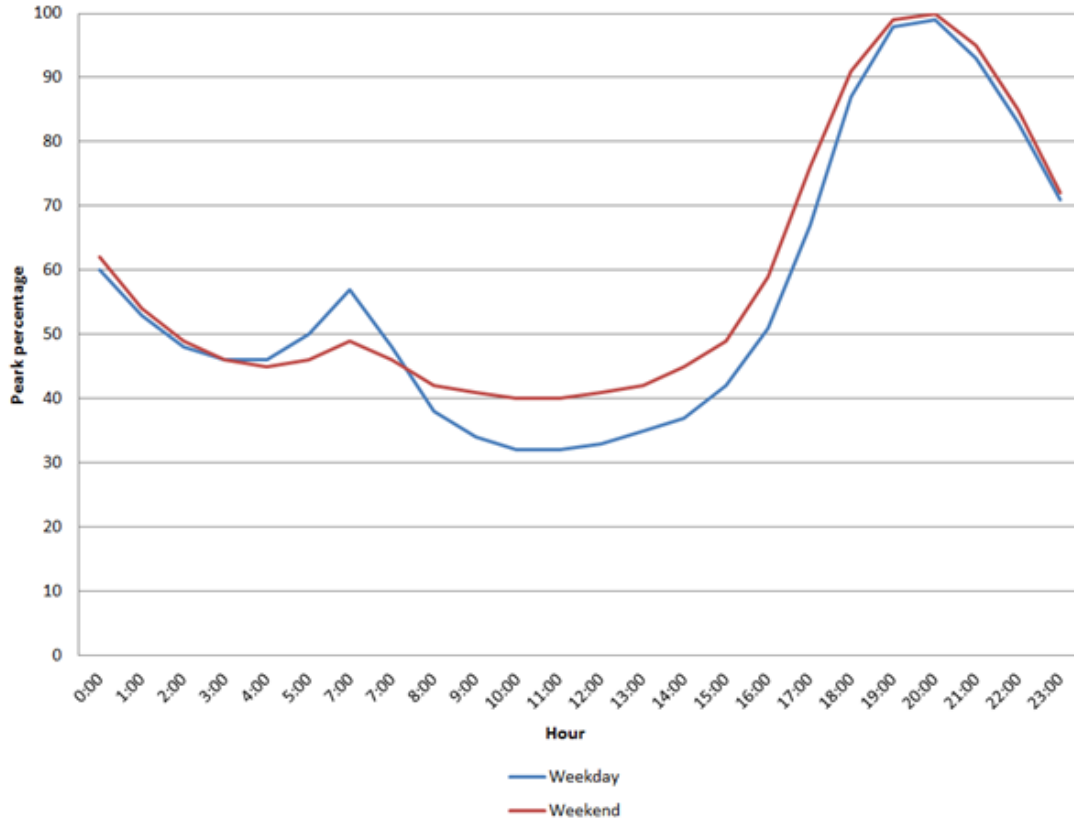

Commercial Load Shape



DER Assumptions in the Area Serving Ho‘opili

Equipment	Existing DER (MW)
Ewa Nui 2 Circuit	3.0
Ewa Nui 3 Circuit	–
Ewa Nui 2 Transformer	3.0
Kaloi 1 Circuit	0.5
Kaloi 2 Circuit	–
Kaloi 1 Transformer	0.5
Kaloi 3 Circuit	–
Kaloi 4 Circuit	–
Kaloi 2 Transformer	–
Kamokila 3 Circuit	0.8
Kamokila 4 Circuit	1.9
Kamokila 2 Transformer	2.7
Kapolei 3 Circuit	–
Kapolei 4 Circuit	1.2
Kapolei 2 Transformer	1.2
Total	7.4



Ho'opili Area Capacity Study

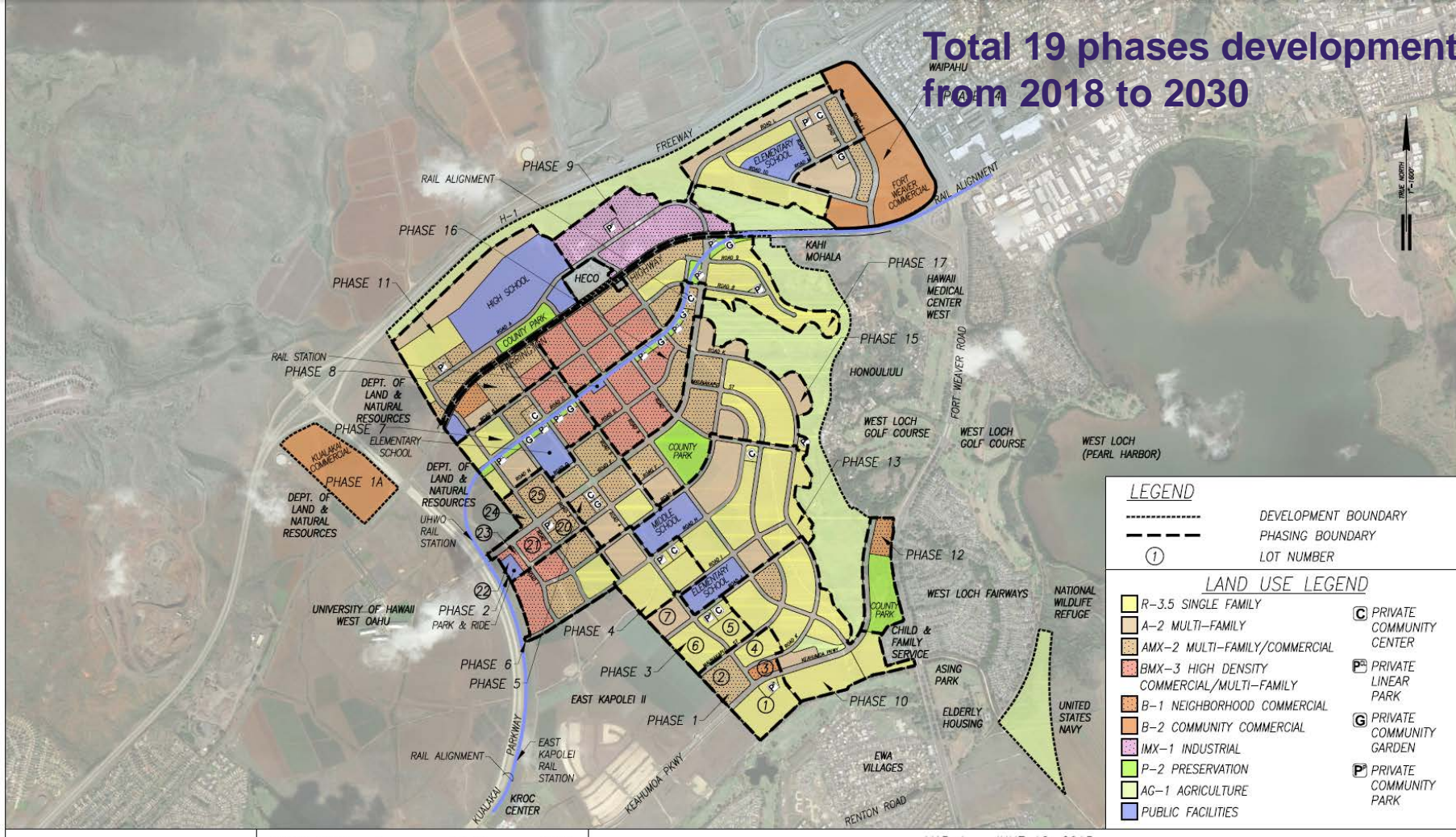

Ho'opili Customer Composition

2019-2024 New Residential Units

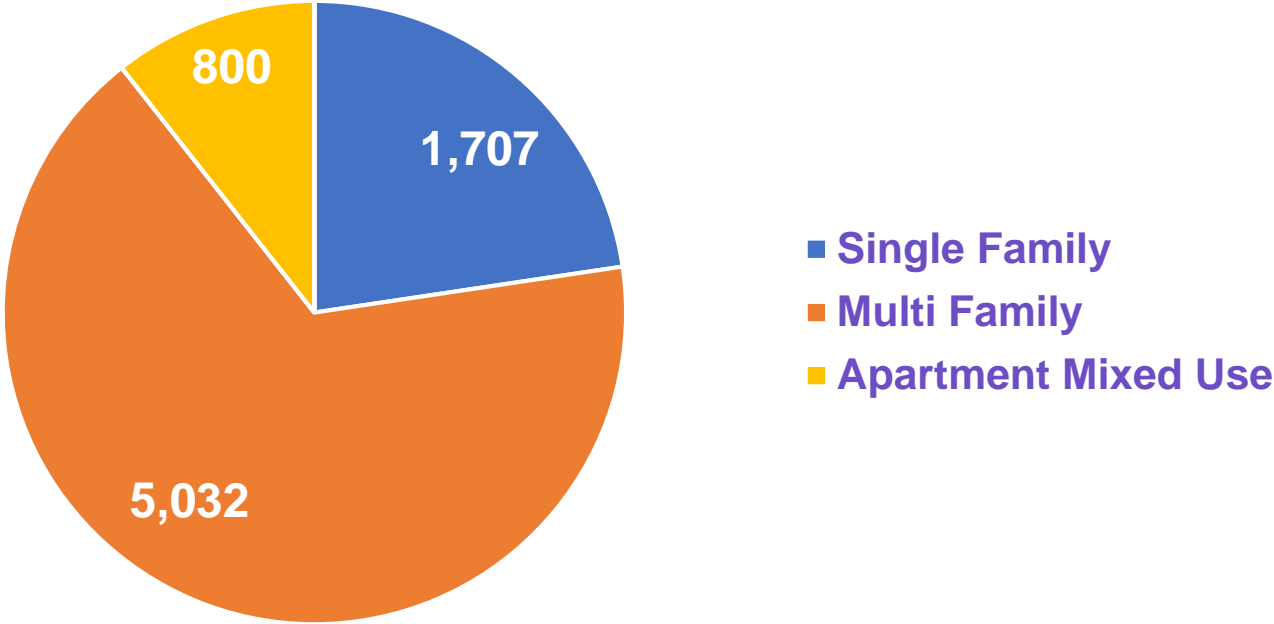

Existing Residential Customers Hoopili Phase 1 and 3

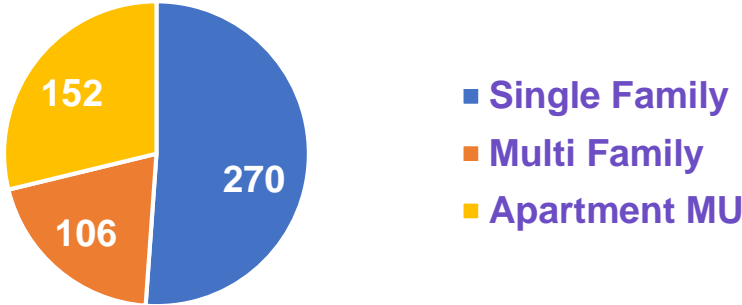

Approximately 10% of existing Ho'opili customers have adopted PV - 532 kW

Ho'opili Customer Load Composition

2019-2024 Projected Load by Type (kVA)

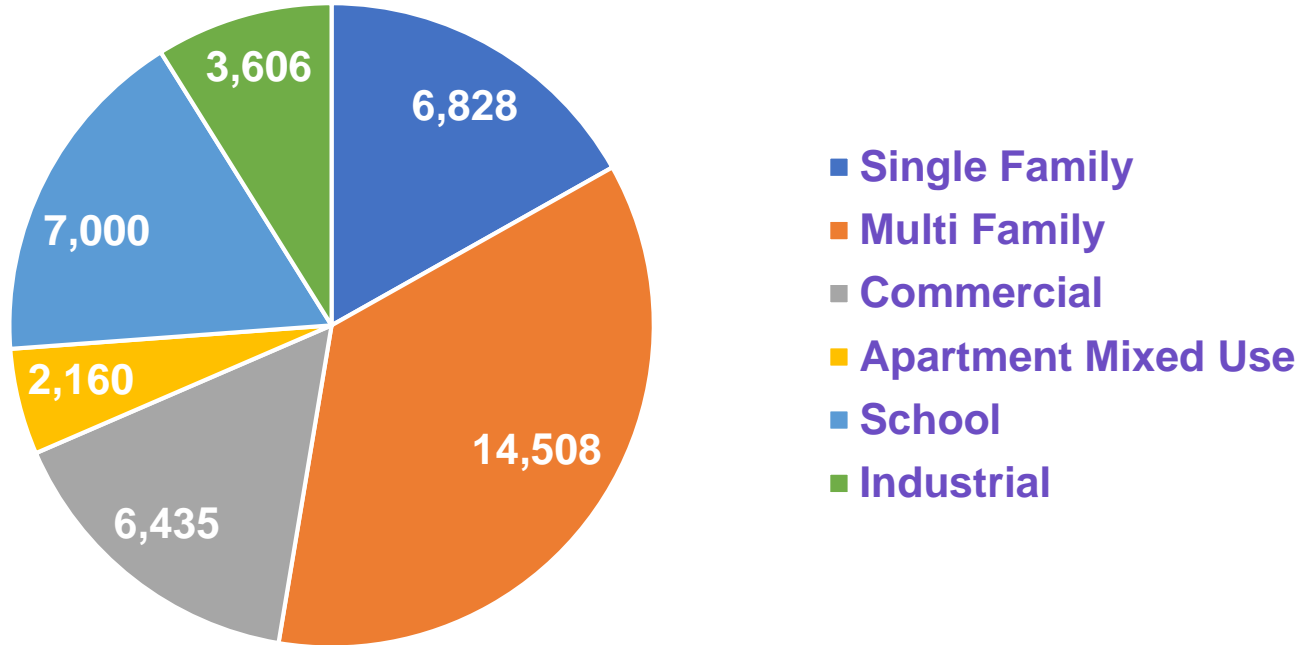

Existing Load by Type (kVA)
Ho'opili Phase 1 and 3

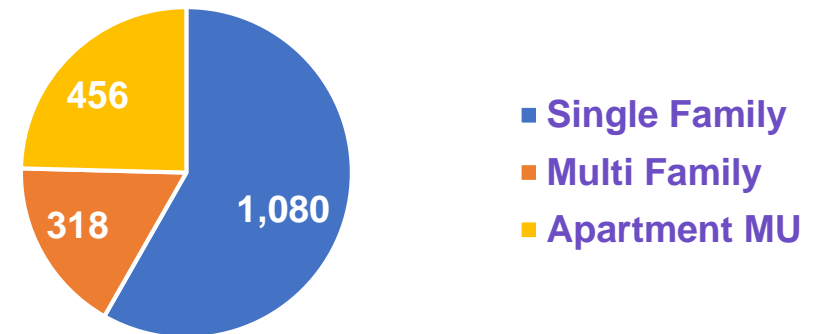

Approximately 10% of existing Ho'opili customers have adopted PV - 532 kW



NWA Potential Considerations

- ◆ Other NWA opportunities across industry
 - ◆ Large existing customer (count) base used to provide NWA services to mitigate smaller number of customers driving growth
 - ◆ Ho‘opili has small to none existing customer base and large number of customers driving growth
- ◆ Ho‘opili Situation
 - ◆ Existing phases served by existing distribution is nearing capacity
 - ◆ Starting in 2022 load projections show overloading of equipment
 - ◆ Significant additional capacity or load reduction needed in future years to meet obligation to provide electric service



Ho'opili Area Capacity Study – Affected Substations

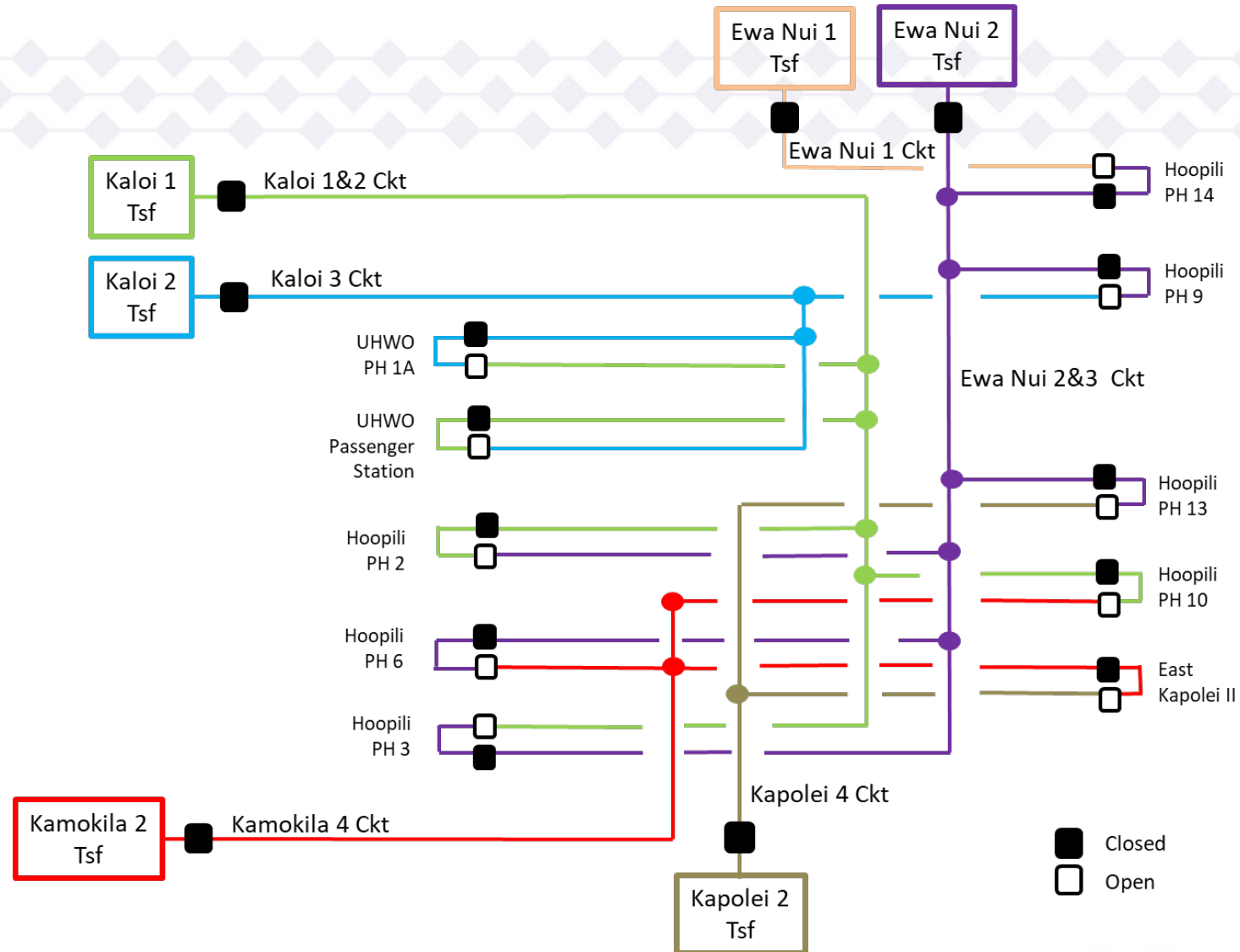

Ho'opili Area Review

◆ Ho'opili Area Review

- ◆ How many Tsfs/Ckts are projected to have planning criteria violations?
- ◆ How many days are projected to have criteria violations?
- ◆ What is the max. overloading (MVA) for each year?
- ◆ What is the max. single day duration overload for each year?
- ◆ What is the max. single day overload (MWh) for each year?

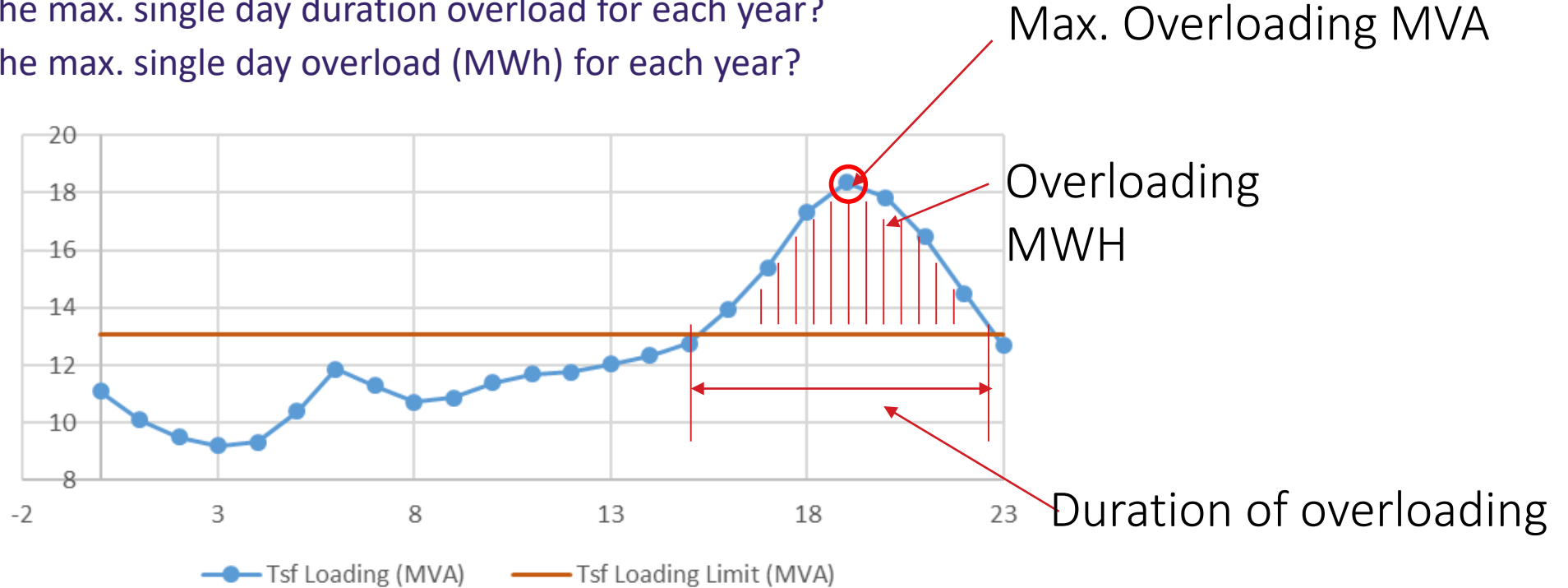

Ho'opili Area Capacity Study

Contingency Conditions

- ◆ Kamokila 2 Tsf
 - ◆ Loss of Ewa Nui 2 Tsf
 - ◆ Loss of Kaloi 1 Tsf
- ◆ Kapolei 2 Tsf
 - ◆ Loss of Kamokila 2 Tsf
 - ◆ Loss of Ewa Nui 2 Tsf
- ◆ Ewa Nui 2 Tsf
 - ◆ Loss of Kaloi 1 Tsf
- ◆ Ewa Nui 1 Tsf
 - ◆ Loss of Ewa Nui 2 Tsf
- ◆ Kaloi 1 Tsf
 - ◆ Loss of Ewa Nui 2 Tsf
 - ◆ Loss of Kaloi 2 Tsf
- ◆ Kaloi 2 Tsf
 - ◆ Loss of Kaloi 1 Tsf
 - ◆ Loss of Ewa Nui 2 Tsf

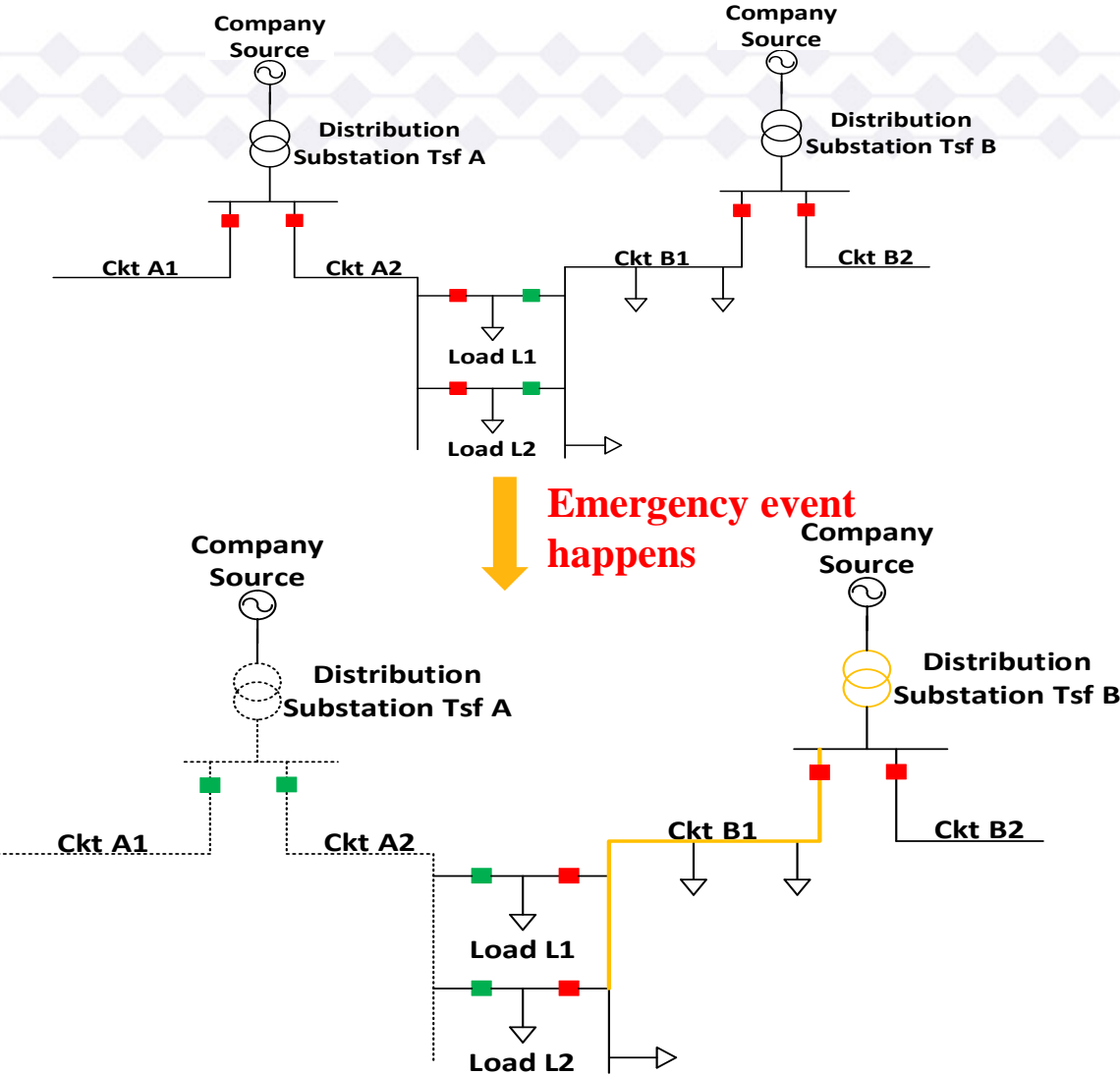

Ho'opili Area Capacity Study

- ◆ Planning criteria violation summary
 - ◆ Ho'opili area review
 - ◆ Transformer/Circuit level overloading review
- ◆ Solution identification
 - ◆ Focused on 5-year plan
 - ◆ Potential NWA opportunities
 - ◆ Wires Solution



Ho'opili Area Review

- ◆ How many Tsfs/Ckts are projected to have planning criteria violations
 - ◆ Normal Condition

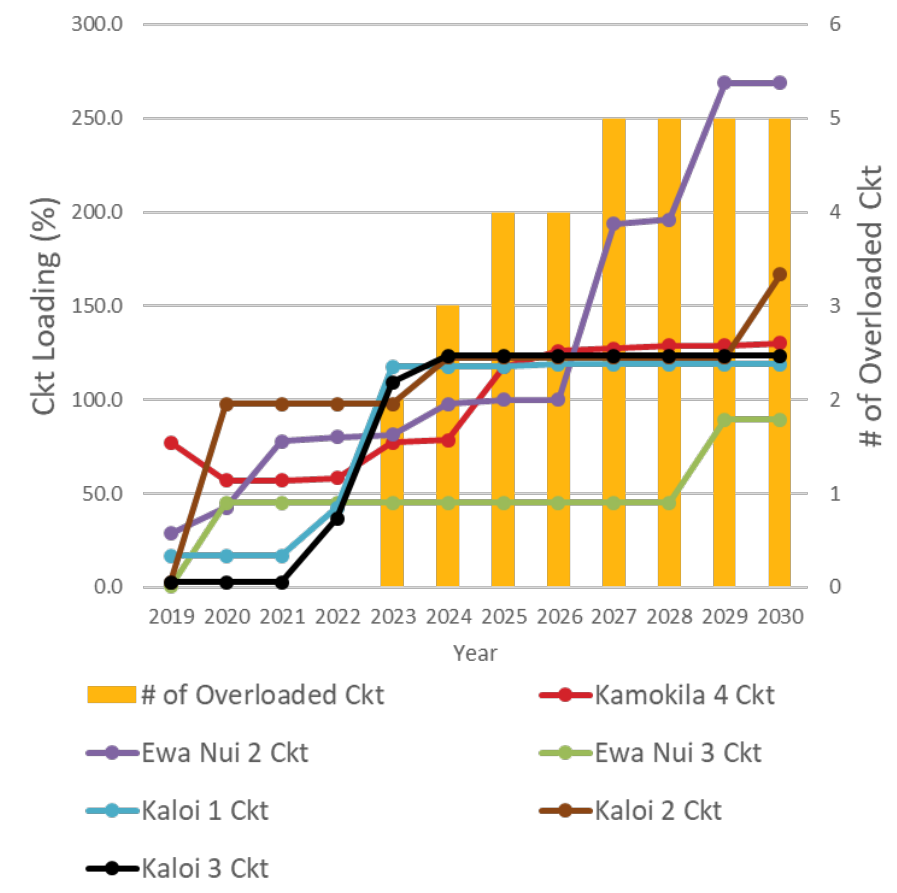
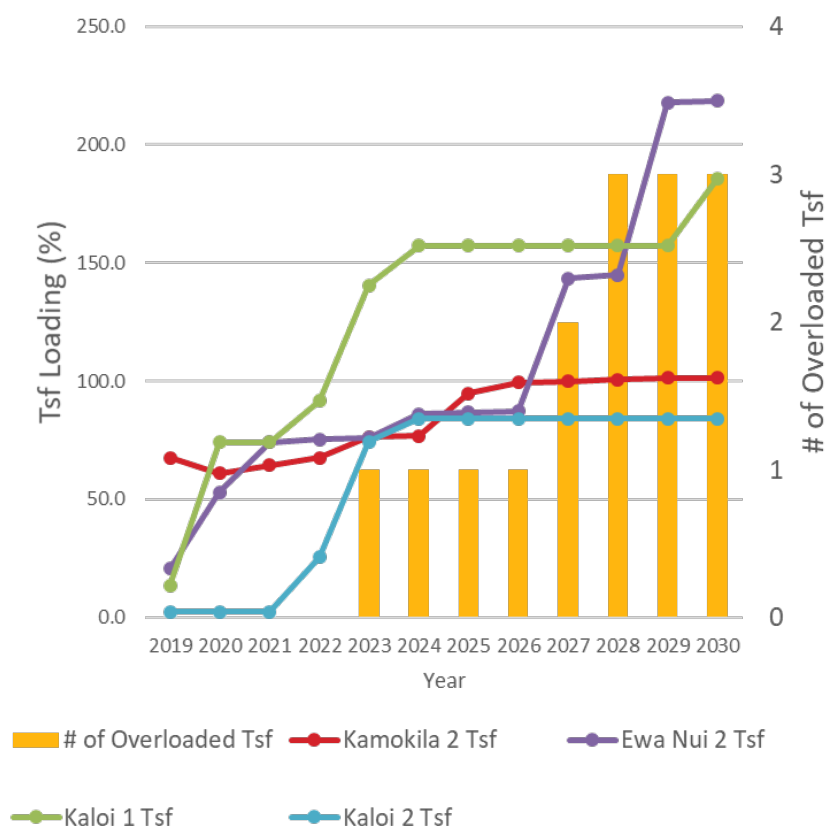

Ho'opili Area Review

- ◆ How many Tsfs/Ckts are projected to have planning criteria violations
 - ◆ Contingency Condition

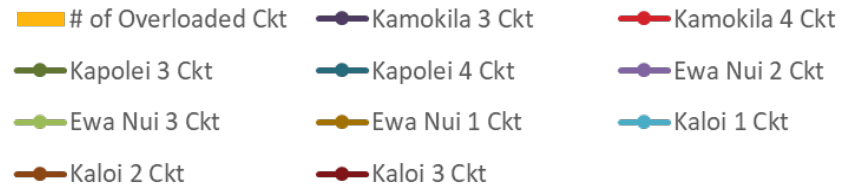
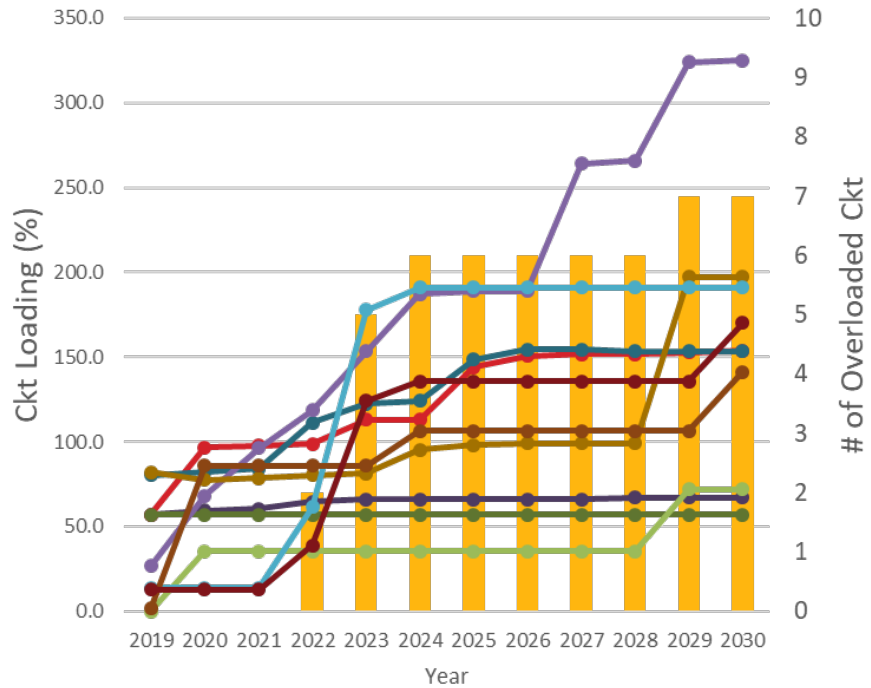
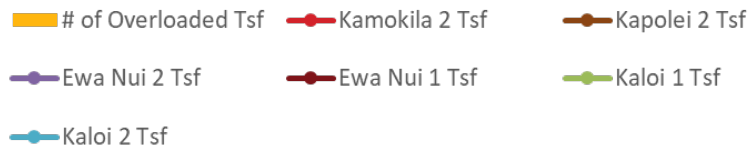
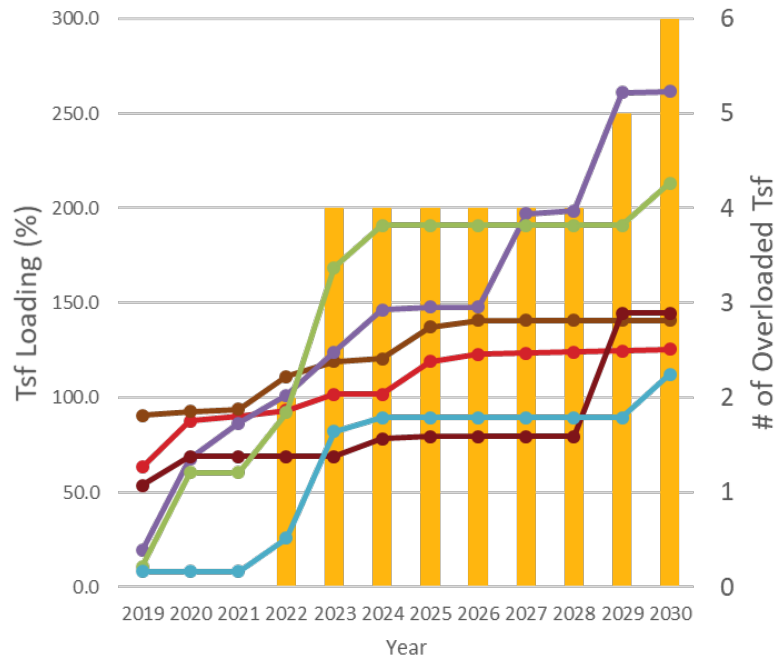

2022 Ho'opili Contingency Overload

Ewa Nui 2 Ckt Loading, Loss of Kaloi 1 Tsf

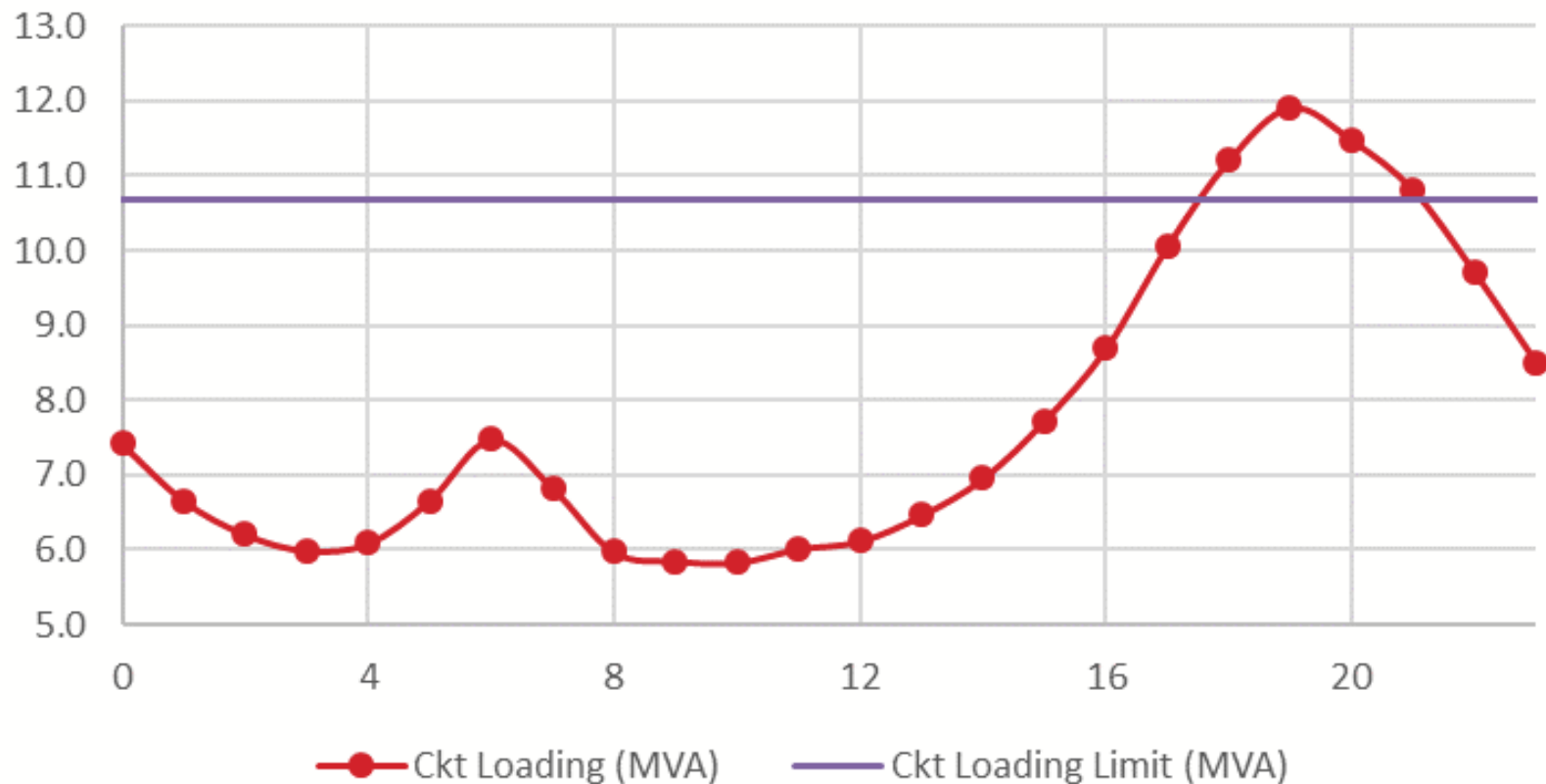

2023 Ho'opili Contingency Overloads

Kamokila 4 Ckt, Loss of Kaloi 1 Tsf

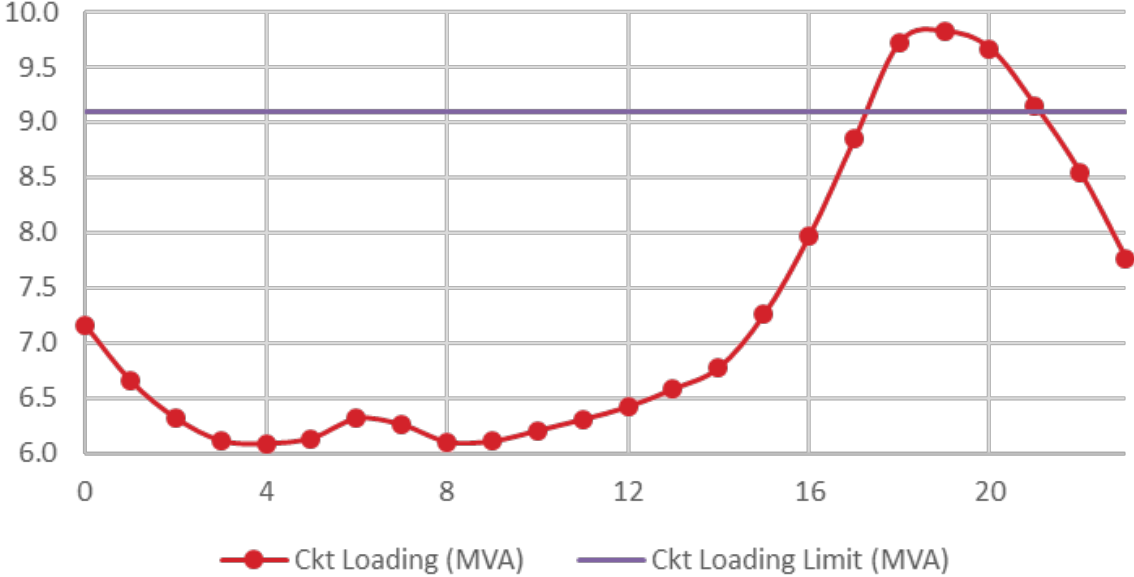

Kapolei 2 Tsf, Loss of Kamokila 2 Tsf

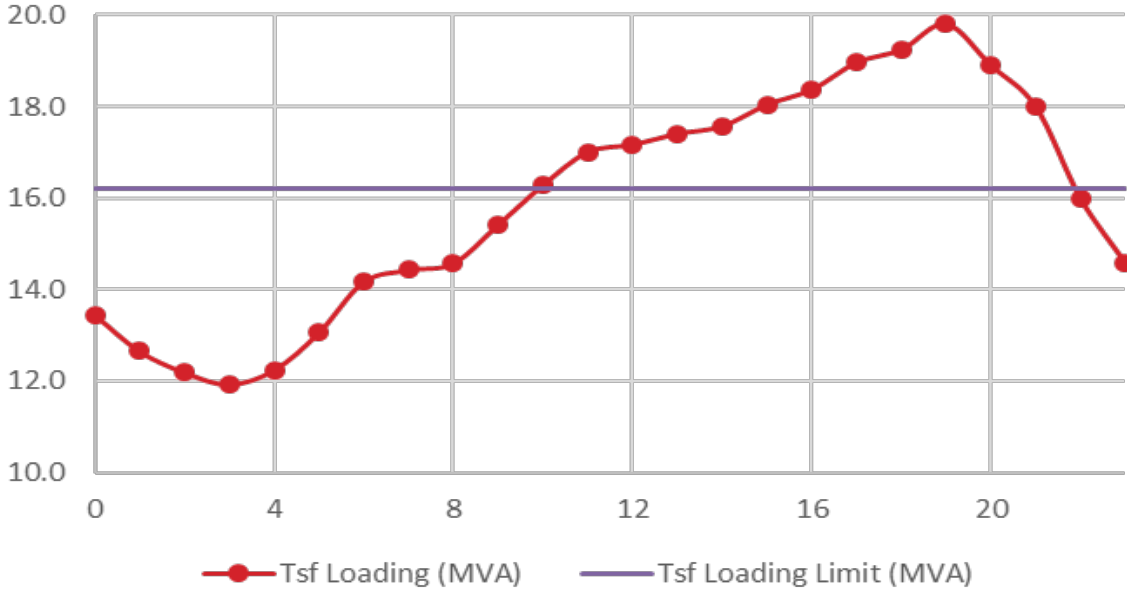

Per forecast, Ho'opili area will have both transformer and circuit overloading from 2022 with critical overloading starting in 2023. Potential service reliability issues need to be addressed.

2023 Ho'opili Contingency Overloads

Ewa Nui 2 Tsf, Loss of Kaloi 1 Tsf

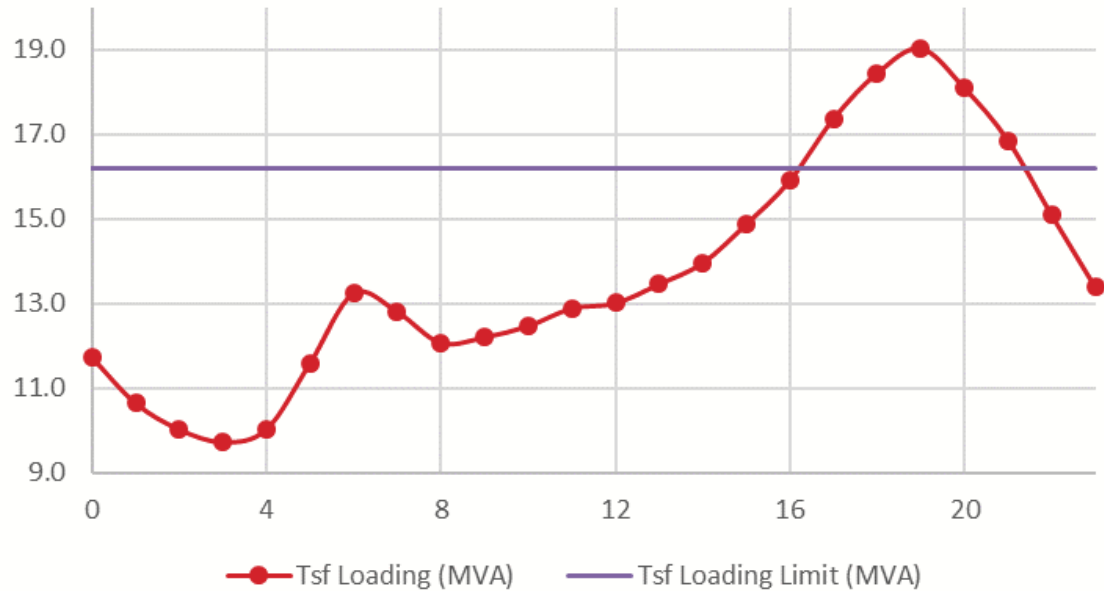

Ewa Nui 2 Ckt, Loss of Kaloi 1 Tsf

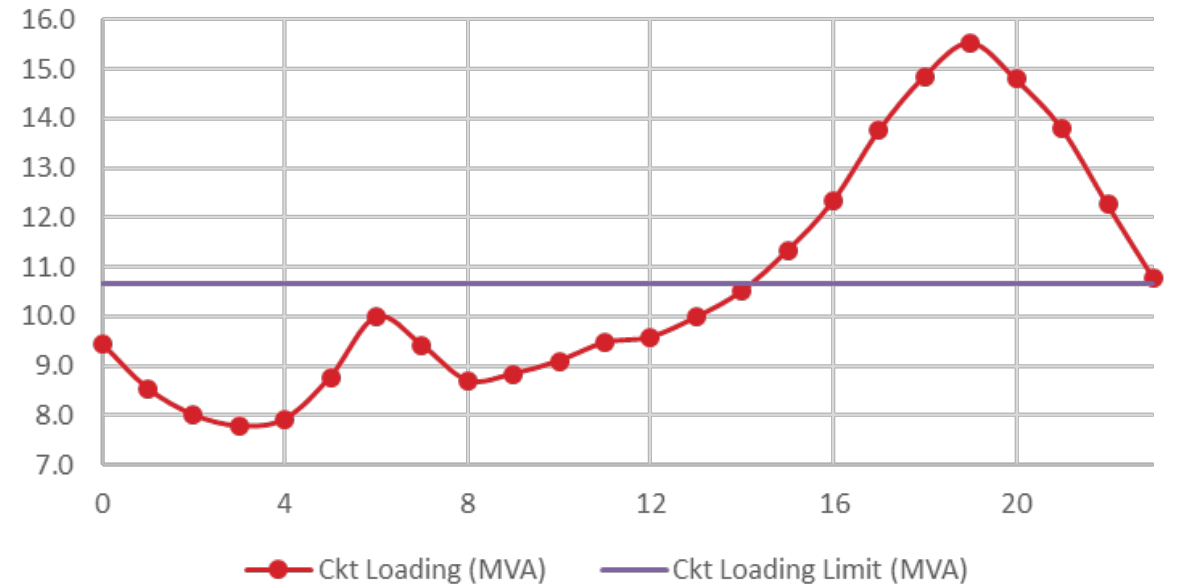

2023 Ho'opili Contingency Overloads

Kaloi 1 Tsf, Loss of Kaloi 2 Tsf

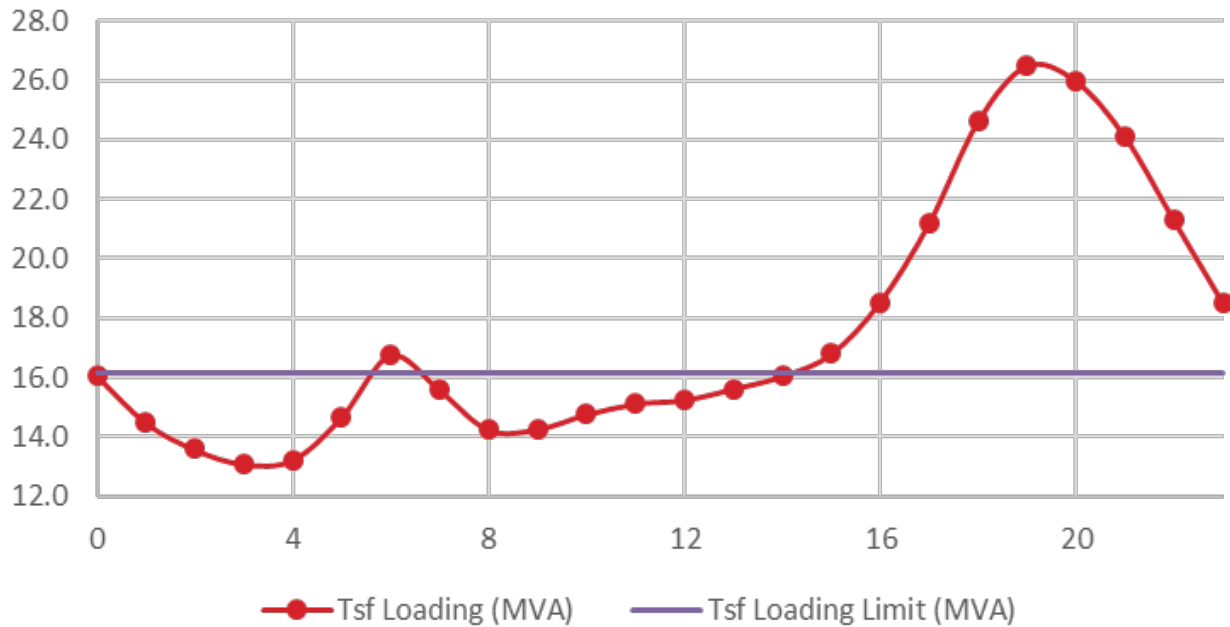

Kaloi 3 Ckt, Loss of Kaloi 1 Tsf

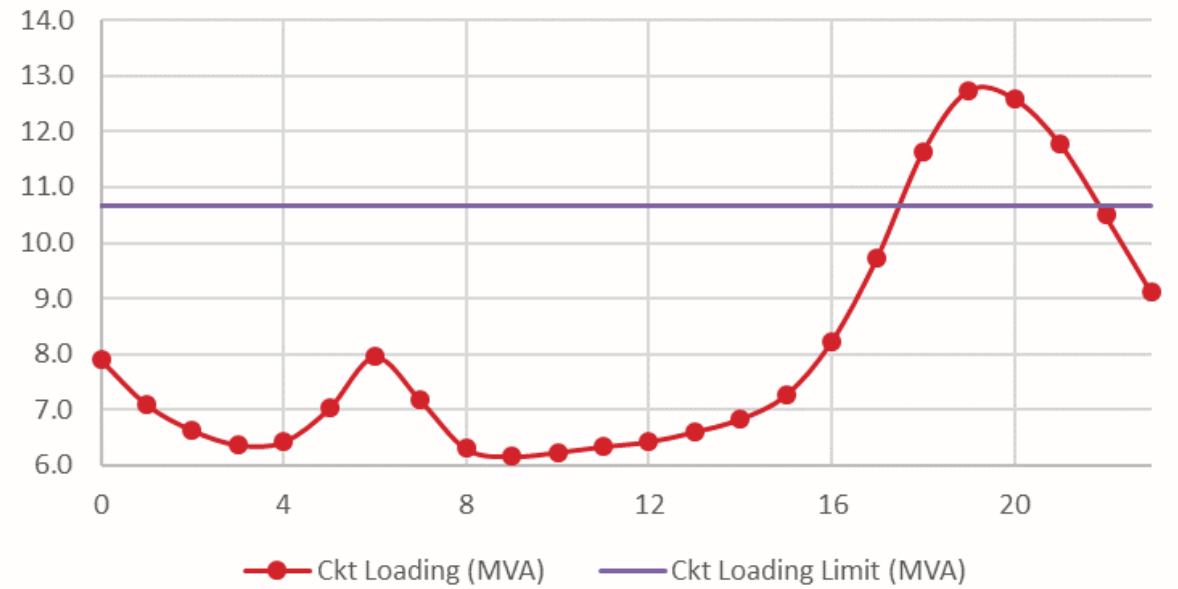

2024 Ho'opili Contingency Overloads

2024 Kaoli 1 Tsf, Loss of Kaloi 2 Tsf

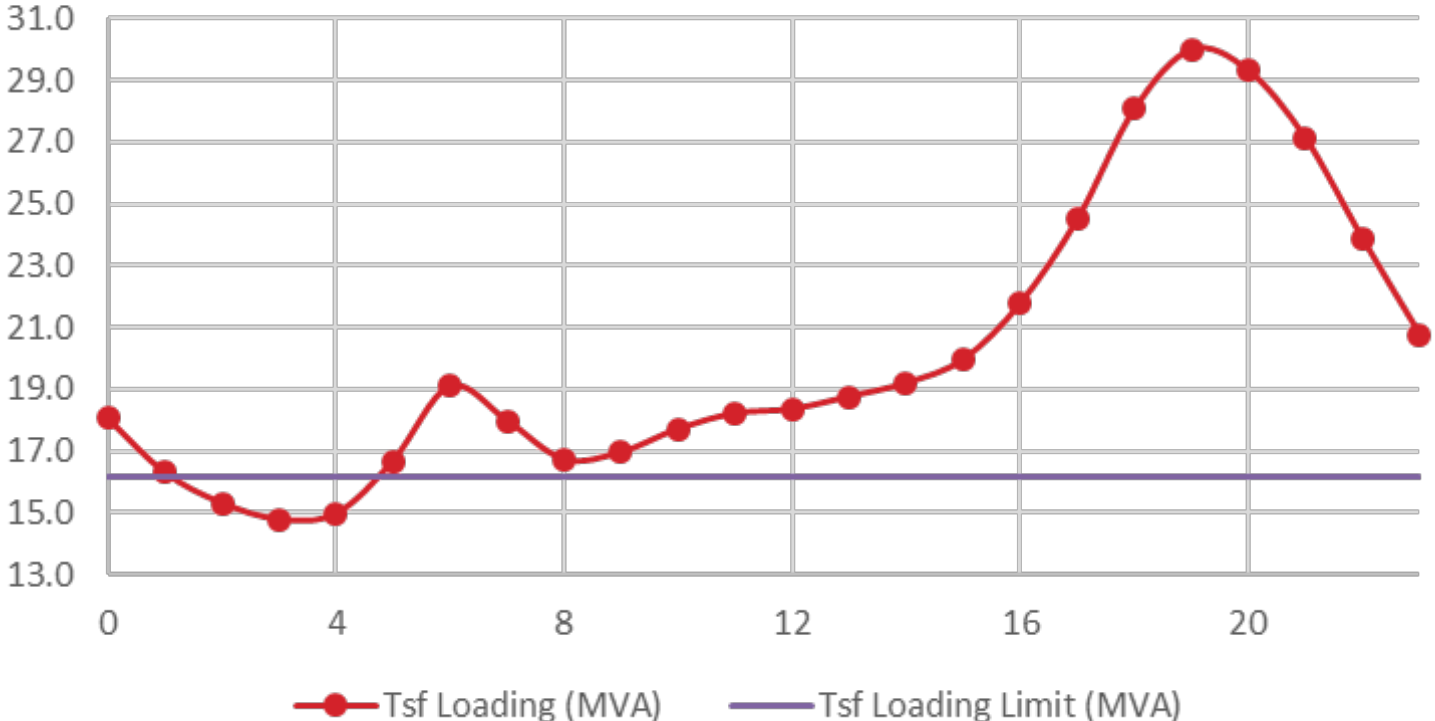

2024 Ho'opili Contingency Overloads

Kaloi 2 Ckt, Loss of Ewa Nui 2 Tsf

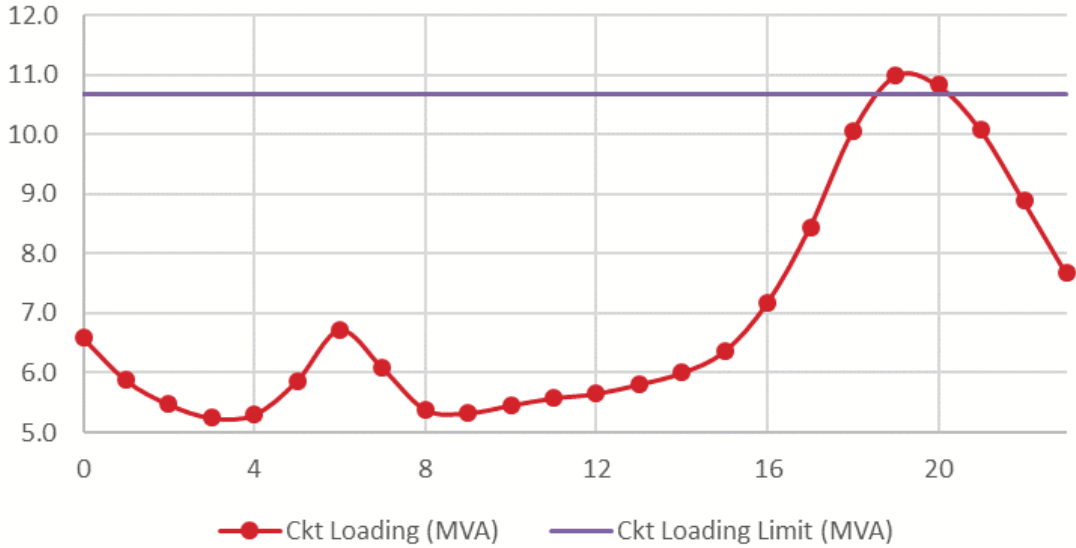

Kaloi 3 Ckt, Loss of Kaloi 1 Tsf

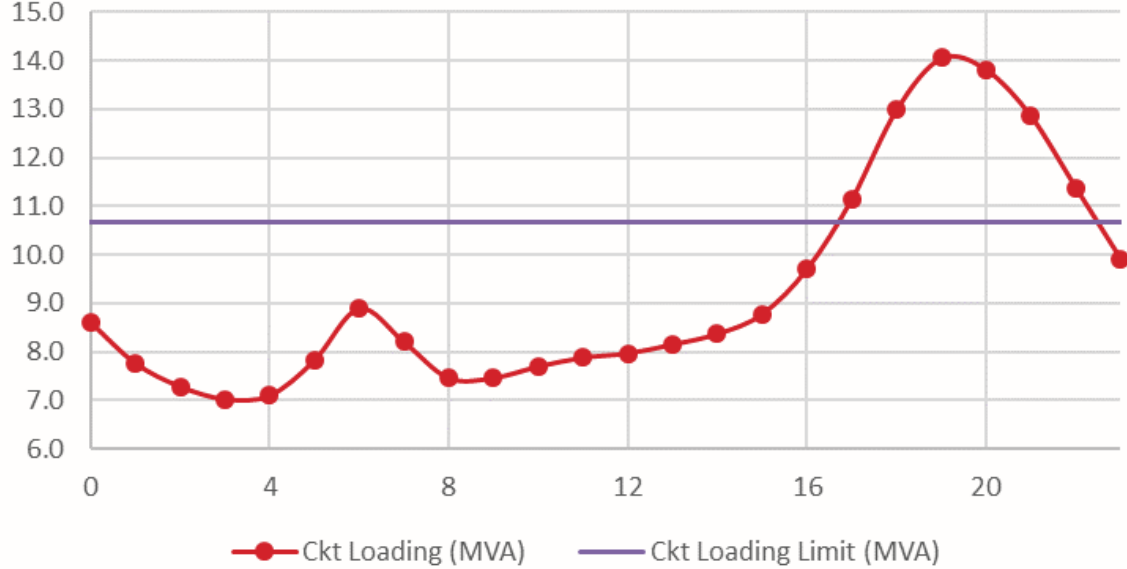

2024 Ho'opili Contingency Overloads

Kapolei 2 Tsf, Loss of Kamokila 2 Tsf

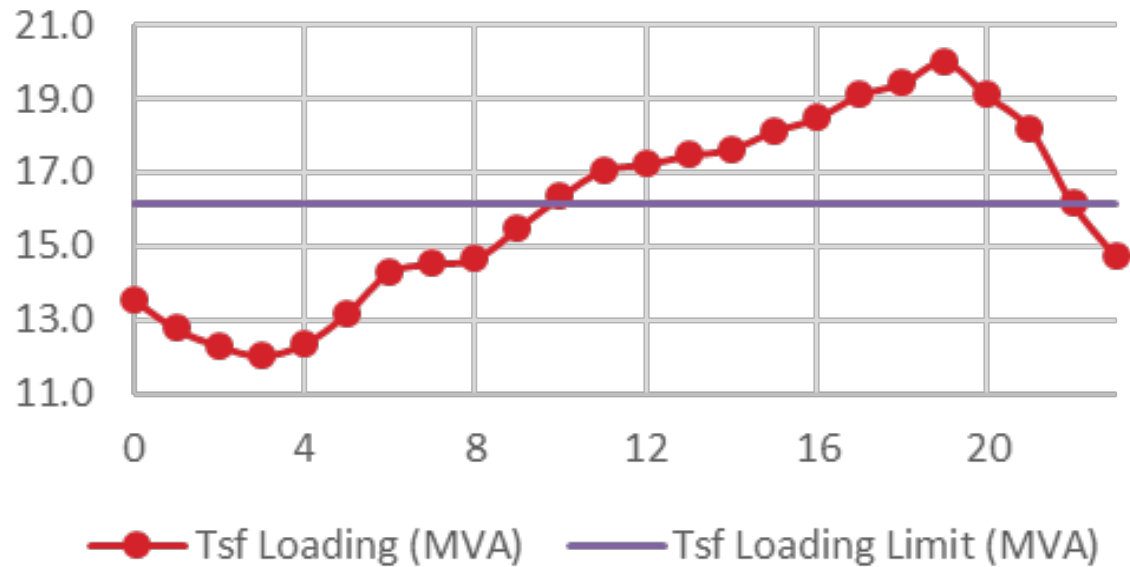

Kamokila 4 Ckt, Loss of Kaloi 1 Tsf

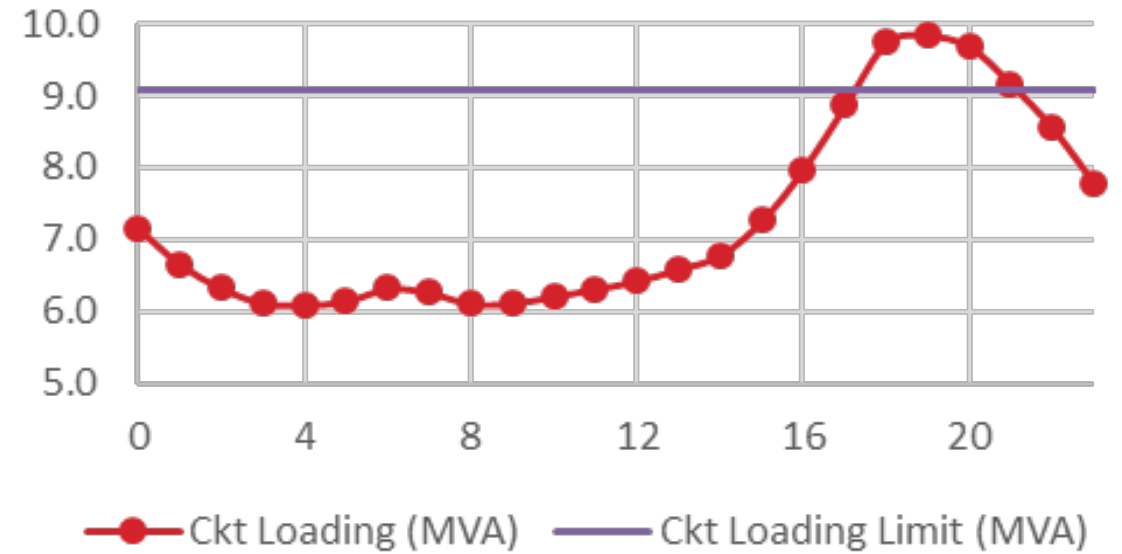

2024 Ho'opili Contingency Overloads

Ewa Nui 2 Ckt, Loss of Kaloi 1 Tsf

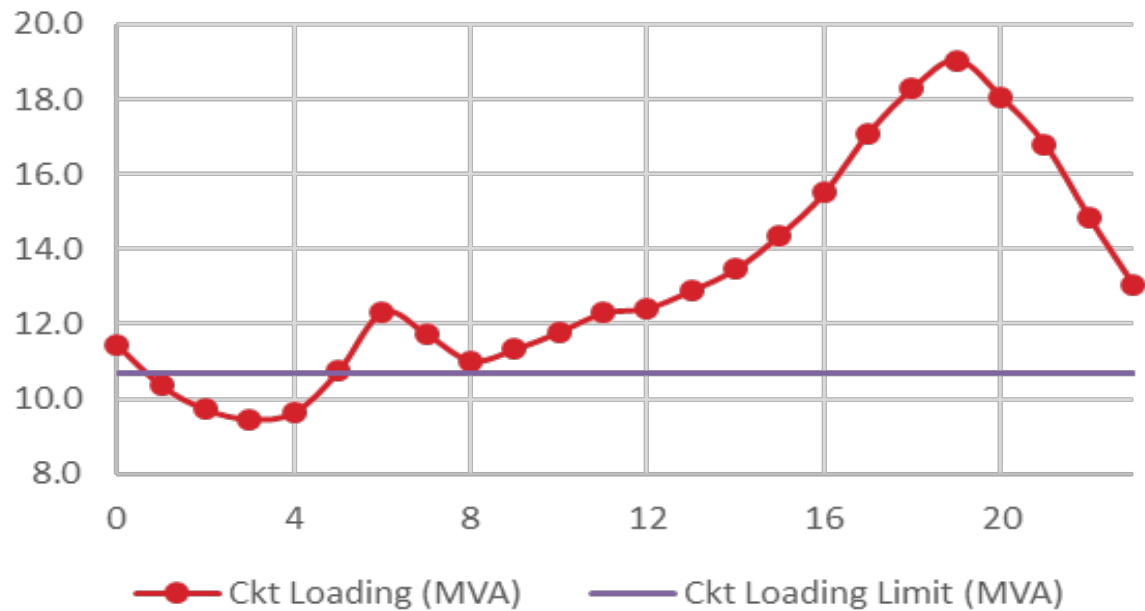

Ewa Nui 2 Tsf, Loss of Kaloi 1 Tsf

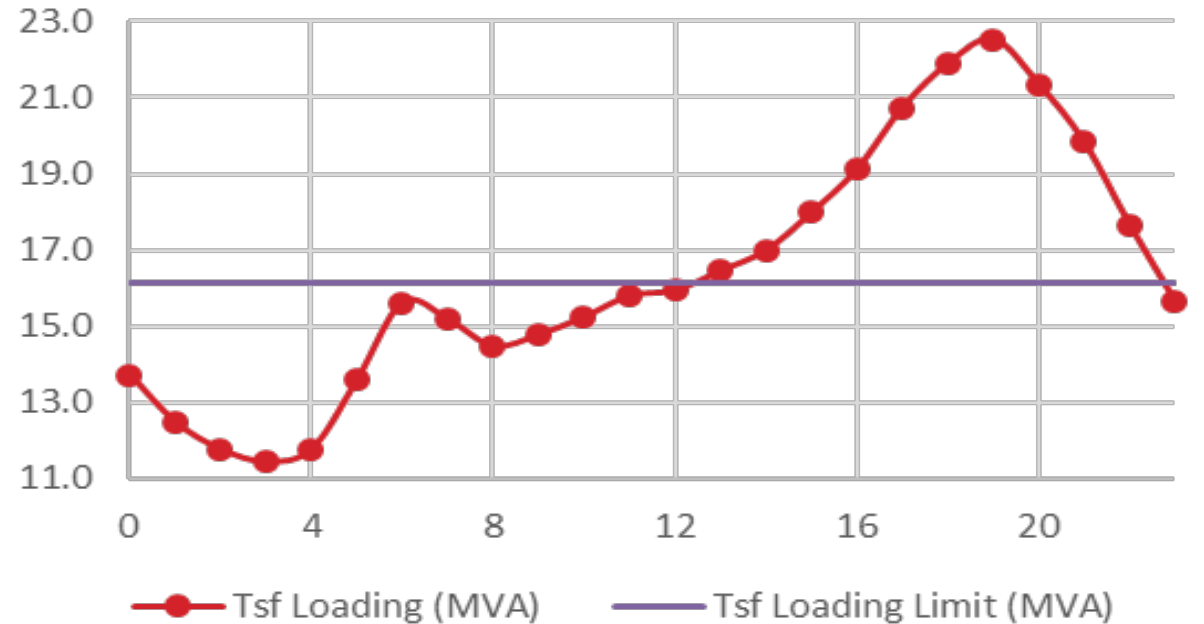

2024 Ho'opili Contingency Overloads

- ◆ How many days are projected to have criteria violations?

Max. # of Days with Overloading Issue
Normal Conditions

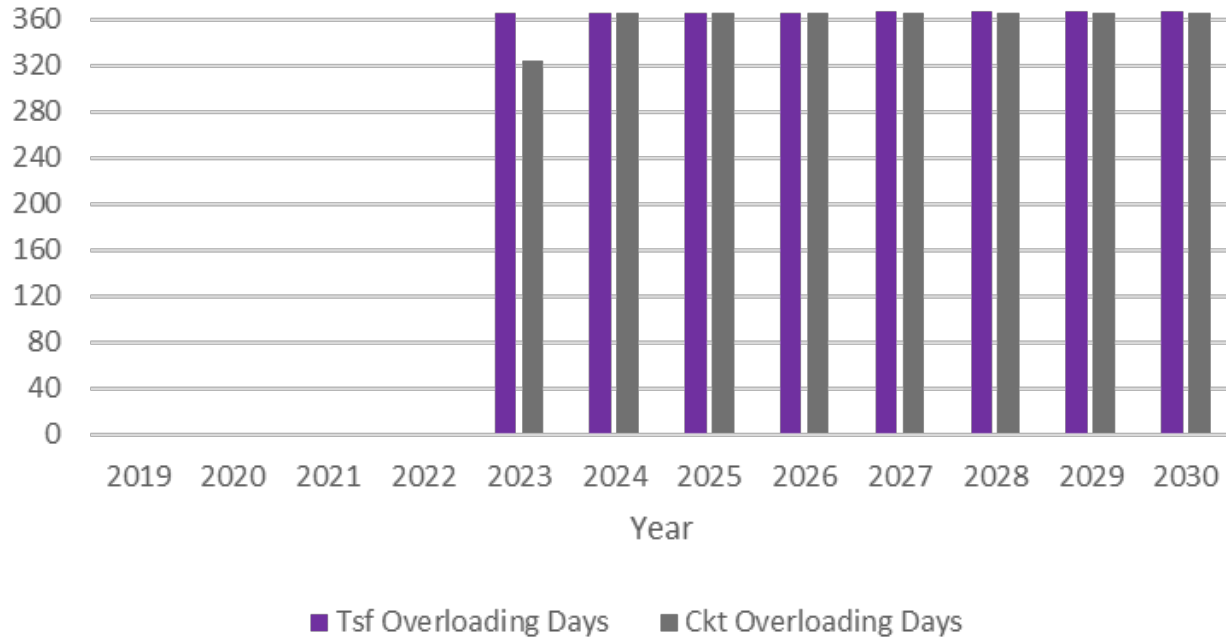

Max. # of Days with Overloading Issue
Contingency Conditions

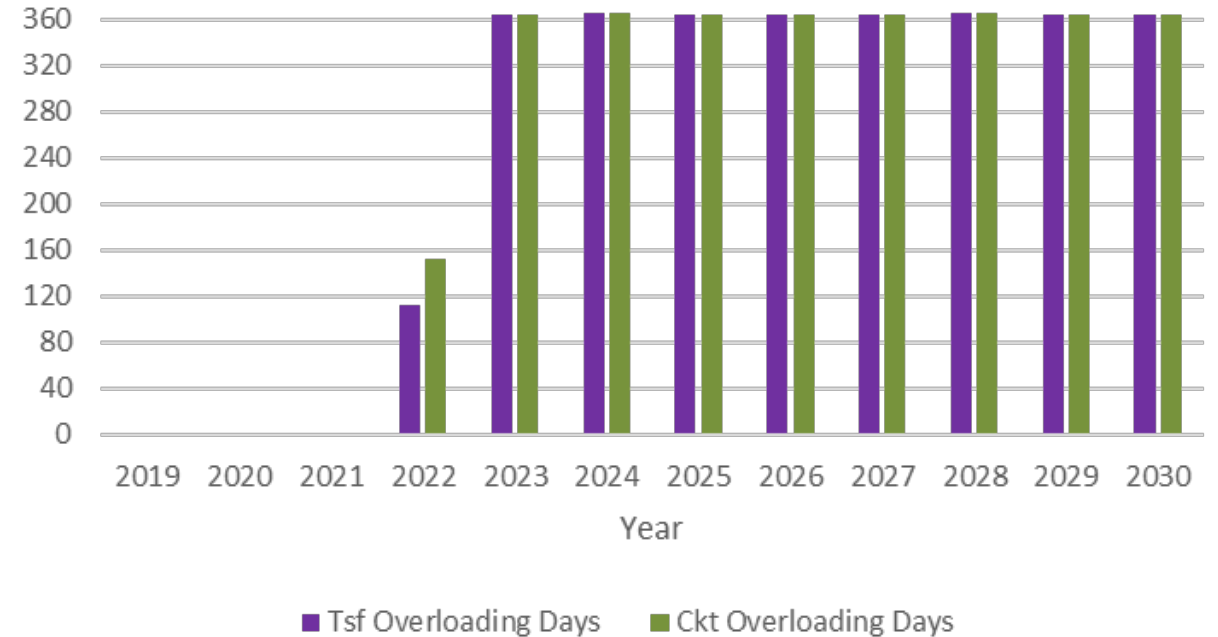

2022 Ho'opili Need

Kapolei 2 Tsf Peak Overload in Contingency Condition, in 2022

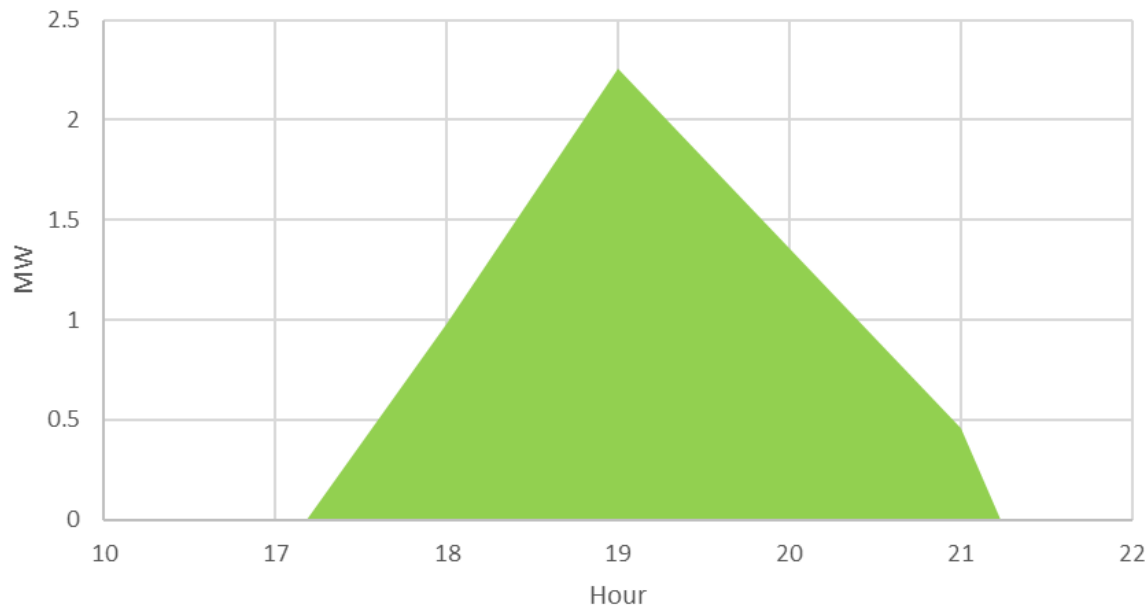

Ewa Nui 2 Circuit Peak Overload in Contingency Condition, in 2022

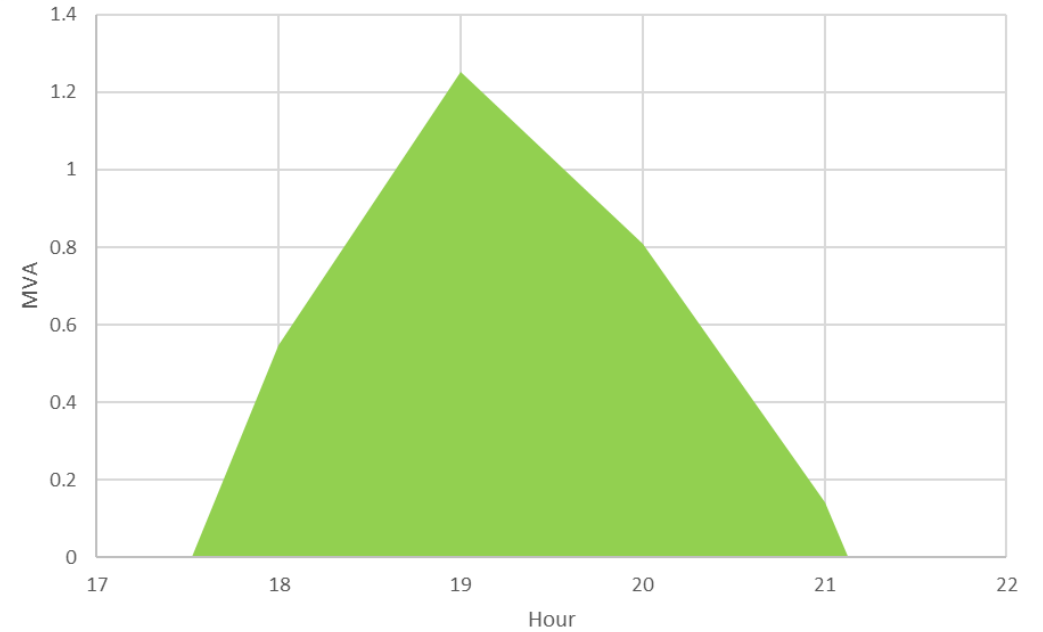

Kapolei 2 being procured under East Kapolei Soft Launch

Need	Capacity (MVA)	Delivery Months	Delivery Hours	Hours Duration	Maximum # of Calls per year
Kapolei 2 Tsf	2.3	Jan – Dec	5PM – 10PM	5	255
Ewa Nui 2 Ckt	1.3	Jun – Oct	5PM – 9PM	3.5	153



2023 Ho'opili Needs

Kapolei 2 Tsf Peak Overload in Contingency Condition, in 2023

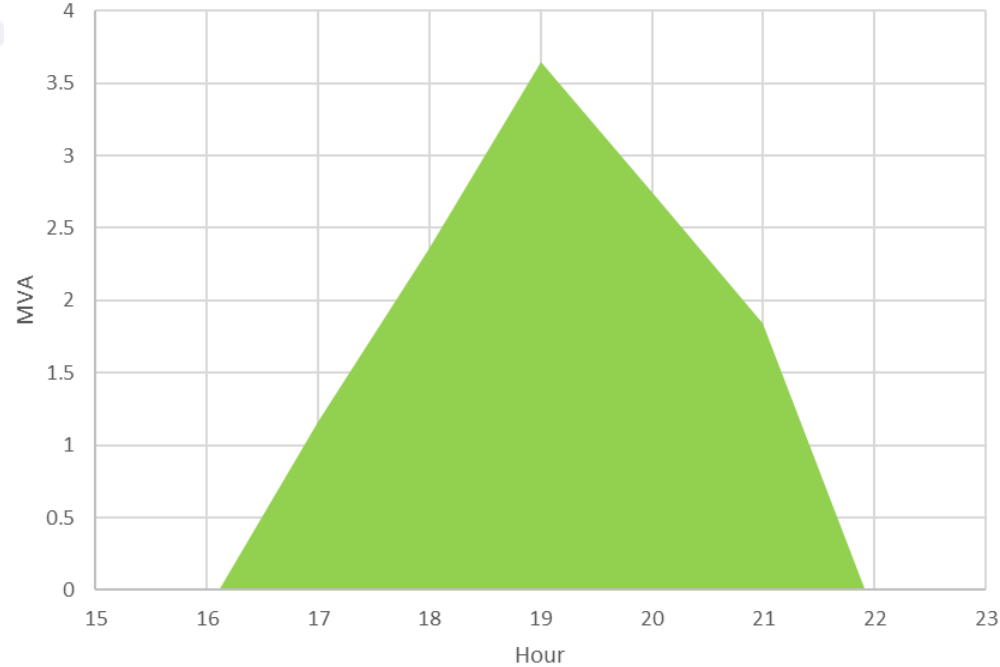

Ewa Nui 2 Circuit Peak Overload in Contingency Condition, in 2023

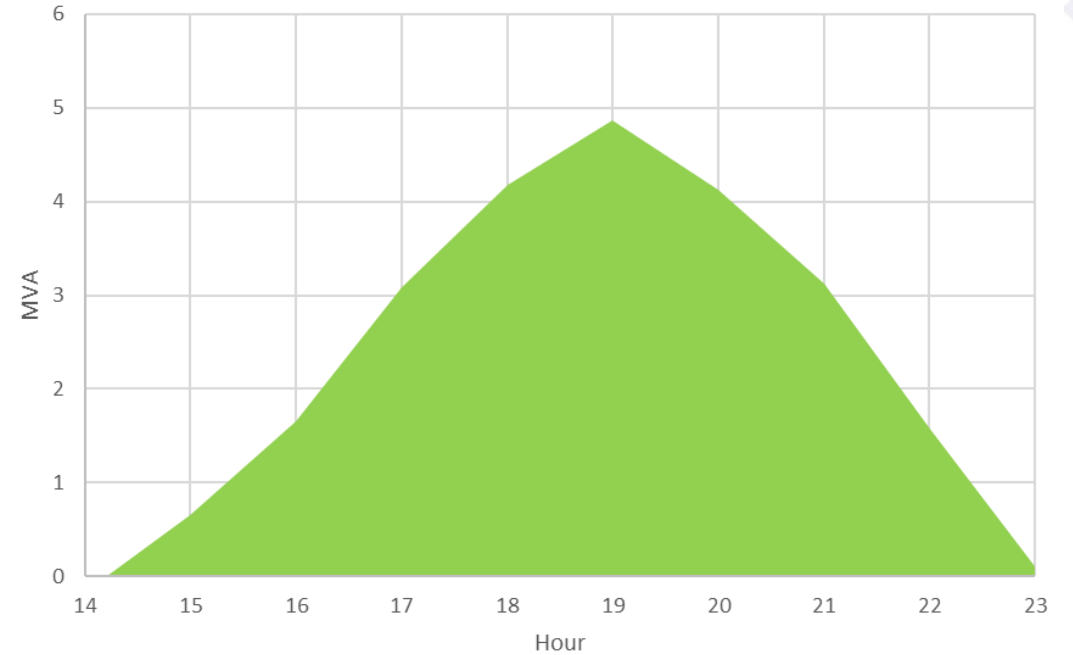

Need	Capacity (MVA)	Delivery Months	Delivery Hours	Hours Duration	Maximum # of Calls per year
Kapolei 2 Tsf	3.6	Jan – Dec	4PM – 10PM	6	365
Ewa Nui 2 Ckt	4.8	Jan – Dec	2PM – 11PM	9	365



2023 Ho'opili Needs

Kaloi 1 Tsf Peak Overload in Contingency Condition, in 2023

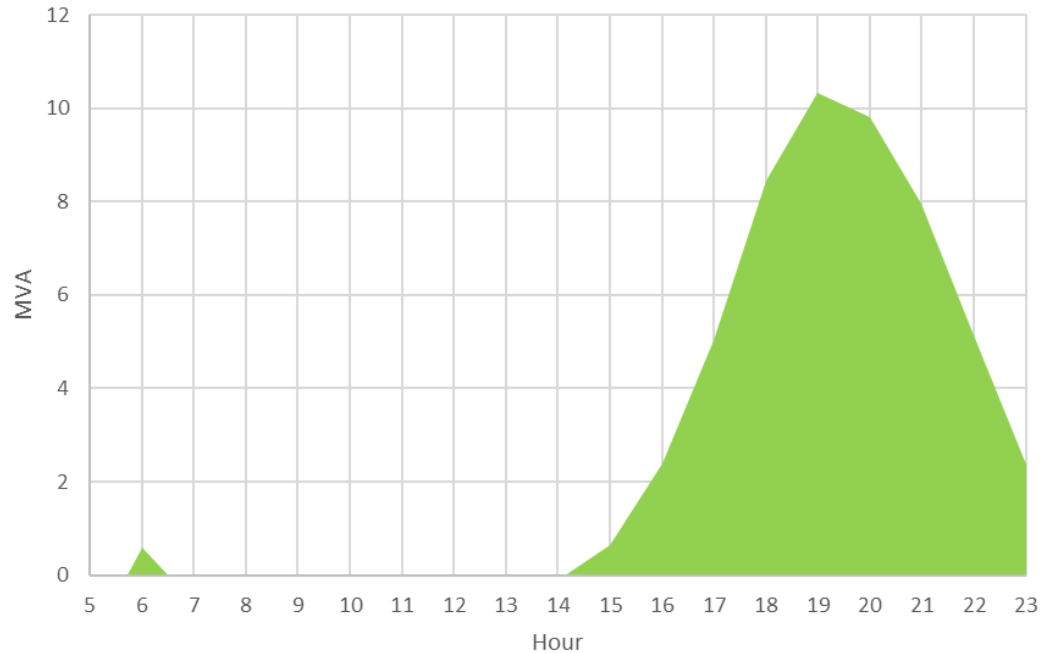

Kaloi 3 Circuit Peak Overload in Contingency Condition, in 2023

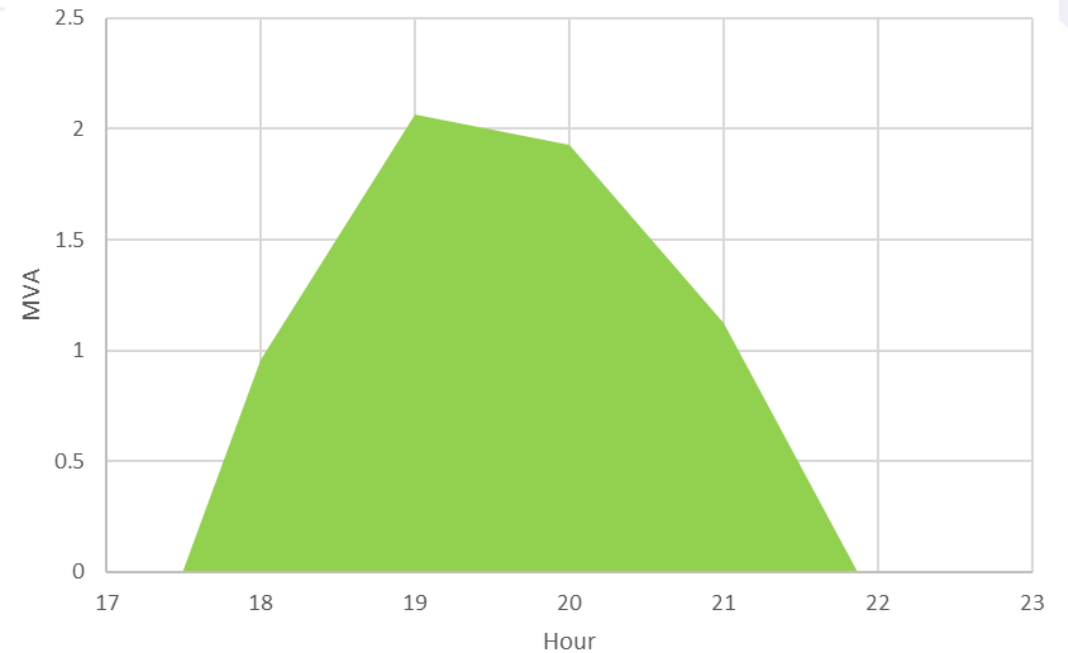

Need	Capacity (MVA)	Delivery Months	Delivery Hours	Hours Duration	Maximum # of Calls per year
Kaloi 1 Tsf	10.3	Jan – Dec	2PM – 12AM	10	365
Kaloi 3 Ckt	2.1	Jan – Dec	5PM – 10PM	5	365



2023 Ho'opili Needs

Kamokila 4 Circuit Peak Overload in Contingency Condition, in 2023

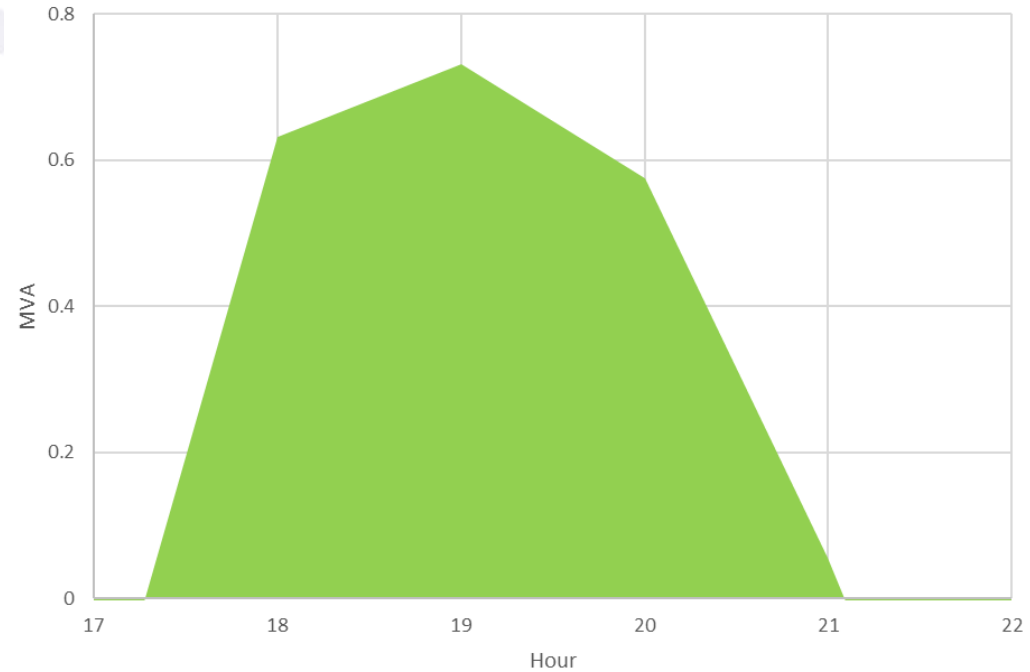

Need	Capacity (MVA)	Delivery Months	Delivery Hours	Hours Duration	Maximum # of Calls per year
Kamokila 4 Ckt	0.7	Jun – Oct	5PM – 9PM	4	145

No additional load added from Ho'opili to Kamokila 4 Ckt in 2024.



2024 Ho'opili Needs

Kapolei 2 Tsf Peak Overload in Contingency Condition, in 2024

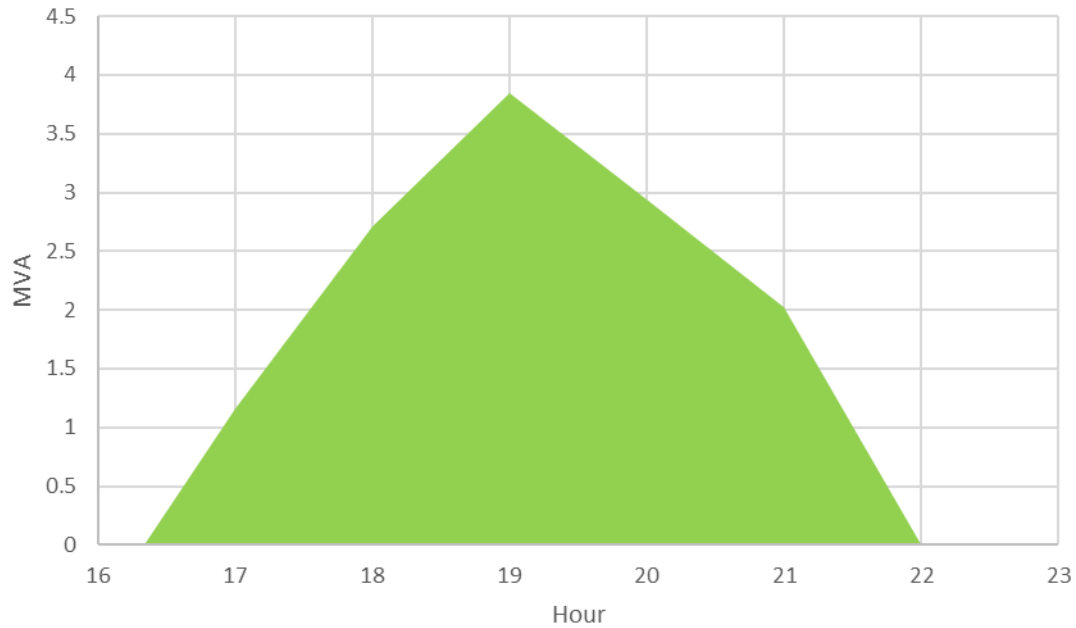

Ewa Nui 2 Circuit Peak Overload in Contingency Condition, in 2024

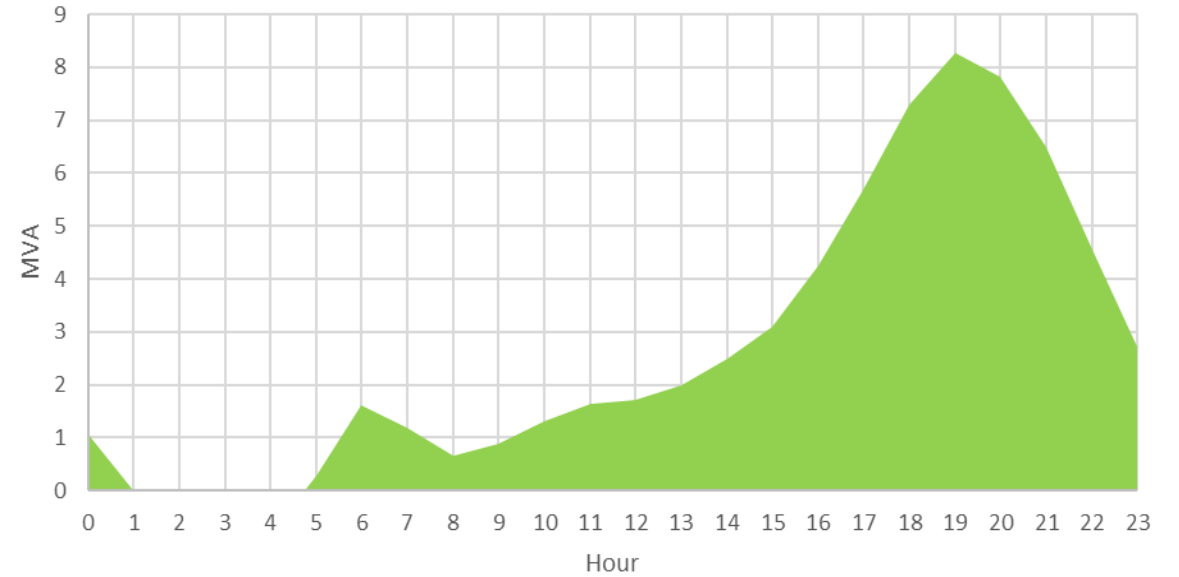

Need	Capacity (MVA)	Delivery Months	Delivery Hours	Hours Duration	Maximum # of Calls per year
Kapolei 2 Tsf	3.9	Jan – Dec	4PM – 10PM	6	366
Ewa Nui 2 Ckt	8.4	Jan – Dec	5AM – 12AM	19	366



2024 Ho'opili Needs

Kaloi 1 Tsf Peak Overload in Contingency Condition, in 2024

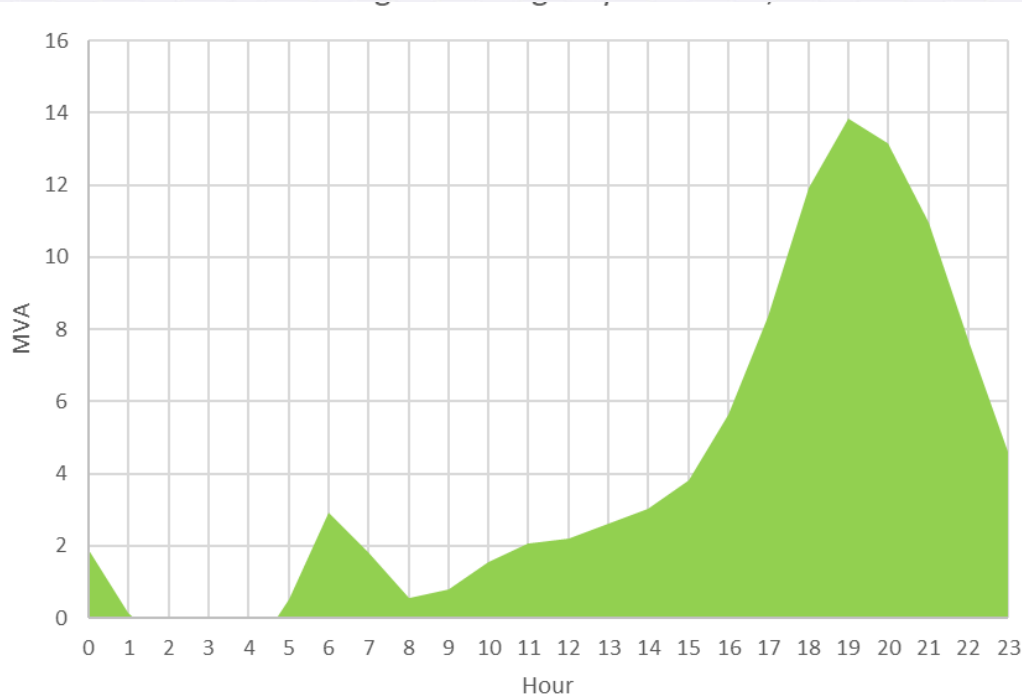

Kaloi 3 Circuit Peak Overload in Contingency Condition, in 2024

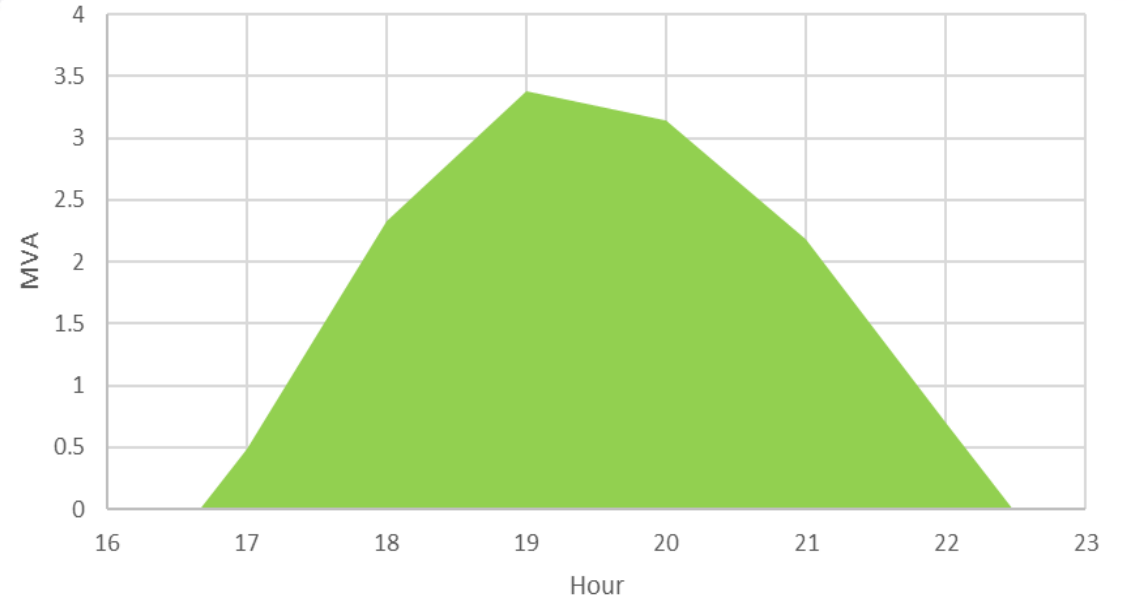

Need	Capacity (MVA)	Delivery Months	Delivery Hours	Hours Duration	Maximum # of Calls per year
Kaloi 1 Tsf	13.8	Jan – Dec	5AM – 1AM	19	366
Kaloi 3 Ckt	3.4	Jan – Dec	4PM – 11PM	7	366



Ho'opili Area Review – Solution Options

- ◆ Over the next 5 years (to 2025) two 10 MVA substation transformers will be needed
- ◆ To defer traditional investments, need:
- ◆ 2022: 1 circuit NWA + 1 NWA for E. Kapolei
- ◆ 2023: 5 circuit/tsf NWA

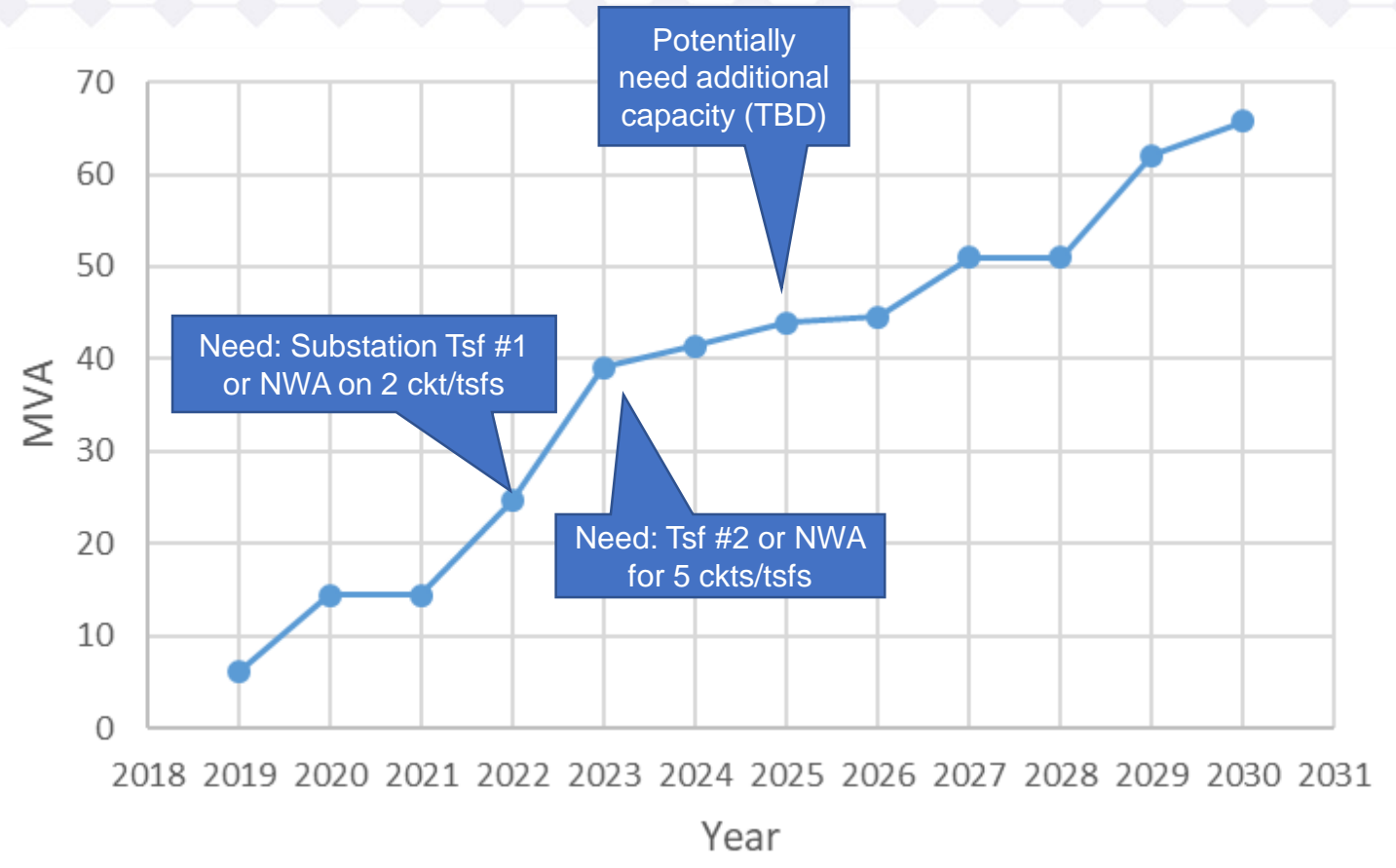

Ho‘opili Phase 1 Avoided Cost

Deferral value to install substation with single 10 MVA transformer unit

	Estimated Cumulative Capital Deferral Value ¹ (\$)	Estimated Capacity ² (MW)
1-Year Deferral	\$ 809,000	2.1
2-Year Deferral	\$ 1,558,000	9.8
3-Year Deferral	\$ 2,251,000	13
4-Year Deferral	\$ 2,894,000	13
5-Year Deferral	\$ 3,490,000	13

PRELIMINARY

¹Accumulated NPV of annual revenue requirement for 1 transformer (~ \$10M total cost)

²Estimated capacity based on peak N-1 overload



Companies' Ho'opili NWA Proposal

- ◆ Initial substation investment with one 10 MVA transformer unit to address base load need
 - ◆ In lieu of initially installing 2 transformer units
- ◆ Proposed NWA sourcing in 2020 to defer 2nd transformer unit in 2023/2024
- ◆ Proposed 2nd NWA to defer potential 3rd transformer unit in 2025-2027 timeframe

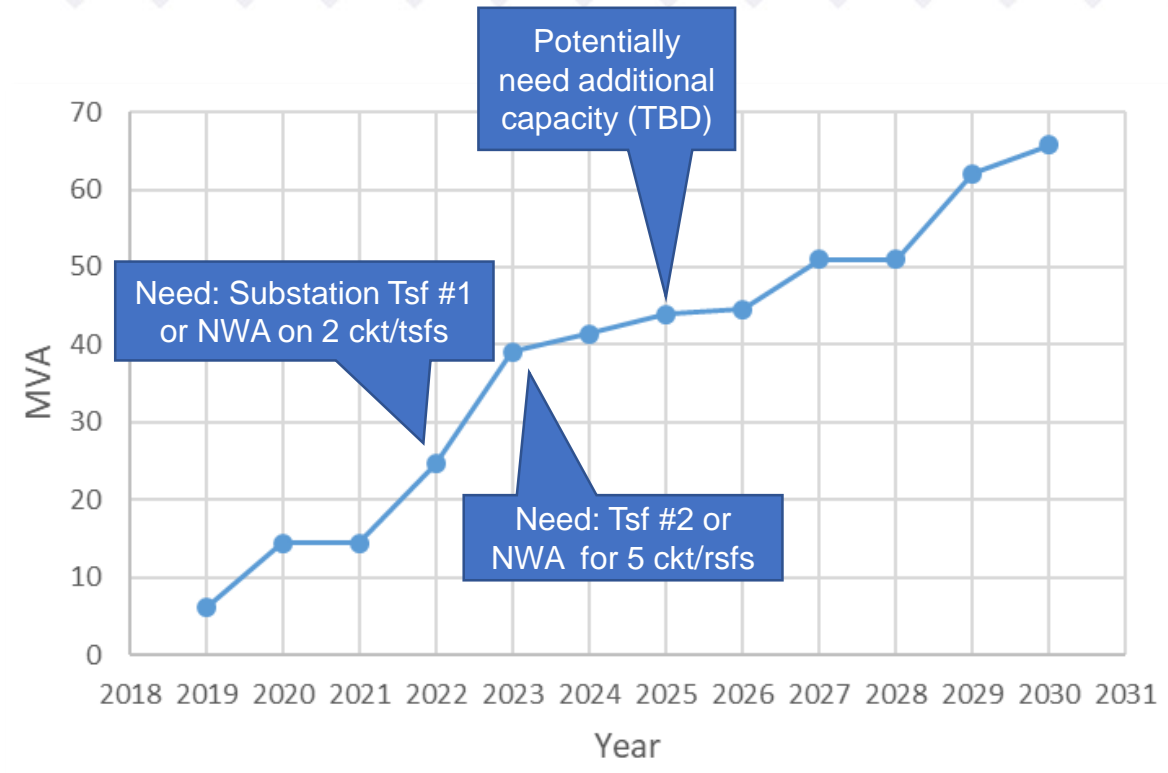



East Kapolei Area Capacity Study

- ◆ Driven by future East Kapolei Subdivision and portion of Ho‘opili Subdivision developments
- ◆ Address system needs to accommodate new loads



East Kapolei Customer Composition

Kamokila 4 Ckt

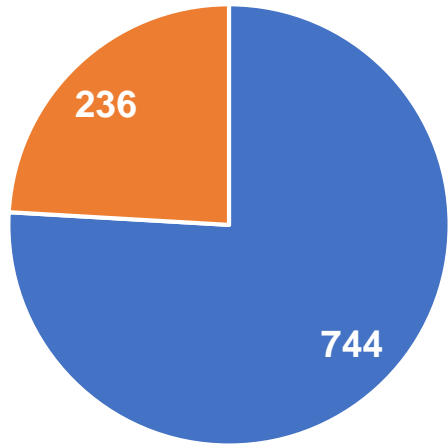

■ Residential ■ Commercial

Kapolei 4 Ckt

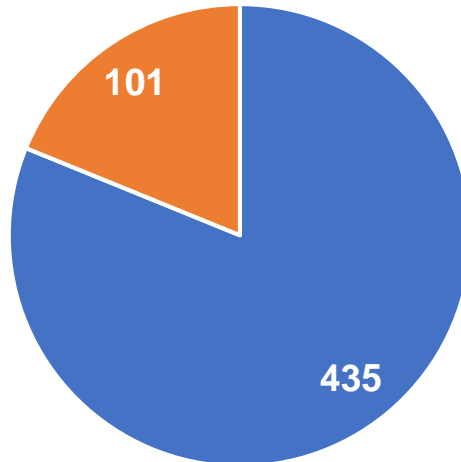

■ Residential ■ Commercial

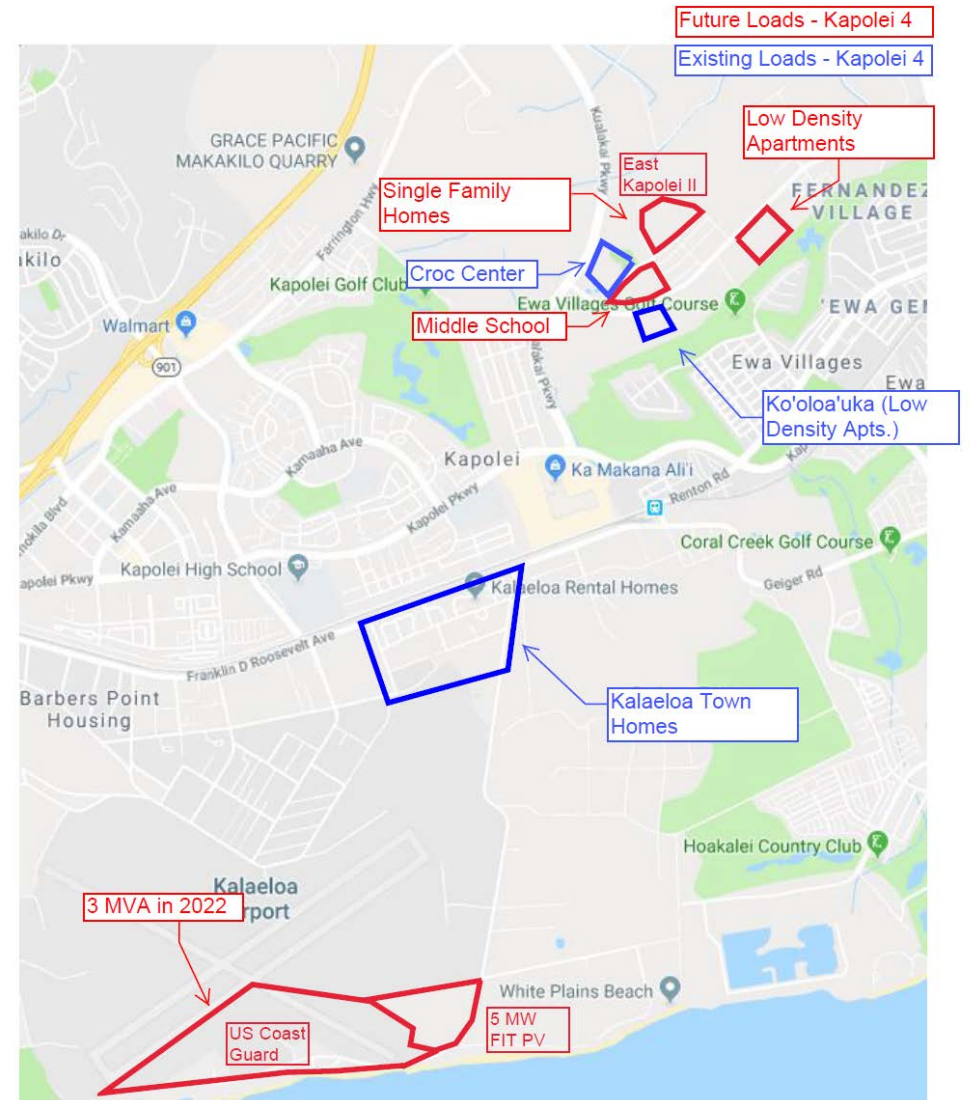

East Kapolei Area Capacity Study

- ◆ Forecasted planning criteria violation occurs from 2022 on Kapolei 2 Tsf and Kapolei 4 Ckt.
- ◆ NWA solution is required on Kapolei 4 circuit to address the loading violations of both Kapolei 2 Tsf and Kapolei 4 Ckt.

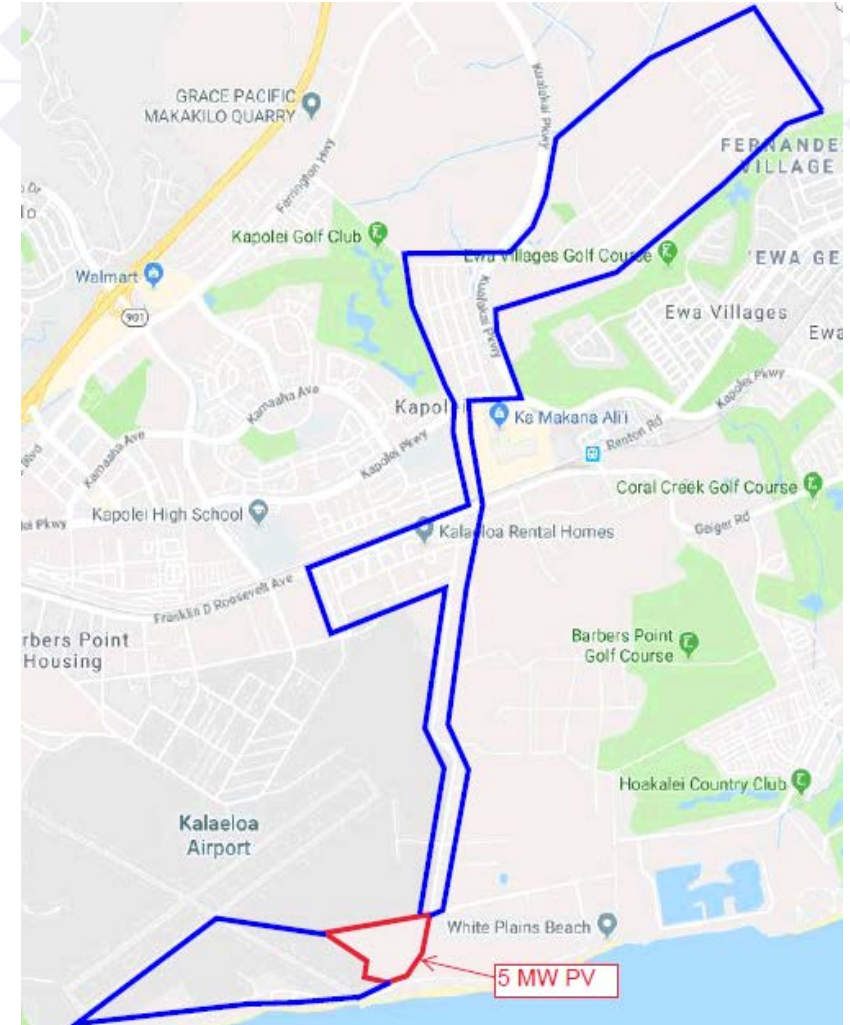

East Kapolei Area Capacity Study

◆ Distribution transformers and circuits involved in the study

Contingency Conditions

- Kamokila 2 Tsf / Kamokila 4 Ckt
 - Loss of Kapolei 2 Tsf
 - Loss of Kapolei 4 Ckt
- Kapolei 2 Tsf / Kapolei 4 Ckt
 - Loss of Kamokila 2 Tsf
 - Loss of Kamokila 4 Ckt

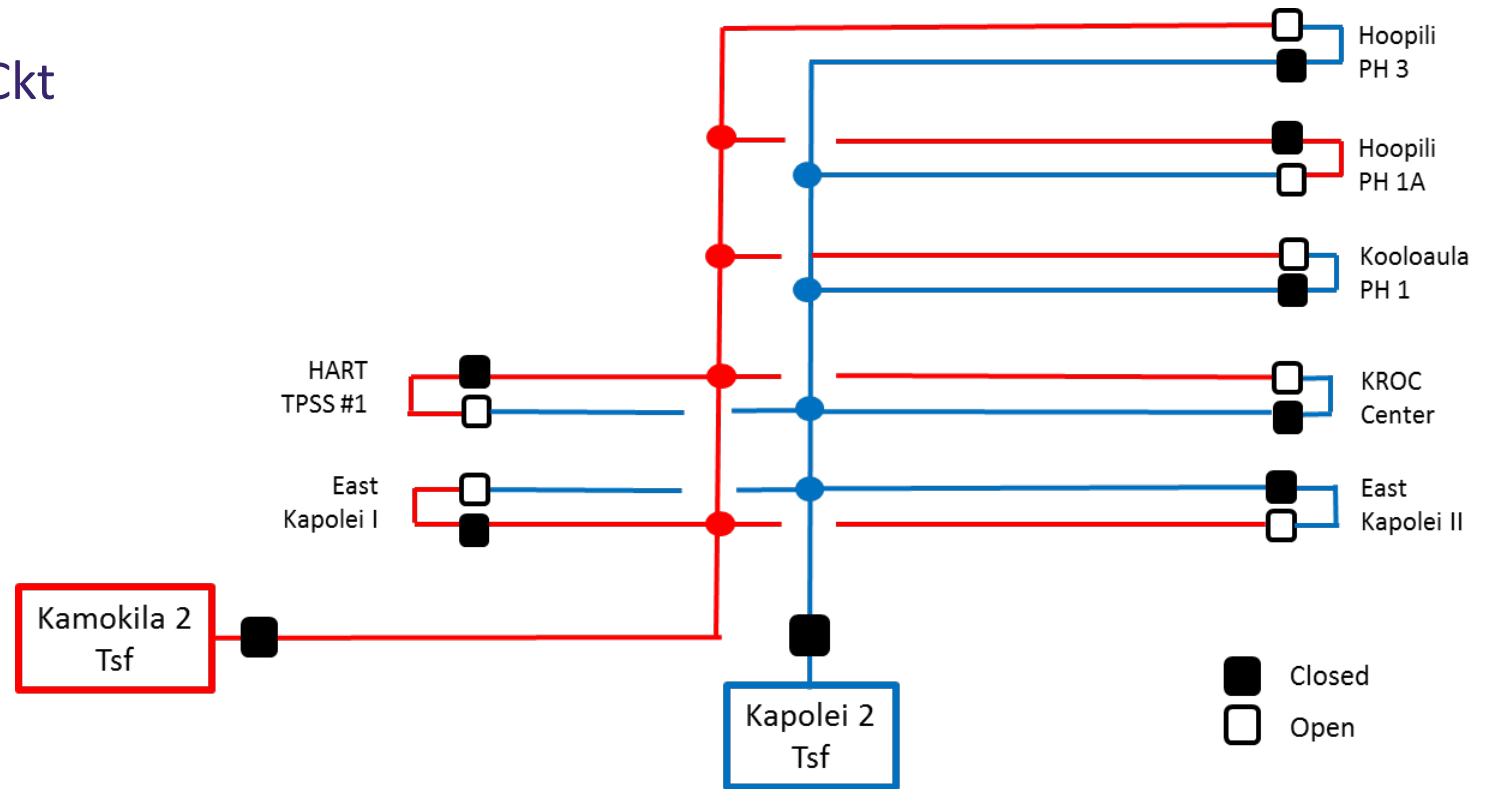

East Kapolei Area Capacity Study

- ◆ Load Growth Description
 - ◆ Kapolei 2 Tsf annual peak load growth summary from 2019 to 2025 (with contingency)

2019-2025 Annual Peak Load Growth

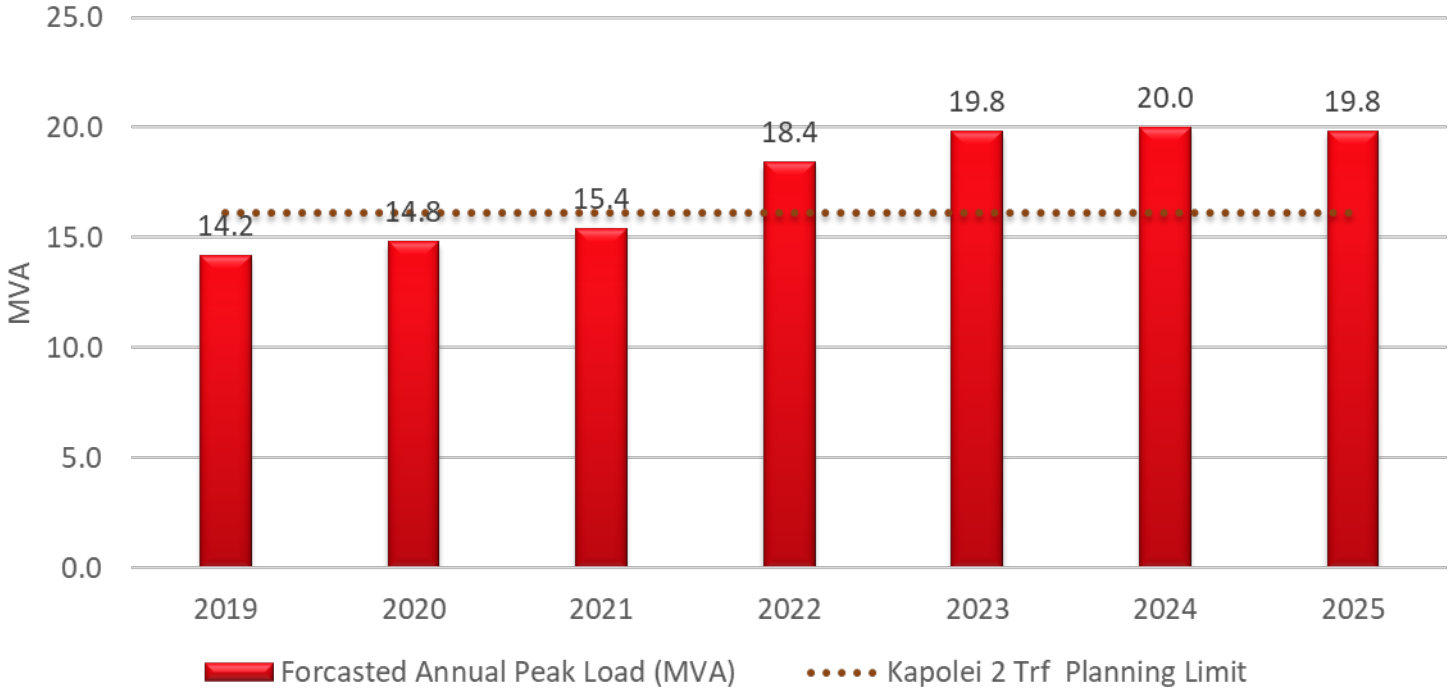

2022 East Kapolei Contingency Overload

Kapolei 2 Tsf, Loss of Kamokila 2 Tsf

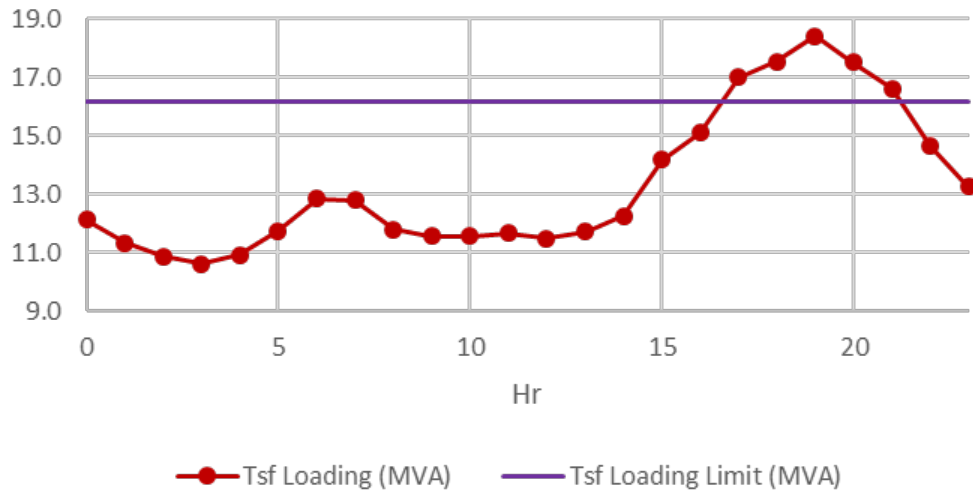

Kapolei 4 Ckt, Loss of Kamokila 2 Tsf

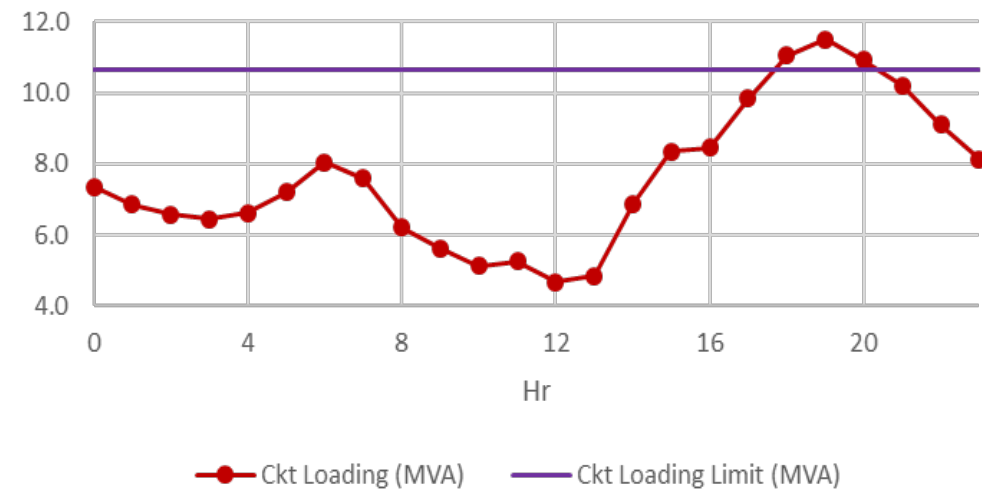

2023 East Kapolei Contingency Overload

Kapolei 2 Tsf, Loss of Kamokila 2 Tsf

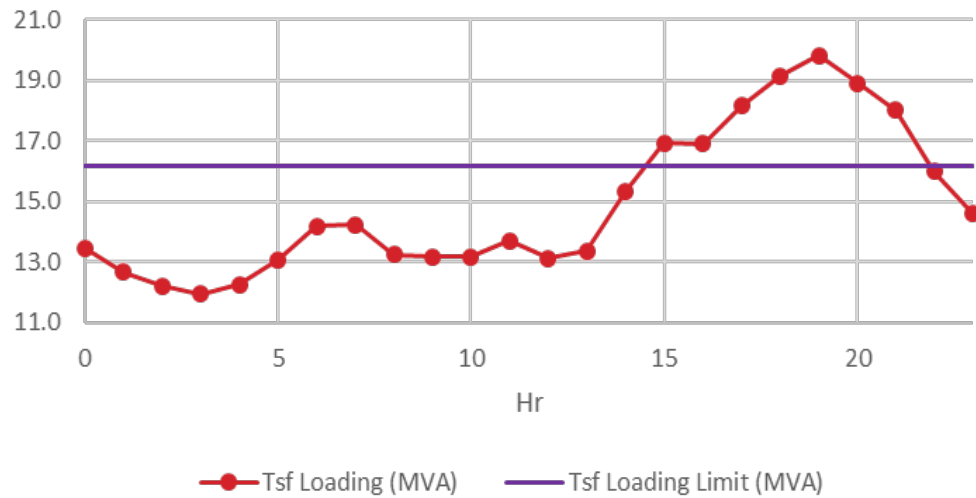

Kapolei 4 Ckt, Loss of Kamokila 2 Tsf

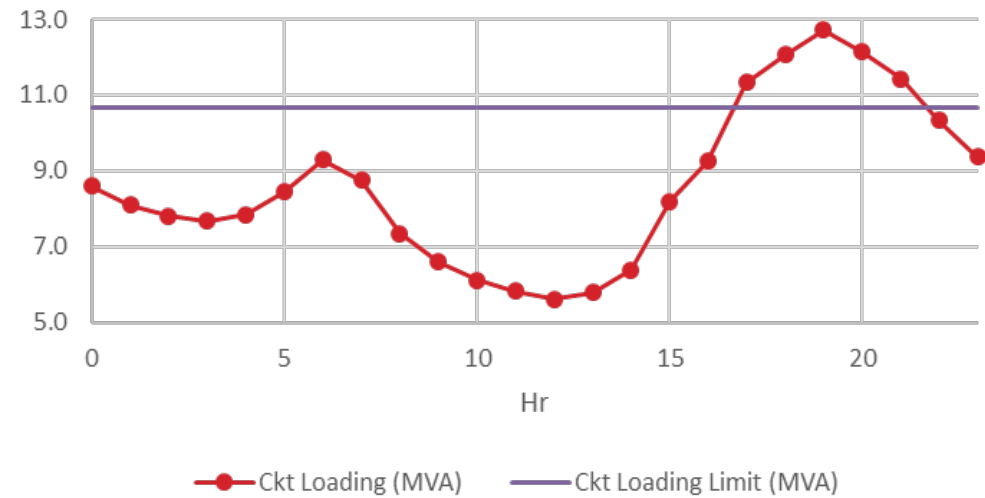

2024 East Kapolei Contingency Overload

Kapolei 2 Tsf, Loss of Kamokila 2 Tsf

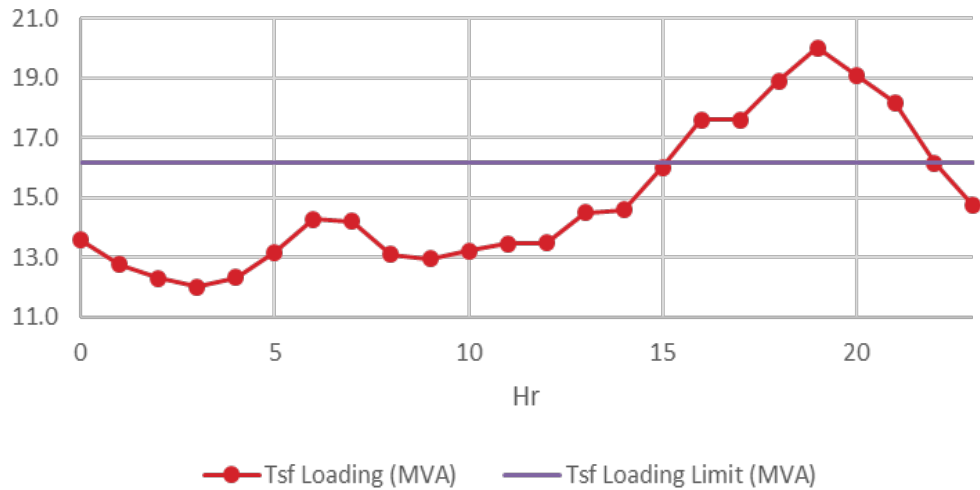

Kapolei 4 Ckt, Loss of Kamokila 2 Tsf

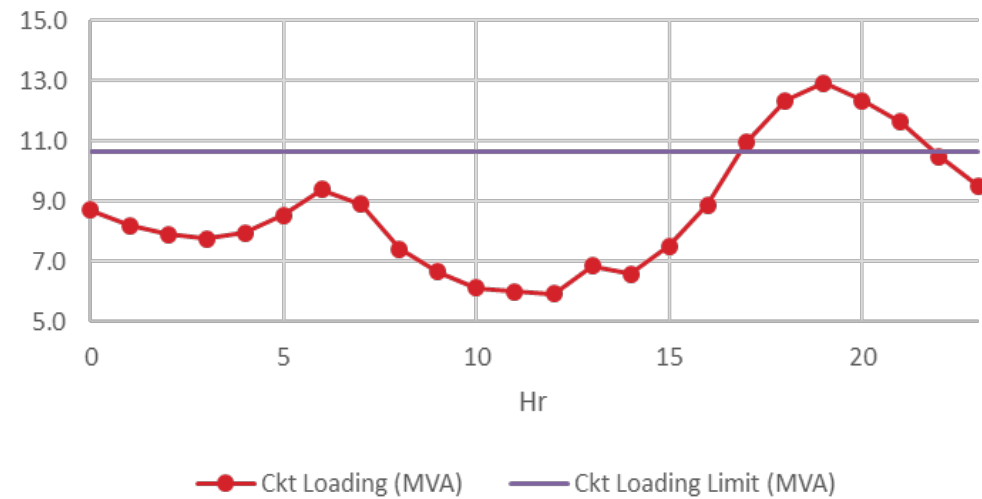

East Kapolei Area Review – Wires Solution

◆ Wires Solution

- ◆ Approximate 1 mile underground circuit line and ducts extension into the East Kapolei area for additional circuit capacity

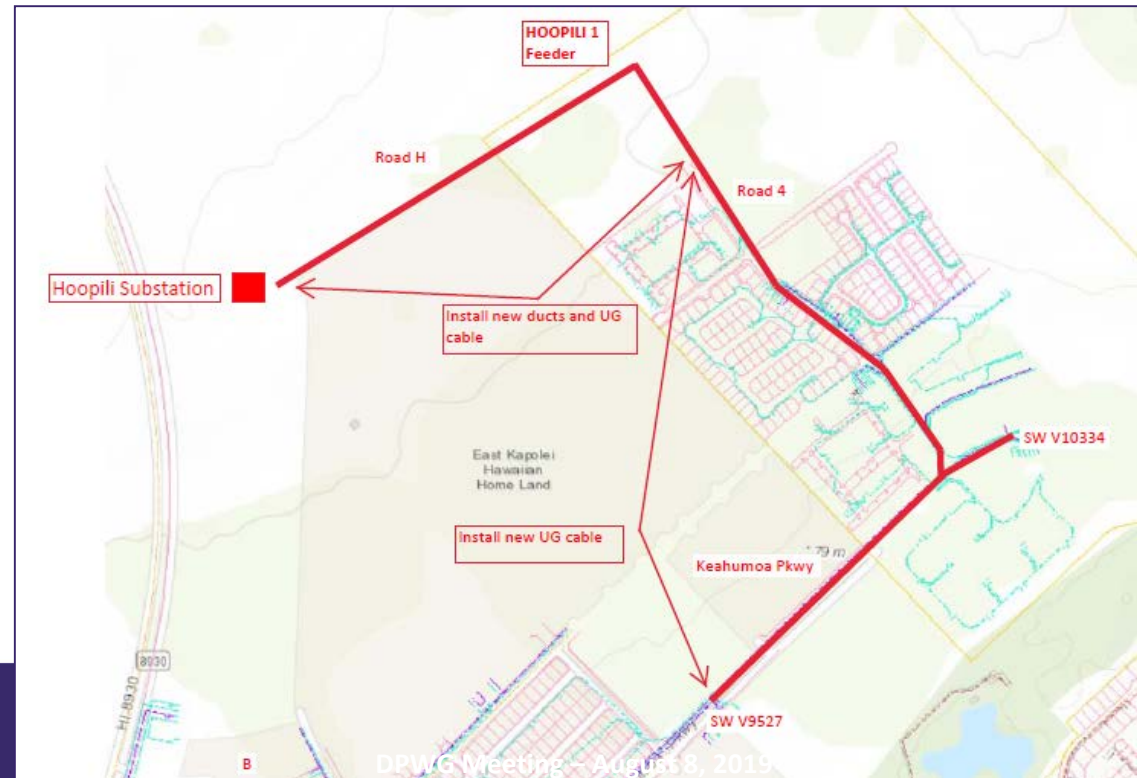

East Kapolei Need

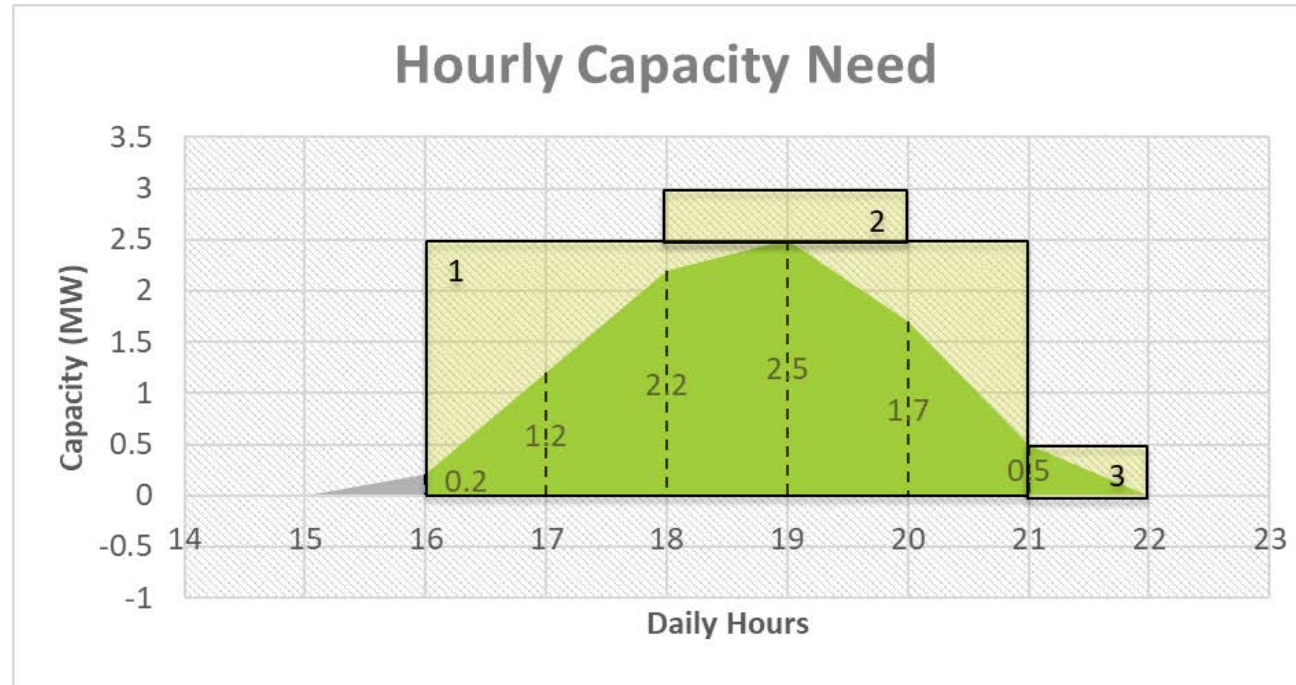

Need	Capacity (MW)	Delivery Months	Delivery Hours	Hours Duration	Maximum # of Calls per year
1	1, 1.5, or 2.5	Jan – Dec	4PM – 9PM	5	365
2	0.5 (100kW inc.)	Jan – Dec	6PM – 8PM	2	365
3	0.5 (100kW inc.)	Jan – Dec	9PM – 10PM	1	365



East Kapolei Avoided Cost

	Estimated Cumulative Capital Deferral Value ¹ (\$)	Estimated Capacity ² (MW)
1-Year Deferral	\$524,702	3
2-Year Deferral	\$1,014,932	3
3-Year Deferral	\$1,472,954	3
4-Year Deferral	\$1,900,884	3
5-Year Deferral	\$2,300,699	3

PRELIMINARY

¹Accumulated NPV of annual revenue requirement for 1 circuit (~ \$6M total cost)

²Estimated capacity based on peak N-1 overload

Soft Launch Update



Hawaiian Electric
Maui Electric
Hawai'i Electric Light

Soft Launch RFP Tentative Timeline

2019 Milestones	Proposed Date
Draft RFP Release	September 3, 2019
Stakeholder Meeting	Week of September 9, 2019
Comment Period	Week of September 23, 2019
Final RFP Issue	October 15, 2019
Proposal Due Date	December 17, 2019



Soft Launch RFP Timing

- ◆ Soft Launch Evaluation of IFTM and BTM resources is more complex
 - ◆ Different types of solutions (aggregators, generation, storage, etc.)
- ◆ Schedule assumes:
 - ◆ No Company Self-build
 - ◆ No Competitive Bidding Framework, relevant concepts incorporated into RFP. Did not include provision for:
 - ◆ PUC approval of Soft Launch RFP prior to issuance
 - ◆ Independent Observer
 - ◆ Expedited Contract Negotiations – Proposers substantially adopt form contracts
 - ◆ Expedited PUC Approval of Resulting Contract (3 months or less)



Next Steps



Hawaiian Electric
Maui Electric
Hawai'i Electric Light

Next Steps

- ◆ September (tbd) – Soft Launch RFP Stakeholder Meeting
 - ◆ Next steps on Soft Launch RFP will follow procurement schedule
- ◆ October (tbd) – DPWG Mtg:
 - ◆ Initiate Discussion of Potential T&D NWA Opportunities for 2020
 - ◆ Continue Discussion of Proposed IGP NWA Opportunity Assessment & Needs Identification Process
- ◆ November (tbd) – DPWG Mtg:
 - ◆ Review 2020 T&D NWA Opportunities Assessment & Prioritization
- ◆ January (tbd) – DPWG:
 - ◆ Finalize IGP NWA Opportunity Assessment & Needs Identification Process





Questions & Feedback



Hawaiian Electric
Maui Electric
Hawai'i Electric Light