

BEFORE THE PUBLIC UTILITIES COMMISSION

OF THE STATE OF HAWAII

In The Matter of the Requests of)
)
HAWAIIAN ELECTRIC COMPANY, INC.,) DOCKET NO. 2017-0352
HAWAII ELECTRIC LIGHT COMPANY, INC.,)
AND MAUI ELECTRIC COMPANY, LIMITED)
)
To Instituting a Proceeding Relating to a)
Competitive Bidding Process to Acquire)
Dispatchable and Renewable Generation)
_____)

**Hawaiian Electric Companies’
Proposed Final Stage 2
Renewable and Grid Services RFPs**

Book 5 of 7

Filed August 22, 2019

EXHIBIT 3

Final Variable Renewable Dispatchable Generation and Energy Storage Stage 2 RFP for the Island of Hawai'i, including the final model RDG PPA for both PV and wind, and the Energy Storage PPA ("ESPPA")

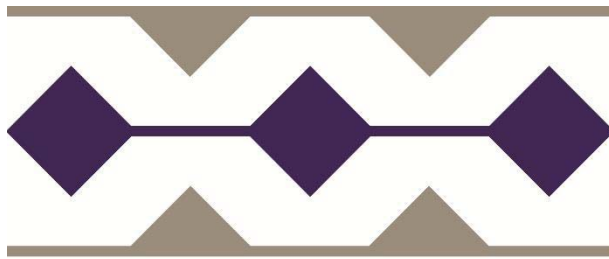

**Hawai'i
Electric
Light**

**REQUEST FOR PROPOSALS
FOR
VARIABLE RENEWABLE DISPATCHABLE GENERATION
AND
ENERGY STORAGE
ISLAND OF HAWAI'I**

AUGUST 22, 2019

Docket No. 2017-0352

Table of Contents

Chapter 1: Introduction and General Information	1
1.1 Authority and Purpose of the Request for Proposals	2
1.2 Scope of the RFP	2
1.3 Competitive Bidding Framework	7
1.4 Role of the Independent Observer	7
1.5 Communications Between the Company and Proposers – Code of Conduct Procedures Manual.....	8
1.6 Company Contact for Proposals	8
1.7 Proposal Submittal Requirements.....	8
1.8 Proposal Fee.....	10
1.9 Procedures for the Self-Build or Affiliate Proposals	11
1.10 Dispute Resolution Process.....	13
1.11 No Protest or Appeal.....	14
1.12 Modification or Cancellation of the Solicitation Process	14
Chapter 2: Resource Needs and Requirements	14
2.1 Performance Standards	14
2.2 Transmission System	15
2.3 Interconnection to the Company System	15
Chapter 3: Instructions to Proposers	17
3.1 Schedule for the Proposal Process	17
3.2 Company RFP Website / Electronic Procurement Platform.....	17
3.3 Information Conferences	18
3.4 Preparation of Proposals	18
3.5 Organization of the Proposal	19
3.6 Proposal Limitations	19
3.7 Proposal Compliance and Bases for Disqualification.....	20
3.8 Power Purchase Agreement	20
3.9 Pricing Requirements.....	22
3.10 Project Description.....	24
3.11 Sites Identified by the Company.....	25
3.12 Confidentiality	26

3.13	Credit Requirements Under the PPA	27
Chapter 4: Evaluation Process and Evaluation Criteria		27
4.1	Proposal Evaluation and Selection Process	27
4.2	Eligibility Requirements Assessment	29
4.3	Threshold Requirements Assessment	30
4.4	Initial Evaluation – Price and Non-Price Analysis	33
4.5	Selection of a Priority List	39
4.6	Best and Final Offer (BAFO)	40
4.7	Detailed Evaluation.....	40
4.8	Selection of the Final Award Group	42
Chapter 5: Post Evaluation Process		43
5.1	Interconnection Requirements Study.....	43
5.2	Contract Negotiation Process.....	45
5.3	Community Outreach and Engagement	45
5.4	Greenhouse Gas Emissions Analysis	46
5.5	PUC Approval of PPA	47
5.6	Facility In-Service.....	47

List of Appendices

Appendix A	Definitions
Appendix B	Proposer's Response Package / IRS Data Sheet
Appendix C	Code of Conduct Procedures Manual
Appendix D	PowerAdvocate User Information
Appendix E	Mutual Confidentiality and Non-Disclosure Agreement
Appendix F	Description of Available Sites
Appendix G	Self-Build Option and Self Build Option Team Certification Form
Appendix H	Interconnection Facilities and Cost Information
Appendix I	Rule 19 Tariff
Appendix J	Model PV RDG PPA
Appendix K	Model ESPPA
Appendix L	Model Wind RDG PPA

Chapter 1: Introduction and General Information

Hawai‘i Electric Light Company, Inc. (“Hawai‘i Electric Light” or the “Company”) seeks proposals for the supply of qualified variable renewable dispatchable generation and energy storage for the Hawai‘i Electric Light System in accordance with this Request for Proposals (“RFP”).¹ The total amount of variable renewable dispatchable generation being solicited in this RFP is the capability to provide up to 444,000 megawatt hours (“MWh”) annually. Additionally a total of 18 megawatts (“MW”) of Fast Frequency Response (as defined in [Appendix J, K, and L](#)) is being solicited which may either be fulfilled through standalone contingency reserve storage projects or generation projects paired with storage proposed in response to this RFP or through Fast Frequency Response 1 (“FFR-1”) capability on Hawai‘i island bid into the Companies’ RFP for Delivery of Grid Services from Customer-Sited Distributed Energy Resources (“Grid Services RFP”).

The Company or its Affiliate may submit a Proposal in response to this RFP subject to the requirements of this RFP.

The Company seeks variable renewable dispatchable generation projects (with or without storage systems) and standalone energy storage projects in this RFP. However any photovoltaic (“PV”) projects must be paired with a storage component. The Company intends to contract for variable renewable dispatchable generation projects through this RFP using its Model Renewable Dispatchable Generation Power Purchase Agreement (“RDG PPA”), which treats variable generation facilities as fully dispatchable. The Company has created a photovoltaic (“PV”) version (the “PV RDG PPA”) and a wind version (the “Wind RDG PPA”) of its RDG PPA attached as [Appendix J](#) and [Appendix L](#) respectively.² If the proposed Project utilizes a technology other than PV or wind and/or contains components that are not encompassed by the RDG PPA, then the terms of the RDG PPA will be modified to address the specific technology and/or component.

The Company intends to contract for standalone energy storage projects through this RFP using its Model Energy Storage Power Purchase Agreement (“ESPPA”), pursuant to which Hawai‘i Electric Light will purchase energy storage services (i.e., Fast Frequency Response and ancillary services). The ESPPA is attached as [Appendix K](#).²

Each successful Proposer will provide variable renewable dispatchable generation and/or energy storage to the Company pursuant to the terms of an RDG PPA or ESPPA, which will be subject to PUC review and approval by the State of Hawai‘i Public Utilities Commission (“PUC”).

The Company will evaluate Proposals using the evaluation and selection process described in [Chapter 4](#). The Company will evaluate and select Proposals based on both price and non-price factors that impact the Company, its customers, and communities affected by the proposed Projects. The amount of generation and storage that the Company may acquire from this RFP depends on, among other things, the quality and cost-effectiveness of bids received in response to this RFP; economic comparison to other RFP responses; updates to the Company’s forecasts;

¹ The Company is soliciting proposals for renewable dispatchable generation and energy storage in stages. The “Stage 1” RFPs were conducted in 2018. This is part of the “Stage 2” RFPs to be conducted in 2019.

² The RDG PPA for PV and Wind, and ESPPA for standalone energy storage, are available on the Company’s RFP website and through the PowerAdvocate platform for the RFP.

transmission availability; and changes to regulatory or legal requirements. If attractive Proposals are received that will provide energy and energy storage in excess of the targeted amounts, the Company will consider selecting such Proposal(s) if benefits to customers are demonstrated.

All requirements necessary to submit a Proposal(s) are stated in this RFP. A description of the technical requirements for Proposers is included in the body of this RFP, Appendix B, and in the RDG PPA and ESPPA attached as Appendix J, K, and L.

All capitalized terms used in this RFP shall have the meaning set forth in the glossary of defined terms attached as Appendix A. Capitalized terms that are not included in Appendix A shall have the meaning ascribed in this RFP.

1.1 Authority and Purpose of the Request for Proposals

- 1.1.1 This RFP is issued in response to Order No. 36474 issued on August 15, 2019 in Docket No. 2017-0352 as part of a procurement process established by the PUC.
- 1.1.2 This RFP is subject to Decision and Order (“D&O”) No. 23121 in Docket No. 03-0372 (To Investigate Competitive Bidding for New Generating Capacity in Hawai‘i), which sets forth the PUC’s Framework for Competitive Bidding (“Framework” or “Competitive Bidding Framework”).
- 1.1.3 All Proposals with a generation component submitted in response to this RFP must utilize qualified renewable energy resource(s) as defined under the Hawai‘i Renewable Portfolio Standards (“RPS”) law.³ By statute, “Renewable Energy” means energy generated or produced using the following sources: (1) wind; (2) the sun; (3) falling water; (4) biogas, including landfill and sewage-based digester gas; (5) geothermal; (6) ocean water, currents, and waves, including ocean thermal energy conversion; (7) biomass, including biomass crops, agricultural and animal residues and wastes, and municipal solid waste and other solid waste; (8) biofuels; and (9) hydrogen produced from renewable energy sources.⁴
- 1.1.4 Proposers should review the Hawaiian Electric Companies’ Power Supply Improvement Plans, filed in Docket No. 2014-0183 on December 23, 2016 (“PSIP Update Report: December 2016” or “PSIP”). Consistent with the PSIP, the primary purpose of this RFP is to obtain variable renewable energy and energy storage so that the Company can continue to transform Hawai‘i’s power supply portfolio from fossil fuel-based generation to renewable-based generation to meet Hawai‘i’s 100% RPS requirement.

1.2 Scope of the RFP

- 1.2.1 Proposers should note and will be required to expressly acknowledge in their Proposals that the Company reserves the right, per PUC Order 36536, to select less than the full amount of generation solicited in this RFP in the event that specific HELCO system needs (e.g. as a result of the availability of either or both of the Puna Geothermal

³ RPS requirements in Hawai‘i are codified in Hawai‘i Revised Statutes (“HRS”) §§ 269-91 through 269-95.

⁴ See HRS § 269-91.

Ventures (“PGV”) and Hu Honua Bioenergy (“Hu Honua”) facilities) are revised during the course of the RFP process.

- 1.2.2 The Company does not have a predetermined preference for a particular renewable energy generation or storage technology.
- 1.2.3 Each Proposal submitted in response to this RFP must represent a Project that is capable of meeting the requirements of this RFP without having to rely on the completion or implementation of any other Project.
- 1.2.4 Proposals that will require system upgrades and the construction of which, in the reasonable judgment of the Company (in consultation with the Independent Observer), creates a significant risk that their Project’s Guaranteed Commercial Operations Date (“GCOD”) will not be met will not be considered in this RFP.
- 1.2.5 Projects submitted in response to this RFP must be located on the Island of Hawai‘i.
- 1.2.6 Proposers will determine their Project Site. Proposers have the option of submitting a Proposal using potential Sites offered and described in Section 3.11. Proposers must locate all Project infrastructure within areas of their Site that are outside the 3.2 feet sea level rise exposure area (SLR-XA) as described in the Hawai‘i Sea Level Rise Vulnerability and Adaptation Report (2017)⁵ and are not located within a Tsunami Evacuation Zone.⁶
- 1.2.7 Projects must interconnect to the Company’s System at the 69 kV level, with the exception of standalone storage projects proposed at the Company-owned Puna Site which may interconnect to the Company system at the 13.8 kV level as described in Appendix F.
- 1.2.8 Projects’ size must be greater than the threshold for a waiver from the Competitive Bidding Framework applicable to Hawai‘i island. No single point of failure from the Facility shall result in a decrease in net electrical output greater than 30 MW. Additionally, in meeting the single point of failure requirement, if the Facility exceeds 30 MW, the Facility must be segmented in equally sized capacities (MW). Each segment must have its own point of interconnection into the Hawai‘i Electric Light system that can be independently dispatched via the Company’s energy management system. Revisions would need to be made to the RDG PPA or the ESPPA to account for multiple points of interconnection.

⁵ Hawai‘i Climate Change Mitigation and Adaptation Commission. 2017. Hawai‘i Sea Level Rise Vulnerability and Adaptation Report. Prepared by Tetra Tech, Inc. and the State of Hawai‘i Department of Land and Natural Resources, Office of Conservation and Coastal Lands, under the State of Hawai‘i Department of Land and Natural Resources Contract No: 64064. This report is available at: https://climateadaptation.hawaii.gov/wp-content/uploads/2017/12/SLR-Report_Dec2017.pdf

⁶ See Hawai‘i Sea Level Rise Viewer at <https://www.pacioos.hawaii.edu/shoreline/slr-hawaii/>, and National Oceanic and Atmospheric Administration (NOAA) interactive map in partnership with the State of Hawai‘i at <https://tsunami.coast.noaa.gov/#/>.

- 1.2.9 Standalone contingency reserve energy storage projects must be 3 MW, 6 MW, 9 MW, or 12 MW in size.
- 1.2.10 Standalone contingency reserve energy storage projects must also support a switchable mode of operation to allow it to also be used for energy.
- 1.2.11 Contracts for projects that include a generation component selected through this RFP shall use the RDG PPA, as described in Section 3.8. Under the RDG PPA, the Company will maintain exclusive rights to fully direct dispatch of the Facility, subject to availability of the resource and Section 1.2.13 below.
- 1.2.12 Contracts for standalone contingency reserve energy storage projects selected through this RFP shall use the ESPPA, as described in Section 3.8. Under the ESPPA, the Company will maintain exclusive rights to fully direct the charging and discharging of the Facility. Additionally, due to the critical nature and usage of this to support the grid, the ability to control and tune the facility's response to certain grid events and conditions is an important aspect that will be required of these facilities.
- 1.2.13 Generation proposals may be submitted either with or without an energy storage component. However PV projects must be paired with an energy storage component. The energy storage component can be charged during periods when full potential export of the generation Facility is not being dispatched by the Company, and the storage component can be used to provide energy to the Company during other times that are beneficial to the system. Generation proposals paired with an energy storage component may propose an additional contingency storage component to provide the Fast Frequency Response ("Contingency Storage") whose amount is to be specified by Proposer. The amount of Contingency Storage must be 3 MW, 6 MW, 9 MW, or 12 MW in size. The energy storage component must be sized to support the Facility's Allowed Capacity (in MW) for a minimum of four (4) continuous hours throughout the term of the PPA.⁷ The Contingency Storage component must be sized to provide a minimum of one (1) continuous hour at the proposed MW amount throughout the term of the PPA.

For example, for a 10 MW facility, the energy storage component must be able to store and discharge at least 40 MWh of energy in a cycle throughout the term of the PPA. If a project proposes an additional 3 MW of Contingency Storage this component must be able to store and discharge at least 3 MWh of energy in a cycle throughout the term of the PPA.

- 1.2.14 Generation proposals that include Contingency Storage must be segregated such that the contingency capacity (FFR mode) is held separate from the load shifting capacity as set forth in Appendix B to the RDG PPA.
- 1.2.15 Generation proposals with Contingency Storage will require a separate interface to control and separately manage the Fast Frequency Response portion to be charged and held in reserve.

⁷ PPA throughout this RFP refers to either/both the RDG PPA or ESPPA.

- 1.2.16 Energy storage components that are paired with a generation Facility must also be able to be charged from the grid at the direction of the Company as described in this section. To be eligible to meet this RFP's Fast Frequency Response need the Contingency Storage must be grid-chargeable from the guaranteed commercial operation date ("GCOD").

For energy storage components that are paired with generating facilities, during the period that allows the Project to maximize and capture the benefits of the federal Investment Tax Credit ("ITC") for the energy storage system, the Proposer can design and specify the amount, if any, of grid charging for the energy storage system. However, after the 5-year ITC recapture period has lapsed, any energy storage component paired with generation must be capable of being 100% charged from the grid at the direction of the Company.

Energy storage components that are paired with generating facilities that are incapable of claiming the ITC must be capable of being 100% charged from the grid from the GCOD.

For example, during the 5-year ITC recapture period, a Proposer pairing an energy storage component with a solar facility can specify that its Facility can be charged from the grid (at the direction of the Company) up to 20% of its annual total energy input. After the 5-year ITC recapture period has lapsed, the energy storage component must be capable of being charged up to 100% of its total energy input from the grid at the direction of the Company.

- 1.2.17 Proposals for standalone energy storage will provide contingency reserve and energy to the Company during times that are deemed by the Company to be beneficial to the system. These facilities must be connected to the grid at all times, with the exception of allowed maintenance periods. Proposals must be sized to support the Facility's Allowed Capacity (in MW) for a minimum of one (1) continuous hour throughout the term of the ESPPA.

For example, for a 10 MW facility, the energy storage component must be able to store and discharge at least 10 MWh of energy in a cycle throughout the term of the ESPPA.

- 1.2.18 The amount of energy discharged in a year from an energy storage component paired with a generation component will be limited to the energy storage contract capacity (in MWh) multiplied by the number of Days in that year.

- 1.2.19 For standalone contingency reserve storage or Contingency Storage, the storage technology will be selected based on the required charging/discharging duty for the provision of disturbance frequency response. This response will require fast response outside of a specified frequency deadband (setable between .1-.5 Hz), in accordance with specified droop and time parameters. Historical frequency data for 2 second data resolution samples will be provided to bidders and is summarized in Attachment 1 of the Companies' Reliability Standards Working Group Monthly Report in Docket 2011-0206. Additionally, Proposers with an executed Non-Disclosure Agreement with the Company in the form of RFP Appendix E may request the raw data used to create the summary plots included in the monthly reports. Proposers should carefully review such data to

ensure their Proposal meets the needs of the Company System. The proposed Facility’s ability to meet the Company’s Fast Frequency Response need will be evaluated as a part of the Performance Standards non-price criterion.

- 1.2.20 Proposals for standalone contingency reserve energy storage and generation projects with Contingency Storage must specify a GCOD no later than December 31, 2022.
- 1.2.21 Proposals for generation only or generation paired with energy storage must specify a GCOD no later than December 31, 2025. However, Proposals with earlier GCODs will be given preference in scoring.

Project Technology	Generation Only	Generation Paired w/ Storage	Generation Paired w/ Contingency Storage	Standalone Contingency Reserve Storage
GCOD	December 31, 2025	December 31, 2025	December 31, 2022	December 31, 2022
Grid Charging	N/A	100% after ITC period	100% at GCOD for Contingency Storage 100% after ITC period for energy storage	100% at GCOD

- 1.2.22 A Proposer’s GCOD set forth in its Proposal will be the GCOD in any resulting PPA if such Proposal is selected to the Final Award Group. Proposers will not be able to request a change in the GCOD set forth in their Proposals.
- 1.2.23 If selected, Proposers will be responsible for all costs throughout the term of the PPA, including but not limited to Project development, completion of an Interconnection Requirements Study (“IRS”), the cost of conducting a greenhouse gas analysis, land acquisition, permitting, financing, construction of the Facility and all Interconnection Facilities, and operations and maintenance (“O&M”).
- 1.2.24 If selected, Proposers will be solely responsible for the decommissioning of the Project and the restoration of the Site upon the expiration of the PPA, as described in Attachment G, Section 7 of the RDG PPA or ESPPA.
- 1.2.25 If selected, Proposers shall pursue all available applicable federal and state tax credits. Proposal pricing must be set to incorporate the benefit of such available federal tax credits. However, to mitigate the risk on Proposers due solely to potential changes to the state’s tax credit law before a selected project reaches commercial operations, Proposal pricing shall be set without including any state tax credits. If a Proposal is selected, the PPA for the project will require the Proposer to pursue the maximum available state tax credit and remit tax credit proceeds to the Company for customers’ benefit as described in Attachment J of the RDG PPA or ESPPA. The PPA will also

provide that the Proposer will be responsible for payment of liquidated damages for failure to pursue the state tax credit.

- 1.2.26 Each Proposal submitted in response to this RFP must represent a Project that is capable of meeting the requirements of this RFP without having to rely on a proposed change in law, rule, or regulation.

1.3 Competitive Bidding Framework

Consistent with the Framework, this RFP outlines the Company's requirements in relation to the resources being solicited and the procedures for conducting the RFP process. It also includes information and instructions to prospective Proposers participating in and responding to this RFP.

1.4 Role of the Independent Observer

- 1.4.1 Part III.C.1 of the Framework sets forth the circumstances under which an Independent Observer is required in a competitive bidding process. The PUC has retained an Independent Observer both to advise and monitor the process for this RFP. All phases of the RFP process will be subject to the Independent Observer's oversight, and the Independent Observer will coordinate with PUC staff throughout the RFP process to ensure that the RFP is undertaken in a fair and unbiased manner. In particular, the Company will review and discuss with the Independent Observer decisions regarding the evaluation, disqualification, non-selection, and selection of Proposals.
- 1.4.2 The role of the Independent Observer, as described in the Framework, will include but is not limited to:
- Monitor all steps in the competitive bidding process
 - Monitor communications (and communications protocols) with Proposers
 - Monitor adherence to the Company's Code of Conduct
 - Submit comments and recommendations, if any, to the PUC concerning the RFP
 - Review the Company's Proposal evaluation methodology, models, criteria, and assumptions
 - Review the Company's evaluation of Proposals
 - Advise the Company on its decision-making
 - Participate in dispute resolution as set forth in Section 1.10
 - Monitor contract negotiations with Proposers
 - Report to the PUC on monitoring results during each stage of the competitive bidding process
 - Provide an overall assessment of whether the goals of the RFP were achieved
- 1.4.3 The Independent Observer for this RFP is **Bates White, LLC**.

1.5 Communications Between the Company and Proposers – Code of Conduct Procedures Manual

- 1.5.1 Communications and other procedures under this RFP are governed by the “Code of Conduct Procedures Manual,” (also referred to as the “Procedures Manual”) developed by the Company as required by the Framework, and attached as Appendix C.
- 1.5.2 All pre-Proposal communication with prospective Proposers will be conducted via the Company’s RFP website, Electronic Procurement Platform and/or electronic mail (“Email”) through the address specified in Section 1.6 (the “RFP Email Address”). Frequently asked questions submitted by prospective Proposers and the answers to those questions may be posted on the Company’s RFP website, or sent through either Email or the Electronic Procurement Platform to registered individuals. The Company reserves the right to respond only to comments and questions it deems are appropriate and relevant to the RFP. Proposers are advised to submit questions no later than fifteen Days before the Proposal Due Date (RFP Schedule in Section 3.1, Items 7 and 8). The Company will endeavor to respond to all questions no later than five Days before the Proposal Due Date.
- 1.5.3 After Proposals have been submitted, the Company may contact individual Proposers for purposes of clarifying their Proposal(s).
- 1.5.4 Any confidential information deemed by the Company, in its sole discretion, to be appropriate to share, will only be transmitted to the requesting party after receipt of a fully executed Stage 2 Mutual Confidentiality and Non-Disclosure Agreement (“NDA”). See Appendix E.
- 1.5.5 Except as expressly permitted and in the manner prescribed in the Procedures Manual, any unsolicited contact by a Proposer or prospective Proposer with personnel of the Company pertaining to this RFP is prohibited.

1.6 Company Contact for Proposals

The primary contact for this RFP is:

Reese Yorimoto
Energy Contract Manager
Hawaiian Electric Company, Inc.
Central Pacific Plaza Building, Suite 2100
220 South King Street
Honolulu, Hawai‘i 96813

RFP Email Address: hawaiivariablyrfp@hawaiianelectric.com

1.7 Proposal Submission Requirements

- 1.7.1 All Proposals must be prepared and submitted in accordance with the procedures and format specified in the RFP. Proposers are required to respond to all questions and

provide all information requested in the RFP, as applicable, and only via the communication methods specified in the RFP.

- 1.7.2 Detailed requirements regarding the form, submission, organization and information for the Proposal are set forth in Chapter 3 and Appendix B.
- 1.7.3 In submitting a Proposal in response to this RFP, each Proposer certifies that the Proposal has been submitted in good faith and without fraud or collusion with any other unaffiliated person or entity. The Proposer shall acknowledge this in the Response Package submitted with its Proposal. Furthermore, in executing the NDA provided as Appendix E, the Proposer agrees on behalf of its Representatives (as defined in the NDA) that the Company's negotiating positions will not be shared with other Proposers or their respective Representatives.

In addition, in submitting, a Proposal, a Proposer will be required to provide Company with its legal counsel's written certification in the form attached as Appendix B Attachment 1 certifying in relevant part that irrespective of any proposer's direction, waiver, or request to the contrary, that the attorney will not share a proposer's confidential information associated with such proposer with others, including, but not limited to, such information such as a proposer's or Company's negotiating positions. If legal counsel represents multiple unaffiliated proposers whose Proposals are selected for the Final Award Group, such counsel will also be required to submit a similar certification at the conclusion of power purchase agreement negotiations that he or she has not shared a proposer's confidential information or the Company's confidential information associated with such proposer with others, including but not limited to, such information as the a proposer's or Company's negotiating positions.

- 1.7.4 Proposals must be submitted via the Electronic Procurement Platform by 2:00 pm Hawai'i Standard Time (HST) on the Proposal Due Date shown in the RFP Schedule in Section 3.1. No hard copies of the Proposals will be accepted.⁸ It is the Proposer's sole responsibility to ensure that complete and accurate information has been submitted on time and within the instructions of this RFP. With this assurance, Company shall be entitled to rely upon the completeness and accuracy of every Proposal. Any errors identified by the Proposer or Company after the Proposal Due Date has passed may jeopardize further consideration and success of the Proposal. If an error or errors are later identified, Company, in consultation with the Independent Observer, may permit the error(s) to be corrected without further revision to the Proposal, or may require Proposer to adhere to terms of the Proposal as submitted without correction. Additionally, and in Company's sole discretion, if such error(s) would materially affect the Priority List or Final Award Group, Company reserves the right, in consultation with the Independent Observer, to remove or disqualify a Proposal upon discovery of the material error(s). The Proposer of such Proposal shall bear the full responsibility for such error(s) and shall have no recourse against Company's decision to address Proposal error(s), including removal or disqualification. The Energy Contract Manager, in consultation with the

⁸ Proposals for the SBO(s) and Affiliate Proposals have additional submission requirements to the PUC specified in Section 1.9 below.

Independent Observer, will confirm that the Self-Build and Affiliate Proposals are timestamped by milestone (7) Self-Build and Affiliate Proposal Due Date in Section 3.1 Table 1. The PowerAdvocate Platform automatically closes further submissions after milestone (8) IPP Proposal Due Date in Table 1.

1.8 Proposal Fee

- 1.8.1 IPP and Affiliate proposers are required to tender a non-refundable Proposal Fee of \$10,000 for each Proposal submitted. IPP and Affiliate proposers who propose projects located at the Company-owned site identified in Section 3.11.2 will have their Proposal Fee waived.
- 1.8.2 Proposers may submit multiple Proposal variations for a Project for a single Proposal Fee. If such Proposals are on different Sites or for different generation technologies, a separate Proposal Fee must be paid for each Proposal. The method of submitting multiple Proposals within this RFP is described in Appendix B.
- 1.8.3 Proposers may also submit up to a total of four (4) variations of their Proposal, one variation of which is the base variation of the Proposal. In addition, for each of the 4 variations the Proposer may propose an additional variation with Contingency Storage, where the only change is the addition of a Contingency Storage component and any needed changes to account for the addition of the Contingency Storage.⁹ Variations of pricing terms, Facility size, or with/without storage can be offered. All variations within a Proposal must be proposed on the same Site and using the same generation technology to avoid paying a separate Proposal Fee. Whether or not a separate Proposal Fee is required, all unique information for each variation of a Proposal, no matter how minor such variation is, must be clearly identified and separated by following the instructions in Appendix B Section 3.
- 1.8.4 The Proposal Fee must be in the form of a cashier's check or equivalent from a U.S.-chartered bank made payable to "Hawai'i Electric Light Company, Inc." and must be delivered and received by the Company by 2:00 pm (HST) on the Proposal Due Date shown in the RFP Schedule in Section 3.1. The check should include a reference to the Proposal(s) for which the Proposal Fee is being provided. Proposers are strongly encouraged to utilize a delivery service method that provides proof of delivery to validate delivery date and time.

If the Proposal Fee is delivered by U.S. Postal Service (with registered, certified, receipt verification), the Proposer shall address it to:

Reese Yorimoto
Energy Contract Manager
Hawaiian Electric Company, Inc.
Mail Code CP21-IU

⁹ For each variation that includes Contingency Storage, it is to the Proposer's advantage to offer an identical variation without Contingency Storage as Proposals with Contingency Storage must be selected through both evaluation processes (energy and Contingency Storage) in order to advance to the Final Award Group.

PO Box 2750
Honolulu, Hawai'i 96840

If the Proposal Fee is delivered in person, or via an alternative registered, certified delivery service, the Proposer shall use the address specified in Section 1.6.

1.9 Procedures for the Self-Build or Affiliate Proposals

The Competitive Bidding Framework allows the Company the option to offer a Proposal(s) in response to this RFP ("Self-Build Option" or "SBO"). Accordingly, the Company must follow certain requirements and procedures designed to safeguard against and address concerns associated with: (1) preferential treatment of the SBO or members, agents or consultants of the Company formulating the SBO (the "Self-Build Team"); and (2) preferential access to proprietary information of the Self-Build Team. These requirements are specified in the Code of Conduct required under the Framework and implemented by certain rules and procedures found in the Procedures Manual submitted to the PUC in Docket No. 2017-0352 on April 1, 2019. A copy of the Procedures Manual is attached as Appendix C.

The Competitive Bidding Framework also allows Affiliates of the Company to submit Proposals to RFPs issued by the Company. All Self-Build and Affiliate Proposals are subject to the Company's Code of Conduct and the Procedures Manual. Affiliate Proposals are also subject to any applicable Affiliate Transaction Requirements issued by the PUC in Decision and Order No. 35962 on December 19, 2018, and subsequently modified by Order No. 36112, issued on January 24, 2019, in Docket No. 2018-0065. Affiliate Proposals will be treated identically to an IPP proposal, except that they are due at the same time as any Self-Build Proposal(s).

The Independent Observer will monitor adherence to the Company's Code of Conduct and the Procedures Manual. Pursuant to the Framework and as set forth in the RFP Schedule, the Company will require that the Proposal for the SBO(s) and Affiliate Proposals be submitted electronically through the Electronic Procurement Platform and filed with the PUC in hard copy a minimum of one (1) Day before other Proposals are due. (A Proposal for the SBO or Affiliate will be uploaded into the Electronic Procurement Platform in the same manner Proposals from other Proposers are uploaded. The Energy Contract Manager, in consultation with the Independent Observer, will confirm that the Self-Build and Affiliate Proposals are timestamped by Milestone (7) Self-Build and Affiliate Proposal Due Date in RFP Table 1.)

Detailed requirements for an SBO Proposal can be found in Appendix G. These requirements are intended to provide a level playing field between SBO Proposals and third-party Proposals. Except where specifically noted, a SBO Proposal must adhere to the same price and non-price Proposal requirements as required of all Proposers, as well as certain PPA requirements, such as milestones and liquidated damages, as described in Appendix G. The non-negotiability of the Performance Standards shall apply to any SBO to the same extent it would for any other Proposal. Notwithstanding the fact that it will not be required to enter into an RDG PPA or ESPPA with the Company, a Self-Build

Proposer will be required to note its exceptions, if any, to the RDG PPA and/or ESPPA in the same manner required of other Proposers, and will be held to such modified parameters if selected. In addition to its Proposal, the Self-Build Team will be required to submit Appendix G Attachment 1, Self-Build Option Team Certification Form, acknowledging it has followed the rules and requirements of the RFP to the best of its ability and has not engaged in any collusive actions or received any preferential treatment or information providing an impermissible competitive advantage to the Self-Build Team over other proposers responding to this RFP, as well as adherence to PPA terms and milestones required of all proposers and the SBO's proposed cost protection measures.

The cost recovery methods between a regulated utility SBO Proposal and IPP Proposals are fundamentally different due to the business environments they operate in. As a result, the Company has instituted a process to compare the two types of proposals for the initial evaluation of the price related criteria on a 'like' basis through comparative analysis.

At the core of an SBO Proposal are its total project capital cost and any associated annual operations and maintenance ("O&M") costs. During the RFP's initial pricing evaluation step, these capital costs¹⁰ and O&M costs will be used in a revenue requirement calculation to determine the estimated revenues needed from customers which would allow the Company to recover the total cost of the project. The SBO revenue requirements are then used in a levelized price calculation to determine a Levelized Energy Price ("LEP") (\$/MWh), if for energy needs, or to determine an Energy Storage Only Price (\$/MW), if for Fast Frequency Response needs. These price calculations will then be used for comparison to IPP Proposals.

The Company, in conjunction with the Independent Observer, may also conduct a risk assessment of the SBO Proposal to ensure an appropriate level of customer cost protection measures are included in such Proposal.

In response to the 18 MW Fast Frequency Response need, the Self-Build Team will only be permitted to submit a Proposal or group of Proposals (with up to a total of 4 variations for each Proposal) which collectively address this need, and no more. These Proposals are intended to serve as the Company's Parallel Plan, as described in the PUC's Framework for Competitive Bidding.¹¹ The Self-Build team will be allowed to submit one (1) additional Proposal (with up to a total of 4 variations) in response to the energy need.

The SBO will be permitted to submit a shared savings mechanism with its Proposal to share in any cost savings between the amount of cost bid in the SBO Proposal and the actual cost to construct the Project. If the SBO Proposal is selected to the Final Award Group, the proposed shared savings mechanism will need to be approved by the PUC. Submission of a shared savings mechanism is not required and will not be considered in the evaluation of the SBO Proposal.

¹⁰ Self-Build Proposals will be required to provide a table identifying project costs by year. These capital costs should be all inclusive, including but not limited to costs associated with equipment, Engineering, Procurement, and Construction ("EPC"), interconnection, overhead, and Allowance for Funds Used During Construction ("AFUDC").

¹¹ See Decision and Order No. 23121, filed December 8, 2006, in Docket No. 03-0372.

1.10 Dispute Resolution Process

- 1.10.1 If disputes arise under the RFP, the provisions of Section 1.10 and the dispute resolution process established in the Framework will control. See Part V of the Framework.
- 1.10.2 Proposers who challenge or contest any aspect of the RFP process must first attempt to resolve their concerns with the Company and the Independent Observer (“Initial Meeting”). The Independent Observer will seek to work cooperatively with the parties to resolve any disputes or pending issues and may offer to mediate the Initial Meeting to resolve disputes prior to such issues being presented to the PUC.
- 1.10.3 Any and all disputes arising out of or relating to the RFP which remain unresolved for a period of twenty (20) Days after the Initial Meeting takes place may, upon the agreement of the Proposer and the Company, be submitted to confidential Mediation in Honolulu, Hawai‘i, pursuant to and in accordance with the Mediation Rules, Procedures, and Protocols of Dispute Prevention Resolution, Inc. (“DPR”) (or its successor) or, in its absence, the American Arbitration Association then in effect (“Mediation”). The Mediation will be administered by DPR. If the parties agree to submit the dispute to Mediation, the Proposer and the Company shall each pay fifty percent (50%) of the cost of the Mediation (i.e., the fees and expenses charged by the mediator and DPR) and shall otherwise each bear their own Mediation costs and attorney’s fees.
- 1.10.4 If settlement of the dispute is not reached within sixty (60) Days after commencement of the Mediation, or if after the Initial Meeting, the parties do not agree to submit any unresolved disputes to Mediation, then as provided in the Framework, the Proposer may submit the dispute to the PUC in accordance with the Framework.
- 1.10.5 In accordance with the Framework, the PUC will serve as the arbiter of last resort for any disputes relating to this RFP involving Proposers. The PUC will use an informal expedited dispute resolution process to resolve the dispute within thirty (30) Days, as described in Parts III.B.8 and V of the Framework.¹² There will be no right to hearing or appeal from this informal expedited dispute resolution process.
- 1.10.6 If any Proposer initiates a dispute resolution process for any dispute or claim arising under or relating to this RFP, other than that permitted by the Framework and Section 1.10 (e.g., a court proceeding), then such Proposer shall be responsible for any and all attorneys’ fees and costs that may be incurred by the Company or the PUC in order to resolve such claim.

¹² The informal expedited dispute resolution process does not apply to PUC review of contracts that result from the RFP. See Decision and Order No. 23121 at 34-35. Further, the informal expedited dispute resolution process does not apply to the Framework’s process relating to issuance of a draft and final RFP, and/or to the PUC approval of the RFP because: (1) the Framework (and the RFP) set forth specific processes whereby interested parties may provide input through the submission of comments; and (2) the Framework’s dispute resolution process applies to “Bidders” and there are no “Bidders” at this stage in the RFP process.

1.11 No Protest or Appeal

Subject to Section 1.10, no Proposer or other person will have the right to protest or appeal any award of a Project made by the Company.

By submitting a Proposal in response to the RFP, the Proposer expressly agrees to the terms and conditions set forth in this RFP.

1.12 Modification or Cancellation of the Solicitation Process

- 1.12.1 Unless otherwise expressly prohibited, the Company may, at any time up to the final execution of an RDG PPA or ESPPA, as may be applicable, in consultation with the Independent Observer, postpone, withdraw and/or cancel any requirement, term or condition of this RFP, including deferral of the award or negotiation of any contract, and/or cancellation of the award all together, all of which will be without any liability to the Company.
- 1.12.2 The Company may modify this RFP subject to requirements of the Framework, whereby the modified RFP will be reviewed by the Independent Observer and submitted to the PUC thirty (30) Days prior to its issuance, unless the PUC directs otherwise. See Framework Part IV.B.10. The Company will follow the same procedure with regard to any potential postponement, withdrawal or cancellation of the RFP or any portion thereof.

Chapter 2: Resource Needs and Requirements

2.1 Performance Standards

Proposals must meet the attributes set forth in this RFP and the requirements of the RDG PPA for proposals that include a generation component or the ESPPA for standalone energy storage proposals. This RFP and the RDG PPA or ESPPA set forth the minimum requirements that all Proposals must satisfy to be eligible for consideration in this RFP. Additional Performance Standards may be required based on the results of the IRS.

Facilities must be able to operate in grid-forming mode when directed by the Company as defined in the RDG PPA or ESPPA.

Black start capability is preferred for standalone energy contingency reserve storage or energy storage paired with generation facilities. Proposals will need to identify¹³ any incremental costs to enable their facility to be black start capable, if not already enabled.

For standalone energy storage or energy storage paired with generation facilities, the functionality and characteristics of the storage must be maintained throughout the term of the PPA. To be clear Proposers may not propose any degradation for either capacity or efficiency in their Proposals.

¹³ If black start is not already enabled for the Proposal, any additional costs necessary to enable black start will be identified in the submission instructions defined in Appendix B.

2.2 Transmission System Information

- 2.2.1 Company information regarding an initial assessment of potential MW capacity of 69 kV transmission-level circuits providing possible points of interconnection has been developed for Sites included in the Land Request for Information (“Land RFI”) as described in Section 3.11 and will be made available to Proposers only after execution of the Stage 2 NDA.¹⁴ This initial assessment was performed using the assumption that both the PGV and Hu Honua facilities would be placed into service and the potential capacity information indicated may be different in the case that either or both of the PGV and Hu Honua facilities are not placed into service. Proposers should perform their own evaluation of project locations, and the Company does not guarantee any project output or ability to connect based on such information. Prior to submitting a proposal, Proposers are encouraged to inquire about the viability of interconnecting a proposed Project at a specific location. For example, a Project must interconnect through a minimum of two transmission lines and no single point of failure resulting in a loss of more than 30 MW; however depending on but not limited to, factors such as location of the Point of Interconnection, system load, generating unit dispatch, and transmission line contingencies, the Project may require more than two transmission line terminations. Please direct questions to the RFP Email Address in Section 1.6.
- 2.2.2 A detailed IRS, when performed, may reveal other adverse system impacts that may further limit a Project’s ability to interconnect and/or further limit the net output of the Facility without upgrades.

2.3 Interconnection to the Company System

- 2.3.1 The Interconnection Facilities includes both: (1) Seller-Owned Interconnection Facilities; and (2) Company-Owned Interconnection Facilities.
- 2.3.2 All Proposals must include a description of the Proposer’s plan to transmit power from the Facility to the Company System. The proposed Interconnection Facilities must be compatible with the Company System. In the design, Projects must adequately consider Company requirements to address impacts on the performance and reliability of the Company System.
- 2.3.2.1 In addition to the Performance Standards and findings of the IRS, the design of the Interconnection Facilities, including power rating, Point(s) of Interconnection with the Company System, and scheme of interconnection, must meet Company standards. The Company will provide its construction standards and procedures to the Proposer (Engineer, Procure, Construct Specifications for Hawaiian Electric Power Lines and Substations) if requested via the RFP Email Address in Section 1.6 and upon the execution of a Stage 2 NDA as specified in Section 3.12.1. These specifications are intended to illustrate the scope of work typically required to administer and perform the design and construction of a Hawai’i Electric Light substation and power line.

¹⁴ Appendix E contains the Mutual Confidentiality and Non-Disclosure Agreement for this RFP.

- 2.3.2.2 Interconnection Facilities must be designed such that, with the addition of the Facility, the Company System can meet all relevant Transmission Planning Criteria¹⁵ and any amendments thereto considering the Allowed Capacity and any Contingency Storage.
- 2.3.3 Tariff Rule No. 19, a copy of which is attached as Appendix I, establishes provisions for Interconnection and Transmission Upgrades. The tariff provisions are intended to simplify the rules regarding who pays for, installs, owns, and operates interconnection facilities in the context of competitive bidding. Proposers will be required to build the Company-Owned Interconnection Facilities, including the switching station and line work, except for any work in the Company's existing energized facilities and the final tap. Construction of Company-Owned Interconnection Facilities by the Proposer must comply with industry standards, laws, rules and licensing requirements, as well as the Company's specific construction standards and procedures that the Company will provide upon request. (See Section 2.3.1.) The Company uses the breaker-and-a-half scheme for its transmission switching station as shown in Attachment A of Appendix I – Rule 19 Tariff. Proposers should follow this scheme for purposes of their estimates.
- 2.3.4 The Proposer shall be responsible for all costs required to interconnect a Project to the Company System, including all Seller-Owned Interconnection Facilities and Company-Owned Interconnection Facilities.
- 2.3.5 Proposers are required to include in their pricing proposal all costs for interconnection and transmission equipment expected to be required between their Facility and their proposed Point of Interconnection. Appendix H includes information related to Company-Owned Interconnection Facilities and costs that may be helpful to Proposers.
- Selected Proposers shall be responsible for the actual final costs of all Seller-Owned Interconnection Facilities and Company-Owned Interconnection Facilities, whether or not such costs exceed the costs set forth in a Proposer's Proposal. No adjustments will be allowed to the proposed price in a Proposal if actual costs for Interconnection Facilities exceed the amounts proposed.
- 2.3.6 Proposers are required to include in their pricing proposal all costs for distribution-level service interconnection for station power.
- 2.3.7 All Projects will be screened for general readiness to comply with the requirements for interconnection. Proposals selected to the Final Award Group will be subject to further study in the form of an IRS. The IRS process is further described in Section 5.1. The results of the completed IRS, as well as any mitigation measures identified, will be incorporated into the terms and conditions of a final executed PPA.

¹⁵ Transmission Planning Criteria are further described in the PSIP beginning on page O-11 of Appendix O.

Chapter 3: Instructions to Proposers

3.1 Schedule for the Proposal Process

Table 1 sets forth the proposed schedule for the proposal process (the “RFP Schedule”). The RFP Schedule is subject to PUC approval. The Company reserves the right to revise the RFP Schedule as necessary. Changes to the RFP Schedule prior to the RFP Proposal Due Date will be posted to the RFP website. Changes to the RFP Schedule after the Proposal Due Date will be communicated via Email or via the Electronic Procurement Platform to the Proposers.

**Table 1
Proposed RFP Schedule**

Milestone	Schedule Dates
(1) Status Conference held	February 7, 2019
(2) Draft RFP filed	April 1, 2019
(3) Status Conferences held	April 18, 2019 May 2, 2019
(4) Commission solicited Stakeholder and Company Comments by	May 20, 2019
(5) Proposed Final RFP filed	July 10, 2019
(6) Final RFP is Issued	August 22, 2019
(7) Self-Build or Affiliate Proposal Due Date	November 4, 2019 at 2:00 pm HST ¹⁶
(8) IPP Proposal Due Date	November 5, 2019 at 2:00 pm HST
(9) Selection of Priority List	January 17, 2020
(10) BAFOs Due	January 24, 2020
(11) Selection of Final Award Group	May 8, 2020
(12) Contract Negotiations Start	May 15, 2020

3.2 Company RFP Website/Electronic Procurement Platform

3.2.1 The Company has established a website for general information to share with potential Proposers. The RFP website is located at the following link:

www.hawaiielectriclight.com/competitivebidding

The Company will provide general notices, updates, schedules and other information on the RFP website throughout the process. Proposers should check the website frequently to stay abreast of any new developments. This website will also contain the link to the Electronic Procurement Platform employed by the Company for the receipt of Proposals.

¹⁶ An SBO or Affiliate Proposal must also be filed in hard copy form with the PUC a minimum of one (1) Day before other Proposals are due.

“Sourcing Intelligence” developed by Power Advocate is the Electronic Procurement Platform that the Company has licensed and will utilize for this RFP. Proposers who do not already have an existing account with PowerAdvocate and who intend to submit a Proposal for this RFP will need to register as a “Supplier” with PowerAdvocate.

- 3.2.2 There are no license fees, costs, or usage fees to Proposers for the use of the Electronic Procurement Platform.

See [Appendix D](#) for user information on and screenshots of PowerAdvocate’s Sourcing Intelligence procurement platform.

3.3 Information Conferences

The Commission held three status conferences on February 7, 2019, April 18, 2019, and May 2, 2019 to allow the Companies to propose plans for their Stage 2 RFPs and to respond to questions from the Commission, the Consumer Advocate and stakeholders. The Companies’ presentations were made available on the Companies’ RFP Website. The Commission also solicited comments from stakeholders on the Companies’ Stage 2 Draft RFPs on May 6, 2019 before releasing its Order No. 36356 providing guidance on the draft RFPs for dispatchable and renewable generation on June 10, 2019. On July 5, 2019, the Commission issued Order No. 36406 providing further clarification of Order No. 36356.

Prospective Proposers may continue submitting written questions regarding the RFP to the RFP Email Address set forth in [Section 1.6](#). The Company will endeavor to address all questions that will be helpful to prospective Proposers via a Q&A section on the RFP website.

Prospective Proposers should review the RFP Website’s Q&A section prior to submission of their Proposal. Duplicate questions will not be answered.

3.4 Preparation of Proposals

- 3.4.1 Each Proposer shall be solely responsible for reviewing the RFP (including all attachments and links) and for thoroughly investigating and informing itself with respect to all matters pertinent to this RFP, the Proposer’s Proposal, and the Proposer’s anticipated performance under the RDG PPA or ESPPA. It is the Proposer’s responsibility to ensure it understands all requirements of the RFP, to seek clarification if the RFP’s requirements or Company’s request is not clear, and to ask for any confirmation of receipt of submission of information. Under Section 1.7.4, the Proposer is solely responsible for all errors in its Proposal(s). The Company will not accept any explanation by a Proposer that it was incumbent on the Company to catch any error.
- 3.4.2 Proposers shall rely only on official information provided by the Company in this RFP when preparing their Proposal. The Company will rely only on the information included in the Proposals and additional information solicited by the Company to Proposers in the format requested, to evaluate the Proposals received. Evaluation will be based on the stated information in this RFP and on information submitted by Proposers in response to

this RFP. Proposal submissions should not reference previous RFP submissions for support. Proposers also should not assume that any previous RFP decisions/preferences will also pertain to this RFP.

- 3.4.3 Each Proposer shall be solely responsible for, and shall bear all of its costs incurred in the preparation of its Proposal and/or its participation in this RFP, including, but not limited to, all costs incurred with respect to the following: (1) review of the RFP documents; (2) meetings with the Company; (3) Site visits; (4) third-party consultant consultation; and (5) investigation and research relating to its Proposal and this RFP. The Company will not reimburse any Proposer for any such costs, including the selected Proposer(s).
- 3.4.4 Each Proposal must contain the full name and business address of the Proposer and must be signed by an authorized officer or agent¹⁷ of the Proposer.

3.5 Organization of the Proposal

The Proposal must be organized as specified in Appendix B. It is the Proposer's responsibility to ensure the information requested in this RFP is submitted and contained within the defined Proposal sections as specified in Appendix B.

3.6 Proposal Limitations

Proposers expressly acknowledge that Proposals are submitted subject to the following limitations:

The RFP does not commit or require the Company to award a contract, pay any costs incurred by a Proposer in the preparation of a Proposal, or procure or contract for products or services of any kind whatsoever. The Company reserves the right, in consultation with the Independent Observer, to accept or reject, in whole or in part, any or all Proposals submitted in response to this RFP, to negotiate with any or all Proposers eligible to be selected for award, or to withdraw or modify this RFP in whole or in part at any time.

- The Company reserves the right, in consultation with the Independent Observer, to request additional information from any or all Proposers relating to their Proposals or to request that Proposers clarify the contents of their Proposals. Proposers who are not responsive to such information requests may be eliminated from further consideration upon consultation with the Independent Observer.
- The Company reserves the right, in consultation with the Independent Observer, to solicit additional Proposals from Proposers after reviewing the initial Proposals.

¹⁷ Proposer's officer or agent must be authorized to sign the Proposal. Such authorization must be in writing and may be granted via Proposer's organizational documents (i.e., Articles of Incorporation, Articles of Organization, By-laws, etc.), resolution, or similar documentation.

Other than as provided in this RFP, no Proposer will be allowed to alter its Proposal or add new information to a Proposal after the Proposal Due Date.

- All material submitted in response to this RFP will become the sole property of the Company, subject to the terms of the Stage 2 NDA.

3.7 Proposal Compliance and Bases for Disqualification

Proposers may be deemed non-responsive and/or Proposals may not be considered for reasons including, but not limited to, the following:

- Any unsolicited contact by a Proposer or prospective Proposer with personnel of the Company pertaining to this RFP as described in Section 1.5.5.
- Any illegal or undue attempts by or on behalf of the Proposer or others to influence the Proposal Review process.
- The Proposal does not meet one or more of the Eligibility Requirements specified in Section 4.2.
- The Proposal does not meet one or more of the Threshold Requirements specified in Section 4.3.
- The Proposal is deemed to be unacceptable through a fatal flaws analysis as described in Section 4.4.2.
- The Proposer does not respond to a Company request for additional information to clarify the contents of its Proposal within the timelines specified by the Company.
- The Proposal contains misrepresentations or errors.

3.8 Power Purchase Agreement

- 3.8.1 The Power Purchase Agreement for proposals selected under this RFP that include a generation component will be in the form of the RDG PPA, attached as Appendix J and Appendix L.
- 3.8.2 The Power Purchase Agreement for standalone energy storage proposals selected under this RFP will be in the form of the Company's ESPPA, attached as Appendix K.
- 3.8.3 If selected, any Affiliate Proposers will be required to enter into the RDG PPA or ESPPA with the Company.
- 3.8.4 If selected, a Self-Build Proposer will not be required to enter into a PPA or ESPPA with the Company. However, the Self-Build Proposer will be held to the proposed modifications to the RDG PPA and/or ESPPA, if any, it submits as part of the SBO in accordance with Section 3.8.7. Moreover, the SBO will be held to the same performance

metrics and milestones set forth in the RDG PPA and/or ESPPA to the same extent as all Proposers, as attested to in the SBO's Appendix G, Attachment 1, Self Build Option Certification submittal. If liquidated damages are assessed, they will be paid from shareholder funds and returned to customers through the Purchased Power Adjustment Clause ("PPAC") or other appropriate rate adjustment mechanisms.

To retain the benefits of operational flexibility for a Company-owned facility, the SBO will be permitted to adjust operational requirements and performance metrics with the approval of the PUC. The process for adjustment would be similar to a negotiated amendment to a PPA with PUC approval.

- 3.8.5 In general, under the RDG PPA, payment to the Seller contains two parts: a Lump Sum Payment component to cover the fixed costs of the Project and a Price for Purchase of Electric Energy component (\$/MWh component) to cover variable operations and maintenance costs (if applicable, depending on the resource). In return, the Seller shall guarantee minimum performance and availability metrics to ensure that the Facility is maintained and available for energy storage (if applicable) and dispatch, as well as provide an indication of the available energy in near real-time for the Company's dispatch. Company shall not be obligated to accept nor shall it be required to pay for test energy generated by the Facility during acceptance testing or other test conditions.
- 3.8.6 In general, under the ESPPA, payment to the Seller consists of a Lump Sum Payment to cover dispatchability and availability of the Facility. In return, the Seller shall guarantee minimum performance and availability metrics to ensure that the Facility is maintained and available for energy storage and dispatch, as well as provide an indication of the available energy in near real-time for the Company's dispatch.
- 3.8.7 As described in Section 2.1, the Performance Standards identified in the applicable RDG PPAs or the ESPPA establish the minimum requirements a Proposal must satisfy to be eligible for consideration in this RFP. A proposed Facility's ability to meet these Performance Standards is both a Threshold Requirement and a Non-Price Related Criteria under Sections 4.3 and 4.4.2, respectively. As such, the Performance Standards included in the RDG PPAs or ESPPA are non-negotiable by a Self-Build Proposer or any other Proposer. Proposers may propose modifications to other sections of the RDG PPA or ESPPA but are encouraged to accept such terms as written in order to expedite the overall RFP process and potential contract negotiations. As a component of their respective Proposals, a Self-Build Proposer or any other Proposers who elect to propose modifications shall provide a Microsoft Word red-line version of the relevant document identifying specific proposed modifications to the model language that the Proposer is agreeable to, as well as a detailed explanation and supporting rationale for each modification.
- 3.8.7.1 General comments, drafting notes and footnotes such as "parties to discuss" are unacceptable and will be considered non-responsive. Proposed modifications to the RDG PPA and ESPPA will be evaluated as a non-price evaluation criterion as further described in Section 4.4.2. In order to facilitate this process, the Company will make available electronic versions of the model agreements on the RFP website and through the

PowerAdvocate platform for the RFP. Any proposed modifications to the RDG PPA or ESPPA will be subject to negotiation between the Company and the Final Award Group. As stated above, since general comments, drafting notes, and footnotes without accompanying specific proposed language modifications are unacceptable and non-responsive, the Company will not negotiate provisions simply marked by such general comments, drafting notes and footnotes.

3.8.7.2 The Company has an interest in maintaining consistency for certain provisions of the RDG PPAs and ESPPA, such as the calculation of availability and payment terms. Therefore, for such provisions, the Company will endeavor to negotiate similar and consistent language across PPAs for the Final Award Group.

3.8.8 Proposals that do not include specific proposed modifications to the attached RDG PPAs or ESPPA will be deemed to have accepted the RDG PPA or ESPPA in its entirety.

3.9 Pricing Requirements

3.9.1 Proposers must submit pricing for each of their variations associated with each Proposal (if variations as described in Section 1.8.2 and 1.8.3 are submitted). Proposers are responsible for understanding the terms of the RDG PPA or ESPPA. Pricing cannot be specified as contingent upon other factors (e.g., changes to federal tax policy or receiving all Investment Tax Credits assumed).

3.9.2 Escalation in pricing over the term of the RDG PPA or the term of the ESPPA is prohibited.

3.9.3 Pricing information must only be identified within specified sections of the Proposal instructed by this RFP's Appendix B Proposer's Response Package (i.e., Proposal pricing information must be contained within defined Proposal sections of the Proposal submission). Pricing information contained anywhere else in a Proposal will not be considered during the evaluation process.

3.9.4 For projects that include a generation component, the Proposer's Response Package must include the following prices for each Proposal (and variation):

For IPP or Affiliate proposals:

- **Lump Sum Payment (\$/year):** Payment amount for full dispatchability of the Facility. Payment will be made in monthly increments.
- **Price for Purchase of Electric Energy (\$/MWh):** Payment for delivery of net energy sourced from the variable generation resource, if applicable. No Energy Payment will be provided for any energy delivery that is sourced originally from the grid (Company's System).

- **Black Start (\$):** For energy storage paired with generation facilities, if the Facility is not already black start enabled, the incremental cost required to enable black start.
- **Contingency Storage (\$/year):** For generation facilities that include Contingency Storage, the portion of the Lump Sum Payment attributable to the Contingency Storage.

For Self-Build Proposals:

- **Total Project Capital Costs (\$/year):** Total capital costs for the project (identified by year).
- **Annual O&M Costs (\$/year):** Initial year operations and maintenance costs, annual escalation rate.
- **Annual Revenue Requirement (\$/year):** Annual revenue requirements (ARR) calculated for each year.
- **Black Start (\$):** For energy storage paired with generation facilities, if the Facility is not already black start enabled, the incremental cost required to enable black start.
- **Contingency Storage (\$/year):** For generation facilities that include Contingency Storage, the share of the Total Project Capital Costs, Annual O&M Costs, and Annual Revenue Requirement to provide Contingency Storage.

See [Appendix G](#) for descriptions and detail on the Total Project Capital Costs, Annual O&M Costs and Annual Revenue Requirement for the Self-Build Proposals.

3.9.5 For standalone energy storage projects, the Proposer's Response Package must include the following prices for each Proposal (and variation):

For IPP or Affiliate proposals:

- **Lump Sum Payment (\$/year):** Payment amount assuming full availability and dispatchability. Payment will be made in monthly increments.
- **Black Start (\$):** For energy storage coupled with generation facilities, if the Facility is not already black start enabled, the incremental cost required to enable black start.

For Self-Build Proposals:

- **Total Project Capital Costs (\$/year):** Total capital costs for the project (identified by year).
- **Annual O&M Costs (\$/year):** Initial year operations and maintenance costs, annual escalation rate.
- **Annual Revenue Requirement (\$/year):** Annual revenue requirements (ARR) calculated for each year.
- **Black Start (\$):** For energy storage paired with generation facilities, if the Facility is not already black start enabled, the incremental cost required to enable black start.

See [Appendix G](#) for descriptions and detail on the Total Project Capital Costs, Annual O&M Costs and Annual Revenue Requirement for the Self-Build Proposals.

- 3.9.6 As identified in the Schedule of Defined Terms in the PPA under “BESS Allocated Portion of the Lump Sum Payment”, the allocated portion of the Lump Sum Payment specified for energy storage for the Facility is 50% and shall be a non-negotiable percentage in the PPA.

3.10 Project Description

- 3.10.1 Proposals that include a generation component are required to provide a **NEP RFP Projection** for the Project. The NEP RFP Projection associated with the proposed Project represents the estimated annual net energy (in MWh) that could be produced by the Facility and delivered to the Point of Interconnection over a ten-year period with a probability of exceedance of 95%. If the proposed Project includes an energy storage component, it should not be factored into the NEP RFP Projection. Any losses that may be incurred from energy being stored and then discharged from the energy storage component or any energy that may be diverted to the energy storage component due to generation in excess of the Facility’s Allowed Capacity should not be factored into the NEP RFP Projection. The NEP RFP Projection should assume that all energy is being directly exported to the Hawaii Electric Light System. The NEP RFP Projection will be used in the RFP evaluation process and therefore Proposers will be held to their provided value.¹⁸

- 3.10.2 Proposers must provide all information pertaining to the design, development, and construction of the Interconnection Facilities as specified in [Appendix B](#).

¹⁸ If a Proposal is selected to the Final Award Group and a PPA is executed between the Company and the Proposer, the NEP RFP Projection will be further evaluated at several steps throughout the process as set forth in the RDG PPA, and adjustments to the Lump Sum Payment will be made accordingly. Additionally, because the Company will rely on an accurate representation of the NEP RFP Projection in the RFP evaluation, a one-time liquidated damage as described in the RDG PPA will be assessed if the First NEP benchmark is less than the Proposer’s NEP RFP Projection. After the Facility has achieved commercial operations, the performance of the Facility will be assessed on a continuing basis against key metrics identified in the RDG PPA. See [Article 2](#) and [Attachment U](#) of the RDG PPA.

- 3.10.3 Each Proposer must also agree to provide Project financial information, including proposed Project finance structure information specified in Appendix B. Such information will be used to evaluate Threshold Requirements and non-price criteria (e.g., Financial Viability of Proposer, Financial Strength and Financing Plan, State of Project Development and Schedule) set forth in Sections 4.3 and 4.4.2. Upon selection, the Final Award Group may be requested to provide further detailed cost information if requested by the PUC or the Consumer Advocate as part of the PPA approval process. If requested, such information would be provided to the PUC, Consumer Advocate and Company pursuant to a protective order in the docket.
- 3.10.4 The Proposer agrees that no material changes or additions to the Facility from what is submitted in its Proposal will be made without the Proposer first having obtained prior written consent from the Company. Evaluation of all Proposals in this RFP is based on the information submitted in each Proposal at the Proposal Due Date. If any Proposer requests any Proposal information to be changed after that date, the Company, in consultation with the Independent Observer, and in consideration of whether the evaluation is affected, will determine whether the change is permitted.

3.11 Sites Identified by the Company

- 3.11.1 As an alternative to a Site identified by the Proposer, the Company has identified potential Sites where landowners have expressed a willingness to negotiate a lease or purchase of the land to support a renewable energy project. These Sites were identified through a Land RFI. Proposers will be responsible for working directly with the land owner and must secure Site Control with such land owner prior to submitting a Proposal. Land RFI information is available to interested parties who sign the Stage 2 NDA. The Land RFI is further described in Appendix F.

Proposers are not required to select a Site identified in the Land RFI and as noted above may propose any Site for a Project. A Proposer may ask the Company questions as set forth in Section 2.2.1 if it would like to obtain similar information about the viability of interconnection at its proposed Site as identified for the Land RFI parcels.

- 3.11.2 Additionally, two Company-owned Sites are being offered to Proposers of standalone energy storage Projects for their consideration. An area within the Keahole Generating Station, referred to as the Keahole Site, and an area within the Puna Generating Station, referred to as the Puna Site, are further described in Appendix F.

Proposers proposing to use either the Keahole or Puna Sites shall be required to agree to conditions for such use as provided for in an attachment to the PPA. Provisions providing for access to the Sites during construction and thereafter, during commercial operations, will be subject to current Company security policies and procedures. Physical, communication and internet security will be required consistent with Company policy. Additional measures may be required to limit/eliminate interference between Seller and Company facilities and infrastructure. Such policies, procedures and requirements may change as necessary during the term of the ESPPA to reflect changes in Company policies or to remain in compliance with current applicable laws, rules or

regulations. A draft copy of the proposed form of the Terms and Conditions for Use (“TCU”) is included as Attachment X to the model ESPPA. Limited sections (Section 4 Seller’s Investigation of the Company-Owned Site, Section 5 Construction and Maintenance, Section 7 Hazardous Substances, and Section 8 Archeological and Historic Items) of the TCU shall be negotiable.

The Company provided potential Proposers an opportunity to visit both sites on August 7, 2019. Information from the site visits will be posted on the Company’s RFP website.

3.12 Confidentiality

- 3.12.1 Each prospective Proposer must submit an executed Stage 2 NDA (specific to the Hawai‘i Variable Renewable Dispatchable Generation and Energy Storage RFP) in the form attached as Appendix E by the Proposal Due Date specified in the RFP Schedule in Section 3.1. The form of the Stage 2 NDA is not negotiable. Information designated as confidential by the Company will be provided on a limited basis, and only those prospective Proposers who have submitted an executed Stage 2 NDA will be considered. NDAs that were fully executed for Stage 1 will not be accepted for Stage 2. Proposers must clearly identify all confidential information in their Proposals. However, Proposers should designate as confidential only those portions of their Proposals that genuinely warrant confidential treatment. The Company discourages the practice of marking every page of a Proposal as confidential. The Company will make reasonable efforts to protect any such information that is clearly marked as confidential. Consistent with the terms of the Stage 2 NDA, the Company reserves the right to share any information, even if marked confidential, to its agents, contractors, or the Independent Observer for the purpose of evaluating the Proposal and facilitating potential contract negotiations.
- 3.12.2 Proposers, in submitting any Proposal(s) to Company in response to this RFP, certify that such Proposer has not shared its Proposal(s), or any part thereof, with any other Proposer of a Proposal(s) responsive to this RFP.
- 3.12.3 The Company will request that the PUC issue a Protective Order to protect confidential information provided by Proposers to the Company and to be filed in a proceeding before the PUC. A copy of the Protective Order, once issued by the PUC, will be provided to Proposers. Proposers should be aware that the Company may be required to share certain confidential information contained in Proposals with the PUC, the State of Hawai‘i Department of Commerce and Consumer Affairs, Division of Consumer Advocacy, and the parties to any docket instituted by the PUC, provided that recipients of confidential information have first agreed in writing to abide by the terms of the Protective Order. Notwithstanding the foregoing, no Proposer will be provided with Proposals from any other Proposer, nor will Proposers be provided with any other information contained in such Proposals or provided by or with respect to any other Proposer.

3.13 Credit Requirements Under the PPA

- 3.13.1 Proposers with whom the Company concludes PPA contract negotiations must post Development Period Security and Operating Period Security in the form of an irrevocable standby letter of credit from a bank chartered in the United States as required and set forth in Article 14 of the RDG PPA or the ESPPA.
- 3.13.2 The Development Period Security and Operating Period Security identified in the RDG PPAs or the ESPPA are minimum requirements. Proposers shall not propose an amount lower than that set forth in the RDG PPAs or the ESPPA.
- 3.13.3 Each Proposer shall be required to provide a satisfactory irrevocable standby letter of credit in favor of the Company from a bank chartered in the United States to guarantee Proposer's payment of interconnection costs for all Company-Owned Interconnection Facilities in excess of the Total Estimated Interconnection Costs and/or all relocations costs in excess of Total Estimated Relocation Costs that are payable to Company as required and set forth in Attachment G to the RDG PPAs or the ESPPA.
- 3.13.4 Proposers may be required to provide an irrevocable standby letter of credit in favor of the Company from a bank chartered in the United States in lieu of the required Source Code Escrow in an amount and as required and set forth in Attachment B to the RDG PPAs or ESPPA.

Chapter 4: Evaluation Process and Evaluation Criteria

4.1 Proposal Evaluation and Selection Process

The Company will employ a multi-step evaluation process. Once the Proposals are received, the Proposals will be subject to a consistent and defined review, evaluation, and selection process. This Chapter provides a description of each step of the process, along with the requirements of Proposers at each step. Figure 1 and Figure 2 set forth the flowchart for the proposal evaluation and selection process.

Upon receipt of the Proposals, the Company will ensure that the Proposals meet the Eligibility Requirements, and if so, will review the Proposals to ensure that the Threshold Requirements have been met. The Company, in coordination with the Independent Observer will determine if a Proposer is allowed to cure any aspect of its Proposal or whether the Proposal would be eliminated based on failure to meet either Eligibility or Threshold Requirements.¹⁹ If a Proposer is provided the opportunity to cure any aspect of its Proposal, the Proposer shall be given three (3) business Days to cure from the date of notification to cure. Proposals that have successfully met the Eligibility and Threshold

¹⁹ As a general rule, if a Proposer does not include a requested document, inadvertently excludes minor information or provides inconsistencies in its information, it may be given a chance to cure such deficiency. If a Proposer fails to provide material required information in its Proposal and providing the Proposer an opportunity to cure is deemed by the Company, in consultation with the Independent Observer, as an unfair advantage to such Proposer, the Proposal could be classified as non-conforming and eliminated for failure to meet the Eligibility Requirements.

Requirements will then enter a two-phase process for Proposal evaluation, which includes the Initial Evaluation resulting in the development of a Priority List, followed by the opportunity for Priority List Proposals to provide Best and Final Offers, and then a Detailed Evaluation process to arrive at a Final Award Group.

Figure 1 – Evaluation Workflow

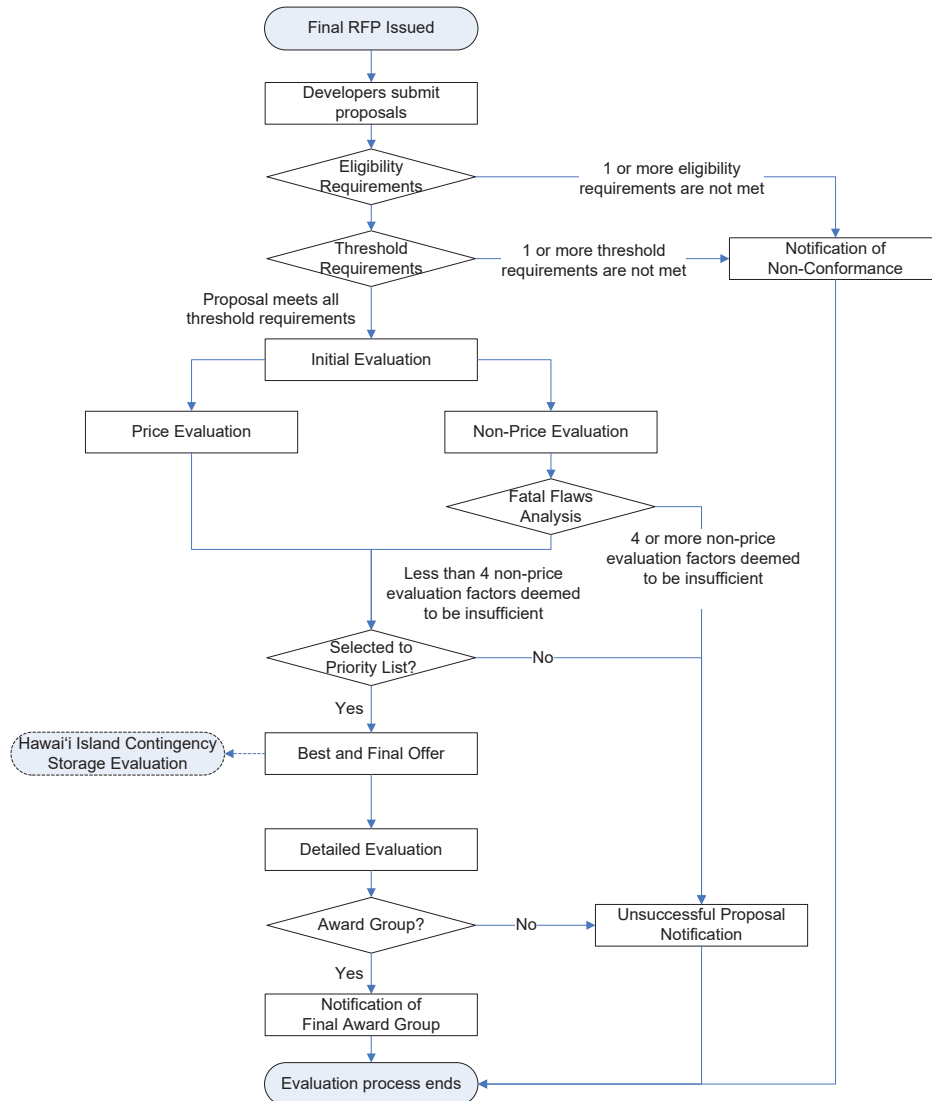
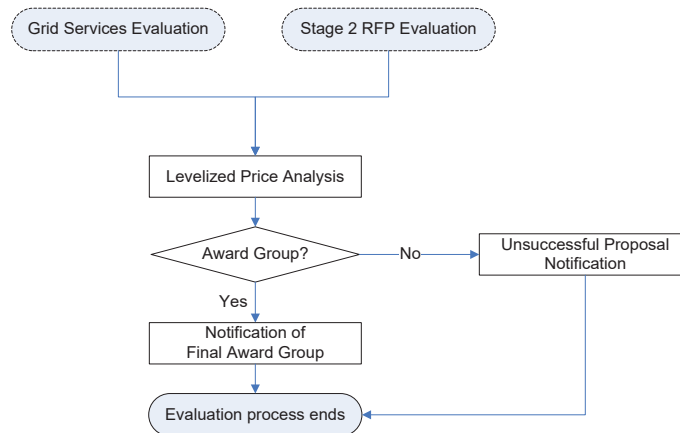

Figure 2 – Hawai‘i Island Contingency Storage Evaluation Workflow



4.2 Eligibility Requirements Assessment

Upon receipt of the Proposals, each Proposal will be reviewed to ensure that it meets the following Eligibility Requirements.

- The Proposal including required uploaded files must be received on time via the PowerAdvocate Platform.
- The Proposal Fee must be received on or before the Proposal Due Date.²⁰
- The Proposal must not contain material omissions.
- The Proposal must be signed and certified by an officer or other authorized person of the Proposer.
- The Proposer must fully execute the agreements or other documents required pursuant to this RFP.
- The Proposer must provide a certificate of good standing from the State of Hawai‘i Department of Commerce and Consumer Affairs.
- The Proposer must provide federal and state tax clearance certificates for the Proposer.
- The Proposal must not be contingent upon changes to existing county, state, or federal laws or regulations.
- The proposed Project must be located on the island of Hawai‘i.
- Project must be greater than the threshold for a waiver from the Competitive Bidding Framework applicable to Hawai‘i island.
- No single point of failure from the Facility shall result in a decrease in net electrical output greater than 30 MW.
- Project infrastructure and point of interconnection must be located outside the 3.2 foot sea level rise exposure area (SLR-XA) as described in the Hawai‘i Sea Level Rise Vulnerability and Adaptation Report (2017), and not located within a Tsunami Evacuation Zone.
- Proposals must meet the grid-charging requirements of Section 1.2.16.

²⁰ Proposal Fees will not be required for SBO Proposals or Proposals utilizing Company offered and owned sites.

- Standalone energy proposals must specify a GCOD no later than December 31, 2022.
- Generation only Proposals or generation paired with energy storage Proposals must specify a GCOD no later than December 31, 2025.

4.3 Threshold Requirement Assessment

Proposals that meet all the Eligibility Requirements will then be evaluated to determine compliance with the Threshold Requirements, which have been designed to screen out Proposals that are insufficiently developed, lack demonstrated technology, or will impose unacceptable execution risk for the Company. Proposers are responsible to provide explanations and supporting information demonstrating how and why they believe the Project they are proposing meets each of the Threshold Requirements. Proposals that fail to provide this information or meet a Threshold Requirement will be eliminated from further consideration upon concurrence with the Independent Observer. The Threshold Requirements for this RFP are the following:

- **Site Control:** The Proposal must demonstrate that the Proposer has Site Control for all real property required for the successful implementation of a specific Proposal at a Site not controlled by the Company, including any Interconnection Facilities for which the Proposer is responsible. The need for a firm commitment is necessary to ensure that Proposals are indeed realistic and can be relied upon as the Company moves through the remainder of the RFP process. In addition, developmental requirements and restrictions such as zoning of the Site and the status of easements must be identified and will be considered in determining whether the Proposal meets the Site Control threshold.

To meet this Site Control requirement, Proposers must do one of the following:

- Provide documentation confirming (1) that the Proposer has an existing legally enforceable right to use and control the Site, either in fee simple or under leasehold for a term at least equal to the term of the PPA or ESPPA (“Site Control”) as specified in the Proposer’s Proposal (taking into account the timelines set forth in this RFP for selection, negotiation, and execution of a PPA or ESPPA and PUC approval), and (2) the applicable zoning for the Site and that such zoning does not prohibit the development of the Site consistent with the Proposal; or
- Provide documentation confirming, at a minimum, (1) that the Proposer has an executed binding letter of intent, memorandum of understanding, option agreement, or similar document, with the land owner (a “binding commitment”) which sets forth the general terms of a transaction that would grant the Proposer the required Site Control, and (2) the applicable zoning for the Site and that such zoning does not prohibit the development of the Site consistent with the Proposal. The binding commitment does not need to be exclusive to the Proposer at the time the Proposal is submitted and may be contingent upon selection of the Proposal to the Final Award Group. If multiple Projects are provided a binding commitment for the same Site, the

documents granting the binding commitments must not prevent the Company from choosing the Proposal that otherwise would have been selected.

- **Government/Public Lands Only:** The above two bullet points may not be feasible where government or publicly-owned lands are part of the Site or are required for the successful implementation of the Proposal. In such a case, at a minimum the Proposer must provide a credible and viable plan, including evidence of any steps taken to date, to secure all necessary Site Control for the Proposal, including but not limited to evidence of sufficient progress toward approval by the government agency or other body vested with the authority to grant such approval (as demonstrated by records of the agency). The Proposer will be required, however, to demonstrate Site Control as required in the applicable RDG PPA or ESPPA should the Proposal be selected to the Final Award Group.
- **Performance Standards:** The proposed Facility must be able to meet the performance attributes identified in this RFP and the Performance Standards identified in the applicable RDG PPAs or the ESPPA. Proposals should include sufficient documentation to support the stated claim that the Facility will be able to meet the Performance Standards (including the Project's ability to provide Fast Frequency Response if the Proposal includes a Contingency Storage component or is for standalone contingency reserve storage). The Proposal should include information required to make such a determination in an organized manner to ensure this evaluation can be completed within the evaluation review period.
- **Proven Technology:** This criterion is intended as a check to ensure that the technology proposed is viable and can reasonably be relied upon to meet the objectives of this RFP. The Company will only consider Proposals utilizing technologies that have successfully reached commercial operations in commercial applications (i.e., a PPA) at the scale being proposed. Proposals should include any supporting information for the Company to assess the commercial and financial maturity of the technology being proposed.
- **Experience of the Proposer:** The Proposer, its affiliated companies, partners, and/or contractors and consultants on the Proposer's Project team must have experience in financing, designing, constructing, interconnecting, owning, operating, and maintaining at least one (1) electricity generation project, including all components of the project (i.e., storage or other attributes), similar in size, scope, technology, and structure to the Project being proposed by Proposer. The Company will consider a Proposer to have reasonably met this Threshold Requirement if the Proposer can provide sufficient information in its Proposal's RFP Appendix B Section 2.13 tables demonstrating that at least one member of the Proposer's team (identified in the Proposal) has specific experience in each of the following categories: financing, designing, constructing, interconnecting, owning, operating, and maintaining projects similar to the Project being proposed.

- **Credit/Collateral Requirements:** Proposers shall agree to post Development Period Security and Operating Period Security as described in Section 3.13.
- **Available Circuit Capacity:** The output capacity of the proposed Project (including Contingency Storage, as applicable) must not exceed the available capacity of the 69 kV circuit to which it will interconnect.
- **Viability of Proposer’s Financial Plan:** Proposers must provide a basic financial plan for the Project with details on the sources of debt and equity, capital structure, etc. Evidence must be provided of general support for Project financing.
- **Financial Compliance:** The proposed Project must not cause the Company to be subject to consolidation as set forth, in Financial Accounting Standards Board (“FASB”) Accounting Standards Codification Topic 810, Consolidation (“ASC 810”) as issued and amended from time to time by FASB. Proposers are required to state to the best of their knowledge, with supporting information to allow the Company to verify such conclusion, that the Proposal will not result in the Seller under the PPA being a Variable Interest Entity (“VIE”) and result in the Company being the primary beneficiary of the Seller that would trigger consolidation of the Seller’s finances on to the Company’s financial statements under FASB ASC 810. The Company will perform a preliminary consolidation assessment based on the Proposals received. The Company reserves the right to allow a Proposal to proceed through the evaluation process through selection of the Priority List and work with the Proposer on this issue prior to or during PPA negotiations.
- **Community Outreach:** Gaining community support is an important part of a Project’s viability and success. A comprehensive community outreach and communications plan (“Community Outreach Plan”) is an essential roadmap that guides a developer as they work with various communities and stakeholders to gain their support for a Project. Proposers must include a Community Outreach Plan that describes the Proposer’s commitment to work with the neighboring community and stakeholders and to provide them timely Project information during all phases of the Project. The Community Outreach Plan shall include but not be limited to the following information: Project description, community scoping (including stakeholder and community concerns), Project benefits, government approvals, development process (including Project schedule), and a comprehensive communications plan.

Proposers need to also be mindful of the Projects’ potential impacts to historical and cultural resources. At a minimum, Proposers should identify: (1) any valued cultural, historical, or natural resources in the area in question, including the extent to which traditional and customary native Hawaiian rights are exercised in the area; (2) the extent to which those resources – including traditional and customary native Hawaiian rights – will be affected or impaired by the proposed action; and (3) the feasible action, if any, to be taken to reasonably protect native Hawaiian rights if they are found to exist. Also, at a minimum, Proposers should have already contracted with a consultant with expertise in this field to begin a cultural impact assessment for the Project.

4.4 Initial Evaluation – Price and Non-Price Analysis

Proposals that meet both the Eligibility and Threshold Requirements are Eligible Proposals which will then be subject to a price and non-price assessment. Two teams have been established to undertake the Proposal evaluation process: a Price Evaluation Team and Non-Price Evaluation Team. The results of the price and non-price analysis will be a relative ranking and scoring of all Eligible Proposals. Price-related criteria will account for sixty percent (60%) of the total score and non-price-related criteria will account for forty percent (40%) of the total score. The non-price criteria and methodology for applying the criteria are explained in Section 4.4.2.

The Company will employ a closed-bidding process for this solicitation in accordance with Part IV.H.3 of the Framework where the price and non-price evaluation models to be used will not be provided to Proposers. However, the Company will provide the Independent Observer with all necessary information to allow the Independent Observer to understand the evaluation models and to enable the Independent Observer to observe the entire analysis to ensure a fair process. The evaluation models will be finalized prior to the receipt of Proposals.

4.4.1 Initial Evaluation of the Price Related Criteria

For the initial price analysis, an equivalent energy price (Levelized \$/MWh) will be calculated for each renewable generation and renewable generation with energy storage proposal based on information provided in the Proposal including the Lump Sum Payment (\$/year), Price for Purchase of Electric Energy (\$/MWh), and the Net Energy Potential (“NEP”) RFP Projection (MWh) information defined in RFP Sections 3.9 and 3.10.

For standalone contingency storage proposals, and for the Contingency Storage portion of a renewable energy project paired with storage, a energy price (\$/MW) will be calculated for each Proposal based on information provided in the Proposal including the Lump Sum Payment (\$/year), and the facility’s contingency storage energy capability.

In order to fairly evaluate Proposals with different technologies and characteristics while using an equivalent energy price in Levelized \$/MWh at this stage in the evaluation, or in the case of contingency storage an Energy Storage Only Price in \$/MW, the Company will group Proposals into technology-based evaluation categories, as applicable. For example²¹: (1) Wind generation (MWh) only; (2) Wind generation (MWh) and Energy storage; (3) Solar generation (MWh) only; (4) Solar generation (MWh) and Energy storage; (5) Contingency storage only; (6) Wind generation (MWh), Energy Storage, and Contingency Storage; and (8) Solar generation (MWh), Energy Storage, and Contingency Storage.

²¹ There may be other technologies that are offered in this RFP. This list is illustrative of how technology-based evaluation categories will be established for the Initial Evaluation.

The Eligible Proposal with the lowest LEP in each evaluation category will receive 600 points. All other Eligible Proposals in that evaluation category will receive points based on a proportionate reduction using the percentage by which the Eligible Proposal's LEP exceeds the lowest LEP in that evaluation category. For example, if a Proposal's LEP is ten percent (10%) higher than the lowest LEP in that evaluation category, the Proposal will be awarded 540 points (that is, 600 points less 10%). The result of this assessment will be a ranking and scoring of each Proposal within each evaluation category.

4.4.2 Initial Evaluation of the Non-Price Related Criteria

For the non-price analysis, each Proposal will be evaluated on each of the eight (8) non-price criteria categories set forth below:

- Community Outreach and Cultural Resource Impacts
- State of Project Development and Schedule
- Performance Standards
- Environmental Compliance and Permitting Plan
- Experience and Qualifications
- Financial Strength and Financing Plan
- RDG PPA or ESPPA Contract Exceptions
- Guaranteed Commercial Operations Date

Each of the first three criteria – Community Outreach and Cultural Resource Impacts, State of Project Development and Schedule, Performance Standards – will be weighted twice as heavily as the others to reflect the impact these categories have to achieve a successful and timely procurement. The non-price criteria are generally scored on a scale of 1 (poor) to 5 (highly preferable).

The total non-price score will be the sum of the scores for each of the individual non-price criteria. The Company will then award non-price evaluation points in accordance with the relative ranking of scores within each evaluation category. The Proposal in each evaluation category with the highest total non-price score will receive 400 points, and all other Proposals will receive points equal to the Proposal's score divided by the top score, multiplied by 400.

During the non-price criteria evaluation, a fatal flaws analysis will also be conducted such that any Proposal that is deemed not to meet the minimum standards level²² for four (4) or more non-price criteria will be disqualified given that the Proposal has failed to meet a majority of non-price factors that are indicative as to the general feasibility and operational viability of a proposed Project.

The Companies' evaluation of the non-price criteria will be based on the materials provided by a Proposer in its Proposal. Acceptance of any Proposal into the Final Award Group shall not be assumed or construed to be an endorsement or approval that the materials provided by Proposer are complete, accurate or in compliance with applicable

²² A score of 3 is the "meets minimum standards" level that a Proposal must achieve in at least five (5) criteria.

law. The Companies assume no obligation to correct, confirm or further research any of the materials submitted by Proposers. Proposers retain sole responsibility to ensure their Proposals are accurate and in compliance with all laws.

The non-price criteria are:

- **Community Outreach and Cultural Resource Impacts** – Gaining community support is an important part of a Project’s viability and success. An effective Community Outreach Plan will call for early meaningful communications with stakeholders and will reflect a deep understanding and respect for the community’s desire for information to enable them to make informed decisions about future projects in their communities. Therefore, Proposals will be evaluated on the quality of the Community Outreach Plan to inform the Project’s impacted communities. Proposers need to also be mindful of the Project’s potential impacts to historical and cultural resources. Proposers should at least identify (1) valued cultural, historical, or natural resources in the area in question, including the extent to which traditional and customary native Hawaiian rights are exercised in the area; (2) the extent to which those resources – including traditional and customary native Hawaiian rights – will be affected or impaired by the proposed action; and (3) the feasible action, if any, to be taken to reasonably protect native Hawaiian rights if they are found to exist.

At a minimum, Proposals should include a Community Outreach Plan that describes the Proposer’s commitment to work with the neighboring community and stakeholders and to provide timely Project information during project development, construction, and operation. The Community Outreach Plan shall include, but not be limited to the following:

- 1) **Project description.** A thorough description including a map of the location of the Project. This information will help the community understand the impact that the Project may have on the community.
- 2) **Community scoping.** Identify stakeholders (individuals, community leaders, organizations), community issues and concerns, and community sentiment.
- 3) **Project benefits.** An explanation of the need for the Project. This will help the community to understand how the Project might benefit their community.
- 4) **Government approvals.** Required government permits and approvals, public hearings and other opportunities for public comment. This information will help the community to understand the level of public scrutiny and participation that might occur for the Project and the opportunities to provide public comments.
- 5) **Development process.** A Project schedule that identifies key milestones will facilitate the community’s understanding of the development process.

- 6) **Communications Plan.** A communications plan including a detailed community outreach schedule that will keep the affected communities and stakeholders informed about the Project's outreach efforts during early Project development period through construction and operations.

Preference will be given to Proposers who have already identified established contacts to work with the local community, have used community input to incorporate changes to the final design of the Project and mitigate community concerns, have proposed a community benefits package (including details of the community recipients and benefits package), or have community consultants as part of the Project team doing business in Hawai'i that have successfully worked with communities in Hawai'i on the development of two or more energy projects or projects with similar community issues. These criteria are aligned with the Companies' community engagement expectation whereby all developers will be required to engage in community outreach prior to signing a PPA with the Companies. This process is also outlined in RFP Section 5.3.

Also, at a minimum, Proposers should have already contracted with a consultant with expertise in such field to begin a cultural impact assessment for the Project. Preference will be given to Proposals that are further along in the assessment process and are able to provide a mitigation/action plan or are able to provide a date for when a mitigation/action plan will be available that addresses any identified cultural resource issues.

- **State of Project Development and Schedule** – Projects that are further along in development generally have lower project execution risk and a greater probability of being able to be successfully placed into service prior to the GCOD (specifically identified in each Proposal). At a minimum, Projects should demonstrate how they plan to capture any ITC safe harbor and reach their GCOD specified, including identification of risks and schedule assumptions. (Schedules must identify the IRS completion date and PUC approval dates assumed.) Proposals should also demonstrate, via a detailed critical path schedule, that there is a high likelihood that the Project will be able to reach commercial operations as specified. Proposals shall include a Gantt chart that clearly illustrates the overall schedule and demonstrates achievement of any ITC safe harbor, if applicable, and commercial operations by their specified GCOD. The Gantt chart shall include task durations and dependencies, identify tasks that will be fast tracked, and identifies slack time and contingencies. This criterion will also look at the high-level Project costs set forth in the Proposal including: costs for equipment, construction, engineering, Seller-Owned Interconnection Facilities, Company-Owned Interconnection Facilities, land, annual O&M, the reasonableness of such costs and the assumptions used for such costs. Project costs that do not appear reasonable for a project of the size proposed may result in a lower ranking for this criterion if the Company reasonably determines that the cost information is unrealistic based on prior experience in the market which may result in a risk that the Project can be built on time and for the price proposed by the Proposer. The Company reserves the right to discuss any cost and financial information with a Proposer to ensure the information provided is accurate and correct.

- **Performance Standards:** The proposed Facility must be able to meet the performance attributes identified in this RFP and the Performance Standards identified in the RDG PPA or the ESPPA. The Company will review the Proposal information received, including design documents and operating procedures materials provided in the Proposal, and evaluate whether the Project as designed is able to meet the Performance Standards identified in the RDG PPA or ESPPA (including the Project’s ability to provide Fast Frequency Response if the Proposal includes a Contingency Storage component or is for standalone contingency reserve storage) and in this RFP. At a minimum, in addition to meeting the Performance Standards, the Proposals should include sufficient documentation, provided in an organized manner, to support the stated claim that the Facility will be able to meet the Performance Standards. The Proposal should include information required to make such a determination in an organized manner to ensure this evaluation can be completed on a timely basis. Preference will be given to Proposals that provide detailed technical and design information showing how each standard can be met by the proposed Facility. Preference will also be provided to proposed Projects that offer additional capabilities (e.g., Black-Start, Grid-Forming).
- **Environmental Compliance and Permitting Plan** – This criterion relates to the potential (short- and long-term) environmental impacts associated with each project, the quality of the plan offered by the Proposer to mitigate and manage any environmental impacts (including any pre-existing environmental conditions), and the plan of Proposers to remain in environmental compliance over the term of the contract. These impacts are reflected on a technology-specific basis. Completing any necessary environmental review and obtaining the required permitting in a timely manner is also important and Proposals will be evaluated on their plan to identify, apply for, and secure the required permits for the Project, any permitting activity that has been completed to date, including having initial discussions with U.S. Fish and Wildlife and State of Hawai‘i Department of Land and Natural Resources, Division of Forestry and Wildlife, to the extent applicable, prior to submitting a Proposal, and the degree of certainty offered by the Proposer in securing the necessary permits.

At a minimum, proposed Projects should be expected to have minimal environmental impact for most areas and Proposals should provide a comprehensive plan to mitigate the identified potential or actual significant environmental impacts to remain in environmental compliance. The proposed mitigation plans should be included in the Project timeline. Preference will be given to Proposals that provide a more detailed plan as well as those that have proactively taken steps to mitigate potential environmental impacts.

Also, this criterion requires that, at a minimum, Proposers should have identified, and disclosed in their Proposal(s), all major permits, approvals, appurtenances and entitlements (including applicable access, rights of way and/or easements) (collectively, the “permits”) required and have a preliminary plan for securing such permits. Preference will be given to Proposals that are able to provide a greater degree of certainty that its plan to secure the required permits is realistic and achievable, or have already received all or a majority of the required

permits. The Proposer should disclose all identified (a) discretionary permits required, i.e., those requiring public or contested case hearings and/or review and discretionary approval by an appropriate government agency and (b) ministerial conditions without discretionary approval conditions. In all cases, the Proposer must provide a credible and viable plan to secure all necessary and appropriate permits necessary for the project. For example, if the project is located within an agricultural district, the Proposer shall provide evidence of Proposer's verification with the appropriate government agency that the project complies with HRS Section 205-2 and Section 205-4.5, relating to solar energy facilities placed on agricultural land, provided, however that where a special use permit (under Section 205-6), exemption (under Section 205-6), or amendment to land use district boundary lines (under Section 205-4) is required to secure such compliance, Proposer shall identify the need for such permit, exemption or amendment and provide a list of required prerequisites and/or conditions and a realistic timeline necessary to obtain such permit, exemption or amendment satisfactory for Proposer to still meet its designated GCOD.

- **Experience and Qualifications** – Proposals will be evaluated based on the experience of the Proposer in financing, designing, constructing, interconnecting, owning, operating, and maintaining projects (including all components of the project) of similar size, scope and technology. At a minimum, Proposals must show via the table format specified in RFP Appendix B Section 2.13 that at least one (1) member must have the specific experience in each of the following categories: financing, designing, constructing, interconnecting, owning, operating, and maintaining at least one electricity generation project including all components of the project similar to the Project being proposed. Preference will be given to Proposers with experience in successfully developing multiple projects that are similar to the one being proposed and/or that have prior experience successfully developing and interconnecting a utility scale project to the Company's System.
- **Financial Strength and Financing Plan** – This criterion addresses the comprehensiveness and reasonableness of the financial plan for the Project as well as assesses the financial strength and capability of the Proposer to develop the Project. A complete financial plan addresses the following issues: Project ownership, capital cost and capital structure, sources of debt and equity, and evidence that credit-worthy entities are interested in financing the Project. The financial strength of Proposers or their credit support providers will be considered, including their credit ratings. The financing participants are expected to be reasonably strong financially. Developers and their sources of capital that have investment grade credit ratings from a reputable credit rating agency (S&P, Moody's, Fitch) will also be given preference, with those that have higher credit ratings ranked higher.
- **RDG PPA or ESPPA Contract Proposed Modifications** – Proposers are encouraged to accept the contract terms identified in the model agreements in their entirety in order to expedite the overall RFP process and potential contract

negotiations. Proposers who accept the model agreements without edits will receive a higher score and will be the only proposals that can achieve the highest scoring for this non-price evaluation. Technology-specific or operating characteristic-required modifications, with adequate explanation as to the necessity of such modifications, will not jeopardize a project's ability to achieve the highest score. Proposers who elect to propose modifications to the model agreements shall provide a Microsoft Word red-line version of the applicable document identifying specific proposed modifications to the model agreement language as well as a detailed explanation and supporting rationale for each modification. General comments without proposed alternate language, drafting notes without explanation or alternate language, footnotes such as "parties to discuss," or a reservation of rights to make additional modifications to the model agreements at a later time are unacceptable, will be considered unresponsive, and will result in a lower score. The Company and Independent Observer will evaluate the impact that the proposed modifications will have on the overall risk assessment associated with the evaluation of each Proposal.

- **Guaranteed Commercial Operations Date:** The Company is procuring resources and incorporating projects onto its System in Stages as part of its long-term plan to meet RPS goals. Proposers will be held to the Guaranteed Commercial Operations Date identified in their Proposal. The GCOD will be a Guaranteed Milestone and will be inserted without amendment into the RDG PPAs or ESPPA, as applicable. Proposers that are able to design for and commit to an earlier GCOD will be given more favorable scoring. Proposers must have met the GCOD requirements of RFP Sections 1.2.18 and 1.2.19 prior to being evaluated in this non-price criterion.

4.5 Selection of a Priority List

At the conclusion of both the price and non-price analysis, a total score will be calculated for each Proposal using the 60% price-related criteria / 40% non-price-related criteria weighting outlined above. The price and non-price analysis, and the summation of both price and non-price scores described above, will result in a ranking of proposals within each technology-based evaluation category.

The Company will determine a Priority List from the highest scoring Proposals for each technology-based evaluation category. Each Priority List will include a sufficient number of projects, but not less than 2 Proposals per technology-based evaluation category, such that the Company can assemble portfolio combinations that meet or exceed the Renewable Energy MWh and Storage MW and MWh targets for comparison in the Detailed Evaluation. The Companies will develop the Priority Lists in consultation with the Independent Observer. The Companies reserve the right, in consultation with the Independent Observer, to limit the projects allowed for further consideration in the initial evaluation to projects that fall within 15% of the lowest price proposed per technology-based evaluation category. Selection to the Priority List does not assure an eligible Project's inclusion in the selection of the Final Award Group.

4.6 Best and Final Offer (BAFO)

4.6.1 The Company will solicit a Best and Final Offer from Proposers selected to a Priority List in a technology-based evaluation category. If the SBO is selected to a Priority List, the SBO will not be eligible to provide a Best and Final Offer and the original pricing submitted in its Self-Build Proposal will be used in the Detailed Evaluation. All other Proposers selected to a Priority List will have the opportunity to update (downward only)²³ the pricing elements in their Proposal to improve the competitiveness of their Proposal prior to being further assessed in the Detailed Evaluation phase. At this time, updates may only be made to the following pricing elements:

- Lump Sum Payment (\$/year) amount
- Price for Purchase of Electric Energy (\$/MWh) amount. Payment for delivery of net energy sourced from the variable generation resource, if applicable. No Energy Payment will be provided for any energy delivery that is sourced originally from the grid (Company's System).

Proposers will not be allowed to increase their price²⁴ but may elect to maintain the same pricing submitted in their original Proposal. Proposers will not be allowed to make any other changes to their Proposal during the Best and Final Offer.

4.6.2 If a Proposer does not propose improvements to their pricing elements during the Best and Final Offer solicitation, the original Proposal pricing elements will be deemed its Best and Final Offer.²⁵

4.7 Detailed Evaluation

The Best and Final Offers of the Priority List Proposals from this RFP, the Best and Final Offers of the Short List Proposals for contingency storage from the Grid Services RFP, as well as original Self-Build Proposals if advanced to the Priority Listed Proposals, will be further assessed in the Detailed Evaluation to identify the Priority List Proposals that meet the variable renewable dispatchable generation MWh and contingency storage MW targets to determine the Proposals selected to the Final Award Group.

The Initial Evaluation for the Grid Services RFP and this RFP will occur in parallel. A combined evaluation for Grid Services FFR-1 and this RFP's contingency storage proposals will take place after the completion of the BAFO rounds for each RFP, which will ensure that the proposals being considered have met eligibility and threshold requirements, represent the highest overall ranked projects based on price and non-price

²³ Proposers will only be allowed to adjust pricing elements downward. No upward adjustment to the pricing elements will be permitted or considered. All other characteristics of the Proposal and Facility capabilities must remain valid and unchanged (e.g., NEP, GCOD, etc.)

²⁴ Proposers will not be allowed to increase the pricing in their Proposals to address interconnection and/or system upgrade costs or for any other reason.

²⁵ The Company reserves the right in consultation with the Independent Observer, to adjust the parameters of the BAFO, in the unlikely event that system needs have evolved in a way that the Proposals received do not fully address.

criteria, and have incorporated Best and Final pricing. If possible based on the number and quality of Proposals received, the Company will attempt to include in the joint evaluation Projects totaling 18 MW of contingency storage on the Priority List for contingency storage for the Renewable RFP and 18 MW of FFR-1 on the Short List for the Grid Services RFP. An Energy Storage Only Price (\$ / MW) will be calculated for each FFR-1 proposal and proposed contingency storage project, including both standalone storage projects as well as storage projects paired with renewable generation (the Company notes that the issues for calculating the NPV for determination of the levelized price for FFR proposals are further discussed in the Grid Services RFP evaluation document). The Company will evaluate all FFR-1 and contingency storage proposals and rank them by lowest Energy Storage Only Price. The top-rated proposals (lowest cost) summing to 18MW will be selected as contingency storage proposal awardees (NOTE: contingency storage selection will incorporate locational constraints not applicable to the Grid Services FFR selection). For renewable energy projects paired with storage which include a Contingency Storage option: a) if the project **is** selected as a contingency storage Proposal awardee, in order for the project to be confirmed to the Final Award Group (such confirmation is subject to the further considerations described below), it must also be included in the portfolio of projects selected to meet the energy requirements of this RFP; and b) if the project **is not** selected as a contingency storage Proposal awardee, a variation of the project without contingency storage may still continue to be considered in this RFP as a renewable energy project paired with storage that meets the energy requirements of this RFP.

The Company will build Portfolios for evaluation that meet both the energy MWh target and the contingency storage MW target.

The detailed evaluation process will consist of assessment of combinations of Proposals from the Priority Lists that meet the energy and contingency storage targets of this RFP (“Portfolios”). A production simulation iteration will be created for each Portfolio to evaluate the Total Net Cost (Cost and Benefits) of integrating the Portfolio onto the Company’s System. Each Portfolio’s Total Net Cost will be compared against the Base Case, described further below.

The Company intends to use a computer model for this analysis. The evaluation will be based on the Total Net Cost (Costs and Benefits) to the Company of integrating the combination of Priority List Proposals onto the Company’s System which includes:

1. The cost to dispatch the combination of Projects and the energy and storage purchased;
2. The fuel cost savings (benefits) and any other direct savings (IPP savings from dispatchable fossil fuel savings) resulting from the displacement of generation by the Priority List Proposals, including consideration of round-trip efficiencies for facilities with storage;
3. The estimated increase (or decrease) in operating cost, if any, incurred by the Company to maintain system reliability; and

4. The cost of imputed debt, if applicable.

As noted, the Company will take into account the cost of rebalancing its capital structure resulting from any debt or imputed debt impacts associated with each Proposal (including any costs to be incurred by the Company, as described above, that are necessary in implementing the Proposal). The Company proposes to use the imputed debt methodology published by S&P that is applicable to the Proposal being evaluated. S&P views long-term PPAs as creating fixed, debt-like financial obligations that represent substitutes for debt-financed capital investments in generation capacity. By adjusting financial measures to incorporate PPA-fixed obligations, greater comparability of utilities that finance and build generation capacity and those that purchase capacity to satisfy new load are achieved.

During the Detailed Evaluation and before the Proposals advance to the Final Award Group, the Company will perform load flow analyses to determine if certain Project combinations introduce transmission circuit constraints that will factor into the selection process. This is to address the possibility that even though sufficient line capacity was identified for an individual Project, large Projects on separate transmission circuits that are in close proximity with each other could introduce additional transmission circuit constraints. The Projects selected must not have any additional constraints imposed based on the load flow analysis to advance to the Final Award Group. However, the Company reserves the right, in consultation with the Independent Observer, to allow minor modifications to a Proposal to avoid such additional constraints. If such modification resulted in a reduced size of the Facility, the pricing proposed would also need to be revised. Under no circumstances would a Proposer be allowed to increase their price as a result of such minor modification.

Also in the Detailed Evaluation, other factors will be validated to ensure that the final combination of Projects provides the contemplated benefits that the Company seeks. The Company will evaluate the collateral consequences of the implementation of a combination of Projects, including consideration of the geographic diversity, resource diversity, interconnection complexity, and flexibility and latitude of operation control of the Projects.

The Company may assess additional combinations of Projects if requested by the Independent Observer and if the time and capability exist to perform such analyses.

4.8 Selection of the Final Award Group

Based on the results of the Detailed Evaluation and review of the results with the Independent Observer, the Company will select a Final Award Group from which to begin contract negotiations. The Company intends to select projects that meet the targeted needs and provide customer benefits. All Proposers will be notified at this stage of the evaluation process whether their Proposal is included in the Final Award Group.

Selection to the Final Award Group and/or entering into contract negotiations does not guarantee execution of a PPA.

Further, if at any time during the evaluation process it is discovered that a Proposer's Proposal contains incorrect or misrepresented information that have a material effect on any of the evaluation processes, including selection of the Priority List or the Final Award Group, the Company reserves the right, at any time prior to submission of the PPA Application with the PUC application, in consultation with the Independent Observer, to disqualify the Proposer from the RFP. If discovery of the incorrect or misrepresented information is made after the Company has filed its PUC application for approval of the PPA with the Proposer, the Company will disclose the incorrect or misrepresented information to the PUC for evaluation and decision as to whether such Proposer should be disqualified and the Company's application dismissed.

Following any removal of a proposal from the Final Award Group, either by disqualification noted immediately above, or via any other removal or withdrawal of a proposal, including failure to reach agreement to the PPA, the Company, taking into consideration the timing of such removal and the current status of the Company's needs under the RFP, in consultation with and concurrence from the Independent Observer, will review the Priority List to determine (1) if another proposal should be added to the Final Award Group; (2) if either of the Contingency Plan or Parallel Plan should be pursued; or (3) if the remaining proposals in the Final Award Group should remain unchanged.

Order No. 36536 "directs the Companies to work with the [Independent Observers] to increase bid transparency within the RFP process, while maintaining an appropriate level of confidentiality regarding bids and bidders." The Companies agree that it is desirable for the RFP process to be as transparent as possible while maintaining the confidentiality of Proposer and Proposal information. The type and quantity of information that can be disclosed will not be known until the Companies and the Independent Observer have a better understanding of the number and types of proposals received and whether such information can be easily anonymized. The Companies will work with the Independent Observers to determine an appropriate level of disclosure after Proposals are received with a goal of disclosing more information than was disclosed in Stage 1.

Chapter 5: Post Evaluation Process

5.1 Interconnection Requirements Study Process

A complete package of IRS Data Request worksheets and project single line diagram(s) shall be submitted with each Proposal. For Projects with a proposed GCOD in 2022, the models for equipment and controls, list(s) to clearly identify the components and respective files (for inverters and power plant controller), and complete documentation with instructions, shall be submitted within 60 days thereafter. See Section 2.11.1 of Appendix B. For all other Projects, the same complete submittal shall be due within 60 days after selection to the Final Award Group. PSSE Generic models, PSSE User models, and ASPEN models shall be configured to represent all of the functional equipment with settings in place to comply with the Company's PPA performance requirements. These must be checked for functionality by the Proposer or its vendors and

consultants prior to submission to the Company. Similar and fully accurate PSCAD models shall be submitted in a condition that complies with the PSCAD modeling guidelines provided by the Company. PSSE generic models shall be provided promptly after the PSSE user models have been approved by the Company.

After proposals and models are submitted, the Company will inspect the data packages for general completeness. For any incomplete submissions, a list of missing or non-functional items will be provided. Proposers will be given 15 Days to resolve data and modeling deficiencies. The Company, in consultation with the Independent Observer, may remove Proposals from the Priority List or Final Award Group, or may terminate PPA negotiations or executed PPAs if their submission requirements are deemed incomplete for the lack of requested models. Proposals that are complete will be considered for further evaluation. A formal, technical model checkout will be deferred until a later date when IRS Agreements and deposits are in place, so that the expert subject matter work can be provided by the Company's IRS consultant(s).

Upon notification of selection to the Final Award Group, the Company will provide a draft IRS Agreement for each selected project, with a statement of required deposit for individual and prorated work as part of an IRS Scope for a System Impact Study that will involve (a) technical model checkout for each project, (b) any considerations that are specific to a particular project and location, and (c) system impact analyses of the projects as a group. Interconnection cost and schedule, including cost of any required system upgrades, will be determined in a subsequent Facilities Study.

The technical model checkouts will be conducted first. Upon identification of any functional problems or deficiencies, corrective action shall be taken immediately and on an interactive basis so that the problems or deficiencies can be resolved within 15 Days, including re-submission of data and updated models, or the project shall be deemed withdrawn. At the discretion of the Company and provided that there is a demonstration of good faith action to minimize delay that would affect the schedule for IRS analyses, a second round of model checkout and problem solving may proceed. Thereafter any notice that a Project is deemed withdrawn for lack of completeness shall be final. Subject to consultation with the Independent Observer, failure to provide all requested material within the time(s) specified, or changes to the data provided after the due date(s), shall result in elimination from the Final Award Group.

Proposers shall be responsible for the cost of the IRS, under separate agreements for the System Impact Study and the Facilities Study. The overall IRS will provide information including, but not limited to, an estimated cost and schedule for the required Interconnection Facilities for a particular Project and any required mitigation measures. Proposers will be responsible for the actual final costs of all Seller-Owned Interconnection Facilities and Company-Owned Interconnection Facilities. Upon reviewing the results of the IRS, Proposers will have the opportunity to declare the PPA null and void in the event that the estimated interconnection costs and schedule for the Project are higher than what was estimated in the Project Proposal. See Section 12.4 of the RDG PPA or Section 2.3(b) of the ESPPA.

5.2 Contract Negotiation Process

Within five (5) business Days of being notified by the Company of its intent to enter into contract negotiations, Proposers selected for the Final Award Group will be required to indicate, in writing to the Company's primary contact for this RFP, whether they intend to proceed with their Proposals. Proposers who elect to remain in the Final Award Group will be required to keep their Proposal valid through the award period. Contract negotiations will take place in parallel with the IRS process. Given the significant scope of the RFP, and depending on the number of Projects selected to the Final Award Group, the Company will prioritize which Projects to negotiate with first. The Company will first prioritize Projects that meet the identified 18 MW Fast Frequency Response need. Prioritization will take into consideration the GCOD of the Project, the benefits to and the needs of the Company's System, and extensiveness of the exceptions to the model PPA. While PPA negotiations and submission of executed PPAs for approval will take place on a rolling basis, the Company's goal is to begin to complete this process for the first projects within six (6) months of notification of intent to enter contract negotiations. The IRS may not be completed at such time. The Company intends to execute and file the PPA with the PUC for approval and later amend the PPA to include the results of the IRS.

5.3 Community Outreach and Engagement

The public meeting and comment solicitation process described in this Section and Section 29.21 of the model RDG PPA or Section 27.17 of the model ESPPA (Community Outreach Plan) do not represent the only community outreach and engagement activities that can or should be performed by Proposer. Within 30 Days of the start of PPA negotiations, Proposers shall have provided the Company with an updated comprehensive Community Outreach Plan to work with and inform neighboring communities and stakeholders and to provide them timely information during all phases of the Project. The Community Outreach Plan shall include, but not limited to the following information: Project description, Project stakeholders, community concerns and Proposer's efforts to address such concerns, Project benefits, government approvals, Project schedule, and a comprehensive communications plan. Upon selection to the Final Award Group, a Proposer's Community Outreach Plan shall be a public document available to the public on the Proposer's website and upon request. The Proposer shall also provide the Company with links to their Project website and Community Outreach Plan, which the Company will post on the Company's website. Prior to the execution date of the PPA Proposers shall also host a public meeting in the community where the proposed Project is to be located for community and neighborhood groups in and around the vicinity of the Project Site that provided the neighboring community, stakeholders and the general public with: (i) a reasonable opportunity to learn about the proposed Project; (ii) an opportunity to engage in a dialogue about concerns, mitigation measures, and potential community benefits of the proposed Project; and (iii) information concerning the process and/or intent for the public's input and engagement, including advising attendees that they will have thirty (30) calendar days from the date of said public meeting to submit written comments to Company and/or Proposer for inclusion in the Company's submission to the PUC of its application for a satisfactory PUC Approval

Order. The Proposer shall collect all public comments, and then provide the Company copies of all comments received in their original, unedited form, along with copies of all comments with personal information redacted and ready for filing. If a PPA is executed by the Proposer and the Company, the Company may submit any and all public comments (presented in its original, unedited form) as part of its PUC application for this Project. Proposers shall notify the public at least three weeks in advance of the meeting. The Company shall be informed of the meeting. The Company will provide Proposers with detailed instructions regarding the community meeting requirement after the selection of the Final Award Group. (For example, notice will be published in county or regional newspapers/media, as well as media with statewide distribution. The Proposer will be directed to notify certain individuals and organizations. The Proposer will be provided templates to use for the public meeting notices, agenda, and presentation.) Proposers must also comply with any other requirement set forth in the PPA relating to Community Outreach.

Following the submission of the PUC application for the Project, and prior to the date when the Parties' statements of position are to be filed in the docketed PUC proceeding for the Project, the Proposer shall provide another opportunity for the public to comment on the proposed Project. The Proposer's statement of position filed in the docket associated with the Project will contain an attachment including those comments.

The Proposer shall be responsible for community outreach and engagement for the Project, and that the public meeting and comment solicitation process described in this section do not represent the only community outreach and engagement activities that can or should be performed.

5.4 Greenhouse Gas Emissions Analysis

Proposers whose Proposal(s) are selected for the Final Award Group shall cooperate with and promptly provide to the Company and/or the Company's consultant(s) upon request all information necessary, in the Company's sole and exclusive discretion, for such consultant to prepare a greenhouse gas ("GHG") emissions analysis and report in support of a PUC application for approval of the PPA for the project (the "GHG Review"). Proposers shall be responsible for the full cost of the GHG Review associated with their project under a separate agreement between the Proposer and the Company. The GHG Review is anticipated to address whether the GHG emissions that would result from approval of the PPA and subsequent to addition of the Project to the Company's System are greater than the GHG emissions that would result from the operations of the Company's System without the addition of the Project, whether the cost for renewable, dispatchable generation, and/or energy storage services as applicable under the PPA is reasonable in light of the potential for GHG emissions, and whether the terms of the PPA are prudent and in the public interest in light of its potential hidden and long-term consequences.

5.5 PUC Approval of PPA

Any signed PPA resulting from this RFP is subject to PUC approval as described in the RDG PPA, including Article 12 and Section 29.20 thereof, or Article 24 of the ESPPA.

5.6 Facility In-Service

In order to facilitate the timely commissioning of the numerous projects required to meet the MW and MWh targets of this RFP, the Company requires the following be included with the 60% design drawings: relay settings and protection coordination study, including fuse selection and ac/dc schematic trip scheme.

For the Company to test the facility, coordination between the Company and Project is required. Drawings must be approved by the Company prior to testing. The entire facility must be ready for testing to commence. Piecemeal testing will not be allowed. Communication infrastructure and equipment must be tested by the IPP and ready for operation prior to Company testing.

If approved drawings are not available, or if the facility is otherwise not test ready as scheduled, the Project will be moved to the end of the Company's testing queue. If tests are not completed within the allotted scheduled testing time, the Project will be moved to the end of the Company's testing queue. The IPP will be allowed to cure if successful testing is completed within the allotted scheduled time. No adjustments will be made to PPA milestones if tests are not completed within the original allotted time. Liquidated damages for missed milestones will be assessed pursuant to the PPA.

REQUEST FOR PROPOSALS
FOR
VARIABLE RENEWABLE DISPATCHABLE GENERATION
AND
ENERGY STORAGE
ISLAND OF HAWAI‘I

AUGUST 22, 2019

Docket No. 2017-0352

Appendix A – Definitions



**Hawai‘i
Electric
Light**

“Affiliate” means any person or entity that possesses an “affiliated interest” in a utility as defined by section 269-19.5, Hawaii Revised Statutes (“HRS”), including a utility’s parent holding company but excluding a utility’s subsidiary or parent which is also a regulated utility.

“Allowed Capacity” has the meaning set forth in the RDG PPA and ESPPA.

“Best and Final Offer” or “BAFO” means the final offer from a Proposer, as further described in Section 4.6 and elsewhere in this RFP.

“Code of Conduct” means the code of conduct approved by the PUC in Docket No. 03-0372 (Decision and Order No. 23614, August 28, 2007) with respect to a Self-Build Option. An updated code of conduct was submitted to the PUC in Docket No. 2017-0352 on October 23, 2017.

“Code of Conduct Procedures Manual” or “Procedures Manual” means the manual approved by the PUC, which was put in place to address and to safeguard against preferential treatment or preferential access to information in a Hawaii Electric Light RFP process. The Procedures Manual is attached as Appendix C to this RFP.

“Commercial Operations” has the meaning set forth in the RDG PPA and ESPPA.

“Community Outreach Plan” is a community outreach and communication plan described in Section 4.3 and 4.4.2 of this RFP.

“Company” means Hawaii Electric Light Company, Inc., a Hawai‘i corporation.

“Company-Owned Interconnection Facilities” has the meaning set forth in the RDG PPA and ESPPA.

“Competitive Bidding Framework” or “Framework” means the Framework for Competitive Bidding contained in Decision and Order No. 23121 issued by the Public Utilities Commission on December 8, 2006, and any subsequent orders providing for modifications from those set forth in Order No. 23121 issued December 8, 2006.

“Consumer Advocate” means the Division of Consumer Advocacy of the Department of Commerce and Consumer Affairs of the State of Hawai‘i.

“Contingency Storage” is a contingency storage component, added to a generation proposal paired with an energy storage component, to provide Fast Frequency Response.

“Day” means a calendar day, unless the term “business day” is used, which means calendar day excluding weekends and federal and State of Hawai‘i holidays.

“Development Period Security” has the meaning set forth in Section 14.2 of the RDG PPA and Section 14.1 of the ESPPA.

“Dispatchable” means the ability to turn on or turn off a generating resource at the request of the utility’s system operators, or the ability to increase or decrease the output of a generating

resource from moment to moment in response to signals from a utility's Automatic Generation Control System, Energy Management System or similar control system, or at the request of the utility's system operators.

“Electronic Procurement Platform” means the third-party web-based sourcing platform that will be used for the intake of Proposals and associated electronic information, storage and handling of Proposer information, and communication.

“Eligibility Requirements” has the meaning set forth in Section 4.2 of this RFP.

“Energy Contract Manager” is the primary Company contact for this RFP.

“ESPPA” means the Model Energy Storage Power Purchase Agreement attached as Appendix K to this RFP.

“Evaluation Team” means agents of the Company who evaluate Proposals.

“Facility” has the meaning set forth in the RDG PPA and ESPPA.

“Final Award Group” means the group of Proposers selected by the Company from the Priority List, with which the Company will begin contract negotiations, based on the results of the Company's detailed evaluation.

“Greenhouse Gas” or “GHG” are gases that contribute to the greenhouse gas effect and trap heat in the atmosphere.

“Guaranteed Commercial Operations Date” or “GCOD” means the date on which a Facility first achieves Commercial Operations.

“Hawaii Electric Light” means Hawaii Electric Light Company, Inc., a Hawai'i corporation.

“Hawaiian Electric Companies” or “Companies” means Hawaiian Electric Company, Inc. and its subsidiaries, Hawaii Electric Light Company, Inc. and Maui Electric Company, Limited.

“Hawaii Electric Light System” or “System” means the electric system owned and operated by Hawaii Electric Light on the island of Hawai'i (including any non-utility owned facilities) consisting of power plants, transmission and distribution lines, and related equipment for the production and delivery of electric power to the public.

“HRS” means the Hawai'i Revised Statutes as of the date of this Request for Proposals.

“Imputed Debt” means adjustments to the debt amounts reported on financial statements prepared under generally accepted accounting principles (“GAAP”). Certain obligations do not meet the GAAP criteria of “debt” but have debt-like characteristics; therefore, credit rating agencies “impute debt and interest” in evaluating the financial ratios of a company.

“Independent Observer” has the meaning set forth in Section 1.4 of this RFP.

“Independent Power Producer” or “IPP” means an entity that owns or operates an electricity generating facility that is not included in the Company’s rate base.

“Interconnection Facilities” means the equipment and devices required to permit a Facility to operate in parallel with, and deliver electric energy to, the Company System (in accordance with applicable provisions of the Commission’s General Order No. 7, Company tariffs, operational practices, interconnection requirements studies, and planning criteria), such as, but not limited to, transmission and distribution lines, transformers, switches, and circuit breakers. Interconnection Facilities includes Company-Owned Interconnection Facilities and Seller-Owned Interconnection Facilities.

“Interconnection Requirements Study” or “IRS” means a study, performed in accordance with the terms of the IRS Letter Agreement, to assess, among other things, (1) the system requirements and equipment requirements to interconnect the Facility with the Company System, (2) the Performance Standards of the Facility, and (3) an estimate of interconnection costs and project schedule for interconnection of the Facility.

“kV” means kilovolt.

“Land RFI” refers to a Request for Information activity conducted by the Company to identify interested parties willing to make land available for utility-scale renewable energy projects and gather relevant property information.

“Levelized Energy Price” or “LEP” means a calculation (\$/MWh) used for comparison of Proposals based on information provided in the Proposal submission in this RFP.

“Lump Sum Payment” has the meaning set forth in the RDG PPA or ESPPA. It may also be referred to as a monthly Lump Sum Payment to reflect the portion of the payment made each month.

“Mediation” means the confidential mediation conducted in Honolulu, Hawai‘i, pursuant to and in accordance with the Mediation Rules, Procedures, and Protocols of Dispute Prevention Resolution, Inc. (or its successor) or, in its absence, the American Arbitration Association then in effect.

“MW” means megawatt.

“MWh” means megawatt hour.

“NDA” means the Mutual Confidentiality and Non-Disclosure Agreement attached to this RFP as Appendix E.

“NEP” means Net Energy Potential.

“Non-Price Evaluation Team” means Employees and consultants of the Company who evaluate the Proposal non-price related criteria as set forth in Section 4.4 of this RFP. Non-Price Evaluation Team members will not include any Shared Resources and will be solely made up of Company RFP Team Members.

“O&M” means operation and maintenance.

“Operating Period Security” has the meaning set forth in Section 14.4 of the RDG PPA and Section 14.2 of the ESPPA.

“Performance Standards” means the various performance standards for the operation of the Facility to the Company as set forth in Section 3 of Appendix B, as such standards may be revised from time to time pursuant to Article 23 of the RDG PPA or Article 22 of the ESPPA, and as described in Chapter 2 of this RFP.

“Point of Interconnection” has the meaning set forth in the RDG PPA and ESPPA.

“Power Purchase Agreement” or “PPA” means an agreement between an electric utility company and the developer of a renewable energy generation facility to sell the power generated by the facility to the electric utility company.

“Power Supply Improvement Plan” or “PSIP” means the Company’s Power Supply Improvement Plan.

“Price Evaluation Team” means Employees and consultants of the Company who evaluate the Proposal price related criteria as set forth in Section 4.4 of this RFP. Price Evaluation Team members will not include any Shared Resources and will be solely made up of Company RFP Team Members.

“Price for Purchase of Electric Energy” is the amount that the Company will pay the Seller for electric energy delivered to the Company in accordance with the terms and conditions of the RDG PPA on a monthly basis as described in Attachment J. This payment will be calculated in terms of dollars per MWh.

“Priority List” means the group of Proposals selected by Hawaii Electric Light as described in Section 4.5 of this RFP.

“Project” means a Facility proposed to Hawaii Electric Light by a Proposer pursuant to this RFP.

“Proposal” means a proposal submitted to Hawaii Electric Light by a Proposer pursuant to this RFP.

“Proposal Due Date” means the date stated in RFP Schedule - Row 7 for the Self-Build and/or Affiliate Proposal and Row 8 for the IPP Proposal of this RFP.

“Proposal Fee” means the non-refundable fee of \$10,000 for each proposal submitted as set forth in Section 1.8 of this RFP.

“Proposer” means a person or entity that submits a Proposal to Hawaii Electric Light pursuant to this RFP.

“Proposer’s Response Package” means the form in which the Proposal should be submitted, which is attached as Appendix B to this RFP.

“PSIP Update Report: December 2016” or “PSIP” means the Company’s PSIP update filed on December 23, 2016 in Docket No. 2014-0183.

“PUC” means the State of Hawai‘i Public Utilities Commission.

“RDG PPA” means the Model PV and/or Wind Renewable Dispatchable Generation Power Purchase Agreement attached as Appendix J and Appendix L respectively to this RFP.

“Renewable Portfolio Standards” or “RPS” means the Hawai‘i law that mandates that the Company and its subsidiaries generate or purchase certain amounts of their net electricity sales over time from qualified renewable resources. The RPS requirements in Hawai‘i are currently codified in HRS §§ 269-91 through 269-95.

“Request for Proposals” or “RFP” means a request for Proposals issued pursuant to a competitive bidding process authorized, reviewed, and approved by the PUC.

“RFP Schedule” means the schedule set forth in Table 1, Section 3.1 of this RFP.

“Self-Build Option” or “SBO” means a Proposal submitted by the Company that is responsive to the resource need identified in the RFP, as required by Section VI of the Framework.

“Self-Build Team” means agents of the Company who develop Self-Build Option proposals.

“Seller” means the entity that the Company is contracting with, as set forth in the RDG PPA and ESPPA.

“Seller-Owned Interconnection Facilities” has the meaning set forth in the RDG PPA and ESPPA.

“Site” means the parcel of real property on which the Facility, or any portion thereof, will be constructed and located, together with any Land Rights reasonably necessary for the construction, ownership, operation and maintenance of the Facility.

“Site Control” has the meaning set forth in Section 4.3 of this RFP.

“Threshold Requirements” has the meaning set forth in Section 4.3 of this RFP.

Any capitalized term not defined in this RFP has the meaning set forth in the RDG PPA and ESPPA.

REQUEST FOR PROPOSALS
FOR
VARIABLE RENEWABLE DISPATCHABLE GENERATION
AND
ENERGY STORAGE
ISLAND OF HAWAI‘I

AUGUST 22, 2019

Docket No. 2017-0352

*Appendix B – Proposer’s Response Package /
IRS Data Sheet*

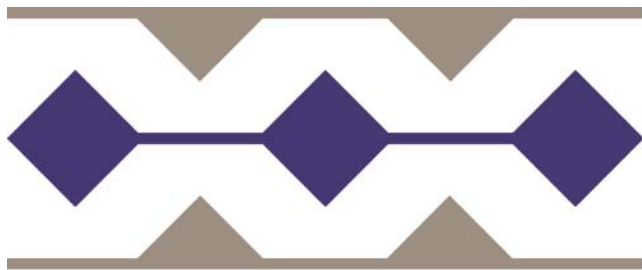

**Hawai'i
Electric
Light**

1.0 GENERAL INSTRUCTIONS TO PROPOSERS

The Company has elected to use the services of PowerAdvocate®, a third-party electronic platform provider. Sourcing Intelligence®, developed by PowerAdvocate®, is the Electronic Procurement Platform that the Company has licensed and will utilize for the RFP process. All Proposals and all relevant information must be submitted via the Electronic Procurement Platform, in the manner described in this RFP.

Proposers must adhere to the response structure and file naming conventions identified in this Appendix for the Proposer's response package. Information submitted in the wrong location/section or submitted through communication means not specifically identified by the Company will not be considered by the Company.

Proposers must provide a response for every item. If input/submission items in the RFP are not applicable to a specific Proposer or Proposal variation, Proposers must clearly mark such items as "N/A" (Not Applicable) and provide a brief explanation.

Proposers must clearly identify all confidential information in their Proposals, as described in more detail in Section 3.12 Confidentiality of the RFP.

All information (including attachments) must be provided in English. All financial information must be provided in U.S. Dollars and using U.S. credit ratings.

It is the Proposer's sole responsibility to notify the Company of any conflicting requirements, ambiguities, omission of information, or the need for clarification prior to submitting a Proposal.

The RFP will be conducted as a "Sealed Bid" event within Sourcing Intelligence, meaning the Company will not be able to see or access any of the Proposer's submitted information until after the event closes.

1.1 ELECTRONIC PROCUREMENT PLATFORM

To access the RFP event, the Proposer must register as a "Supplier"¹ on Sourcing Intelligence (Electronic Procurement Platform). One Proposal may be submitted with each Supplier registration. Minor variations, as defined in Section 1.8.2 and 1.8.3 of this RFP may be submitted along with the Proposal under the same registration.

If a Proposer is already registered on Sourcing Intelligence, the Proposer may use their current login information to submit their first Proposal. Minor variations of a Proposal will be submitted together with the base variation Proposal, following the instructions outlined in this Appendix. If the Proposer chooses to submit more than one Proposal, the Proposer must register as a new "Supplier" on Sourcing Intelligence for each additional Proposal. Proposers who participated in Stage 1 may reuse their registered Supplier accounts from Stage 1 for this Stage 2 RFP, however they should ensure that the account name (Company name) aligns with their Proposal being

¹ The language in Appendix B sometimes refers to "Energy Contract Managers" as "Bid Event Coordinator" and to "Proposers" as "Suppliers" (Bid Event Coordinator and Supplier are terms used by PowerAdvocate).

submitted in Stage 2 noting that Stage 2 RFP's submission structure differs from Stage 1 (Stage 2 does not require all variations to have a separate PowerAdvocate Supplier registration).

Each registration will require a unique username, unique Email address, and unique Company name. Proposers that require multiple registrations to submit multiple Proposals should use the Company name field to represent the Company name and Proposal number (ex: CompanyNameP1).² Proposers may use shorthand or clear abbreviations. Proposers are asked to refer to their chosen unique company name throughout when referring to it in text responses.

Proposers can register for an account on Sourcing Intelligence by clicking on the "Registration" button (located in the top right corner of the webpage) on the PowerAdvocate website at the following address:

www.poweradvocate.com

The Proposer's use of the Electronic Procurement Platform is governed by PowerAdvocate's Terms of Use. By registering as a "Supplier" on the Electronic Procurement Platform, the Proposer acknowledges that the Proposer has read these Terms of Use and accepts and agrees that, each time the Proposer uses the Electronic Procurement Platform, the Proposer will be bound by the Terms of Use then accessible through the link(s) on the PowerAdvocate login page.

Once a Proposer has successfully registered as a "Supplier" with PowerAdvocate, the Proposer shall request access to the subject RFP event from the Company Contact via Email through the RFP Email Address set forth in Section 1.6 of the RFP. The Email request must list the Company Name field and username under which the Proposer has registered with PowerAdvocate. If the Proposer plans to submit multiple Proposals and has registered multiple accounts in accordance with the instructions above, the Email request must contain the Company Name field and username for each account that will be used to submit the Proposals. After the Energy Contract Manager has added the Proposer to the event, the Proposer will receive an invitation to the RFP event at the registered Email account, and the Proposer will see the bid event on their dashboard upon logging into Sourcing Intelligence. Once the RFP event opens, the Proposer may begin submitting their Proposal(s).

After registering and prior to the opening of the RFP, Proposers are encouraged to familiarize themselves with the Electronic Procurement Platform, including tabs, the dashboard, the messaging feature, the Sourcing Intelligence Quick Start for Suppliers, etc. Proposers should note that they will not be able to access any bid documents until the event officially opens.

Proposers may contact PowerAdvocate Support for help with registration or modification of registration if desired. Support is available from 8 AM to 8 PM Eastern Time (2 AM to 2 PM Hawai'i Standard Time when daylight savings is in effect) Monday to Friday, except for Holidays posted on the PowerAdvocate website, both by phone (857-453-5800) and by Email (support@poweradvocate.com).

² In this Stage 2 RFP, a Proposer may submit up to three additional variations of their Project using a single registered Supplier account (Company name) which is different than what was required in Stage 1 where separate accounts were required for each variation. RFP Sections 1.8.2 and 1.8.3 describe the variations that can be submitted.

Contact information for PowerAdvocate Support can also be found on the bottom border of the PowerAdvocate website: www.poweradvocate.com

Once the RFP event is opened, registered Proposers will have online access to general notices, RFP-related documents, and other communications via the Electronic Procurement Platform. Proposers should also monitor the RFP Website throughout the RFP event.

1.2 PROPOSAL SUBMISSION PROCEDURES

An Email notification will be sent to all registered Proposers via the messaging feature in the Electronic Procurement Platform when the event has been opened to receive Proposals.

After logging onto the Electronic Procurement Platform, the RFP will be visible on the Proposer's dashboard with several tabs, including the following:

- “**1. Download Documents:**” Documents stored under this tab are provided for the Proposer's use and information. All documents can be downloaded and/or printed, as required.
- “**2. Upload Documents:**” Proposal submission documents requested in Appendix B must be uploaded using this tab.
- “3. Commercial Data:” This tab is NOT USED for this event.
- “4. Technical Data:” This tab is NOT USED for this event.
- “5. Pricing Data:” This tab is NOT USED for this event.

Step-by-step instructions for submitting a complete Proposal are provided below:

1. Proposers must upload their Proposal files, including all required forms and files, to submit a complete Proposal. All files must be uploaded before the Proposal Due Date.
2. Submit (upload) one consolidated PDF representing your Proposal via the “2. Upload Documents” tab. That Proposal PDF must abide by the format specified in this Appendix B. A MSWord.docx template that outlines the format of this document is available under the “1. Download Documents” tab for the Proposer's use. **Response information must be provided in the order, format, and manner specified in this Appendix B and must clearly identify and reference the Appendix B section number that the information relates to.**
 - a. Proposers shall use a filename denoting: CompanyName_Proposal#.pdf.
(example: AceEnergy_P1.pdf)
3. Proposal information that cannot be easily consolidated into the PDF file described in Step 2 (such as large-scale drawing files) or files that must remain in native file format (such as computer models and spreadsheets) shall be **uploaded separately but must be referenced from within the main Proposal PDF file** (e.g., “See AceEnergyP1V2_2.5_SiteControlMap.kmz”). Such additional files must follow the naming convention below:
 - a. File names must include, in order, Company Name, Proposal number (if more than one Proposal being submitted per Proposer), Variation (if any variations are being submitted), Appendix B section number, and a file descriptor, as shown in the example file name below:
AceEnergyP1V2_2.5_SiteControlMap.kmz

Proposers may use abbreviations if they are clear and easy to follow.

4. Upload files using the "**2. Upload Documents**" tab on the Electronic Procurement Platform.
 - a. For all documents identify the "Document Type" as "Technical Information." (Do not identify any documents as "Commercial and Administrative" or "Pricing.")
 - b. "Reference ID" may be left blank.
 - c. Select "Choose File..." Navigate to and choose the corresponding file from your computer. Select "Open" and then "Submit Document."

There is no limit to the number or size of files that can be uploaded. Multiple files may be grouped into a .zip archive for upload. (Any zipped files must still adhere to the naming directions in #3 above.) When successfully uploaded, documents will appear under the "Bid Submissions" section on the bottom of the tab's page, organized within the "Technical Information" Document Type. Repeat steps a, b, and c, as required for each file upload.

If a file with the same name is uploaded twice, the Platform will automatically append a unique numerical extension to the Document Name. To delete a file that has been previously uploaded, click on the "X" button in the "Actions" column for the file to be deleted. Do not upload any files prior to the issuance of the Final RFP.

5. The Company will not be responsible for technical problems that interfere with the upload or download of Proposal information. Support is available to answer technical questions about PowerAdvocate's Sourcing Intelligence from 8 AM to 8 PM Eastern Time (2 AM to 2 PM Hawai'i Standard Time when daylight savings is in effect) Monday to Friday, except for Holidays posted on the PowerAdvocate website, both by phone (857-453-5800) and by Email (support@poweradvocate.com).
6. Proposers are strongly encouraged to start early and avoid waiting until the last minute to submit the required information. Proposers are allowed to add, modify, and/or delete documents that have been previously submitted any time prior to the event close deadline.
7. Any questions or concerns regarding the RFP, may be submitted to the Company Contact via the RFP Email address provided in Section 1.6 of the RFP or via the PowerAdvocate Messaging tab. Per RFP Section 1.4.2, the Independent Observer will monitor messages within the bid event. Proposers are responsible for following instructions and uploading documents in their appropriate locations. Documents uploaded in the wrong tab will not be considered by the Company.

1.3 PROPOSAL COMPLETION AND CONFIRMATION PROCEDURES

To confirm the submission of all proposal files, in the “Status” tab on the Electronic Procurement Platform, confirm that the “Total Uploaded Files” is the number of expected files to be included in the submission by checking it against your list of submitted files.

Example “Status” tab view:

Your Bid Intention: Bidding		
Total Uploaded Files:	18	Last Upload: 02/08/18
Saved Commercial Datasheets:	0 of 0	
Saved Technical Datasheets:	0 of 0	
Saved Pricing Datasheets:	0 of 0	

2.0 PROPOSAL SUMMARY TABLE

Base variation Proposal Summary. If proposal variations are submitted, any changes to the summary information for such variations must be specifically identified in a similar table placed in sections 3.2, 3.3, 3.4, etc. of this Appendix, as applicable.

To be filled out by ALL Projects:

1	Proposer Name (Company Name)	
2	Parent Company/Owner/Sponsor/Business Affiliation/etc	
3	Project Name	
4	Net AC Capacity of the Facility (MW)	
5	Proposed Facility Location in/near what City/Area	
6	TMK(s) of Facility Location (9 digits)³	
7	Point of Interconnection's Circuit or Substation Name	
8	Proposal Contract Term (Years)	
9	Proposal Guaranteed Commercial Operations Date (MM/DD/YYYY)	
10	The Proposer hereby certifies that the Project meets all performance attributes identified in this RFP and the Performance Standards in the applicable RDG PPA or ESPPA? (Yes/No)	
11	The Proposer hereby certifies that no single point of failure from the Facility shall result in a decrease in net electrical output greater than 30 MW. (Yes/No)	
12	The Proposer hereby certifies that the Proposal (including its pricing elements) is not contingent upon changes to existing County, State or Federal laws or regulations. (Yes/No)	
13	The Proposer hereby agrees to provide Development Period Security and Operating Period Security as set forth in the applicable RDG PPA or ESPPA. (Yes/No)	
14	The Proposer hereby certifies under penalties of perjury that this Proposal has been made in good faith and without collusion or fraud with any other person. As used in this certification, the word "person" shall mean any natural person, business partnership, corporation, union, committee, club, or organization, entity, or group of individuals. (Yes/No)	
15	The Proposer hereby acknowledges that the Company reserves the right, per PUC Order 36536, to select less than the full amount of generation solicited in this RFP in the event that specific HELCO system needs (e.g. as a result of the availability of either or both of the Puna Geothermal Ventures ("PGV") and Hu Honua Bioenergy ("Hu Honua") facilities) are revised during the course of the RFP process. (Yes/No)	

IPP or Affiliate proposals:

- that contain a generation component (whether with or without an energy storage component) – complete the summary table items in part A below.
- that are standalone energy storage projects – complete the summary table items in part B below.

Self-Build proposals:

- that contain a generation component (whether with or without an energy storage component) – complete the summary table items in part C below.

³ Island Number (1 digit); Zone Number (1 digit); Section Number (1 digit); Plat Number (3 digits, add leading zeros if less than 3 digits); Parcel Number (3 digits, add leading zeros if less than 3 digits)

- that are standalone energy storage projects – complete the summary table items in part D below.

A. To be filled out by IPP or Affiliate proposals, IF the Project contains a Generation Component (With or Without an Energy Storage Component):

16	Project Generation Technology	
17	Net Energy Potential (NEP) Projection for the Facility (MWh)	
18	Lump Sum Payment (\$/Year)	
19	Price for Purchase of Electric Energy, if any (\$/MWh)	
20	Incremental cost required to enable Black Start, if any and if applicable (\$)	
21	Does Project include an Energy Storage Component? (Yes/No)	
If the Project includes an Energy Storage Component:		
22	Project Energy Storage Technology	
23	Energy Storage Capability for the Facility (MW and MWh)	
24	Is the Project capable of claiming the Federal Investment Tax Credit (ITC)? (Yes/No)	
25	If the Project is capable of claiming the Federal ITC, what percentage of grid charging of the energy storage system is the Project designed for during the ITC recapture period?	
26	If the Project is capable of claiming the Federal ITC, is the Project capable of being 100% charged from the grid after the ITC recapture period? (Yes/No)	
27	If the Project is not capable of claiming the Federal ITC, is the Project capable of being 100% charged from the grid from the GCOD? (Yes/No)	
32	Does the Project include Contingency Storage? (Yes/No)	
33	If the Project includes Contingency Storage, specify the amount (MW)	
34	Portion of Lump Sum Payment attributable to Contingency Storage (\$/year)	

B. To be filled out by IPP or Affiliate proposals, IF the Project is for Standalone Energy Storage:

22	Project Energy Storage Technology	
23	Energy Storage Capability for the Facility (MW and MWh)	
18	Lump Sum Payment (\$/Year)	
20	Incremental cost required to enable Black Start, if any (\$)	
27	Is the Project capable of being 100% charged from the grid from the GCOD? (Yes/No)	

C. To be filled out by Self-Build Option proposals, IF the Project contains a Generation Component (With or Without an Energy Storage Component):

16	Project Generation Technology		
17	Net Energy Potential (NEP) Projection for the Facility (MWh)		
20	Incremental cost required to enable Black Start, if any and if applicable (\$)		
21	Does Project include an Energy Storage Component? (Yes/No)		
If the Project includes an Energy Storage Component:			
22	Project Energy Storage Technology		
23	Energy Storage Capability for the Facility (MW and MWh)		
24	Is the Project capable of claiming the Federal Investment Tax Credit (ITC)? (Yes/No)		
25	If the Project is capable of claiming the Federal ITC, what percentage of grid charging of the energy storage system is the Project designed for during the ITC recapture period?		
26	If the Project is capable of claiming the Federal ITC, is the Project capable of being 100% charged from the grid after the ITC recapture period? (Yes/No)		
27	If the Project is not capable of claiming the Federal ITC, is the Project capable of being 100% charged from the grid from the GCOD? (Yes/No)		
32	Does the Project include Contingency Storage? (Yes/No)		
33	If the Project includes Contingency Storage, specify the amount (MW)		
29	Year (YYYY)	Project Capital Cost (\$)	Extend the table for questions 29, 30, 31 and 35 for as many years as needed.
30	Year (YYYY)	O&M Cost (\$)	
31	Year (YYYY)	Annual Revenue Requirement (\$)	
35	Year (YYYY)	Contingency Storage portion of Annual Revenue Requirement (\$)	

D. To be filled out by Self-Build Option proposals, IF the Project is for Standalone Energy Storage:

16	Project Energy Storage Technology		
20	Incremental cost required to enable Black Start, if any (\$)		
23	Energy Storage Capability for the Facility (MW and MWh)		
27	Is the Project capable of being 100% charged from the grid from the GCOD? (Yes/No)		
29	Year (YYYY)	Project Capital Cost (\$)	Extend the table for questions 29, 30, and 31 for as many years as needed.
30	Year (YYYY)	O&M Cost (\$)	
31	Year (YYYY)	Annual Revenue Requirement (\$)	

2.1 REQUIRED FORMS ACCOMPANYING PROPOSAL PDF

The following forms must accompany each proposal, must be attached to the Proposal PDF, and uploaded via the “2. Upload Documents” tab:

- Document signed by a representative for the Proposer **authorizing the submission** of the Proposal
- Fully executed Stage 2 **Mutual Confidentiality and Non-Disclosure Agreement** (Appendix E to the RFP, may be downloaded from the “1. Download Documents” tab in the Electronic Procurement Platform)
- **Certificate of Good Standing** for the Proposer (a Certificate of Vendor Compliance for the Proposer may be provided in lieu of a Certificate of Good Standing)
- **Federal and State tax clearance certificates** for the Proposer (a Certificate of Vendor Compliance for the Proposer may be provided in lieu of Federal and State tax clearance certificates)
- **Certification of Counsel for Proposer**, if applicable. (See Appendix B Attachment 1)
- Completed applicable **Interconnection Requirement Study Data Request form** for the proposed technology and, **project single line diagram(s). Models for equipment and controls, list(s)** identifying components and respective files (for inverters and power plant controller), and **complete documentation with instructions** as specified in the Data Request form shall be submitted within the respective timeframes specified in Section 5.1 of the RFP.⁴ (See Section 2.11.1 below)
- [For Self-Build Only] **Self-Build Option Team Certification Form**. See Appendix G Attachment 1.
- [For Self-Build Only] **Revenue Requirements Worksheets** that support the annual revenue requirements estimates shall be submitted. A starter revenue requirements template file can be requested by the Self-Build Team via email to the RFP Email Address or through the PowerAdvocate Messaging function once the RFP event opens. The revenue requirements worksheets submitted will be modified to reflect the details of the Project’s Proposal. All assumptions used will be reflected in an assumptions input tab.

2.2 PROPOSAL SUMMARY/CONTACT INFORMATION

2.2.1 Provide a **primary point of contact** for the Proposal being submitted:

- Name
- Title
- Mailing Address
- Phone Number
- Email Address

2.2.2 **Executive Summary of Proposal.** The executive summary must include an approach and description of the important elements of the Proposal, including additional descriptions for each minor variation to the Proposal being submitted. Refer to Section 1.8.2 and 1.8.3 of the RFP for an explanation of minor variations allowed. If variations are proposed, a **table summarizing the differences among the variations shall be included.**

⁴ If the Models, lists, respective files and complete documentation are not submitted with the Proposal upload, they shall be submitted via PowerAdvocate’s Messaging as attachments within the respective timeframes specified in Section 5.1 of the RFP.

2.2.3 **Pricing information.** Pricing information must be filled out in the Section 2.0 Proposal Summary Table above. If variations are proposed, each variation's pricing summary must be identified in a similar pricing table in Sections 3.2, 3.3, 3.4, etc. as applicable. Provide any pricing information only in those table sections – do not embed pricing information in any other portion of the Proposal PDF.

2.2.4 Provide a **high-level overview of the proposed Facility**, including at a minimum the following information:

- Facility Generation Size (MW_{AC} and MW_{DC})
- Net Maximum Output Capacity of the Facility at the Point(s) of Interconnection (MW_{AC})
- Identified Available Hosting Capacity of the Transmission-level Circuit Facility Interconnecting to (MW_{AC})

For projects that include a generation component:

- Technology Type
- Number of Generators
- Rated Output of each Generator
- Generator Facility Design Characteristics
- Fuel Source for Generation

For stand-alone storage projects or generation projects that include a storage component:

- Technology Type (i.e. lithium ion battery)
- Discharge Duration (hours)
- Storage Capacity (i.e. amount of energy released to fully discharge and amount of energy required to fully charge, in MW and MWh)
- Operational Limitations, such as, but not limited to: number of charge/discharge cycles per day-month-year (see the energy discharge requirement in Section 1.2.12 and 13 of the RFP).
- Minimum and Maximum Operational Ranges, such as minimum and maximum required state of charge
- Round Trip Efficiency at rated power measured at the Point of Interconnection (i.e. discharge energy divided by charge energy, expressed as a percentage)
- Round Trip Efficiency using full duty cycle for a fixed duration measured at the Point of Interconnection (%)
- For generation coupled with energy storage, described the Allowed Percentage of Storage Component's charging that can come from the System Grid, if any, and any conditions of charging (when, percentage of annual total energy input, etc.)

2.3 FINANCIAL

Provide the following financial information identified below.

2.3.1 Identification of Equity Participants

2.3.1.1 Who are the **equity participants** in the Project (or the equity partners' other partners)?

2.3.1.2 Provide an **organizational structure** for the Proposer including any general and limited partners and providers of capital that identifies:

- Associated responsibilities from a financial and legal perspective
- Percentage interest of each party

2.3.2 Project Financing

2.3.2.1 **How will the Project be financed** (including construction and term financing)? Address at a minimum:

- The Project's projected financial structure
- Expected source of debt and equity financing

2.3.2.2 [For IPP and Affiliate Proposals] Identify **estimated development and capital costs** for, at a minimum:

- Equipment
 - Identify the manufacturer and model number for all major equipment
- Construction
- Engineering
- Seller-Owned Interconnection Facilities
- Company-Owned Interconnection Facilities
- Land
- Annual O&M

[For Self-Build Only] Identify all **estimated development and capital costs** for, at a minimum:

- Facility (including any generation and storage components)
- Outside Services
- Interconnection
- Overhead Costs
- Allowance for Funds Used During Construction
- Annual O&M

2.3.2.3 Discuss and/or provide **supporting information on any project financing guarantees**.

2.3.2.4 Describe any **written commitments obtained from the equity participants**.

2.3.2.5 Describe any **conditions precedent to project financing**, and the Proposer's plan to address them, other than execution of the Power Purchase Agreement or any other applicable project agreements and State of Hawaii Public Utilities Commission approval of the Power Purchase Agreement and other agreements.

2.3.2.6 Provide any **additional evidence to demonstrate that the Project is financeable**.

2.3.3 Project Financing Experience of the Proposer

Describe **the project financing experience of the Proposer** in securing financing for projects of a similar size (i.e., no less than two-thirds the size) and technology as the one being proposed including the following information for any referenced projects:

- Project Name
- Project Technology
- Project Size
- Location
- Date of Construction and Permanent Financing
- Commercial Operations Date
- Proposer's Role in Financing of the Project
- Off-taker
- Term of the Interconnection Agreement
- Financing Structure
- Major Pricing Terms
- Name(s) of Finance Team Member(s); Time (i.e., years, months) worked on the project and Role/Responsibilities

2.3.4 Evidence of the Proposer's Financial Strength

2.3.4.1 Provide **copies of the Proposer's audited financial statements** (balance sheet, income statement, and statement of cash flows):

- Legal Entity
 - Three (3) most recent fiscal years
 - Quarterly report for the most recent quarter ended
- Parent Company
 - Three (3) most recent fiscal years
 - Quarterly report for the most recent quarter ended

2.3.4.2 Provide the **current credit ratings** for the Proposer (or Parent Company, if not available for Proposer), affiliates, partners, and credit support provider:

- Standard & Poor's
- Moody's
- Fitch

2.3.4.3 Describe any **current credit issues** regarding the Proposer or affiliate entities raised by rating agencies, banks, or accounting firms.

2.3.4.4 Provide any **additional evidence that the Proposer has the financial resources and financial strength** to complete and operate the Project as proposed.

2.3.5 Provide evidence that the Proposer can provide the required securities

2.3.5.1 Describe the Proposer's **ability (and/or the ability of its credit support provider) and proposed plans to provide the required securities** including:

- Irrevocable standby letter of credit
- Sources of security
- Description of its credit support provider

2.3.6 Disclosure of Litigation and Disputes

Disclose any **litigation, disputes, and the status of any lawsuits or dispute resolution** related to projects owned or managed by the Proposer or any of its affiliates

2.4 CONTRACT EXCEPTIONS AND FINANCIAL COMPLIANCE

2.4.1 If Proposers elect to propose modifications to the Model PPA or Model ESPPA, **provide a Microsoft Word red-line version of the Model PPA or Model ESPPA** identifying specific proposed modifications to the model language that the Proposer is agreeable to and a detailed explanation and supporting rationale for each modification. General comments, drafting notes and footnotes such as “parties to discuss” are unacceptable and will be considered non-responsive.

Proposers that do not upload redlines of the applicable PPA with their Proposal submission will be deemed to have accepted the model PPA in its entirety.

2.4.2 State to the best of the Proposer’s knowledge: Will the Project result in **consolidation** of the Developer entity’s finances onto the Company’s financial statements under FASB 810. **Provide supporting information** to allow the Company to verify such conclusion.

2.5 SITE CONTROL

2.5.1 The Proposal must demonstrate that the Proposer has Site Control for all real property required for the successful implementation of a specific Proposal at a Site not controlled by the Company, including any Interconnection Facilities for which the Proposer is responsible. In addition, developmental requirements and restrictions such as zoning of the Site and the status of easements must be identified. **Provide documentation set forth in RFP Section 4.3** to prove Site Control.

2.5.2 Provide a **map of the Project site** that clearly identifies:

- Location of the parcel on which the site is located
- Tax map key number (9-digit format: Island Number (1 digit), Zone Number (1 digit), Section Number (1 digit), Plat Number (3 digits, add leading zeros if less than 3 digits), Parcel Number (3 digits, add leading zeros if less than 3 digits)
- Site boundaries (if the site does not cover the entire parcel)
- Total acreage of the site
- Point(s) of Interconnection
- Relationship of the site to other local infrastructure

2.5.3 Provide a **site layout plan** which illustrates:

- Proposed location of all equipment
- Proposed location of all facilities on the site, including any proposed line extensions

2.5.4 Describe the **Interconnection route** and include:

- Site sketches of how the facility will be interconnected to the Company’s System (above-ground and/or underground)
- Identify the approximate latitude and longitude of the proposed Point of Interconnection, in decimal degrees format, to six (6) decimal places.

- Description of the rationale for the interconnection route

2.5.5 Identify **any rights-of-way or easements** that are required for access to the site or for interconnection route:

- Describe the status of rights-of-way or easement acquisition
- Describe the plan for securing the necessary rights-of-way or easement, including the proposed timeline

2.6 ENVIRONMENTAL REVIEW, PERMITTING PLAN, ENVIRONMENTAL COMPLIANCE/IMPACTS

2.6.1 Describe your **overall land use and environmental permits and approvals strategy** and approach to obtaining successful, positive results from the agencies and authorities having jurisdiction, including:

- Explanation of the conceptual plans for siting
- Studies/assessments
- Permits and approvals
- Gantt format schedule which identifies the sequencing of permit application and approval activities and critical path. (Schedule must be in MM/DD/YY format.)

2.6.2 Discuss the **City Zoning and State Land Use Classification**:

- Identify present and required zoning and the ability to site the proposed Project within those zoning allowances.
- Identify present and required land use classifications and the ability to site the proposed Project within those classifications.
- Provide evidence of proper zoning and land use classifications for selected site and interconnection route.
- If changes in the above are required for the proposed Project, provide a plan and timeline to secure the necessary approvals.

2.6.3 Identify all required discretionary and non-discretionary **land use, environmental and construction permits, and approvals** required for development, financing, construction, and operation of the proposed Project, including but not limited to zoning changes, Environmental Assessments, and/or Environmental Impacts Statements.

Provide a **listing of such permits and approvals** indicating:

- Permit Name
- Federal, State, or Local agencies and authorities having jurisdiction over the issuance
- Status of approval and anticipated timeline for seeking and receiving the required permit and/or license
- Explanation of your basis for the assumed timeline
- Explain any situation where a permit or license for one aspect of the Project may influence the timing or permit of another aspect (e.g. a case where one permit is contingent upon completion of another permit or license), if applicable.
- Explain your plans to secure all permits and approvals required for the Project.

2.6.4 Provide a **preliminary environmental assessment of the site** (including any pre-existing environmental conditions) and potential short- and long-term **impacts** associated with, or resulting from, the proposed Project – including direct, indirect, and cumulative impacts associated with development, construction, operation, and maintenance of the proposed Project in every area identified below. Discuss if alternatives have been or will be considered. The assessment shall also include Proposer’s short- and long-term plans to mitigate such impacts and explanation of the mitigation strategies for, but not limited to, each of the major environmental areas as presented below:

- Natural Environment
 - Air quality
 - Biology (Natural habitats and ecosystems, flora/fauna/vegetation, and animals, especially if threatened or endangered)
 - Climate
 - Soils
 - Topography and geology
- Land Regulation
 - Land Uses, including any land use restrictions and/or pre-existing environmental conditions/contamination
 - Flood and tsunami hazards
 - Noise
 - Roadways and Traffic
 - Utilities
- Socio-Economic Characteristics
- Aesthetic/Visual Resources
- Solid Waste
- Hazardous Materials
- Water Quality
- Public Safety Services (Police, Fire, Emergency Medical Services)
- Recreation
- Potential Cumulative and Secondary Impacts

2.6.5 Provide a **decommissioning plan**, including:

- Developing and implementing program for recycling to the fullest extent possible, or otherwise properly disposing of installed infrastructure, if any, and
- Demonstrating how restoration of the Site to its original ecological condition is guaranteed in the event of default by the Proposer in the applicable Site Control documentation.

2.7 CULTURAL RESOURCE IMPACTS

2.7.1 Provide a **plan to address the below requirements** as they pertain to the Project Site and interconnection route including the status of any consultant/s with expertise in this field that have been identified and/or contracted with, and documentation of any assessments or work that has been planned or performed to date. Identify any cultural, historical or natural resources in the area in question. For any impacts identified to the categories listed below, provide a mitigation strategy and the expected impact on the Project schedule. Detail the potential impacts of the Proposal on cultural resources in the short- and long-term and the Proposer’s plan to mitigate such impacts. Proposers must provide as much information as possible to allow the Company to understand the considerations.

- Archaeological Resources
- Cultural Practices and Resources

2.8 COMMUNITY OUTREACH

2.8.1 Provide a **detailed Community Outreach Plan** to work with and inform neighboring communities and stakeholders and to provide them timely information during all phases of the Project. The plan shall address, but not be limited to, the following items:

- Project description
- Community scoping
- Project benefits
- Government approvals
- Development process
- Identification of communities and other stakeholders that may be affected by the proposed Project:
 - How will they be affected?
 - What mitigation strategies will the Proposer implement?
- Comprehensive communication strategy with affected communities and the general public regarding the proposed Project:
 - Describe frequency of communication
 - Provide source of information
 - Identify communication outlets
 - Describe opportunities, if any for affected communities and general public to provide the developer with feedback and comments on the proposed Project

2.8.2 Provide any **documentation of local community support or opposition** including any letters from local organizations, newspaper articles, or communications from local officials.

2.8.3 Provide a **description of community outreach efforts** already taken or currently underway, including the names of organizations and stakeholders contacted about the proposed Project.

2.8.4 Describe any anticipated or negotiated investment in the community and other **community benefits** that the Proposer proposes to provide in connection with the Project, along with an estimated value of the community benefits in dollars (including the cost to Proposers providing the benefits and supporting details on how those costs and benefits were derived).

2.9 OPERATIONS AND MAINTENANCE (O&M)

2.9.1 To demonstrate the long-term operational viability of the proposed Project, describe the **planned operations and maintenance**, including:

- Operations and maintenance funding levels, annually, throughout the term of the contract.
- Description of the operational requirements by frequency (daily, weekly, monthly, yearly, as-necessary, run hour interval) and maintenance requirements by frequency (daily, weekly, monthly, yearly, as-necessary, run hour interval).
- A discussion of the staffing levels proposed for the Project and location of such staff. If such staff is offsite, describe response time and ability to control the Project remotely.
- Technology specific maintenance experience records.
- Identification of any O&M providers.
- The expected role of the Proposer (Owner) or outside contractor.
- Scheduling of major maintenance activity.

- Plan for testing equipment.
- Estimated life of Generation and/or Storage Facilities and associated Interconnection Facilities.
- Safety plan, including historical safety records with environmental history records, violations, and compliance plans.
- Security plan.
- Site maintenance plan.
- Substation equipment maintenance plan.

2.9.2 State whether the Proposer would **consider 24-hour staffing**. Explain how this would be done.

2.9.3 Describe the **Proposer's contingency plan**, including the Proposer's mitigation plans to address failures. Such information should be described in the Proposal to demonstrate the Project's reliability with regard to potential operational issues.

2.9.4 Describe if the Proposer will **coordinate their maintenance schedule** for the Project with the Company's annual planned generation maintenance. See Article 5 of the model RDG PPA.

2.9.5 Describe the **status of any O&M agreements or contracts** that the Proposer is required to secure. Include a discussion of the Proposer's plan for securing a long-term O&M contract.

2.9.6 Provide **examples of the Proposer's experience** with O&M services for other similar projects.

2.10 PERFORMANCE STANDARDS

2.10.1 Design and operating information. Provide a **description of the project design**. Description shall include:

- Configuration description
- Overview of the Facility Control Systems – central control and inverter- or resource-level control
- Diagrams approved by a Professional Electrical Engineer registered in the State of Hawai'i, indicated by the presence of the Engineer's Professional seal on all drawings and documents. Including but not limited to:
 - A single-line diagram, relay list, trip scheme and settings of the generating facility, which identifies the Point of Interconnection, circuit breakers, relays, switches, synchronizing equipment, monitoring equipment, and control and protective devices and schemes.
 - A three-line diagram which shows the Point of Interconnection, potential transformer (PT) and current transformer (CT) ratios, and details of the generating facility configuration, including relays, meters and test switches.

2.10.1.1 For Generation Facilities, provide the projected **hourly annual energy potential production profile of the Facility**⁵ (24 hours x 365 days, 8760 generation profile) for the provided RFP NEP Projection.

⁵ The projected hourly annual energy production profile is the projected output from the generating facility without curtailment and before any energy is directed to an energy storage component, if one will be provided.

2.10.1.2 Provide the **sample rate of critical telemetry** (i.e. frequency and voltage) based on inputs to the facility control systems.

2.10.1.3 Provide a description of the Facility's **capability to be grid-forming and have black start capability**. For standalone energy storage or energy storage coupled with generation facilities, if black start is not a capability already enabled, provide a description of the modifications to the Facility necessary to enable black start and any additional cost to include that capability (within the summary tables of Section 2.0).

2.10.2 **Capability of Meeting Performance Standards.** The proposed Facility must meet the performance attributes identified in this RFP and the Performance Standards identified in the applicable RDG PPA or the ESPPA. Provide **confirmation that the proposed Facility will meet the requirements identified in the Model PPA** or provide clarification or comments about the Facility's ability to meet the performance standards. Proposals should include sufficient documentation to support the stated claim that the Facility will be able to meet the Performance Standards. The Proposal should include information required to make such a determination in an organized manner to ensure this evaluation can be completed within the evaluation review period.

2.10.3 **Reactive Power Control:** Provide the facility's ability to meet the Reactive Power Control capabilities, including Voltage Regulation at the point of interconnection, required in the Performance Standards, including contribution from the inverters of generation and/or storage and means of coordinating the response. Provide the inverter capability curve(s). Confirm ability to provide reactive power at zero active power.

2.10.4 **Ramp Rate** for Generation Facilities: Confirm the ability to meet the ramp rate requirement specified in the Model PPA.

2.10.5 **Undervoltage ride-through:** Provide the facility's terminal voltage level(s) and elapsed time at which the facility will disconnect from the utility system during the disturbance, if any. Confirm the ability to meet ride-through requirements and include supporting documentation regarding inverter design, control parameters, etc.

2.10.6 **Overvoltage ride-through:** Provide the facility's terminal voltage level(s) and elapsed time at which the facility will disconnect from the utility system during the disturbance, if any. Confirm the ability to meet ride-through requirements and include supporting documentation regarding inverter design, control parameters, etc.

2.10.7 **Transient stability ride-through:** Provide the facility's ability to stay online during Company System: (1) three-phase fault located anywhere on the Company System and lasting up to __ cycles; and (2) a single line to ground fault located anywhere on the Company System and lasting up to __ cycles. Provide the Facility's ability to withstand subsequent events.

2.10.8 **Underfrequency ride-through:** Provide the facility's terminal frequency level(s) and elapsed time at which the facility will disconnect from the utility system during the disturbance, if any. Confirm the ability to meet ride-through requirements and include supporting documentation regarding inverter design, control parameters, etc.

2.10.9 **Overfrequency ride-through:** Provide the facility's terminal frequency level(s) and elapsed time at which the facility will disconnect from the utility system during the disturbance, if any. Confirm the ability to meet ride-through requirements and include supporting documentation regarding inverter design, control parameters, etc.

2.10.10 **Frequency Response:** Provide the facility's frequency response characteristics as required by the Model PPA, including time of response, tunable parameters, alternate frequency response modes and means of implementing such features.

2.10.11 **Auxiliary Power Information:** Proposer must provide the maximum auxiliary power requirements for:

- Start-up
- Normal Operations (from generator)
- Normal Operating Shutdown
- Forced Emergency Shutdown
- Maintenance Outage

2.10.12 **Coordination of Operations:** Provide a description of the control facilities required to coordinate generator operation with and between the Company's System Operator and the Company's System.

- Include a description of the equipment and technology used to facilitate dispatch to the Company and communicate with the Company.
- Include a description of the control and protection requirements of the generator and the Company's System.

2.10.13 **Cycling Capability:** Describe the Facility's ability to cycle on/off and provide limitations.

2.10.14 **Active Power Control Interface:** Describe the means of implementing active power control and the Power Possible, including the contribution to the dispatch signal from paired storage, if any. Provide the Proposer's **experience** dealing with active power control, dispatch, frequency response, and ride-through.

2.10.15 Provide the details of the **major equipment** (i.e. batteries, inverters, battery management system), including, but not limited to, name of manufacturer, models, key metrics, characteristics of the equipment, and performance specifications.

2.10.16 **Energy Storage performance standards:** For stand-alone storage projects or generation projects that include a storage component, provide additional performance standard descriptions as follows:

- Number of cycles per day, or equivalent MWh storage output for a full year
- Ramp Rate: Provide the Facility's ramp rate, which should be no more than 2 MW/minute for all conditions other than those under control of the Company System Operator and/or those due to desired frequency response.
- System Response Time – Idle to Design Maximum (minutes)
- Discharge Start-up time (minutes from notification)
- Charge Start-up time (minutes from notification)
- Start and run-time limitations, if any

- Ancillary Services provided, if any (i.e. Spinning Reserves, Non-Spinning Reserves, Regulation Up, Regulation Down, Black Start capability, other)

2.10.17 Provide the description and details of the **grid-charging capabilities of the Facility**. Include a description on the ability to control the charging source.

2.10.18 For contingency reserve storage projects or generation projects with a Contingency Storage component, provide a **description of the Facility’s ability to meet the Company’s contingency response needs**. The description should identify all assumptions and associated restrictions on the charging/discharging duty of the proposed contingency storage.

2.11 INTERCONNECTION REQUIREMENT STUDY

2.11.1 Provide the appropriate completed **Interconnection Requirement Study Data Request form** for the proposed technology with the Proposal submission. (The forms can be found in the “1. Download Documents” tab as Appx B Att 2 IRS Data Request Form (PV Generation), Appx B Att 3 IRS Data Request Form (Wind Generation) or Appx B Att 4 IRS Data Request Form (Sync Generation) MSEXcel files.) Also provide all **project single line diagram(s)** with the Proposal submission. **Models for equipment and controls, list(s)** identifying components and respective files (for inverters and power plant controller), and **complete documentation with instructions** shall be submitted within the timeframes specified in Section 5.1 of the RFP.⁴ Proposers may also download the PSCAD model requirements memo labelled as Appx B Att 5 from the “1. Download Documents” tab also.

2.12 PROVEN TECHNOLOGY

2.12.1 Provide all supporting information for the Company to assess the **commercial and financial maturity of the technology** being proposed. Provide any supporting documentation that shows examples of projects that:

- Use the technology at the scale being proposed
- Have successfully reached commercial operations (for example, by submitting a PPA)
- Demonstrate experience in providing Active Power dispatch

2.13 EXPERIENCE AND QUALIFICATIONS

Proposers, its affiliated companies, partners, and/or contractors and consultants are required to demonstrate project experience and management capability to successfully develop and operate the proposed Project.

2.13.1 Provide an **organizational chart** for the Project that lists the project participants and identifies the management structure and responsibilities.

- For each of the project participants (including the Proposer, partners, and proposed contractors), fill out the table below and provide statements that list the specific experience of the firm in: financing, designing, constructing, interconnecting, owning, operating, and maintaining renewable energy generating or storage facilities, or other projects of similar size and technology, and
- Provide any evidence that the project participants have worked jointly on other projects.

Participant Name:	EXPERIENCE:						
	Financing	Designing	Constructing	Interconnecting	Owning	Operating	Maintaining
1.							
2.							
3.							
...							

2.13.2 Identify those **member(s) of the team** the Proposer is submitting to meet the experience Threshold Requirement and demonstrate the member(s) firm commitment to provide services to the Proposer.

2.13.3 Identify those **members of the team with experience and qualifications**, including affiliates, and their principal personnel who will be involved in the project contracting to sell and deliver energy. If the Proposer consists of multiple parties, such as joint ventures or partnerships, provide this information for each party, clearly indicating the proposed role of each party, including an ownership chart indicating direct and indirect ownership, and percentage interests in the partnership or joint venture.

2.13.4 Provide a **management chart** which lists the key personnel dedicated to this Project and provide **biographies / resumes** of the key personnel, including position, years of relevant experience, and similar project experience. Provide specifics as they relate to financing of renewable energy projects. Identify architects and engineers or provision to provide same that are licensed to practice in the State of Hawai'i.

2.13.5 Provide a **listing in the table format below, of all renewable energy generation or energy storage projects** the Proposer has successfully developed or that are currently under construction. Describe the Proposer's role and responsibilities associated with these projects (lead developer, owner, investor, etc.). Provide the following information as part of the response:

Project Name	Location (City, State)	Technology (wind, PV, hydro, plus storage, etc.)	Size (MW/ MWh)	Commercial Operation Date	Offtaker (if applicable)	Role & Responsibilities
1.						
2.						
3.						
...						

2.14 STATE OF PROJECT DEVELOPMENT AND SCHEDULE

2.14.1 Provide a **project schedule in GANTT chart format** with complete **critical path activities** identified for the Proposal from the Notice of Selection of the Proposal for contract negotiation to the start of Commercial Operations.

- The **schedule** must include:
 - Interconnection Requirement Study (IRS) assumptions

- Anticipated contract negotiation period assumptions
- Regulatory assumptions
- Anticipated submittal and approval dates for permitting (including but not limited to environmental and archaeological compliance)
- Siting and land acquisition
- Cultural Resource implications and mitigation activities
- Community outreach and engagement activities
- Energy resource assessment
- Financing
- Engineering
- Procurement
- Facility construction including construction management events
- Applicable reporting milestone events specified in the Model PPA
- Testing
- Interconnection (including engineering, procurement, and construction)
- Commercial Operations Date
- All other important elements outside of the direct construction of the Project
- For each project element, list the start and end date (must be in MM/DD/YY format), and include predecessors to clearly illustrate schedule dependencies and durations.
- Proposers must also list and describe critical path activities and milestone events, particularly as they relate to the integration and coordination of the project components and the Company's Electric System. Proposers must ensure that the schedule provided in this section is consistent with the milestone events contained in the PPA and/or other agreements.

2.14.2 Describe the **construction execution strategy** including:

- Identification of contracting/subcontracting plans
- Modular construction
- Safety plans⁶
- Quality control and assurance plan
- Labor availability
- Likely manufacturing sites and procurement plans
- Similar projects where these construction methods have been used by the Proposer.

2.14.3 Provide a description of any **project activities that have been performed to date**.

2.14.4 Explain how you plan to reach **safe harbor milestones** (if applicable) and **guaranteed commercial operations**, including durations and dependencies which support this achievement.

⁶ A document that describes the various safety procedures and practices that will be implemented on the Project and how applicable safety regulations, standards, and work practices will be enforced on the Project.

3.0 MINOR PROPOSAL VARIATIONS

Proposers submitting minor variations to a Proposal must provide the **details of each variation in the below section(s)**. In each proposal variation section below, Proposers must add the applicable tables from Section 2.0 Proposal Summary of this Appendix B. The information in these tables should reflect the information for the variation being proposed. Additionally, Proposers must identify all changes to the information provided in response to Sections 2.1 through 2.14 of this Appendix B for the proposal variation. If differences are not identified for the Section 2.0 Proposal Summary or a particular section in Sections 2.1 through 2.14, the Company will assume that the information contained in the base Proposal also applies to the proposal variation.

Note: Section 2.2.2 above requires a table summarizing the differences among the variations, if variations are proposed.

3.1 PROPOSAL VARIATION 1 (BASE VARIATION)

N/A (All information for the original proposal is identified in Sections 2.0 through 2.14 above).

3.2 PROPOSAL VARIATION 2 (AS NECESSARY)

Identified changes to Sections 2.0 through 2.14, as required for each variation.

3.3 PROPOSAL VARIATION 3 (AS NECESSARY)

Identified changes to Sections 2.0 through 2.14, as required for each variation.

3.4 PROPOSAL VARIATION 4 (AS NECESSARY)

Identified changes to Sections 2.0 through 2.14, as required for each variation.

3.5 PROPOSAL VARIATION 5 (AS NECESSARY AND ALLOWED)

Identified changes to Sections 2.0 through 2.14, as required for each variation.

3.6 PROPOSAL VARIATION 6 (AS NECESSARY AND ALLOWED)

Identified changes to Sections 2.0 through 2.14, as required for each variation.

3.7 PROPOSAL VARIATION 7 (AS NECESSARY AND ALLOWED)

Identified changes to Sections 2.0 through 2.14, as required for each variation.

3.8 PROPOSAL VARIATION 8 (AS NECESSARY AND ALLOWED)

Identified changes to Sections 2.0 through 2.14, as required for each variation.

Certification of Counsel for Proposer
Hawaiian Electric Company, Inc., Maui Electric Company, Ltd, and Hawai'i Electric Light
Company, Inc.

Variable Renewable Dispatchable Generation and Energy Storage Stage 2 RFP

Pursuant to Section 1.7.3 of Hawaiian Electric Company, Inc., Hawai'i Electric Light Company, Inc. and Maui Electric Company, Limited's (each a "Company" and collectively, the "Companies") Request For Proposals for Variable Renewable Dispatchable Generation and Energy Storage ("RFP"), the Companies may require legal counsel who represent multiple unaffiliated proposers to sign a certification that they have not shared confidential information obtained through the representation of one proposer with any other unaffiliated proposer.

Accordingly, by signing below, I hereby acknowledge, agree and certify that:

(1) in connection with the RFP, I represent the following company that has submitted a proposal(s) for the RFP: _____ ("Proposer");

(2) irrespective of any proposer's direction, waiver or request to the contrary, I will not share a proposer's confidential information or the Company's confidential information associated with such proposer, including, but not limited to, a proposer's or Company's negotiating positions, with third parties unaffiliated with Proposer (by contract or organizational structure), including other proposers responding to the RFP;

(3) the Companies may rely on this certification for purposes of the RFP; and

(4) at the conclusion of power purchase agreement negotiations, if any, the Company may require me to sign a certificate certifying that I have not shared a proposer's confidential information or the Company's confidential information associated with such proposer, including, but not limited to, a proposer's or Company's negotiating positions, with third parties unaffiliated with Proposer (by contract or organizational structure), including other proposers responding to the RFP.

Name (print)

Law Firm (if applicable)

Signature

Date

Section 1.7.3 of the RFP provides in relevant part that:

In submitting a Proposal in response to this RFP, each Proposer certifies that the Proposal has been submitted in good faith and without fraud or collusion with any other unaffiliated person or entity. The Proposer shall acknowledge this in the Response Package submitted with its Proposal. Furthermore, in executing the NDA provided as Appendix E, the Proposer agrees on behalf of its Representatives (as defined in the NDA) that the Company's negotiating positions will not be shared with other Proposers or their respective Representatives.

In addition, in submitting a Proposal, a Proposer will be required to provide Company with its legal counsel's written certification in the form attached as Appendix B Attachment 1 certifying in relevant part that irrespective of any proposer's direction, waiver, or request to the contrary, that the attorney will not share a proposer's confidential information associated with such proposer, including, but not limited to, a proposer's or Company's negotiating positions, with third parties unaffiliated with Proposer (by contract or organizational structure), including other proposers

responding to the RFP. If legal counsel represents multiple unaffiliated proposers whose
Proposals are selected for the Final Award Group, such counsel will also be required to submit a
similar certification at the conclusion of power purchase agreement negotiations that he or she
has not shared a proposer's confidential information or the Company's confidential information
associated with such proposer, including but not limited to, a proposer's or Company's
negotiating positions, with third parties unaffiliated with such proposer (by contract or
organizational structure), including other proposers responding to the RFP.

**Interconnection Requirement Study - Data Request
FOR PV GENERATION**

PROJECT: _____

DATE: _____

(Nonexclusive Preliminary List)

ALL ITEMS ARE REQUIRED AND ALL RESPONSES MUST BE FILLED UNLESS NOT APPLICABLE.

	Response
1) Please provide a plan map of the Non-Utility Generation (NUG) facility. Please indicate the interconnection point to the HECO system.	
2) Please provide the following generation and load information for the NUG facility:	
a. Gross and net output of the facility	
b. Expected KW and KVAR loads including, but not limited to, generators' auxiliary load curve, process load(s) profile(s), etc.	
c. Expected minimum and maximum MW and MVAR "import from" AND "export to" HECO.	
3) Please provide Single-Line Diagram(s), Three-Line Diagram(s), and Protective Relay List & Trip Schedule for the generation and interconnection facilities:	
a. The Single-line diagram(s) and Three-line diagram (s) should include:	
i. For main and generator step up transformer(s), please show:	
• Transformer voltage and MVA ratings.	
• Transformer impedance(s).	
• Transformer winding connections and grounding. If neutrals are grounded through impedance, please show the impedance value.	
ii. The protective relaying and metering for the generators, transformers, buses, and all other main substation equipment.	
iii. For the potential transformers, please indicate the type, quantity, ratio, and accuracy rating.	
iv. For the current transformers, please indicate the type, quantity, ratio, and accuracy rating, and thermal rating factor.	
v. Auxiliary power devices (e.g. capacitors, reactors, storage systems, etc.) and their rating(s); additional inquiries may be made to obtain technical data for these devices.	
vi. For the interconnection / tie lines (overhead or underground) and the plant's generation system, please provide the following, as applicable:	
• Installation details such as cross-section(s), plan and profiles, etc.	
• Conductor data such as size, insulation, length etc.	
• Continuous and emergency current ratings.	
• Voltage rating (nominal and maximum KV).	
• BIL rating.	
• Positive, negative, and zero-sequence impedances (resistance, reactance, and susceptance)	
• Capacitance or charging current.	
• Short-circuit current capability.	
vii. Include station power for facility and all applicable details.	
viii. All applicable notes pertaining to the design and operation of the facility.	
b. The Protective relay list & trip schedule should list the protected equipment; the relay description, type, style number, quantity, ANSI Device No., and range; and the breaker(s)/switching device(s) tripped, for both the generator protection and the interconnection facilities protection.	
c. Please provide both a paper and an electronic version (e.g. dgn, dxf, or pdf) of the single-line diagram(s) and the protective relay list & trip schedule.	
d. Single-line diagrams should be provided for both the generation plant and the interconnection substation.	

**Interconnection Requirement Study - Data Request
FOR PV GENERATION**

Updated 7/16/2018

PROJECT: _____
DATE: _____

(Nonexclusive Preliminary List)

ALL ITEMS ARE REQUIRED AND ALL RESPONSES MUST BE FILLED UNLESS NOT APPLICABLE.

	Response
4) For the PV Inverter Based Generating Facility, please provide the following data:	
a. Inverter manufacturer, Type, Size, Impedances. Attach copy of inverter data sheet.	
b. Power Factor Range Capability	
c. Inverter Reactive Power Capability Curve	
d. Auxillary loads (P, Q, Power Factor)	
e. Ramp rates (up, down) Typical and Measured Proxy Data	
f. Inverter's Internal Isolation Transformer Grounding Method, if used (i.e. effectively grounded, resonant grounded, low inductance grounded, high-resistance grounded, low-resistance grounded, ungrounded). If the transformer is not solidly grounded, provide the impedance value for the grounding neutral and the impedance for the isolation transformer.	
g. Diagram for Inverter's internal isolation transformer	
h. Switching and service restoration practice	
i. Protection data (voltage ride-through and trip settings, frequency ride-through and trip settings etc.). Include setpoint and clearing time ranges for voltage and frequency settings.	
j. Details of filters etc. at Point of Interconnection	
k. Description of harmonic spectrum of inverter injection (order, magnitude)	
l. Description of PV inverter with respect to varying levels of solar irradiance	
5) Energy Storage System, if applicable	
a. Operation characteristics	
b. Voltage level	
c. Capacity (how long and how much can the battery support)	
d. Deployment strategy/schedule	
e. Energy storage system data sheet	
6) For the PV plant's collector system, please provide the following, as applicable:	
a. Conductor data such as size, insulation, etc.	
b. Continuous and emergency current ratings.	
c. Voltage rating (nominal and maximum kV).	
d. BIL rating.	
e. Positive, negative, and zero-sequence impedances (resistance, reactance, and susceptance).	
f. Capacitance or charging current.	
g. Short-circuit current capability.	

**Interconnection Requirement Study - Data Request
FOR PV GENERATION**

PROJECT: _____

DATE: _____

(Nonexclusive Preliminary List)

ALL ITEMS ARE REQUIRED AND ALL RESPONSES MUST BE FILLED UNLESS NOT APPLICABLE.

		Response
7)	<p>Please provide the following software models that accurately represent the Facility:</p> <p>a. Validated PSS/E load flow model up to the point of interconnection. The PSS/E model shall include the main transformer, collection system, generator step-up transformers, inverter systems, and any other components including capacitor banks, energy storage systems, DVAR, etc. An equivalent representation of the collection system, generator step-up transformers, and inverter systems is acceptable. Documentation on the model shall be provided.</p> <p>b. Validated PSS/E dynamic model for the inverter; and other components including energy storage system, DVAR, etc. if applicable. The inverter model shall include the generator/converter, electrical controls, plant-level controller, and protection relays. Generic and Detailed models shall be provided. Documentation on the model(s) shall be provided, including the PSS/E dyre file with model parameters.</p> <p>i. Generic models shall parameterize models available within the PSS/E standard model library.</p> <p>ii. Detailed models shall be supplied by the vendor/manufacturer as user-written models. The uncompiled source code for the user-written model shall be provided to ensure compatibility with future versions of PSS/E. In lieu of the uncompiled source code, a compiled object file and applicable library files shall be provided in PSS/E versions 33 AND 34 format. Updates of the object file compatible with future PSS/E versions must be provided as requested for the life of the project as written in the power purchase agreement. Documentation shall include the characteristics of the model, including block diagrams, values, names for all model parameters, and a list of all state variables.</p> <p>c. Validated PSCAD model of the inverter; and other components including energy storage system, DVAR, auxiliary plant controllers, etc. if applicable. Documentation on the model(s) shall be provided. Refer to PSCAD Technical Memo for model requirements.</p> <p>d. Overlaid plots validating the performance of the three dynamic models for a three-phase fault. Plots shall include voltage, real and reactive power, real and reactive current.</p> <p>e. Voltage plot validating the performance of inverter to meet the Companies' Transient Overvoltage (TROV-2) policy. Plot shall show the inverter trip and resulting voltage and current waveforms. Refer to Appendix E of Companies' Grid Supportive Utility-Interactive Inverter Qualification Requirements.</p> <p>f. Validated Aspen Oneliner short circuit model that accurately represents the facility (including energy storage system if applicable), and is valid for all faults conditions anywhere on the Utility system. Documentation on the model(s) shall be provided. (OTHERWISE SEE ADDITIONAL TABS FOR REQUIRED INFORMATION TO MODEL INVERTER)</p>	
8)	<p>For the main transformer and generator step-up transformers, please provide:</p> <p>a. Transformer voltage and MVA ratings, and available taps. Attach copy of transformer test report or data sheet</p> <p>b. The tap settings used.</p> <p>c. The LTC Control Scheme.</p> <p>d. Transformer winding connections and grounding used. If the transformer is not solidly grounded, provide the impedance value for the grounding method.</p> <p>e. Positive, negative, and zero sequence impedance values.</p>	
9)	<p>For the circuit breakers and fault-clearing switching devices, including the generator breakers, please provide:</p> <p>a. The voltage, continuous current and interrupting capability ratings.</p> <p>b. The trip speed (time to open).</p>	

**Interconnection Requirement Study - Data Request
FOR PV GENERATION**

Updated 7/16/2018

PROJECT: _____

DATE: _____

(Nonexclusive Preliminary List)

ALL ITEMS ARE REQUIRED AND ALL RESPONSES MUST BE FILLED UNLESS NOT APPLICABLE.

		Response
10)	For the power fuses, please provide:	
	a. The manufacturer, type, size, and interrupting capability.	
	b. The minimum melt and total clearing curves.	
11)	For the protective relaying, please provide:	
	a. Data for the CTs used with the relaying including the manufacturer, type of CT, accuracy class, and thermal rating factor.	
	b. Data for the PTs used with the relaying including the manufacturer, type of PT, voltage ratings, and quantity.	
12)	Please provide protective relay settings for existing and proposed generators, including but not limited to, reverse power, negative sequence, over and underfrequency, over and under voltage, volts per hertz, etc.	

Instructions:

Please fill in the data in the green blanks below

(Note: This does not include the internal isolation transformer, if used)

[1] Maximum rated output power = kVA

[2] Impedances in **Per Unit** based on kVA from [1]

	R	X
Subtransient =	<input type="text"/>	<input type="text"/>
Transient =	<input type="text"/>	<input type="text"/>
Synchronous =	<input type="text"/>	<input type="text"/>
Negative Sequence =	<input type="text"/>	<input type="text"/>
Zero Sequence =	<input type="text"/>	<input type="text"/>

[3] Neutral impedance (if any) in actual **Ohms**:

R	X
<input type="text"/>	<input type="text"/>

NOTE: These parameters should reflect the inverter response for all types of faults at any point on the electrical system to which the inverter is connected. This includes faults at the inverter output terminals, and also on the 138 kV transmission system. If the stated parameters do not cover this range, please state the adjustments needed to these parameters to accurately represent the inverter response across this range.

These parameters will be used to model the inverter in the Aspen Oneliner program as shown in the sample dialog box below:

Generating Unit Info

ID= Unit rating= MVA

Impedances (pu based on unit MVA)

Subtransient	<input type="text" value="0."/>	+j	<input type="text" value="0.1"/>	Fill
Transient	<input type="text" value="0."/>	+j	<input type="text" value="0.1"/>	
Synchronous	<input type="text" value="0."/>	+j	<input type="text" value="0.1"/>	
- sequence	<input type="text" value="0."/>	+j	<input type="text" value="0.15"/>	
o sequence	<input type="text" value="0."/>	+j	<input type="text" value="9999."/>	

Neutral Impedance (in actual Ohms)

<input type="text" value="0."/>	+j	<input type="text" value="0."/>
---------------------------------	----	---------------------------------

Scheduled generation. Enter MVAR for PQ buses only

MW=

MVAR=

P and Q limits (MW/ and MVAR)

Pmax=

Qmax=

Pmin=

Qmin=

Instructions:

Please fill in the data in the green blanks below

- [1] Internal open circuit voltage
 Magnitude = Per Unit
 Angle = Degrees
- [2] AC Output Current Limit = Amps

NOTE: These parameters should reflect the inverter response for all types of faults at any point on the electrical system to which the inverter is connected. This includes faults at the inverter output terminals, and also on the 138 kV transmission system. If the stated parameters do not cover this range, please state the adjustments needed to these parameters to accurately represent the inverter response across this range.

These parameters will be used to model the inverter in the Aspen Oneliner program as shown in the sample dialog box below:

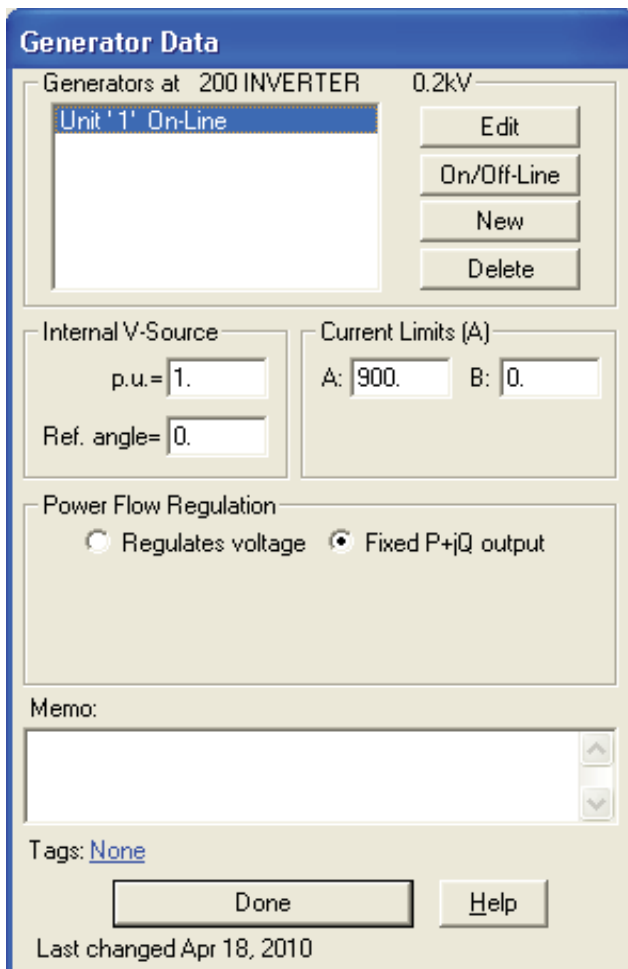

Instructions:

Please fill in the data in the green blanks below

(Note: This is not required if an internal isolation transformer is not used)

[1] Transformer rated power = kVA

[2] Winding Configuration
 Inverter Side = Delta/Wye
 Customer Side = Delta/Wye

[2] Impedances in **Per Unit** based on kVA
 Positive Sequence = R X
 Zero Sequence =

[3] Neutral impedance (if any) in actual **Ohms**:
 R X

These parameters will be used to model the inverter in the Aspen Oneliner program as shown in the sample dialog box below:

2-Winding Transformer Data

100 480 V TERM 0.48kV - 200 INVERTER 0.2kV

Name= Ckt ID= MVA1= MVA2= MVA3=

MVA base for per-unit quantities=

R= X=
 B=
 Ro= Xo=
 Bo=

480 V TERM 0.48 kV INVERTER 0.2 kV

Tap kV= Tap kV=
 G1*= G2*=
 B1*= B2*=
 G10*= G20*=
 B10*= B20*=

Neutral grounding Z (ohms)
 Zg1= +j

*Based on system MVA Metered at:

Memo:



Updated 1/17/2018

**Interconnection Requirement Study - Data Request
FOR WIND GENERATION**

PROJECT: _____

DATE: _____

(Nonexclusive Preliminary List)

ALL ITEMS ARE REQUIRED AND ALL RESPONSES MUST BE FILLED UNLESS NOT APPLICABLE.

	Response
1) Please provide a plan map of the Non-Utility Generation (NUG) facility. Please indicate the interconnection point to the HECO system.	
2) Please provide the following generation and load information for the NUG facility:	
a. Gross and net output of the facility	
b. Expected KW and KVAR loads including, but not limited to, generators' auxiliary load curve, process load(s) profile(s), etc.	
c. Expected minimum and maximum MW and MVAR "import from" AND "export to" HECO.	
3) Please provide Single-Line Diagram(s), Three-Line Diagram(s), and Protective Relay List & Trip Schedule for the generation and interconnection facilities:	
a. The Single-line diagram(s) and Three-line diagram (s) should include:	
i. For main and generator step up transformer(s), please show:	
• Transformer voltage and MVA ratings.	
• Transformer impedance(s).	
• Transformer winding connections and grounding. If neutrals are grounded through impedance, please show the impedance value.	
ii. The protective relaying and metering for the generators, transformers, buses, and all other main substation equipment.	
iii. For the potential transformers, please indicate the type, quantity, ratio, and accuracy rating.	
iv. For the current transformers, please indicate the type, quantity, ratio, and accuracy rating, and thermal rating factor.	
v. Auxiliary power devices (e.g. capacitors, reactors, storage systems, etc.) and their rating(s); additional inquiries may be made to obtain technical data for these devices.	
vi. For the interconnection / tie lines (overhead or underground) and the plant's generation system, please provide the following, as applicable:	
• Installation details such as cross-section(s), plan and profiles, etc.	
• Conductor data such as size, insulation, length etc.	
• Continuous and emergency current ratings.	
• Voltage rating (nominal and maximum KV).	
• BIL rating.	
• Positive, negative, and zero-sequence impedances (resistance, reactance, and susceptance)	
• Capacitance or charging current.	
• Short-circuit current capability.	
vii. Include station power for facility and all applicable details.	
viii. All applicable notes pertaining to the design and operation of the facility.	
b. The Protective relay list & trip schedule should list the protected equipment; the relay description, type, style number, quantity, ANSI Device No., and range; and the breaker(s)/switching device(s) tripped, for both the generator protection and the interconnection facilities protection.	
c. Please provide both a paper and an electronic version (e.g. dgn, dxf, or pdf) of the single-line diagram(s) and the protective relay list & trip schedule.	
d. Single-line diagrams should be provided for both the generation plant and the interconnection substation.	

Updated 1/17/2018

**Interconnection Requirement Study - Data Request
FOR WIND GENERATION**

PROJECT: _____

DATE: _____

(Nonexclusive Preliminary List)

ALL ITEMS ARE REQUIRED AND ALL RESPONSES MUST BE FILLED UNLESS NOT APPLICABLE.

	Response
4) For the Wind Generating Facility, please provide the following data:	
a. Turbine manufacturer, Type, Size, Impedances. Attach copy of turbine data sheet.	
b. Power Factor Range Capability	
c. Turbine Reactive Power Capability Curve	
d. Auxillary loads (P, Q, Power Factor)	
e. Ramp rates (up, down) Typical and Measured Proxy Data	
f. Grounding Method (i.e. effectively grounded, resonant grounded, low inductance grounded, high-resistance grounded, low-resistance grounded, ungrounded). If the transformer is not solidly grounded or ungrounded, provide the impedance value for the grounding neutral, if applicable.	
g. Provide grounding diagram.	
h. Switching and service restoration practice	
i. Protection data (voltage ride-through and trip settings, frequency ride-through and trip settings etc.). Include setpoint and clearing time ranges for voltage and frequency settings.	
j. Details of filters etc. at Point of Interconnection	
k. Description of harmonic spectrum of inverter injection (order, magnitude)	
5) Energy Storage System, if applicable	
a. Operation characteristics	
b. Voltage level	
c. Capacity (how long and how much can the battery support)	
d. Deployment strategy/schedule	
e. Energy storage system data sheet	
6) For the Wind plant's collector system, please provide the following, as applicable:	
a. Conductor data such as size, insulation, etc.	
b. Continuous and emergency current ratings.	
c. Voltage rating (nominal and maximum kV).	
d. BIL rating.	
e. Positive, negative, and zero-sequence impedances (resistance, reactance, and susceptance).	
f. Capacitance or charging current.	
g. Short-circuit current capability.	

Updated 1/17/2018

**Interconnection Requirement Study - Data Request
FOR WIND GENERATION**

PROJECT: _____

DATE: _____

(Nonexclusive Preliminary List)

ALL ITEMS ARE REQUIRED AND ALL RESPONSES MUST BE FILLED UNLESS NOT APPLICABLE.

		Response
7)	<p>Please provide the following software models that accurately represent the Facility:</p> <p>a. Validated PSS/E load flow model up to the point of interconnection. The PSS/E model shall include the main transformer, collection system, generator step-up transformers, wind turbines, and any other components including capacitor banks, energy storage systems, DVAR, etc. An equivalent representation of the collection system, generator step-up transformers, and turbines is acceptable. Documentation on the model shall be provided.</p> <p>b. Validated PSS/E dynamic model for the wind turbine; and other components including energy storage system, DVAR, etc. if applicable. The wind turbine model shall include the generator/converter, electrical controls, plant-level controller, protection relays, and mechanical systems that impact its electrical performance. Generic and Detailed models shall be provided. Documentation on the model(s) shall be provided, including the PSS/E dyre file with model parameters.</p> <p>i. Generic models shall parameterize models available within the PSS/E standard model library.</p> <p>ii. Detailed models shall be supplied by the vendor/manufacturer as user-written models. The uncompiled source code for the user-written model shall be provided to ensure compatibility with future versions of PSS/E. In lieu of the uncompiled source code, a compiled object file and applicable library files shall be provided in PSS/E versions 33 AND 34 format. Updates of the object file compatible with future PSS/E versions must be provided as requested for the life of the project as written in the power purchase agreement. Documentation shall include the characteristics of the model, including block diagrams, values, names for all model parameters, and a list of all state variables.</p> <p>c. Validated PSCAD model of the wind turbine; and other components including energy storage system, DVAR, etc, if applicable. Documentation on the model(s) shall be provided. Refer to PSCAD Technical Memo for model requirements.</p> <p>d. Overlaid plots validating the performance of the three dynamic models for a three-phase fault. Plots shall include voltage, real and reactive power, real and reactive current.</p> <p>e. Validated Aspen Oneliner short circuit model that accurately represents the facility (including energy storage system if applicable), and is valid for all faults conditions anywhere on the Utility system. Documentation on the model(s) shall be provided. (OTHERWISE SEE ADDITIONAL TABS FOR REQUIRED INFORMATION TO MODEL INVERTER)</p>	
8)	<p>For the main transformer and generator step-up transformers, please provide:</p> <p>a. Transformer voltage and MVA ratings, and available taps. Attach copy of transformer test report or data sheet</p> <p>b. The tap settings used.</p> <p>c. The LTC Control Scheme.</p> <p>d. Transformer winding connections and grounding used. If the transformer is not solidly grounded, provide the impedance value for the grounding method.</p> <p>e. Positive, negative, and zero sequence impedance values.</p>	
9)	<p>For the circuit breakers and fault-clearing switching devices, including the generator breakers, please provide:</p> <p>a. The voltage, continuous current and interrupting capability ratings.</p> <p>b. The trip speed (time to open).</p>	

**Interconnection Requirement Study - Data Request
FOR WIND GENERATION**

Updated 1/17/2018

PROJECT: _____

DATE: _____

(Nonexclusive Preliminary List)

ALL ITEMS ARE REQUIRED AND ALL RESPONSES MUST BE FILLED UNLESS NOT APPLICABLE.

	Response
10) For the power fuses, please provide:	
a. The manufacturer, type, size, and interrupting capability.	
b. The minimum melt and total clearing curves.	
11) For the protective relaying, please provide:	
a. Data for the CTs used with the relaying including the manufacturer, type of CT, accuracy class, and thermal rating factor.	
b. Data for the PTs used with the relaying including the manufacturer, type of PT, voltage ratings, and quantity.	
12) Please provide protective relay settings for existing and proposed generators, including but not limited to, reverse power, negative sequence, over and underfrequency, over and under voltage, volts per hertz, etc.	

Instructions:

Please fill in the data in the green blanks below

(Note: This does not include the internal isolation transformer, if used)

[1] Maximum rated output power = kVA

[2] Impedances in **Per Unit** based on kVA from [1]

	R	X
Subtransient =	<input type="text"/>	<input type="text"/>
Transient =	<input type="text"/>	<input type="text"/>
Synchronous =	<input type="text"/>	<input type="text"/>
Negative Sequence =	<input type="text"/>	<input type="text"/>
Zero Sequence =	<input type="text"/>	<input type="text"/>

[3] Neutral impedance (if any) in actual **Ohms**:

R	X
<input type="text"/>	<input type="text"/>

NOTE: These parameters should reflect the inverter response for all types of faults at any point on the electrical system to which the inverter is connected. This includes faults at the inverter output terminals, and also on the 138 kV transmission system. If the stated parameters do not cover this range, please state the adjustments needed to these parameters to accurately represent the inverter response across this range.

These parameters will be used to model the inverter in the Aspen Oneliner program as shown in the sample dialog box below:

Generating Unit Info

ID= Unit rating= MVA

Impedances (pu based on unit MVA)

Subtransient	<input type="text" value="0.1"/>	+j	<input type="text" value="0.1"/>	<input type="button" value="Fill"/>
Transient	<input type="text" value="0.1"/>	+j	<input type="text" value="0.1"/>	
Synchronous	<input type="text" value="0.1"/>	+j	<input type="text" value="0.1"/>	
- sequence	<input type="text" value="0.15"/>	+j	<input type="text" value="0.15"/>	
o sequence	<input type="text" value="9999.0"/>	+j	<input type="text" value="9999.0"/>	

Neutral Impedance (in actual Ohms)

<input type="text" value="0.0"/>	+j	<input type="text" value="0.0"/>
----------------------------------	----	----------------------------------

Scheduled generation. Enter MVAR for PQ buses only

MW= <input type="text" value="0.0"/>	MVAR= <input type="text" value="0.0"/>
--------------------------------------	--

P and Q limits (MW and MVAR)

Pmax= <input type="text" value="9999.0"/>	Qmax= <input type="text" value="9999.0"/>
Pmin= <input type="text" value="-9999.0"/>	Qmin= <input type="text" value="-9999.0"/>

Instructions:

Please fill in the data in the green blanks below

- [1] Internal open circuit voltage
 Magnitude = Per Unit
 Angle = Degrees
- [2] AC Output Current Limit = Amps

NOTE: These parameters should reflect the inverter response for all types of faults at any point on the electrical system to which the inverter is connected. This includes faults at the inverter output terminals, and also on the 138 kV transmission system. If the stated parameters do not cover this range, please state the adjustments needed to these parameters to accurately represent the inverter response across this range.

These parameters will be used to model the inverter in the Aspen Oneliner program as shown in the sample dialog box below:

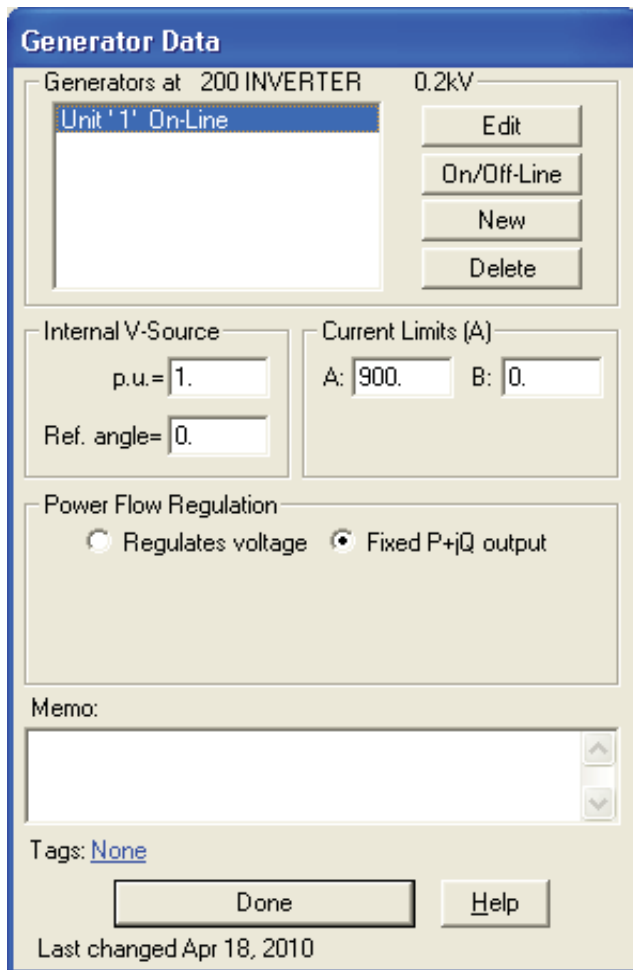

Instructions:

Please fill in the data in the green blanks below

(Note: This is not required if an internal isolation transformer is not used)

[1] Transformer rated power = kVA

[2] Winding Configuration
 Inverter Side = Delta/Wye
 Customer Side = Delta/Wye

[2] Impedances in **Per Unit** based on kVA
 Positive Sequence = R X
 Zero Sequence =

[3] Neutral impedance (if any) in actual **Ohms**:
 R X

These parameters will be used to model the inverter in the Aspen Oneliner program as shown in the sample dialog box below:

2-Winding Transformer Data

100 480 V TERM 0.48kV - 200 INVERTER 0.2kV

Name= INV ISOL TX Ckt ID= 1 MVA1= 0.25 MVA2= 0.25 MVA3= 0.25

MVA base for per-unit quantities= 0.25 Change

Y-D, delta lags (Yd 1)

R= 0.01 X= 0.03

B= 0.

Ro= 0.01 Xo= 0.03

Bo= 0.

480 V TERM 0.48 kV

Tap kV= 0.48

G1*= 0.

B1*= 0.

G10*= 0.

B10*= 0.

INVERTER 0.2 kV

Tap kV= 0.2

G2*= 0.

B2*= 0.

G20*= 0.

B20*= 0.

Neutral grounding Z (ohms)

Zg1= 14. +j 0.

*Based on system MVA

Metered at: 480 V TERM 0.48 kV

Memo:

Tags: [None](#)

Last changed Apr 18, 2010

Updated 2/13/2018

**Interconnection Requirement Study - Data Request
FOR SYNCHRONOUS GENERATION**

PROJECT: _____

DATE: _____

(Nonexclusive Preliminary List)

ALL ITEMS ARE REQUIRED AND ALL RESPONSES MUST BE FILLED UNLESS NOT APPLICABLE.

	Response
1) Please provide a plan map of the Non-Utility Generation (NUG) facility. Please indicate the interconnection point to the HECO system.	
2) Please provide the following generation and load information for the NUG facility:	
a. Gross and net output of the facility	
b. Expected KW and KVAR loads including, but not limited to, generators' auxiliary load curve, process load(s) profile(s), etc.	
c. Expected minimum and maximum MW and MVAR "import from" AND "export to" HECO.	
3) Please provide Single-Line Diagram(s), Three-Line Diagram(s), and Protective Relay List & Trip Schedule for the generation and interconnection facilities:	
a. The Single-line diagram(s) and Three-line diagram (s) should include:	
i. For main and generator step up transformer(s), please show:	
• Transformer voltage and MVA ratings.	
• Transformer impedance(s).	
• Transformer winding connections and grounding. If neutrals are grounded through impedance, please show the impedance value.	
ii. The protective relaying and metering for the generators, transformers, buses, and all other main substation equipment.	
iii. For the potential transformers, please indicate the type, quantity, ratio, and accuracy rating.	
iv. For the current transformers, please indicate the type, quantity, ratio, and accuracy rating, and thermal rating factor.	
v. Auxiliary power devices (e.g. capacitors, reactors, storage systems, etc.) and their rating(s); additional inquiries may be made to obtain technical data for these devices.	
vi. For the interconnection / tie lines (overhead or underground) and the plant's generation system, please provide the following, as applicable:	
• Installation details such as cross-section(s), plan and profiles, etc.	
• Conductor data such as size, insulation, length etc.	
• Continuous and emergency current ratings.	
• Voltage rating (nominal and maximum KV).	
• BIL rating.	
• Positive, negative, and zero-sequence impedances (resistance, reactance, and susceptance)	
• Capacitance or charging current.	
• Short-circuit current capability.	
vii. Include station power for facility and all applicable details.	
viii. All applicable notes pertaining to the design and operation of the facility.	
b. The Protective relay list & trip schedule should list the protected equipment; the relay description, type, style number, quantity, ANSI Device No., and range; and the breaker(s)/switching device(s) tripped, for both the generator protection and the interconnection facilities protection.	
c. Please provide both a paper and an electronic version (e.g. dgn, dxf, or pdf) of the single-line diagram(s) and the protective relay list & trip schedule.	
d. Single-line diagrams should be provided for both the generation plant and the interconnection substation.	

Updated 2/13/2018

**Interconnection Requirement Study - Data Request
FOR SYNCHRONOUS GENERATION**

PROJECT: _____

DATE: _____

(Nonexclusive Preliminary List)

ALL ITEMS ARE REQUIRED AND ALL RESPONSES MUST BE FILLED UNLESS NOT APPLICABLE.

	Response
4) For the Synchronous Generating Facility, please provide the following data:	
a. Generator manufacturer, Model, Type. Attach copy of generator data sheet.	
b. Generator Characteristics (SEE "GENERATOR DATA" TAB)	
c. Auxiliary loads (P, Q, Power Factor)	
d. Ramp rates (up, down) Typical and Measured Proxy Data	
e. Switching and service restoration practice	
f. Protection data (voltage ride-through and trip settings, frequency ride-through and trip settings etc.). Include setpoint and clearing time ranges for voltage and frequency settings.	
g. Details of filters etc. at Point of Interconnection	
h. Description of harmonic spectrum of generator injection (order, magnitude)	
5) Energy Storage System, if applicable	
a. Operation characteristics	
b. Voltage level	
c. Capacity (how long and how much can the battery support)	
d. Deployment strategy/schedule	
e. Energy storage system data sheet	
6) Please provide the following software models that accurately represent the Facility:	
a. Validated PSS/E load flow model up to the point of interconnection. The PSS/E model shall include the main transformer, collection system (if applicable), generator step-up transformers (if applicable), generator, and any other components including capacitor banks, energy storage systems, DVAR, etc. Documentation on the model shall be provided.	
b. Validated PSS/E dynamic model for the generator; and other components including energy storage system, DVAR, etc. if applicable. The generator model shall include the generator/converter, excitation system, governor system, power system stabilizer (if applicable), and protection relays that impact its electrical performance. Generic models shall be provided. Detailed Models shall be provided for inverter-based systems (energy storage, DVAR, etc). Documentation on the model(s) shall be provided, including the PSS/E dyre file with model parameters.	
i. Generic models shall parameterize models available within the PSS/E standard model library. Exciter model shall conform to IEEE Std 421.5. Generic models shall be selected from NERC "Acceptable_Models_list_2017-08-19.xlsx"	
ii. Detailed models shall be supplied by the vendor/manufacturer as user-written models. The uncompiled source code for the user-written model shall be provided to ensure compatibility with future versions of PSS/E. In lieu of the uncompiled source code, a compiled object file and applicable library files shall be provided in PSS/E versions 33 AND 34 format. Updates of the object file compatible with future PSS/E versions must be provided as requested for the life of the project as written in the power purchase agreement. Documentation shall include the characteristics of the model, including block diagrams, values, names for all model parameters, and a list of all state variables.	
c. Validated PSCAD model of the generator; and other components including energy storage system, DVAR, etc, if applicable. Documentation on the model(s) shall be provided. Refer to PSCAD Technical Memo for model requirements.	
d. Overlaid plots validating the performance of the three dynamic models for a three-phase fault. Plots shall include voltage, real and reactive power, real and reactive current.	
e. Validated Aspen Oneliner short circuit model that accurately represents the facility (including energy storage system if applicable), and is valid for all faults conditions anywhere on the Utility system. Documentation on the model(s) shall be provided. (OTHERWISE SEE ADDITIONAL TABS FOR REQUIRED INFORMATION TO MODEL INVERTER)	

Updated 2/13/2018

**Interconnection Requirement Study - Data Request
FOR SYNCHRONOUS GENERATION**

PROJECT: _____

DATE: _____

(Nonexclusive Preliminary List)

ALL ITEMS ARE REQUIRED AND ALL RESPONSES MUST BE FILLED UNLESS NOT APPLICABLE.

	Response
7) For the main transformer and generator step-up transformers, please provide:	
a. Transformer voltage and MVA ratings, and available taps. Attach copy of transformer test report or data sheet	
b. The tap settings used.	
c. The LTC Control Scheme.	
d. Transformer winding connections and grounding used. If the transformer is not solidly grounded, provide the impedance value for the grounding method.	
e. Positive, negative, and zero sequence impedance values.	
8) For the circuit breakers and fault-clearing switching devices, including the generator breakers, please provide:	
a. The voltage, continuous current and interrupting capability ratings.	
b. The trip speed (time to open).	
9) For the power fuses, please provide:	
a. The manufacturer, type, size, and interrupting capability.	
b. The minimum melt and total clearing curves.	
10) For the protective relaying, please provide:	
a. Data for the CTs used with the relaying including the manufacturer, type of CT, accuracy class, and thermal rating factor.	
b. Data for the PTs used with the relaying including the manufacturer, type of PT, voltage ratings, and quantity.	
11) Please provide protective relay settings for existing and proposed generators, including but not limited to, reverse power, negative sequence, over and underfrequency, over and under voltage, volts per hertz, etc.	

**Interconnection Requirement Study - Data Request
FOR SYNCHRONOUS GENERATION**

Updated 2/13/2018

PROJECT: _____
DATE: _____

*****ALL ITEMS ARE REQUIRED AND ALL RESPONSES MUST BE FILLED UNLESS NOT APPLICABLE.*****

A) Please provide the following generator machine information:	Response
a. Generator Base MVA	
b. Generator Rated Terminal Voltage (kV)	
c. Power Factor Range Capability	
d. Generator Reactive Power Capability Curve	
e. Generator impedance in per unit	
i. Positive sequence	
ii. Negative sequence	
iii. Zero sequence:	
f. Combined Turbine-Generator Inertia Constant, H (kW-sec / KVA)	
g. Speed damping factor (D)	
h. Generator Open-Circuit Saturation Factors. Attach Generator Saturation Curves.	
i. S(1.0):	
ii. S(1.2):	
i. Generator V-curve	

B) Please provide the following generator reactance data (in per unit on Machine MVA Base):	Response		Response
Direct Axis		Quadrature Axis	
a. Synchronous - Saturated (X _{dv})		a. Synchronous - Saturated (X _{qv})	
b. Synchronous - Unsaturated (X _{di})		b. Synchronous - Unsaturated (X _{qi})	
c. Transient - Saturated (X' _{dv})		c. Transient - Saturated (X' _{qv})	
d. Transient - Unsaturated (X' _{di})		d. Transient - Unsaturated (X' _{qi})	
e. Subtransient - Saturated (X ["] _{dv})		e. Subtransient - Saturated (X ["] _{qv})	
f. Subtransient - Unsaturated (X ["] _{di})		f. Subtransient - Unsaturated (X ["] _{qi})	
g. Negative Sequence - Saturated (X _{2v})			
h. Negative Sequence - Unsaturated (X _{2i})			
i. Zero Sequence - Saturated (X _{0v})			
j. Zero Sequence - Unsaturated (X _{0i})			
k. Leakage Reactance (X _{lm})			

C) Please provide the following generator time constants (in seconds):	Response		Response
Direct Axis		Quadrature Axis	
a. Transient Open Circuit (T _{do})		a. Transient Open Circuit (T' _{qo})	
b. Subtransient Open Circuit (T ["] _{do})		b. Subtransient Open Circuit (T ["] _{qo})	
c. Transient Short Circuit (T _d)		c. Transient Short Circuit (T _q)	
d. Subtransient Short Circuit (T ["] _d)		d. Subtransient Short Circuit (T ["] _q)	

Instructions:

Please fill in the data in the green blanks below

(Note: This does not include the internal isolation transformer, if used)

[1] Maximum rated output power = kVA

[2] Impedances in **Per Unit** based on kVA from [1]

	R	X
Subtransient =	<input type="text"/>	<input type="text"/>
Transient =	<input type="text"/>	<input type="text"/>
Synchronous =	<input type="text"/>	<input type="text"/>
Negative Sequence =	<input type="text"/>	<input type="text"/>
Zero Sequence =	<input type="text"/>	<input type="text"/>

[3] Neutral impedance (if any) in actual **Ohms**:

R	X
<input type="text"/>	<input type="text"/>

NOTE: These parameters should reflect the inverter response for all types of faults at any point on the electrical system to which the inverter is connected. This includes faults at the inverter output terminals, and also on the 138 kV transmission system. If the stated parameters do not cover this range, please state the adjustments needed to these parameters to accurately represent the inverter response across this range.

These parameters will be used to model the inverter in the Aspen Oneliner program as shown in the sample dialog box below:

Generating Unit Info

ID= Unit rating= MVA

Impedances (pu based on unit MVA)

Subtransient	<input type="text" value="0.1"/>	+j	<input type="text" value="0.1"/>	<input type="button" value="Fill"/>
Transient	<input type="text" value="0.1"/>	+j	<input type="text" value="0.1"/>	
Synchronous	<input type="text" value="0.1"/>	+j	<input type="text" value="0.1"/>	
- sequence	<input type="text" value="0.15"/>	+j	<input type="text" value="0.15"/>	
o sequence	<input type="text" value="9999.0"/>	+j	<input type="text" value="9999.0"/>	

Neutral Impedance (in actual Ohms)

+j

Scheduled generation. Enter MVAR for PQ buses only

MW= MVAR=

P and Q limits (MW and MVAR)

Pmax= Qmax=

Pmin= Qmin=

Instructions:

Please fill in the data in the green blanks below

- [1] Internal open circuit voltage
 Magnitude = Per Unit
 Angle = Degrees
- [2] AC Output Current Limit = Amps

NOTE: These parameters should reflect the inverter response for all types of faults at any point on the electrical system to which the inverter is connected. This includes faults at the inverter output terminals, and also on the 138 kV transmission system. If the stated parameters do not cover this range, please state the adjustments needed to these parameters to accurately represent the inverter response across this range.

These parameters will be used to model the inverter in the Aspen Oneliner program as shown in the sample dialog box below:

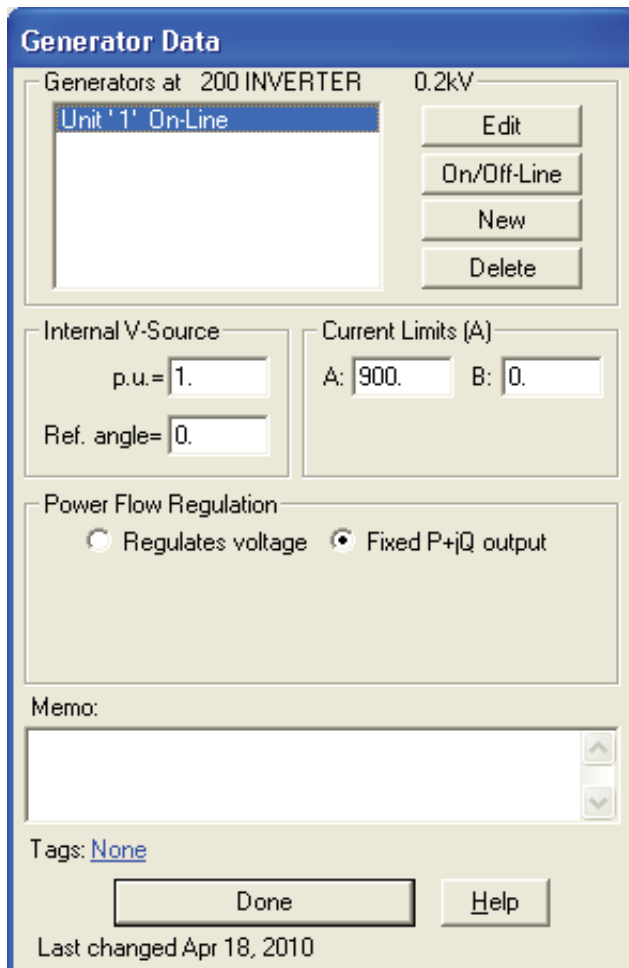

Instructions:

Please fill in the data in the green blanks below

(Note: This is not required if an internal isolation transformer is not used)

[1] Transformer rated power = kVA

[2] Winding Configuration
 Inverter Side = Delta/Wye
 Customer Side = Delta/Wye

[2] Impedances in **Per Unit** based on kVA
 Positive Sequence = R X
 Zero Sequence =

[3] Neutral impedance (if any) in actual **Ohms**:
 R X

These parameters will be used to model the inverter in the Aspen Oneliner program as shown in the sample dialog box below:

2-Winding Transformer Data

100 480 V TERM 0.48kV - 200 INVERTER 0.2kV

Name= Ckt ID= MVA1= MVA2= MVA3=

MVA base for per-unit quantities=

Y-D, delta lags (Yd 1)

R= X=

B=

Ro= Xo=

Bo=

480 V TERM 0.48 kV

Tap kV=

G1*=

B1*=

G10*=

B10*=

INVERTER 0.2 kV

Tap kV=

G2*=

B2*=

G20*=

B20*=

Neutral grounding Z (ohms)

Zg1= +j

*Based on system MVA

Metered at: 480 V TERM 0.48 kV

Memo:

Tags: [None](#)

Last changed Apr 18, 2010

Recommended PSCAD model requirements Rev. 5

Date: February 15, 2018
Prepared By: Andrew L. Isaacs P.Eng.
Garth Irwin P.Eng.

Phone: 1-204-953-1833
12-75 Scurfield Blvd.
Winnipeg, MB, Canada, R3Y 1P6
www.electranix.com

Introduction

Specific model requirements for a PSCAD study depend on the type of study being done. A study with a scope covering weak system interconnections, ride-through evaluation, short term¹ event response, and fast control interaction with nearby devices (for example) would require a model which has the following characteristics. Some specialty studies may require other features.

Model Accuracy Features

For the model to be sufficiently accurate, it must:

- A. *Represent the full detailed inner control loops of the power electronics.* The model cannot use the same approximations classically used in transient stability modeling, and should fully represent all fast inner controls, as implemented in the real equipment. It is possible to create models which embed the actual hardware code into a PSCAD component, and this is the recommended type of model.²
- B. *Represent all control features pertinent to the type of study being done.* This may include external voltage controllers, plant level controllers, customized PLLs, ride-through controllers, SSCI damping controllers or others. As in point A, actual hardware code is recommended to be used for most control and protection features. Operating modes that require system specific adjustment should be user accessible. In most cases, plant level voltage control should be represented along with adjustable droop characteristics.
- C. *Represent all pertinent electrical and mechanical configurations.* This includes any filters and specialized transformers. There may be other mechanical features such as gearboxes, pitch controllers, or others which should be modelled if they impact electrical performance within the timeframe of the study. Any control or dynamic features of the actual equipment which may influence behaviour in the simulation period which are not represented or which are approximated should be clearly identified.
- D. *Have all pertinent protections modeled in detail for both balanced and unbalanced fault conditions.* Typically this includes various OV and UV protections (individual phase and RMS), frequency protections, DC bus voltage protections, converter overcurrent protections, and often other inverter

¹ Example analysis periods could be 2 to 10 seconds from fault inception. Some studies could require longer periods.

² The model must be a full IGBT representation (preferred), or may use a voltage source interface that mimics IGBT switching (ie. A firing pulse based model). A three phase sinusoidal source representation is not acceptable. Models manually translated block-by-block from MATLAB or control block diagrams may be unacceptable because the method used to model the electrical network and interface to the controls may not be accurate, or portions of the controls such as PLL circuits or protection circuits may be approximated or omitted. Note, however, that Matlab may be used to generate C code which is used in the real control hardware, and if this approach is used by the developer, the same C code may be directly used to create an extremely accurate PSCAD model of the controls. The controller source code may be compiled into DLLs or binaries if the source code is unavailable due to confidentiality restrictions.

If the model is assembled using standard blocks available in the PSCAD master library, approximations are usually introduced, and specific implementation details for important control blocks may be lost. In addition, there is a risk that errors will be introduced in the process of manually assembling the model. For this type of manually assembled model, (not using a direct “real code” embedding process), extra care is required, and validation is recommended.

specific protections. As in point A, actual hardware code is recommended to be used for these protection features.

- E. *Be configured to match expected site-specific equipment settings.* Any user-tunable parameters or options should be set in the model to match the equipment at the specific site being evaluated, as far as they are known. Default parameters may not be appropriate.

Model Usability Features

In order to allow study engineers to perform system analysis using the model, the PSCAD model must:

- F. *Have control or hardware options which are pertinent to the study accessible to the user.* Examples of this could include protection thresholds, real power recovery ramp rates, or SSCI damping controllers.³ Diagnostic flags (eg. flags to show control mode changes or which protection has been activated) should be visible to aid in analysis.
- G. *Be accurate when running at a simulation time step of 10 us or higher.* Often, requiring a smaller time step means that the control implementation has not used the interpolation features of PSCAD, or is using inappropriate interfacing between the model and the larger network. Lack of interpolation support introduces inaccuracies into the model at larger simulation time-steps.
- H. *Have the ability to disable protection models.* Many studies result in inadvertent tripping of converter equipment, and the ability to disable protection functions temporarily provides study engineers with valuable system diagnostic information.
- I. *Include documentation and a sample implementation test case.* Test case models should be configured according to the site-specific real equipment configuration. Access to technical support engineers is desirable.
- J. *Accept external reference variables.* This includes real and reactive power ordered values for Q control modes, or voltage reference values for voltage control modes. Model should accept these reference variables for initialization, and be capable of changing these reference variables mid-simulation, ie. dynamic signal references.
- K. *Be capable of initializing itself.* Once provided with initial condition variables, the model must initialize and ramp to the ordered output without external input from simulation engineers. Any slower control functions which are included (such as switched shunt controllers) should also accept initial condition variables if required.
- L. *Have the ability to scale plant capacity.* The active power capacity of the model should be scalable in some way, either internally or through an external scaling transformer⁴. This is distinct from a dispatchable power order, and is used for modeling different capacities of plant or breaking a lumped equivalent plant into smaller composite models.

³ Care should be taken to ensure that any user-settable options are not changed in a way that is not implementable in the real hardware, and that any selectable options are actually available at the specific site being considered. Discussion is recommended with the manufacturer prior to any changes being made in model configuration.

⁴ A free publicly available scaling transformer suitable for this purpose is available in the E-Tran library.

Study Efficiency Features

In addition, the following elements are required to improve study efficiency, model compatibility, and enable other studies which include the model to be run as efficiently as possible. If these features are not supported, additional discussion is required⁵:

- M. Model should be compiled using Intel Fortran compiler version 9 or higher. Intel Fortran version 12 or higher is preferred. Model should not be dependent on a specific Fortran version to run.
- N. Model uses PSCAD version 4.5.3 or higher.
- O. Model initializes as quickly as possible (for example <5 seconds) to user supplied terminal conditions.
- P. Model supports multiple instances of its own definition in the same simulation case.
- Q. Model supports the PSCAD “snapshot” feature.
- R. Model supports the PSCAD “multiple run” feature.

⁵ Electranix has parallelization tools available (E-Tran Plus for PSCAD) which can circumvent compatibility concerns in some cases.

REQUEST FOR PROPOSALS
FOR
VARIABLE RENEWABLE DISPATCHABLE GENERATION
AND
ENERGY STORAGE
ISLAND OF HAWAI‘I

AUGUST 22, 2019

Docket No. 2017-0352

*Appendix C – Code of Conduct Procedures
Manual*

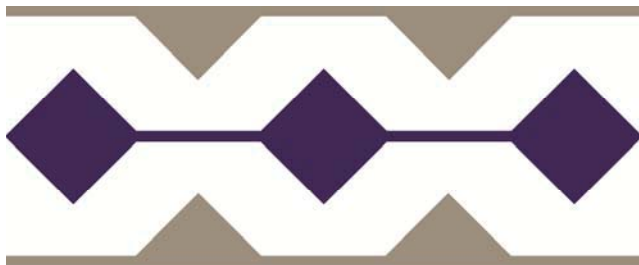

**Hawai‘i
Electric
Light**

**HAWAIIAN ELECTRIC COMPANY, INC.
MAUI ELECTRIC COMPANY, LIMITED
HAWAII ELECTRIC LIGHT COMPANY, INC.**

Code of Conduct Procedures Manual

I. INTRODUCTION

The Framework for Competitive Bidding ("Framework") adopted on December 8, 2006, by the Public Utilities Commission of the State of Hawaii (the "Commission") pursuant to Decision and Order No. 23121 (Docket No. 03-0372, Instituting a Proceeding to Investigate Competitive Bidding for New Generating Capacity in Hawaii) requires that the utility develop and follow a Code of Conduct whenever a utility or its affiliate seeks to advance an energy generation resource proposal in response to a request for proposals ("RFP") issued by the Company. Section III.A.4 of the Framework required the utility to submit to the Commission for review and approval (subject to modification if necessary) a Code of Conduct prior to the commencement of any competitive bid process under the Framework. On June 7, 2007, by letter to the Commission, the Company submitted its form of Code of Conduct for Commission review and approval. By Decision and Order No. 23614 (Docket No. 03-0372), issued August 28, 2007, the Commission approved the Code of Conduct. Amendments to the Code of Conduct were approved by the Commission for Stage 1 of the Companies' 2018 Variable RFP by Order No. 35286, issued on February 20, 2018, in Docket No. 2017-0352.

This Code of Conduct Procedures Manual has been developed to outline the procedures to be followed and the policies that have been developed surrounding the implementation of the Companies' competitive bidding process for new generating capacity. The Companies' initial Code of Conduct Procedures Manual ("Manual") was approved by the Commission for Stage 1 of the Companies' 2018 Variable RFP by Order No. 35286, issued February 20, 2018, in Docket No. 2017-0352. This Code of Conduct Procedures Manual has been developed for the Companies' Variable Renewable Dispatchable Generation and Energy Storage Stage 2 RFP and in accordance with the requirements of Section IV.H.9.a(iii) of the Framework and outlines requirements (1), (3) and (4) of such section, namely: (1) the protocols for communicating with Proposers, the Company Self-Build team, and others; (3) the documentation forms, including logs for any communications with proposers; and (4) other information

consistent with the requirements of the solicitation process. Requirement (2) of the section, the evaluation process in detail and the methodologies for undertaking the evaluation process for the RFP are described in detail in Chapter 4 (Evaluation Process and Evaluation Criteria) of the Variable Renewable Dispatchable Generation and Energy Storage RFP Stage 2. The bid evaluation process and methodology will consider both price/system impacts and non-price criteria in accordance with Section IV.E of the Framework and Tariff Rule 19 (See Appendix I (Tariff Rule 19) of the RFP).

The procedures and policies set forth herein have been designed to ensure that the procurement process is undertaken in a fair and equitable manner and that each Proposer is afforded an equal opportunity to participate and compete within the RFP requirements.

This Code of Conduct Procedures Manual is intended to be followed by Company personnel in connection with implementing the Companies' solicitation process and to manage communications between Company personnel and consultants participating in the RFP processes covered by the Framework. Necessary additions, deletions, and/or changes depending on the circumstances surrounding the RFP and directions from the IO may be required.

II. DEFINITIONS

- Affiliate – Any person or entity that possesses an “affiliated interest” in a utility as defined by section 269-19.5, Hawaii Revised Statutes (“HRS”), including a utility’s parent holding company but excluding a utility’s subsidiary or parent which is also a regulated utility.
- Affiliate Team – Employees and consultants of an Affiliate of the Company who prepare a proposal to be submitted to the Company in response to a Company RFP.
- ATRs – The Affiliate Transaction Requirements, issued by the Commission, applicable to the Companies and Affiliates, attached as Exhibit B to Order No. 36112 issued on January 24, 2019 in Docket No. 2018-0065.

- Code of Conduct – A written code developed by Hawaiian Electric Company, Inc., Maui Electric Company, Limited and Hawaii Electric Light Company, Inc. (each, a “Company” and collectively, the “Companies”) to ensure the fairness and integrity of the competitive bidding process, in particular where the host utility or its affiliate seeks to advance its own resource proposal in response to an RFP. The Code of Conduct follows the requirements described in Section IV.H.9.c of the Framework and was approved by the Commission in Decision & Order No. 23614, and amended and approved by Order No. 35286 issued on February 20, 2018, in Docket No. 2017-0352.
- Communications Log – A written record to note activities and/or information shared between the Company RFP Team or Company Self-Build Team with Shared Resources or Unassigned Company Resources, accessed via the RFP Communication Tool Kit SharePoint Site.
- Company Executive in Charge – A Company’s executive responsible for ensuring compliance with this Code of Conduct and serving as the point of contact for the Independent Observer for reporting any violations by the Company of the Code of Conduct. For any RFP of the Companies, the Company Executive in Charge shall be the Senior Vice President of Business Development & Strategic Planning. The Company’s Corporate Compliance Officer shall remain responsible for the Companies’ independent corporate code of conduct and may support compliance matters and questions arising with employees, agents and other representatives of the Company, e.g., conflicts of interest, with respect to this Code of Conduct.
- Company RFP Team – The Company personnel and outside consultants responsible for the development of the Company’s RFPs conducted under the Framework and the evaluation of bids submitted in response to these RFPs. Subject to the transfer rules specified herein, the Company RFP Team will have fixed team members who will not have any involvement with the Company Self-Build Team for the subject RFP.
- Company Self-Build Team – The Company personnel and outside consultants responsible for the development of the Company’s self-build response to the RFP. Subject to the transfer rules specified herein, the Company Self-Build Team

- will have fixed team members who will not have any involvement with the Company RFP Team for the subject RFP.
- Competitive Bidding Code of Conduct Acknowledgement of Receipt (Acknowledgement) – A document that must be signed that shows acknowledgement of receipt of the Code of Conduct and a person’s responsibility to comply with the Code.
 - Confidential Information – Any non-public information developed and provided by the Company (i.e., proprietary system information, etc.) or Proposers during the RFP process (such non-public information may include, for example, the identity of competing Proposers, and their technical, trade or financial information). This term includes any material non-public information regarding the RFP process developed for and used during the competitive bidding solicitation process, such as the evaluation process or criteria. Confidential Information does not include public information, such as information in the Companies’ public filings with the Commission.
 - Director of Renewable Acquisition – The supervisor of the Division that will oversee the Company’s competitive bidding process.
 - Eligible Proposer – A Proposer who has met the minimum requirements and threshold requirements in the RFP necessary to remain eligible to compete in the process.
 - Energy Contract Manager – The staff position(s) within the Company’s Renewable Acquisition Division responsible for managing the Company RFP Team(s). The Energy Contract Manager shall be a member of the Company RFP Team he/she manages.
 - Framework – The Framework for Competitive Bidding contained in Decision & Order No. 23121 issued by Commission on December 8, 2006, to establish rules for competitive bidding in response to a request for proposals when a utility seeks to acquire new generation resources.
 - Independent Observer (“IO”) – The neutral person or entity appointed by the Commission to monitor the utility’s competitive bidding process, and to advise the utility and Commission on matters arising out of the competitive bidding process, as described in Part III.C of the Framework.

- Manager of Energy Procurement - The supervisor of the department within the Renewable Acquisition Division responsible for directing the resources responsible for the implementation of the competitive bidding process pursuant to the Framework. The Manager of Energy Procurement will report to the Director of Renewable Acquisition on the status of the competitive bidding process and shall be a member of the Company RFP Team.
- Non-Price Evaluation Team – Employees and consultants of the Company who evaluate the Proposal non-price related criteria as set forth in these RFPs. Non-Price Evaluation Team members will not include any Shared Resources and will be solely made up of Company RFP Team Members.
- Price Evaluation Team – Employees and consultants of the Company who evaluate the Proposal price related criteria set forth in these RFPs. Price Evaluation Team members will not include any Shared Resources and will be solely made up of Company RFP Team Members.
- Proposer – Entity who submits or plans to submit a proposal in response to a Company-issued RFP. An Affiliate of the Company or a Company Self-Build Team participating in the RFP and submitting a proposal shall be considered a Proposer.
- RFP – A written request for proposals issued by one of the Companies to publicly solicit bids to supply future generating capacity to the Company pursuant to the competitive bidding process established in the Framework.
- Roster – A consolidated list of members that comprise the Company RFP Team, Company Self-Build Team, Shared Resources and Unassigned Company Resources located in the RFP Communication Tool Kit SharePoint Site. Company employee names and titles and consultants in their designated role will be identified.
- Shared Resource – Company employees and consultants who, because of the scarcity of their expertise within the Company, are designated and authorized to provide information or input to both the Company RFP Team and the Company Self-Build Team (but not any Affiliate Team) and is not a resource dedicated to either team. For example, Shared Resources may include an environmental attorney and members of the Company’s Risk Management Department.

- Unassigned Company Resource – Company employees unassigned to an essential team that may be called upon by the Company RFP Team and/or the Company Self-Build Team (but not any Affiliate Team) to assist in meeting unforeseen tasks for the RFP or the self-build proposal. For example, the Company RFP Team may be unable to evaluate an unforeseen technical specification included in a bid. In that event, the Company RFP team would need to request assistance from a Company employee or a consultant that is not already assigned to an essential team and possesses the specific expertise. Such personnel are intended to assist the requesting team only in an ad hoc manner, limited in scope and purpose to the particular task required.

III. STATEMENT OF OBJECTIVES

From time to time, each of the Companies will be proposing to seek power supply proposals for electric generation resources that best meet the needs of the respective Company's system. The timing for issuance of RFPs for each of the systems will be dependent upon the Commission's approval of the associated resource plan and the necessary competitive bidding procedures identified in the Framework and upon the timing of the need for capacity for each island. Each of the Companies will undertake a detailed multi-stage review and evaluation process whereby eligible proposals will be selected based upon their ability to most cost-effectively and reliably satisfy the requesting Company's resource requirements. While cost minimization is a major criterion, the Companies' objective is to select those resources which, in their opinion, represent the best value to the Companies and their customers regarding economic and technical attributes, limited risk, and flexibility for meeting their projected requirements. The individual RFPs seeking generation resources, including the Variable Renewable Dispatchable Generation and Energy Storage Stage 2 RFP, are part of the Companies' overall renewable resource procurement plan, which is based on the Companies' ongoing long range planning, but also may be revised on short notice in order to address unforeseen events such as premature equipment failures or natural events. With each successive RFP, the Companies are not only seeking to procure additional renewable energy that is required to meet the RPS goals, but also continually building off results of previous RFPs to continue to meet the above objective.

The needs for each island system vary, and therefore the timing and schedule of the RFPs cannot be consistently coordinated. Multiple RFPs will likely be active at the same time. Furthermore, because the Companies must work expeditiously, successive RFPs will consider previous procurements and build on appropriate aspects of prior successful RFP execution plans. Therefore, in order to consistently ensure the competitive benefits of the procurement process while continuing to provide equitable and fair consideration for all proposals, the Companies will designate and maintain the Roster. Subject to the transfer rules specified herein, the Roster will be maintained for the durations of the RFPs. The Companies also intend that the evaluation process will be well-documented so that the results of the evaluation can be fully reviewed by an IO to confirm that all proposals were treated in a fair and consistent manner.

The Code of Conduct and this Manual address (1) communication requirements and procedures associated with the relationship between utility employees (Company RFP Team, Company Self-Build Team, Shared Resources and Unassigned Company Resources); (2) communication requirements and procedures associated with the relationship between the Company RFP Team, the Company Self-Build Team and Proposers; and (3) communication requirements associated with the relationship between Company management and the Company RFP Team.

The Code of Conduct and this Manual also include procedures for the sharing of resources, where appropriate, by the Company RFP Team and the Company Self-Build Team for the purposes of completing their efforts to effectively evaluate an RFP or to submit a bid in response to an RFP. The small size of the Companies and limitation of resources will require specialized services, information exchange and sharing of resources in certain limited circumstances. Company personnel and consultants identified as "Shared Resources" shall be designated by the Companies for this specific purpose.

IV. ORGANIZATION AND COMMUNICATION RESPONSIBILITIES

This section outlines the RFP organizational structure for the development of the RFP and the Company self-build option and the organization's responsibilities to ensure that communications between Company personnel and consultants working on their respective RFP or self-build projects are conducted in a fair, consistent, and equitable basis so that the Company Self-Build Team does not enjoy any unfair advantage over other Proposers responding to an RFP.

A. Organization

The Company shall identify and maintain two separate teams to facilitate the independence and objectivity of the Company resources working on an RFP and ensure an arms-length relationship with the resources working on the Company's self-build project to avoid any real or perceived inequity in an RFP process. The two essential teams shall be the "Company RFP Team" and the "Company Self-Build Team."

Other limited Company resources, such as select staff from various functional areas of the Company that are in short supply and thus cannot be dedicated solely to either team, may be designated as "Shared Resources" to perform services for the Company RFP Team and Company Self-Build Team. Shared Resource employees are allowed to carry on with both their RFP (for either the Company RFP Team and/or the Company Self-Build Team) and regular functions throughout the resource planning process (including the development of any Company Parallel or Contingency Plan as defined in the Framework), which may require communications with or services performed for the Company Self-Build Team. Shared Resource employees, however, will not participate in the evaluation and selection process of proposals submitted in response to an RFP. Rules for communications between Shared Resources and the essential teams are specified below.

Company employees unassigned to an RFP may be called upon by the Company RFP Team, Company Self-Build Team, or both for help to meet unforeseen tasks. After completing the Code of Conduct training, these "Unassigned Company Resources" are

eligible to assist on an ad hoc basis with the requirement that all communications as an Unassigned Company Resource must be memorialized and logged in the same manner as communications with Shared Resources on the Communication Log. If an Unassigned Company Resource is called upon repeatedly for a substantial amount of assistance by a particular team, the employee should be assigned to such team or evaluated for designation as a shared resource.

B. Essential Teams

1. Company RFP Team. The Company RFP Team, tasked with preparing the RFP and evaluating the responses and bids in response to the RFP, will consist primarily of Director/Manager-level and other experienced employees together with possible outside consultants, with backgrounds in a number of disciplines necessary to conduct a thorough evaluation of each proposal. The Company RFP Team will be comprised of a Price Evaluation Team and a Non-Price Evaluation Team and will be prepared to evaluate proposals on the basis of their price and non-price aspects pertaining to their level of expertise. Members of the Company RFP Team will include professionals with experience in the following areas of expertise: engineering, siting/land use, environmental, transmission planning, fuel procurement, legal, financial planning, system operations, integrated resource planning, generation planning, production cost analysis, and others as needed.

The Price Evaluation Team and the Non-Price Evaluation Team will conduct their sections of the bid evaluation process separately and will not share the results of their evaluation with members of the other sub-team. Each team will submit their evaluation results to an oversight team, which will be responsible for compiling the results of the evaluations and selecting the short-list.

The Energy Contract Manager will be responsible for directing the evaluation efforts of the Company RFP Team when the proposals are received. The Energy Contract Manager will be responsible for maintaining the documentation underlying the evaluation of each proposal as well as all communications with Proposers.

2. The Company Self-Build Team. The Company Self-Build Team, tasked with preparing any Company proposal to be submitted by the Company in response to a Company RFP, will consist primarily of Company employees, along with possible outside consultants with backgrounds in a number of disciplines necessary to complete a competitive proposal in response to the Company RFP. The members of the team will include professionals with experience in the following areas of expertise: engineering, siting/land use, environmental, transmission planning, fuel procurement, legal, financial planning, system operations, integrated resource planning, generation planning, production cost analysis, and others as needed.

3. Affiliate Team. Any Affiliate Team will be comprised solely of employees and consultants of the Affiliate and no Company employee or consultant shall serve as a member of an Affiliate Team; provided, however, that a consultant may perform services for an Affiliate and the Company so long as appropriate "walls" are established satisfactory to the Company that ensures that employees of the consultant working for the Affiliate Team do not also perform work for the Company nor communicate with employees of the consultant performing work for the Company, and vice versa. The Company will inform consultants providing services for the Company RFP Team of these separation requirements, and will seek confirmation in writing from any consultant performing services for an Affiliate and the Company that such separation requirements will be met. Affiliate Teams will be considered and treated as separate independent third-party Proposers for all purposes within any RFP and shall have no access to, interaction or communications with Shared Resources or Unassigned Company Resources for the purpose of completing a proposal in response to any RFP. Affiliate Teams shall also be subject at all times to the terms, conditions and restrictions specified in the Company's ATRs.

4. Transfers between Teams. As members of both the Company RFP Team and the Company Self-Build Team are intended to be fixed, transfers between teams should not be permitted. However, there will be instances where a member of a particular team (whether Company RFP or Company Self-Build) transfers to a position in which he/she may be requested, as part of his/her new job responsibilities,

to participate as a member of the other team. Such employee shall not be permitted to transfer from one team to the other during the pendency of any particular RFP (or stage or phase of a particular RFP). After completion of the RFP (or stage or phase of a particular RFP) under which the employee recently participated, the employee may transfer to the other team under the following conditions: (a) the employee is prohibited from disclosing any Confidential Information known to such employee as a result of being a member of his/her former team with members of the new team he/she is joining; and (b) for a period of one (1) year, such employee shall not participate or be involved in the evaluation of any subsequent stage(s) or phase(s) of a prior RFP which such employee participated in with his/her former team.

Transfers of employees between the Company and any Affiliate shall be subject to the terms, conditions and restrictions specified in the ATRs.

C. Communications Protocols

1. Overview and General Requirements.

The Company has developed policies and procedures governing communication between the Company RFP Team, the Company Self-Build Team, Shared Resources, the Proposers, the IO, and with the Commission regarding RFP design and bid evaluation. Bid information and evaluation data and information shall not be communicated between members of the Company RFP Team, outside parties and other employees within the Companies except to those with a business need to know.

To ensure that the competitive bidding process is fair and unbiased, that all Proposers have access to the same information so that no Proposer has an unfair advantage, and that any Company self-build and/or Affiliate proposals do not have any unfair competitive advantage over third-party bids, the Companies shall follow the Code of Conduct whenever the utility or its Affiliate is seeking to advance a resource proposal as provided in Section IV.H.9.b of the Framework.

Each employee or consultant on the Company RFP Team, Company Self-Build Team and Shared Resources shall read, acknowledge and sign the Competitive

Bidding Code of Conduct Acknowledgement of Receipt. Unassigned Company Resources who are called upon by the Company RFP Team or Company Self-Build Team for help to meet unforeseen tasks shall also read, acknowledge and sign the Competitive Bidding Code of Conduct Acknowledgement of Receipt.

The Company issuing the RFP will establish a shared drive on its corporate computer network designed to maintain the bid evaluation documentation and other information associated with the bidding process. Only Company RFP Team members will have access to all the files on the shared drive.

In cases where staffing and resources are limited or constrained, the Company may identify Shared Resources or those employees eligible to provide information or serve as a resource to both the Company RFP Team and the Company Self-Build Team. Specific rules to log communications with the Company RFP Team or the Company Self-Build Team are described below.

Shared Resources will not have access to the Company's shared drive established for the RFP process which will include the documentation of the bid evaluation results.

Team members should clearly mark all e-mails, documents, or other communications that contain Confidential Information and make clear which team should not receive it with the following header or a substantially similar message: "This communication contains self-build information that must be kept confidential. DO NOT copy, forward, or discuss the contents with Company RFP Team members" OR "This communication contains Company RFP Team information that must be kept confidential. DO NOT copy, forward, or discuss the contents with Company Self-Build Team members."

2. Communications Between the Company RFP Team and Proposers, including the Company Self-Build Team and any Affiliate Team.

During the RFP process, the Energy Contract Manager shall serve as the primary contact person for all RFP communications with Proposers. This is important from the standpoint of maintaining consistency and confidentiality of information between Proposers and the Company. For documentation and oversight purposes, all communications from Proposers must be submitted to an established website link provided by the Company (the "Company RFP website"). The IO will monitor all communications through the Company RFP website. To ensure fair and equal access to information, any Company Self-Build Team and/or Affiliate Team shall be considered a Proposer for communication purposes and any request for information from the Company Self-Build Team or Affiliate Team to the Company RFP Team shall be through the Company RFP website.

Subject to confidentiality obligations, it is the objective of the Code of Conduct that all Proposers, including the Company Self-Build Team and any Affiliate Team, receive access to information released by the Company RFP Team, whether in response to a question from a Proposer or not, at the same time.

The communications process for addressing questions and requests for information from Proposers, and for the Company RFP Team to provide information to Proposers, is provided below:

- a. Other than during Company sponsored conferences, Proposers must submit all questions to the Company RFP website or the designated RFP email address (if the Company RFP website has not been opened yet for the RFP).
- b. Questions will be reviewed and responses will be coordinated with the appropriate functional area within the Company for a response. Every reasonable effort will be made to provide responses in a timely manner.

- c. All responses, including the classification of such response, i.e., whether non-confidential or confidential as described below, will be provided to the IO for monitoring purposes via email or the PowerAdvocate messaging system. The IO may choose to comment on any response at its discretion.

- d. Depending on the questions received, responses may involve Confidential Information of the Company and/or Proposers. Release of any Company Confidential Information must be approved in advance by the Company executive authorized to release the Confidential Information. Any release of Company Confidential Information shall be accompanied by appropriate confidentiality and non-disclosure agreements, protective orders or other means required to maintain the confidentiality of the Company Confidential Information while still permitting its disclosure under circumstances deemed appropriate by the responsible Company executive. Other non-Company Confidential Information will not be shared without the prior written consent of the owner of such Confidential Information and the execution of appropriate confidentiality and non-disclosure agreements by all recipients of such Confidential Information. Responses will be categorized as follows:
 - i. Non-Confidential Responses: Questions and responses will either be posted directly on the Company RFP website (process-related questions or simple, non-substantive information) or a description of the information that can be made available will be posted and Proposers will be instructed to submit a request to the Company via the Company RFP website to receive a copy.

 - ii. Confidential Responses: Questions and a description or notice of a Confidential Information response will be posted on

the Company RFP website and Proposers will be instructed to submit a request to the Company via the Company RFP website to receive instructions on how to access the Confidential Information. The Confidential Information will only be provided to the requestor after receipt of an executed confidentiality and non-disclosure agreement. Only those who have qualified to submit a bid (i.e., Eligible Proposers) and have executed a confidentiality and non-disclosure agreement will be considered for receipt of Confidential Information.

iii. Process for Distribution of Confidential Information:
Confidential Information provided in response to questions from proposers may be made available only to parties as indicated above via the following:

A. Confidential Information that is approved for exchanging on a secured access site: (1) Confidential Information may be made available on a secured website with an individual password provided to each approved Proposer; and (2) Confidential Information in documents may be transmitted to approved recipients through the Company's secure email system.

B. Confidential Information that can be made available for inspection only, but cannot be copied: There may be some types of Confidential Information that the Company may consider making available for inspection only with no copies allowed. This type of Confidential Information will be made available on Company premises for inspection only. Proposers will be advised via the Company RFP website to make arrangements with Company staff to view the Confidential Information.

C. Confidential Information that may not be released:

In the event that Proposers submit questions that require responses that the Company feels are not appropriate to provide for reasons which may include, but not be limited to, safety, security, protection of trade secrets or intellectual property rights, Proposers will be advised as such via the Company RFP website.

- e. Prior to and during the RFP, and outside of the Company RFP website protocol, developers may direct questions to the Company prior to submitting a Proposal to discuss specific questions regarding their specific Proposal. Questions shall be directed to the Company Contact for Proposals listed in RFP Section 1.6. Questions and responses that do not contain Confidential Information and which are deemed relevant to all Proposers will be published without identifying information via the Company RFP website.
- f. Once bids are received, the Company may submit information requests to Proposers to clarify their proposals or request additional information. All contacts with Proposers will be through the Company RFP website. All contacts and information exchanged will be under the oversight of the IO.
- g. A single exception to the communication process outlined above shall be instituted for the purpose of facilitating the verification of proposed project models and documentation required to perform the IRS. For this limited scope, the Company's Manager of Interconnection Services will serve as the primary contact person for all such interconnection communications with the Proposers on the Priority List, provided that all necessary confidentiality and

non-disclosure agreements are in place. The Manager of Interconnection Services and personnel in the Interconnection Services Department shall be members of the Company RFP Team. Interconnection communications will be limited to a Proposer's bid and no more information other than as necessary to facilitate such communications will be permitted. Discussion of locations of proposed projects shall be limited to that necessary only to determine the interconnection requirements of such project. The IO shall have the right to monitor all such communications in his/her discretion.

3. Communications Between the Companies and the Commission.

The Company's Regulatory Affairs staff will be responsible for initiating communication with the Commission regarding the RFP or the Companies' evaluation process. Regular updates may be provided to the Commission regarding the RFP process if requested.

4. Communications Between the Company RFP Team and the IO.

Communications between the Company RFP Team and the IO will be required for many aspects of the evaluation process. The IO is also required to maintain confidentiality of any Confidential Information. The IO will coordinate all activities through the Energy Contract Manager. The IO will be invited to participate in any meetings or discussions between the Company RFP Team and the Proposers and other communications as noted above. Sufficient notice will be provided whenever possible and teleconference and/or web conference alternatives may be utilized.

5. Communications Between the Company RFP Team and the Company Self-Build Team or any Affiliate Team.

Any communication between the Company RFP Team and the Company Self-Build Team or any Affiliate Team with respect to the RFP shall be handled no differently than with Proposers and other outside parties. Accordingly, the Company Self-Build Team or any Affiliate Team will be required to submit any questions or information requests to the Company RFP Team via the Company RFP website and all responses will be provided in the same manner as to other Proposers. Accordingly, as stated in Section 2 above, responses will be provided to the IO for monitoring purposes via email or the PowerAdvocate messaging system. Members of the Company RFP Team are prohibited from providing any input into the development of the self-build option by the Company or an Affiliate. Company RFP Team members are prohibited from sharing any Confidential Information (i.e., detailed evaluation criteria, other proposals, etc.) with any Company Self-Build or Affiliate Teams except in accordance with the procedures in the Code of Conduct, this Manual or the RFP.

Company RFP Team members and Company Self-Build Team members may continue to work with each other on projects not related to the RFP. Further, members of each respective team do not have to be physically separated from each other, but members of each team must make reasonable efforts to keep all Confidential Information (including electronic data) secure and inaccessible to the other team.

Company RFP Team members and Affiliate Team members may continue to work with each other on matters not related to the RFP as permitted under the ATRs.

6. Communications among the Company RFP Team, the Company Self-Build Team and Shared Resources.

Shared Resources may provide services to the Company RFP Team and the Company Self-Build Team (but not any Affiliate Team). Shared Resources shall be limited as much as possible to instances where Company resources cannot provide a dedicated member to the Company RFP Team and the Company Self-Build Team at the

same time and still provide the necessary functions of its area to the Company as a whole. Shared Resources are expressly prohibited from providing any information developed on behalf of the Company RFP Team to the Company Self-Build Team or any information developed on behalf of the Company Self-Build Team with the Company RFP Team, except through the formal communication process outlined above, i.e., through the Company RFP website.

Additionally, a written record of the time, date and substance of all conversations, data and written material directly or indirectly exchanged with the Company RFP Team or the Company Self-Build Team that pertain to the RFP shall be maintained on the Communications Log. The RFP Communication Tool Kit SharePoint Site will be set up and managed by the Energy Contract Manager to provide an easy to use and understand mechanism to log and memorialize these conversations.

Shared Resources will not have direct access to the Company's shared drive developed for the RFP process which will include documentation of the bid evaluation results.

7. Communications between the Company RFP Team, the Company Self-Build Team and any Unassigned Company Resource or consultant that is not a Shared Resource.

There may be times where a Company RFP or Company Self-Build team (but not an Affiliate Team) member may need ancillary or other ministerial or administrative assistance that requires communication and/or assistance from Company personnel who are neither on any team nor considered a Shared Resource. Under those circumstances, such personnel may assist the requesting team member on an ad hoc basis upon the following conditions:

- a. The essential team member making the request must inform the Company personnel that sharing of the requested information or

assistance with the other team, be it the Company RFP or Company Self-Build Team, is expressly prohibited under the Code of Conduct.

b. The assisting Company personnel shall complete the Code of Conduct training and sign the Acknowledgement.

c. The assisting Company personnel shall be directed to the Roster provided by such requesting team member to determine and/or confirm the restrictions on communication with the other team members. The essential team member making the request will ensure the Roster is updated by the Energy Contract Manager to include the assisting Company personnel.

d. A written record of the time, date and substance of all conversations, data and written material directly or indirectly exchanged with the Company RFP Team or the Company Self-Build Team that pertain to the RFP shall be maintained on the Communication Log. The RFP Communication Tool Kit SharePoint Site will be set up and managed by the Energy Contract Manager to provide an easy to use and understand mechanism to log and memorialize these conversations.

e. If assistance from an Unassigned Company Resource becomes more than occasional or more substantive than ancillary, ministerial or administrative services, the Unassigned Company Resource should be considered for inclusion on the team that he/she has been assisting on such basis. Additionally, the Unassigned Company Resource may also be considered for inclusion as a Shared Resource. Members of the Company RFP Team and/or Company Self-Build Team shall consult with the Company executive for resolution.

8. Communications between the Company RFP Team, the Company Self-Build Team and Company Management.

The Company RFP Team and the Company Self-Build Team will necessarily require management approval of the RFP and the Company Self-Build Team proposal. Because of the size of the Company, it may be possible that a single employee (at whatever level) (the "Approver") may have approval responsibility for matters affecting the RFP and the Company Self-Build Team proposal. Approvers in this situation must use their best judgment in making decisions reviewing and approving matters for the respective teams. The Code of Conduct must be adhered to in these situations and the Approver must not communicate matters learned from the Company RFP Team with the Company Self-Build Team.

If an Approver feels that he/she cannot manage this potential conflict, the Approver is recommended to consult with his/her immediate supervisor to determine whether such higher authority could be appointed with the task of reviewing and approving matters for a designated team, either the Company RFP Team or the Company Self-Build Team. In matters where a team of employees (including one or more Approvers) is responsible for reviewing and approving matters for the respective teams, approving employees (from whatever level, including executives) with information from reporting personnel beneath them from both the Company RFP Team and the Company Self-Build Team may consider recusing himself/herself from the decision making if such employee cannot objectively make a decision on the matter.

Finally, an Approver may be a member of the Company RFP Team and have a subordinate reporting to him/her that is a member of the Company Self-Build Team (or vice versa). In such situations, because the Code of Conduct prohibits communication between the teams, the Approver must recuse himself/herself from the decision making and request his/her manager to review and approve the matter in his/her place.

In all instances, it is possible that any particular situation above may be addressed and/or resolved by the terms and conditions of the Company's internal code of conduct implemented for all employees and consultants of the Company. As

appropriate, an Approver or any other team member, Energy Contract Manager or Company executive in Charge may involve the Company's Corporate Compliance Officer for input and possible resolution under the Company's internal corporate code of conduct.

V. WHEN THE CODE OF CONDUCT BECOMES EFFECTIVE

A. No later than 30 days after the Commission opens the docket to issue an RFP covered by the Framework, the Code of Conduct for that RFP will be activated. However, if the Company Self-Build Team determines at any time that it will not pursue a self-build option for a particular RFP, the Code of Conduct may be de-activated.

B. Upon the activation of the Code of Conduct, members of the Company RFP Team and the Company Self-Build Team must then conduct activities on the RFP or self-build process in compliance with the Code of Conduct. Once identified and having commenced work, no information may be shared outside the respective team members with respect to the RFP or a self-build option except through the formal communication processes outlined above.

C. Immediately upon assignment to a Company team (RFP or Self-Build), designation as a Shared Resource, or request to assist as an Unassigned Company Resource, each such employee or consultant must review this Manual, and sign the Acknowledgement. Annually, each member of the respective teams, Shared Resources and designated Unassigned Company Resources shall reaffirm their obligations to comply with the Code of Conduct and this Procedures Manual by executing an annual update to the Acknowledgement.

D. Within the RFP process, after a member has been assigned to a particular Company team (RFP or Self-Build), he or she will not be able to transfer to the other Company team during the pendency of any particular RFP (or stage or phase of a particular RFP). It is the responsibility of each team to fill vacant team positions with employees that have not been previously assigned as a team member for a team until the PPA negotiations have been concluded and the final contracts are executed.

E. Each employee and consultant working on the RFP shall review the Code of Conduct and sign the Acknowledgement attesting to his/her compliance with the Code of Conduct for each subsequent year until the Code of Conduct is terminated, or until the employee is no longer working in the position he/she was in while working on the RFP.

F. The Energy Contract Manager will be responsible for maintaining the Roster and the signed Acknowledgements. The Company Executive in Charge shall be responsible for ensuring compliance with the Code of Conduct and shall have the written authority and obligation to enforce the Code of Conduct.

VI. IMMEDIATE ACTIONS UPON ACTIVATION OF THE CODE OF CONDUCT

The following items are required to be completed as soon as possible after activation of the Code of Conduct, but no later than the designated events specified for each item below.

A. No later than 30 days after the opening of the docket commencing an RFP, a Roster listing employee (with their title) and consultants in their designated role; Company RFP Team, Company Self-Build Team, Shared Resource or Unassigned Company Resource. When the IO is appointed, this Roster shall be provided to him/her. The Roster shall be placed in the RFP Communication Tool Kit SharePoint Site so that any Company personnel can access the database to determine the identity of the respective teams and Shared Resources.

B. Upon the finalization of the Roster for the RFP, the Energy Contract Manager shall verify that all employees (whether full-time, part-time, temporary, or contract) and consultants involved in the competitive bidding process, such as members of the Company RFP Team, the Company Self-Build Team, Shared Resources or Unassigned Company Resources, have acknowledged receipt of the Code of Conduct and his or her responsibility to comply with the Code of Conduct by submitting the Acknowledgement (with electronic acknowledgment being acceptable). If an employee

or consultant is later added to a team, the Energy Contract Manager shall also verify that such employee or consultant has submitted the Acknowledgment.

C. No later than 30 days after the opening of the docket commencing an RFP, establishment of the Company email address to accept requests for information from Proposers, including the Company Self-Build Team or any Affiliate Team.

D. No later than 30 days after the opening of the docket commencing an RFP, establishment of the Company-secured site that houses the accessible database (such as SharePoint).

VII. WHEN THE CODE OF CONDUCT TERMINATES

- A. The Code of Conduct for a specific RFP will terminate after the following two conditions are met when:
- a. the final contract(s) for RFPs conducted under the Framework with the successful proposer(s) is/are executed, or when written notice of termination of the RFPs to be conducted under the Framework is provided by the Manager of Energy Procurement or his/her designee to the IO and the Commission, and
 - b. a certification of Code of Conduct compliance by all employees participating in the specific RFP process is submitted by affidavit by the Company Executive in Charge.

VIII. DOCUMENTATION FORMS

The following documentation forms may be utilized by those Company personnel involved in the RFP. These forms may be amended from time to time as necessary. Additional forms may also be developed as determined necessary.

- Competitive Bidding Code of Conduct Acknowledgement of Receipt
- Communications Log
- Roster

IX. APPLICABILITY OF THE ATRs

Except as specifically made applicable under Section V.C.1.i of the ATRs with respect to wholesale power procurement from Affiliates, the ATRs shall not apply to RFP matters covered by the Framework, the Code of Conduct and this Procedures Manual as it relates to the Companies' interactions between the Company RFP Teams and Affiliate Teams. Reference to the ATRs in the Code of Conduct and/or this Manual are specifically for matters outside the Companies' administration of the RFP; provided, however, that such applicability may be revised as necessary and as may be directed by the Commission for any RFP.¹

¹ See Decision and Order No. 35962, filed on December 19, 2018, in Docket 2018-0065, at 56-57.

REQUEST FOR PROPOSALS
FOR
VARIABLE RENEWABLE DISPATCHABLE GENERATION
AND
ENERGY STORAGE
ISLAND OF HAWAI‘I

AUGUST 22, 2019

Docket No. 2017-0352

Appendix D – PowerAdvocate User Information



**Hawai'i
Electric
Light**

Sourcing Intelligence Quick Start for Suppliers

Logging In

1. Launch a web browser and go to www.poweradvocate.com
2. Click the orange **Login** button.
3. Enter your account **User Name** and **Password** (both are case-sensitive) and click **Login**.
4. Click the **Events** tab if it is not already displayed.

Dashboard

Your Dashboard lists the events you have been invited to. A line divides currently accessible events from others.

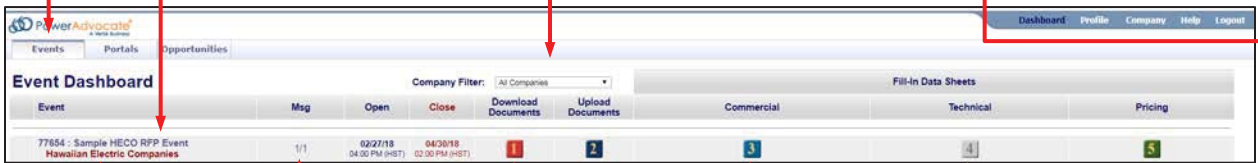

Click to view the event's Status tab

Click to view Events

Buyer filter

Navigation bar

Buying entity

Number of unread/total messages

Click to view the event's Messaging tab

Click numbers to view event tabs

Datasheet available

No datasheet available

Event	Msg	Open	Close	Download Documents	Upload Documents	Commercial	Technical	Pricing
77654 - Sample HECO RFP Event Hawaiian Electric Companies	1/1	02/27/18 04:00 PM (HST)	04/28/18 02:00 PM (HST)	1	2	3	4	5

- Click an event name to view its Status tab, which displays a summary of your activity and key event dates. To view specific details of an event, click the buttons 1-5 to view the corresponding tab.
- To return to the Dashboard, click **Dashboard** in the navigation bar at the top of the window.
- An event will not appear on your Dashboard until you have been added as a participant.



Downloading Bid Packages

All of the Buyer's bid package documents (if any) are centrally stored on the PowerAdvocate Platform. To view bid documents, click "1" on your Dashboard or on the **1. Download Documents** tab from within the event.

Document Description	Issue Date	Ref ID	File Name	File Size	Download
Pre Bid Test Doc	01/15/18		Pre_Bid_Test_Doc.docx	11.63 KB	

- You can access the **Bid** sub-tab after the event opens. You can access Buyer documents before the event is opened from the **Pre-Bid** sub-tab, if the Buyer utilizes this feature.
- To view or download a document, click the file name.
- To download multiple documents:
 1. Select the checkbox in the Download column for each document you wish to download or click **Select All**.
 2. Click **Download Selected Files**.

Uploading Documents

To upload your documents, click "2" on your Dashboard, or on the **2. Upload Documents** tab from within the event.

- Do not upload any files to the Pre-Bid tab.
- To upload a document to the Bid tab:
 1. Specify a **Document Type** (Reference ID can be left blank).
 2. Click **Choose File**, navigate to and select the document, and then click Open; multiple files can also be compressed into one .zip file for upload.
 3. Click **Submit Document**.



Datasheets

Datasheets will not be used in this RFP event. All Proposal information will be uploaded for submission through the 2. Upload Documents tab above. Buttons/tabs are grayed out (e.g., 4) if the event is not using a particular type of datasheet.



Communicating with the Bid Event Coordinator /Company Contact

Suppliers should use the PowerAdvocate Messaging tool to contact the Bid Event Coordinator (BEC) while the bid event is open.

PowerAdvocate Messaging

To send a message to the BEC, go to the **Messaging** tab and click **Create New Message**. To read or reply to a message from the BEC, click the message subject.

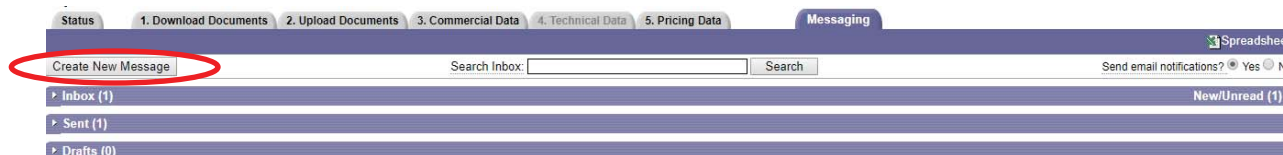

- You can send messages to the BEC and Buyer Team
- The Independent Observer can view all messages in the bid event.
- You can receive external e-mail notification of new PowerAdvocate messages by selecting “Yes” to “Send email notifications?” in the Messaging tab.

Getting More Information

- Click **Help** on the navigation bar to display online help.



- Supplier documentation can be downloaded from the online help system.
- Call PowerAdvocate Support at 857-453-5800 (Mon-Fri, 8 a.m. to 8 p.m. Eastern Time) or e-mail support@poweradvocate.com.

REQUEST FOR PROPOSALS
FOR
VARIABLE RENEWABLE DISPATCHABLE GENERATION
AND
ENERGY STORAGE
ISLAND OF HAWAI‘I

AUGUST 22, 2019

Docket No. 2017-0352

*Appendix E – Mutual Confidentiality and
Non-Disclosure Agreement*



**Hawai'i
Electric
Light**

APPENDIX E
MUTUAL CONFIDENTIALITY AND NON-DISCLOSURE AGREEMENT
Independent Power Producers – (“IPPs”)

This Mutual Confidentiality and Non-Disclosure Agreement (this “Agreement”) is effective as of _____, 20____ (the “Effective Date”) between [INSERT NAME OF IPP], a [State of incorporation/organization] [type of entity] (“IPP”) and Hawaiian Electric Company, Inc., a Hawai‘i corporation (“Company”) and Hawai‘i Electric Light Company, Inc., a Hawai‘i corporation (“Hawai‘i Electric Light”) (Hawaiian Electric and Hawai‘i Electric Light collectively, the Companies). In consideration of the mutual promises contained in this Agreement, including the provision of Confidential Information (as defined below) by either party to the other hereunder, and other good and valuable consideration, the receipt and sufficiency of which are hereby acknowledged, the parties agree as follows:

1. Background

The Companies have or intend to issue a Request for Proposals (“RFP”) for renewable energy generation and/or storage. The IPP has or intends to submit one or more proposals for a nominal [] MW [TYPE OF FACILITY] facility located at [LOCATION] on the island of Hawai‘i, State of Hawai‘i (“Proposal”).

In connection with the IPP’s proposed project, the Companies may conduct an interconnection requirements study (“IRS”) to establish the requirements for interconnection of the IPP’s proposed project to the Companies’ electric grid. The RFP process may also result in the award of a potential power purchase agreement, the terms of which must be agreed upon by the parties (“PPA Negotiations”). For purposes of this Agreement the term “Project” refers to the RFP, Proposal, potential IRS and PPA Negotiations.

In order to evaluate the Project, either party may from time to time provide to the other party certain Confidential Information. The parties are willing to provide such Confidential Information to each other upon the terms and conditions of this Agreement.

2. Confidential Information

Except as set forth in Section 3 (Exclusions from Confidential Information) below, “Confidential Information” means all non-public, confidential or proprietary information disclosed by either party (the “Provider”) to the other party (a “Recipient”) its affiliates and its and their directors, officers, employees, agents, advisors, consultants (including, without limitation, financial advisors, counsel and accountants) and controlling entities or individuals (collectively, “Representatives”) whether disclosed orally or disclosed or accessed in written, electronic or other form of media, and whether or not marked or otherwise identified as “confidential,” including, without limitation:

(a) all information concerning the Provider and its affiliates’, and their customers’, suppliers’ and other third parties’ past, present and future business affairs including, without

limitation, finances, customer information, supplier information, products, services, designs, processes, organizational structure and internal practices, forecasts, sales and other financial results, records and budgets, business, marketing, development, sales and other commercial information and strategies;

(b) information concerning the Companies' generation, transmission, and distribution systems (e.g., engineering and operating characteristics of the Companies' transmission lines and substations) ("Critical Infrastructure Confidential Information");

(c) the Provider's unpatented inventions (whether or not they are patentable), ideas, methods and discoveries, techniques, formulations, development plans, trade secrets, know-how, unpublished patent applications and other confidential intellectual property;

(d) all designs, specifications, documentation, components, source code, object code, images, icons, audiovisual components and objects, schematics, drawings, protocols, processes, and other visual depictions, in whole or in part, of any of the foregoing;

(e) any third-party confidential information included with, or incorporated in, any information provided by the Provider to the Recipient or its Representatives; and

(f) all notes, analyses, compilations, reports, forecasts, studies, samples, data, statistics, summaries, interpretations and other materials ("Notes") prepared by or for the Recipient or its Representatives that contain, are based on, or otherwise reflect or are derived from, in whole or in part, any of the foregoing.

3. Exclusions from Confidential Information

Except as required by applicable federal, state, or local law or regulation, the term "Confidential Information" as used in this Agreement shall not include information that:

(a) at the time of disclosure is, or thereafter becomes, generally available to and known by the public other than as a result of, directly or indirectly, any violation of this Agreement by the Recipient or any of its Representatives; provided, however, that Confidential Information shall not be disqualified as Confidential Information (i) merely because it is embraced by more general or generic information which is in the public domain or available from a third party, or (ii) if it can only be reconstructed from information taken from multiple sources, none of which individually shows the whole combination (with matching degrees of specificity);

(b) at the time of disclosure is, or thereafter becomes, available to the Recipient on a non-confidential basis from a third-party source, provided that such third party is not and was not prohibited from disclosing such Confidential Information to the Recipient by a contractual or other obligation to the Provider;

(c) was known by or in the possession of the Recipient or its Representatives, as established by documentary evidence, prior to being disclosed by or on behalf of the Provider pursuant to this Agreement;

(d) was or is independently developed by the Recipient, as established by documentary evidence, without reference to or use of, in whole or in part, any of the Provider's Confidential Information; or

(e) was or is learned or established entirely from public sources, as established by documentary evidence, without reference to or use of, in whole or in part, any of the Provider's Confidential Information.

The parties acknowledge and understand that the confidentiality obligations of this Agreement apply only to the Confidential Information shared in connection with the Project. The parties may share other information with each other under other agreements, provisions or understandings which are not related to the Project. Such information sharing shall be subject to the provisions of the agreements and confidentiality provisions associated thereto and this Agreement shall not be construed to infringe upon or apply to such agreements or provisions.

4. Non-Disclosure of Confidential Information

Unless otherwise agreed to in writing by the Provider, the Recipient agrees as follows:

(a) except as required by law, not to disclose or reveal any Confidential Information to any person or entity other than its Representatives who are actively and directly participating in the evaluation of the Project or who otherwise need to know the Confidential Information for the purpose of evaluating the Project.

(b) not to use Confidential Information for any purpose other than in connection with its evaluation of the Project or the consummation of the Project.

(c) except as required by law, not to disclose to any person or entity (other than those of its Representatives who are actively and directly participating in the evaluation of the Project or who otherwise need to know for the purpose of evaluating the Project) any information about the Project, or the terms or conditions or any other facts relating thereto, including, without limitation, the fact that discussions are taking place with respect thereto or the status thereof, or the fact that Proprietary Information has been made available to the Recipient or its Representatives.

(d) to use diligent efforts to safeguard and protect the confidentiality of the Confidential Information, including, at minimum, implementing the same commercial measures that the Recipient uses to protect its own confidential information. Before disclosing the Confidential Information to any Representative, the Recipient will inform such Representative of the confidential nature of such information, their duty to treat the Confidential Information in accordance with this Agreement and shall ensure that such Representative is legally bound by the

terms and conditions of this Agreement or subject to confidentiality duties or obligations to the Recipient that are no less restrictive than the terms and conditions of this Agreement.

(e) Any provision herein to the contrary notwithstanding, the Companies may disclose Confidential Information to the State of Hawai'i Public Utilities Commission ("Commission") and/or the State of Hawai'i Division of Consumer Advocacy (including their respective staffs) provided that such disclosure is made under a protective order entered in the docket or proceeding with respect to which the disclosure will be made or any general protective order entered by the Commission.

5. Required Disclosure and Notice

If the parties or any of their Representatives become legally compelled (by deposition, interrogatory, request for documents, subpoena, civil investigative demand, court order, or similar process) to disclose any of the Confidential Information, the compelled party shall undertake reasonable efforts to provide the other party with notice within three (3) business days of such requirement or advice prior to disclosure so that the other party may (a) seek a protective order or other appropriate remedy, (b) consult with the other party with respect to the compelled party taking steps to resist or narrow the scope of such requirement or advice, and/or (c) waive compliance, in whole or in part, with the terms of this Agreement. If such protective order or other remedy is not obtained, or the other party waives compliance with the provisions hereof, the compelled party agrees to furnish only that portion of the Confidential Information which it is legally required to so furnish and, at the request of the other party, to use reasonable efforts to obtain assurance that confidential treatment will be accorded such Confidential Information, it being understood that such reasonable efforts shall be at the cost and expense of the party whose Confidential Information has been sought. In any event, neither the IPP nor any of its Representatives will oppose action by the Companies to obtain an appropriate protective order or other reliable assurance that confidential treatment will be accorded the Confidential Information.

6. Return or Destruction of Confidential Information

At any time during or after the term of this Agreement, at the Provider's written request, and in any event, upon the termination of the Agreement, the Recipient shall certify within ten (10) business days that it has destroyed all Confidential Information by using industry standard data elimination methods used to prevent unauthorized disclosure of information, and for Personally Identifiable Information (defined as personally identifiable information of individuals, and any information that may be used to track, locate or identify such individuals (or which is otherwise protected by privacy laws), including any automatically generated information (such as IP addresses and other customer identifiers) that identifies or is unique or traceable to a particular individual or computer or other electronic device capable of accessing the internet, including without limitation, name, address, telephone number, social security number, credit card account numbers, email addresses, user identification numbers or names and passwords, which is disclosed to the Recipient or its subcontractors in connection with this Agreement by the Provider, which products and services are used or intended to be used for personal, family or household purposes), such methods shall be consistent with Hawaii Revised Statute 487-R;

provided, however, that with respect to Confidential information in tangible form, the Recipient may return such Confidential Information to the Provider within ten (10) business days in lieu of destruction. The Recipient's sole obligation with respect to the disposition of any Notes shall be to redact or otherwise expunge all such Confidential Information from such Notes and certify to the Provider that it has so redacted or expunged the Confidential Information. Notwithstanding the foregoing, with respect to any Confidential Information stored in Recipient's disaster recovery backups or other electronic archives, Recipient is not required to destroy such Confidential Information if it would impose a material cost or burden; provided, however, such Confidential Information shall be destroyed when such archives are destroyed in accordance with Recipient's records retention policies.

7. Authority

Each party represents and warrants that it has full power and authority to enter into and perform this Agreement, and the person signing this Agreement on behalf of each has been properly authorized and empowered to enter into this Agreement, understands it and agrees to be bound by it.

8. No Representations or Warranties

Neither the Provider nor any of its Representatives make any express or implied representation or warranty as to the accuracy or completeness of any Confidential Information disclosed to the Recipient hereunder, and the Recipient agrees that it is not entitled to rely on the accuracy or completeness of any Confidential Information. Neither the Provider nor any of its Representatives shall be liable to the Recipient or any of its Representatives relating to or arising from the use of any Confidential Information or for any errors therein or omissions therefrom. Notwithstanding the foregoing, the Recipient shall be entitled to rely solely on such representations and warranties regarding Confidential Information as may be made to it in any final agreement relating to the Project, subject to the terms and conditions of such agreement.

9. No Other Obligations

Neither this Agreement nor the disclosure of the Confidential Information shall result in any obligation on the part of either party to enter into any further agreement with the other with respect to the subject matter hereof or otherwise, to purchase any products or services from the other, or to require either party to disclose any further information to the other. Nothing in this Agreement shall be deemed to constitute either party hereto as partner, agent or representative of the other party or to create any fiduciary relationship between the parties. Either party may offer products or services which are competitive with products or services now offered or which may be offered by the other. Subject to the express terms and conditions of this Agreement, neither this Agreement nor discussions and/or communications between the parties will impair the right of either party to develop, make, use, procure, and/or market any products or services, alone or with others, now or in the future, including those which may be competitive with those offered by the other. Whether or not the Project is consummated, neither party shall issue a press release or release any information to the general public concerning such transaction or the absence thereof without the express prior written consent of the other, and the parties agree that neither

party will use the other's name whether by including reference to the other in any press release, list of customers advertising that its services are used by Companies or otherwise, without written authorization by the respective party's authorized representative.

10. Property Rights in Confidential Information

All Confidential Information shall remain the sole and exclusive property of the Provider and nothing in this Agreement, or any course of conduct between the parties shall be deemed to grant to the Recipient any license or rights in or to the Confidential Information of the Provider, or any part thereof. Unless otherwise expressly agreed in a separate license agreement, the disclosure of Confidential Information to the Recipient will not be deemed to constitute a grant, by implication or otherwise, of a right or license to the Confidential Information or to any patents or patent applications of the Provider.

11. Publicly Traded Companies

The IPP acknowledges that the Companies' holding company is a publicly traded company, and that Confidential Information of the Companies may constitute material, non-public information with respect to the Companies. The IPP understands, and will advise its Representatives to whom Confidential Information of the Companies is disclosed, of the restrictions imposed by the United States securities laws on (a) the purchase or sale of securities by any person in possession of material, non-public information with respect to such securities, and (b) the communication of material, non-public information with respect to securities to a person who may purchase or sell such securities in reliance upon such information.

12. Remedies

(a) Each party acknowledges and agrees that any breach or threatened breach of this Agreement may give rise to an irreparable injury to the Provider or its Representatives, for which compensation in damages is likely to be an inadequate remedy. Accordingly, in the event of any breach or threatened breach of this Agreement by the Recipient or its Representatives, the Provider shall be entitled to seek equitable relief, including in the form of injunctions and orders for specific performance, in addition to all other remedies available at law or in equity.

(b) In the event that the Recipient learns of dissemination, disclosure, or use of the Confidential Information which is not permitted by this Agreement, the Recipient shall notify the Provider immediately in writing and shall use reasonable efforts to assist the Provider in minimizing damages from such disclosure. Such remedy shall be in addition to and not in lieu of any other rights or remedies available to the Provider at law or in equity.

13. Cumulative Remedies

No rights or remedy herein conferred upon or reserved to either party hereunder is intended to be exclusive of any other right or remedy, and each and every right and remedy shall be cumulative and in addition to any other right or remedy under this Agreement, or under applicable law, whether now or hereafter existing.

14. Notice

(a) By delivering written notice, either party may notify the other that it no longer wishes to receive or provide Confidential Information. Any further information received or provided by the party who received such notice following receipt of such notice, shall not be subject to the protection of this Agreement.

(b) All notices, consents and waivers under this Agreement shall be in writing and will be deemed to have been duly given when (i) delivered by hand, (ii) sent by electronic mail ("E-mail") (provided receipt thereof is confirmed via E-mail or in writing by recipient), (iii) sent by certified mail, return receipt requested, or (iv) when received by the addressee, if sent by a nationally recognized overnight delivery service (receipt requested), in each case to the appropriate addresses and E-mail Addresses set forth below (or to such other addresses and E-mail addresses as a party may designate by notice to the other party):

(1) Companies:

By Mail:

Hawai'i Electric Light Company, Inc.
P.O. Box 1027
Hilo, HI 96721-1027
Attn: Sharon Hirai, System Operation & Planning Department

Delivered By Hand or Overnight Delivery:

Hawai'i Electric Light Company, Inc.
54 Halekauila St.
Hilo, HI 96720
Attn: Sharon Hirai, System Operation & Planning Department

By E-mail:

Hawai'i Electric Light Company, Inc.
Attn: Sharon Hirai, Manager, System Planning & Renewable
Acquisition
Email: sharon.hirai@hawaiielectriclight.com

With a copy to:

By Mail:

Hawaiian Electric Company, Inc.
Legal Division
P.O. Box 2750
Honolulu, Hawaii 96840

Delivered By Hand or Overnight Delivery:

Hawaiian Electric Company, Inc.
American Savings Bank Tower
1001 Bishop Street, Suite 1100
Honolulu, Hawaii 96813
Attn: Legal Division

By E-mail:

Hawaiian Electric Company, Inc.
Legal Division
Email: legalnotices@hawaiianelectric.com

(2) [IPP]

By Mail:

[INSERT ADDRESS/CONTACT]

Delivered By Hand or Overnight Delivery:

[INSERT ADDRESS/CONTACT]

By E-mail:

[INSERT ADDRESS/CONTACT]

With a copy to:

By Mail:

[INSERT ADDRESS/CONTACT]

Delivered By Hand or Overnight Delivery:

[INSERT ADDRESS/CONTACT]

By E-mail:

[INSERT ADDRESS/CONTACT]

15. No Waiver

Except as otherwise provided in this Agreement, no delay or forbearance of a party in the exercise of any remedy or right will constitute a waiver thereof, and the exercise or partial exercise of a remedy or right shall not preclude further exercise of the same or any other remedy or right.

16. Governing Law

This Agreement is made under, governed by, construed and enforced in accordance with, the laws of the State of Hawaii. Any action brought with respect to the matters contained in this Agreement shall be brought in the federal or state courts located in the State of Hawaii. Each party agrees and irrevocably consents to the exercise of personal jurisdiction over each of the parties by such courts and waives any right to plead, claim or allege that the State of Hawaii is an inconvenient forum or improper venue. Notwithstanding the foregoing, Companies, at its option, may elect to submit any such dispute to binding arbitration pursuant to the commercial arbitration rules of Dispute Prevention & Resolution, Inc. or the American Arbitration Association then in effect in which case the parties agree that any alternative dispute resolution shall take place in the State of Hawaii.

17. Attorneys' Fees and Costs

If there is a dispute between the parties and either party institutes a lawsuit, arbitration, mediation or other proceeding to enforce, declare, or interpret the terms of this Agreement, then the prevailing party in such proceeding shall be awarded its reasonable attorneys' fees and costs.

18. Assignment Prohibited

This Agreement shall be binding upon and inure to the benefit of the parties hereto and their respective successors, legal representatives, and permitted assigns. Neither party shall have the right to assign any of its rights, duties or obligations under this Agreement, by operation or law or otherwise, without the prior written consent of the other party. Any purported assignment in violation of this section shall be null and void.

19. No Third Party Beneficiaries

Nothing expressed or referred to in this Agreement will be construed to give any person or entity other than the parties any legal or equitable right, remedy, or claim under or with respect to this Agreement or any provision of this Agreement. This Agreement and all of its provisions and conditions are for the sole and exclusive benefit of the parties and their successors and permitted assigns.

20. Entire Agreement

This Agreement constitutes the entire agreement between the Parties relating to the subject matter hereof, superseding all prior and contemporaneous agreements, understandings or undertakings, oral or written with respect to the subject matter. Any amendment or modification of this Agreement or any part hereof shall not be valid unless in writing and signed by the Parties. Any waiver hereunder shall not be valid unless in writing and signed via by the Party against whom waiver is asserted.

21. Term and Survival

This Agreement shall remain in full force and effect for a period of two (2) years from the Effective Date. All confidentiality obligations within this agreement shall survive following expiration or termination of this Agreement.

22. Severability

If any term or provision of this Agreement, or the application thereof to any person, entity or circumstances is to any extent invalid or unenforceable, the remainder of this Agreement, or the application of such term or provision to persons, entities or circumstances other than those as to which it is invalid or unenforceable, shall not be affected thereby, and each term and provision of this Agreement shall be valid and enforceable to the fullest extent permitted by law, and the parties will take all commercially reasonable steps, including modification of the Agreement, to preserve the economic "benefit of the bargain" to both parties notwithstanding any such aforesaid invalidity or unenforceability.

23. Negotiated Terms

The parties agree that the terms and conditions of this Agreement are the result of negotiations between the parties and that this Agreement shall not be construed in favor of or against any party by reason of the extent to which any party or its professional advisors participated in the preparation of this Agreement.

24. Counterparts and Electronic Signatures

This Agreement may be executed in counterparts, each of which shall be deemed an original, and all of which shall together constitute one and the same instrument binding all Parties notwithstanding that all of the Parties are not signatories to the same counterparts. For all purposes, duplicate unexecuted and unacknowledged pages of the counterparts may be discarded and the remaining pages assembled as one document. The parties agree that this Agreement and any subsequent writings, including amendments, may be executed and delivered by exchange of executed copies via E-mail or other acceptable electronic means, and in electronic formats such as Adobe PDF or other formats mutually agreeable the parties which preserve the final terms of this Agreement or such writing. A party's signature transmitted by E-mail or other acceptable electronic means shall be considered an "original" signature which is binding and effective for all purposes of this Agreement.

[Signature Page Follows]

IN WITNESS WHEREOF, each party has caused this Agreement to be executed on its behalf by a duly authorized representative, all as of the Effective Date.

HAWAIIAN ELECTRIC COMPANY, INC.
("HAWAIIAN ELECTRIC")

By: _____
Print Name: _____
Its: _____

HAWAI'I ELECTRIC LIGHT COMPANY, INC.
("HAWAI'I ELECTRIC LIGHT")

By: _____
Print Name: _____
Its: _____

[Insert Name of IPP]

("IPP")

By: _____
Print Name: _____
Its: _____

REQUEST FOR PROPOSALS
FOR
VARIABLE RENEWABLE DISPATCHABLE GENERATION
AND
ENERGY STORAGE
ISLAND OF HAWAI‘I

AUGUST 22, 2019

Docket No. 2017-0352

Appendix F – Description of Available Sites

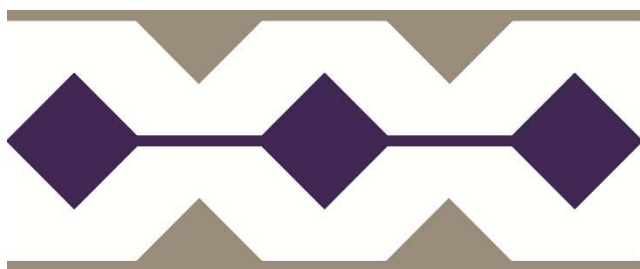

**Hawai‘i
Electric
Light**

APPENDIX F
VARIABLE RENEWABLE DISPATCHABLE GENERATION AND ENERGY STORAGE
DESCRIPTION OF AVAILABLE SITES

Land Request for Information

On December 12, 2016, the Hawaiian Electric Companies issued a Land Request for Information (“Land RFI”) seeking information on available land for potentially siting future utility scale renewable energy projects on the islands of O‘ahu, Maui, Moloka‘i, Lana‘i, and Hawai‘i. Information from responding landowners is available upon request by following the instructions at <http://hawaiielectriclight.com/landrfi>. Several updates have been made to the information that was previously distributed in advance of the Companies’ last round of RFPs. These include updated hosting capacity values that take into account the current state of each of the island systems, some additional land parcels, as well as a few corrections to the Companies’ infrastructure depicted on the maps.

This information is being provided for proposers’ consideration only. Project proposals submitted in response to this RFP are not required to be sited at a location identified through the Land RFI. Hawaiian Electric also makes no representations as to the suitability of the listed sites for renewable energy production with regard to resource quality, interconnection constraints, zoning and permitting issues, community support, or other issues. Proposers should perform their own evaluation of these factors in determining whether a site is suitable for renewable energy project development. After further evaluation, proposers that are interested in any of the identified Land RFI parcels are invited to engage in further discussions directly with landowners to negotiate any required rights to use the property.

Company-Owned Sites – Keahole and Puna Sites

Two Company-owned Sites, referred to as the Keahole Site and the Puna Site (“Company Sites”) are being offered to Proposers for nominal consideration to site standalone storage facilities. Maps of the available areas within each generating station are included as Attachments 1 and 3 to this Appendix F. A topographical diagram of the Keahole Site showing elevation lines for the available area is also included as Attachment 2 to this Appendix F.

Any Proposer proposing to use the Company Sites shall be required to agree to specific terms and conditions for such use as provided for in an attachment to the ESPPA. A draft copy of the proposed form of the Terms and Conditions for Use (“TCU”) is included as Attachment X to the ESPPA. Limited sections of the TCU, relating to use restrictions, security and infrastructure requirements, compliance with laws, lien restrictions and end of term obligations shall be non-negotiable.

Upfront costs to the Proposer associated with the Company Sites include the following: (1) a baseline assessment of the selected Site, either a Phase 1 or Phase 2 environmental assessment; and (2) applicable physical and data security requirements. Ongoing costs are customary and reserved in the TCU and the ESPPA (insurance costs, security costs, etc.). See the ESPPA and Attachment X for details on these upfront and ongoing use costs.

The specified costs above are not exhaustive, and the Proposer is encouraged to review the TCU to determine all associated use costs. Proposers should perform their own evaluation and account for all

possible costs and should not rely solely on the identified costs noted above. Proposer also shall be responsible, at its sole cost and expense, for all site improvements, utilities, permits, and other required infrastructure and regulatory requirements that are necessary for use of the Company Sites for Proposer's Project.

The Company provided potential Proposers an opportunity to visit both sites on August 7, 2019. Information from the site visits will be posted on the Company's RFP website.

The Company is also willing to share a soils report concerning the Puna Site with interested Proposers. Requests for a copy of this report must be sent to the RFP email address, and the report will be made available to Proposers only after execution of a Non-Disclosure Agreement. Any drawings, reports, or any other information or data relating to the Sites ("Site Information") are being furnished for the Proposer's convenience only and the Company assumes no responsibility whatsoever in respect to the sufficiency or accuracy of such Site Information or of the interpretation thereof, and there is no guaranty, either expressed or implied, that the conditions indicated are representative of those existing throughout the Site. In addition, no assurance is given that conditions found at the time of any surface or subsurface explorations will be the conditions that prevail at the time of construction at the Site. The Proposer shall be solely responsible for all assumptions, deductions, or conclusions the Proposer may make or derive from the information furnished. Making such information available to the Proposer is not to be construed in any way as a waiver of the Proposer's responsibility to examine the Request for Proposals and the Site. Proposers must satisfy itself through its own investigation as to conditions to be encountered at the Site.

Keahole Site

The Keahole Site is a partially developed site located within the Keahole Generating Station near the Kona International Airport and shown in the Appendix F Attachment 1 diagram. Interconnection at the Keahole Site requires the construction of two 69 kV breakers, additional 69 kV switches, and associated bus work to satisfy the Keahole Switching Station's breaker-and-a-half arrangement. Associated work required for the interconnection will also include site preparation, the extension of two 69 kV substation buses, grounding installation, and fencing work. Proposers should note that there is a noise restriction from the State Department of Health of 55 dB at the Station's property line. Noise is allowed to be higher than 55 dB within the property, but it must be mitigated to be at or lower than 55 dB at the Station's property line. Additionally, because the Keahole Site is located within a Company secured area, any non-Company personnel that will be working at the Keahole Site will be required to attend a Company safety orientation and have a background check performed in order to work on the Keahole Site.

Puna Site

The Puna Site is a partially developed site located within the Company's Puna Station as shown in the Appendix F Attachment 3 diagram. While the most cost effective interconnection approach would need to be further studied, interconnection at the Puna Site may be proposed on the 13.8 kV side of the existing 33 MVA Puna Steam transformer. For this approach, no ground grid extension is needed, however new underground duct lines to the interconnection point and an additional 13.8 kV breaker on the Proposer's side are required. There is also no open wire/open bus construction, therefore all potential connection points would need to be between the transformer and switchgear. Proposers should be aware that the substation is small and congested which may present challenges for construction to avoid existing

underground duct banks and other infrastructure. Additionally, vehicular access to the Puna Site is narrow, and Proposers should keep in mind that the route may be difficult for larger vehicles to access. Similar to the Keahole Site, because the Puna Site is located within a Company secured area, any non-Company personnel that will be working at the Puna Site will be required to attend a Company safety orientation and have a background check performed in order to work on the Puna Site.

Additional Information

Additionally, the following links to a few publicly available resources relating to renewable energy project siting and development from the Hawaii State Energy Office are being provided for use at proposers' sole discretion:

Project Permitting Assistance and Resources

<http://energy.hawaii.gov/developer-investor/project-permitting-assistance-and-resources>

Provides numerous resources to support more informed and appropriate project siting and permitting, including the Permit Guide, Renewable Energy Permitting Consultants, DOH, ePermitting Portal, Renewable EnerGIS, Permitting Wizard, and the Renewable Energy Projects Directory.

Hawaii Clean Energy Programmatic Environmental Impact Statement

<http://energy.hawaii.gov/testbeds-initiatives/hawaii-clean-energy-peis/peis-overview>

The Hawaii Clean Energy Programmatic Environmental Impact Statement (PEIS) analyzes, at a programmatic level, the potential environmental impacts of clean energy activities and technologies in the following clean energy categories: (1) Energy Efficiency, (2) Distributed Renewables, (3) Utility-Scale Renewables, (4) Alternative Transportation Fuels and Modes, and (5) Electrical Transmission and Distribution

Hawaii Statewide GIS Program

<http://planning.hawaii.gov/gis/>

Provides Hawaii GIS data and other resources to support site identification and analysis

Aloha Aina: A Framework for Biocultural Resource Management in Hawai'i's Anthropogenic Ecosystems

https://nmshawaiihumpbackwhale.blob.core.windows.net/hawaiihumpbackwhale-prod/media/archive/council/pdfs/aloha_aina.pdf

A framework developed by the Hawaiian Islands Humpback Whale National Marine Sanctuary Advisory Council to integrate Native Hawaiian and Western scientific management approaches toward ecosystem management. While intended for the Sanctuary, this document provides useful insight into successful collaboration in Hawaii.

Hawaii Island

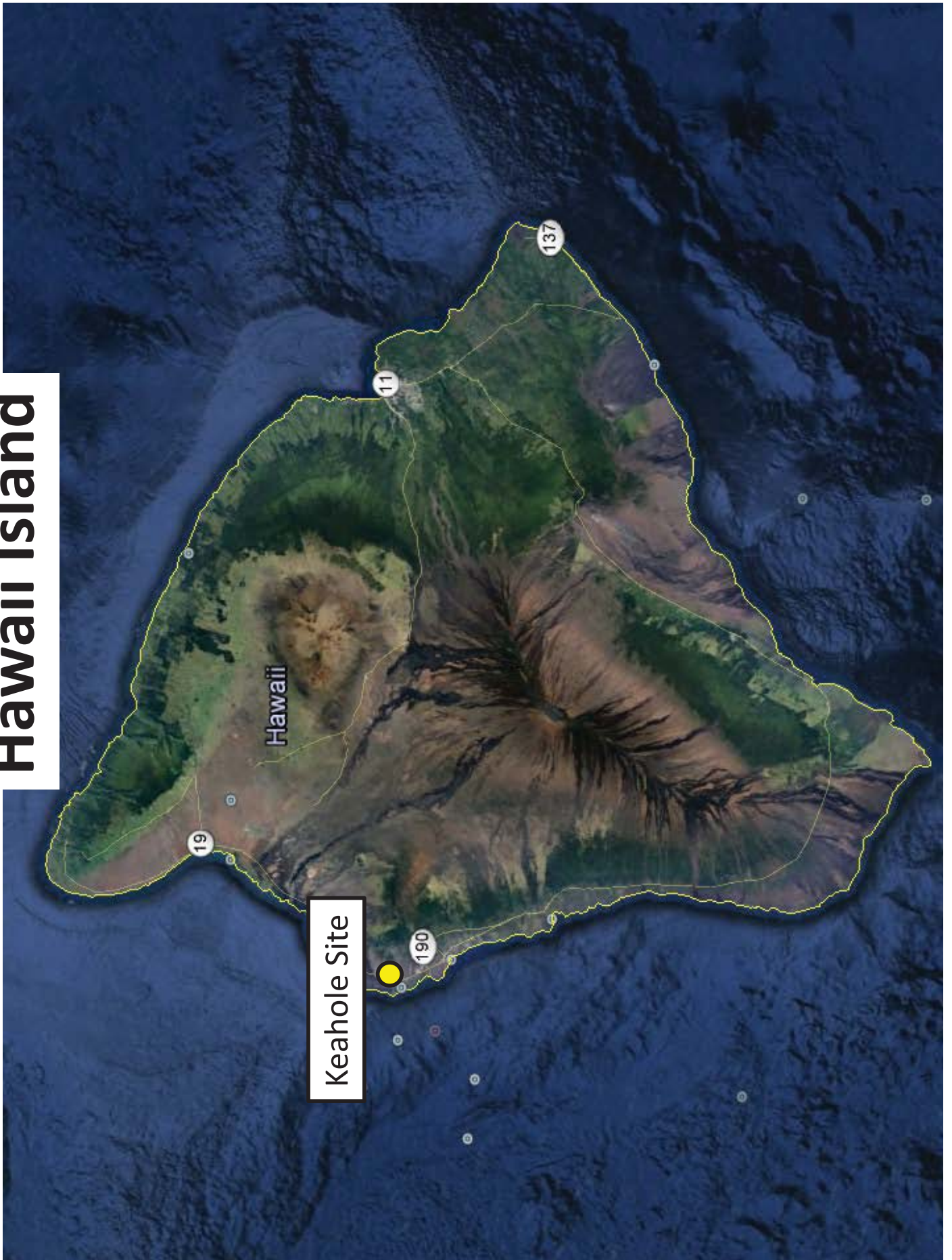

Keahole Site

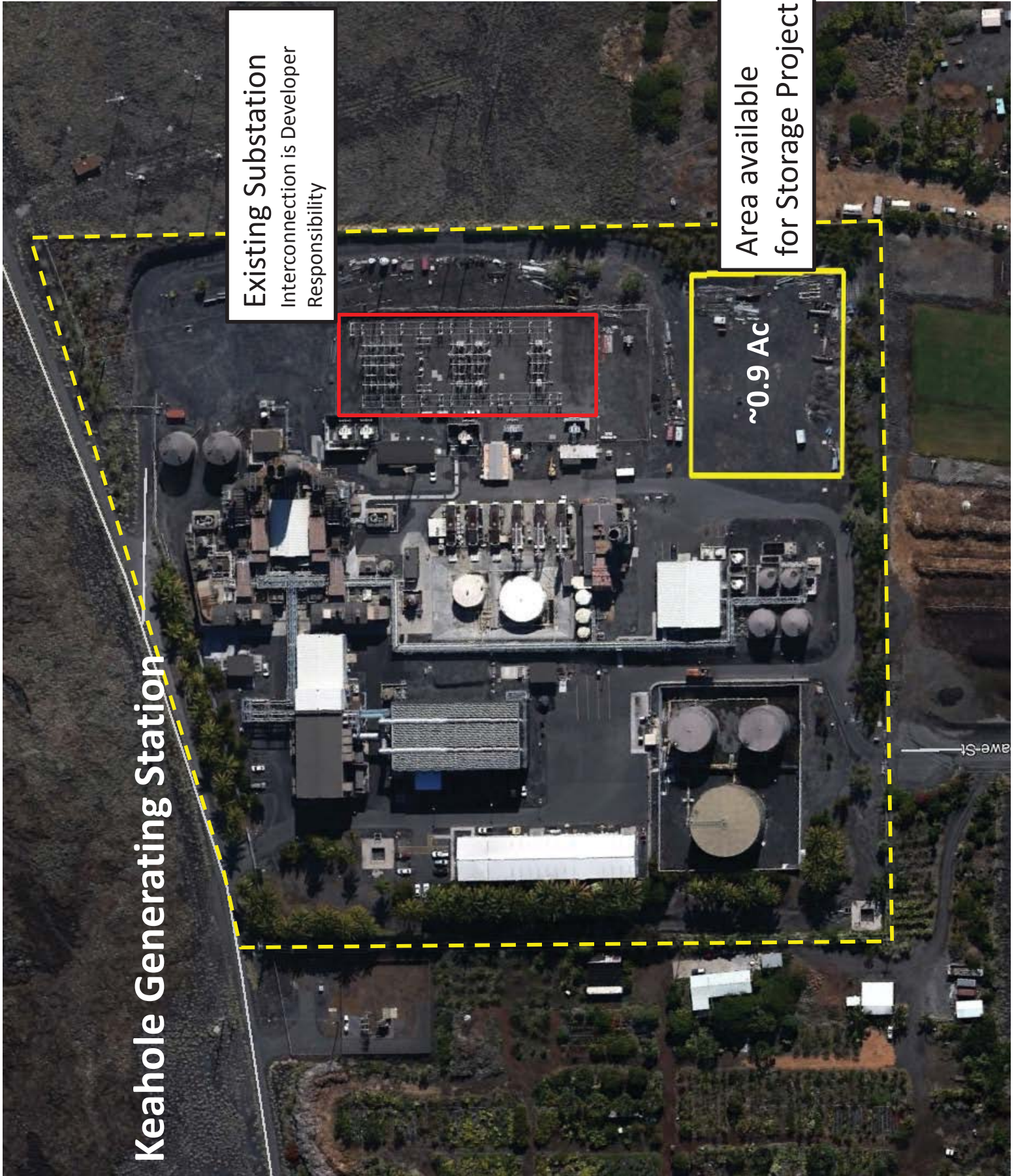

Keahole Generating Station

Existing Substation
Interconnection is Developer
Responsibility

**Area available
for Storage Project**

~0.9 Ac

Appendix F Attachment 2

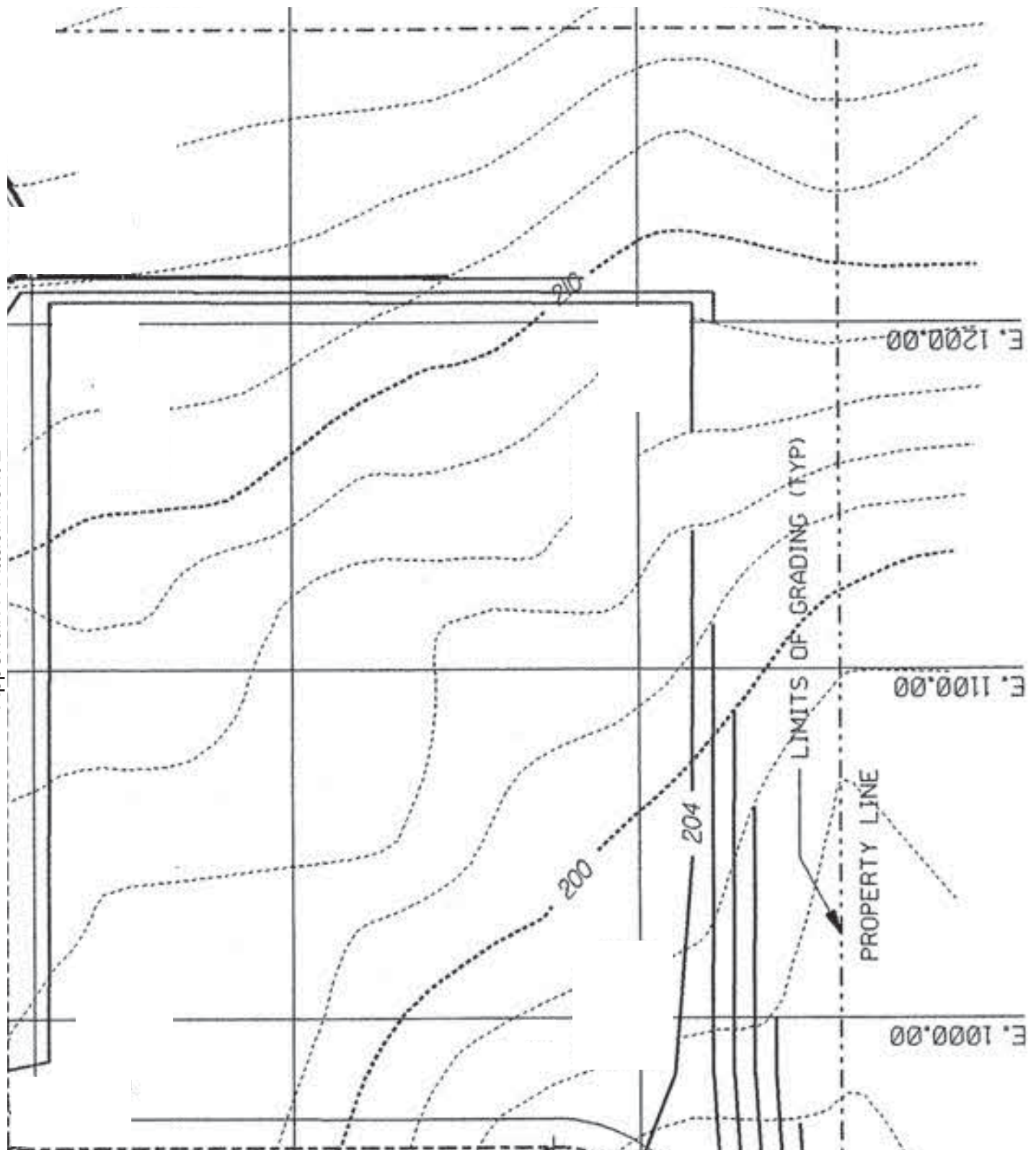

Hawai'i Island



Puna Generating Station

Puna Station Entrance

Area available for
Storage Project

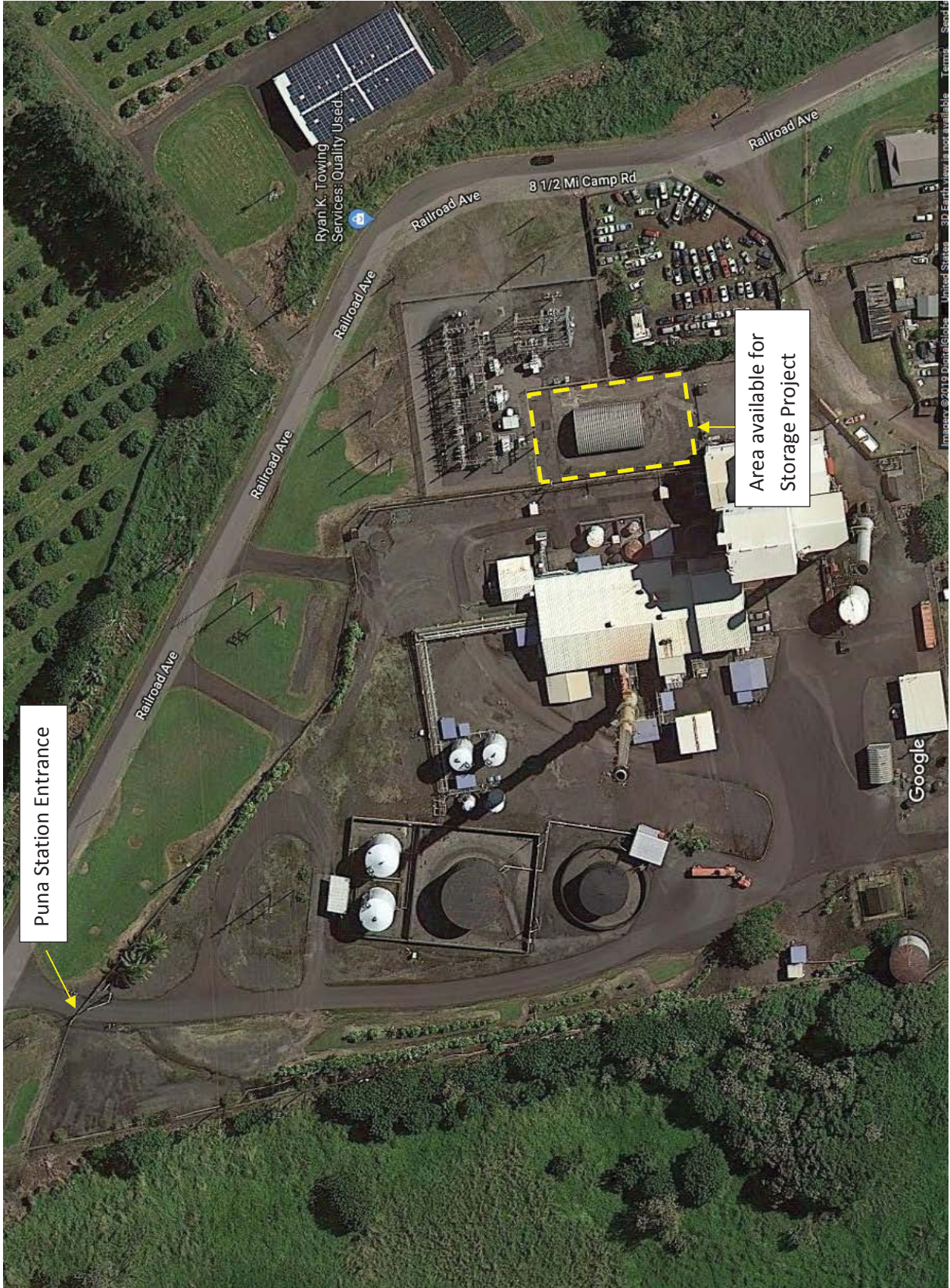

REQUEST FOR PROPOSALS
FOR
VARIABLE RENEWABLE DISPATCHABLE GENERATION
AND
ENERGY STORAGE
ISLAND OF HAWAI‘I

AUGUST 22, 2019

Docket No. 2017-0352

*Appendix G – Self Build Option and
Self Build Option Team Certification Form*



**Hawai'i
Electric
Light**

Appendix G - Self Build Option

Overview

To the extent that there are Self Build Option (“SBO”) Proposals to the RFP, the Company will endeavor to evaluate these SBO Proposals on a fair basis compared to third party Proposals. As described in Section 1.9 of the RFP, “[t]he Competitive Bidding Framework allows the Company the option to offer a Proposal(s) in response to this RFP (“Self-Build Option” or “SBO”). Accordingly, the Company must follow certain requirements and procedures designed to safeguard against and address concerns associated with: (1) preferential treatment of the SBO or members, agents or consultants of the Company formulating the SBO (the “Self-Build Team”); and (2) preferential access to proprietary information to the Self-Build Team.” An SBO Proposal will be required to comply with the provisions in the Framework for Competitive Bidding (“Framework”) as well as this RFP.

In addition to its Proposal, the Self-Build Team will be required to submit Attachment 1 to this Appendix G, Self-Build Option Team Certification Form, acknowledging it has followed the rules and requirements of the RFP to the best of its ability and has not engaged in any collusive actions or received any preferential treatment or information providing an impermissible competitive advantage to the Self-Build Team over other proposers responding to this RFP, as well as adherence to PPA terms and milestones required of all proposers and the SBO’s proposed cost protection measures.

Pursuant to the Framework and as set forth in the RFP Schedule, the Company will require that the Proposal for the SBO(s) be submitted electronically through the Electronic Procurement Platform and a hard copy filed with the PUC a minimum of one (1) Day before other Proposals are due.

Except where specifically noted, an SBO Proposal must adhere to the same price and non-price Proposal requirements as required of all Proposers.

As described in Section 3.8.4 of the RFP, if selected, a Self-Build Proposer will not be required to enter into a PPA with the Company. However, the Self-Build Proposer will be held to the proposed modifications to the RDG PPA and/or ESPPA, if any, it submits as part of the SBO in accordance with Section 3.8.7 of the RFP. Moreover, the SBO will be held to the same performance metrics and milestones set forth in the RDG PPA and/or ESPPA to the same extent as all Proposers, as attested to in the SBO’s Appendix G Attachment 1 Self Build Option Certification submittal. If liquidated damages are assessed, they will be paid from shareholder funds and returned to customers through the Purchased Power Adjustment Clause (“PPAC”),

In lieu of price components, the SBO will need to provide their total project capital costs, any associated annual O&M costs, as well as annual revenue requirements by year. (See Appendix B Section 2.0.) The SBO shall submit revenue requirement worksheets with their Proposal that support their annual revenue requirements estimates. (See Appendix B Section 2.1.) A starter revenue requirements template example is attached as Attachment 2 to this Appendix G. An

Excel template of that file can be requested by the SBO via email to the RFP Email Address or through the PowerAdvocate Messaging function once the RFP even opens. The revenue requirements worksheets submitted will be customized to reflect the details of the Project's Proposal. All assumptions used will be reflected in an assumptions input tab.

SBO Total Project Capital Cost

The following is a high-level breakdown followed by a narrative explanation of the total capital cost estimate for a potential SBO Proposal. The total project capital cost (and annual O&M costs) will be used to calculate the Revenue Requirement, which will then be used to calculate a LEP for Proposal comparison purposes. The categories of costs include:

- Facility
 - EPC Contract
 - Allowance for Change Orders
 - Equipment
 - Owner's Cost
- Outside Services
- Interconnection
- Overheads
- AFUDC

These costs will be identified in Section 2.3.2.2 of the SBO Proposal(s). (See Appendix B Section 2.3.2.2.)

- Facility (including any generation and storage components) - This line item, to the extent applicable, should include costs such as:

Engineering, Procurement, and Construction ("EPC") Contract

The total cost estimate of the facility is the projected EPC contract cost including the design of the facility up to the high-voltage terminals of the step-up transformers, procurement of all the equipment, and services necessary to build the facility and construction and commissioning of the facility.

Allowance for Change Orders

This allocation accounts for items such as additional requirements resulting from unforeseen conditions, unexpected permitting requirements, force majeure events, unanticipated interferences, different interpretations of design requirements, material unavailability, and longer than normal delivery times.

Equipment

This cost includes the generator and the facility equipment that support the operation of the generator and the distribution of electrical power around the station, as applicable. Engineering and testing services required to ensure that the equipment is properly functioning at the site, training and documentation

necessary to operate and maintain the equipment, and performance guarantees may also be included here.

Owner's Cost

Owner's costs for the facility are all the costs necessary for the design, permitting, procurement, construction, and commissioning of the facility and for the preparation of the Proposal that are not included in the major contracts (i.e. EPC). The Companies' Labor includes Project Management, Station Operator training and commissioning, Environmental, Safety, Legal, Corporate Communications, Community and Government Relations, Engineering, and Regulatory Affairs. Company Labor for the preparation of the Proposal is also included here. For purposes of recovery, only the incremental costs of Labor will be subject to separate recovery.

- Outside Services - This line item, to the extent applicable, should include costs such as:
 - Construction Management to oversee the EPC contractor
 - Legal for the preparation of the Environmental Impact Statement and PUC process
 - Engineering for development and evaluation of the project technical specifications, Interconnection Requirements Study (IRS) and emissions testing
 - Environmental to conduct the Environmental Impact Statement (EIS) and Air Permit consulting
 - General Services such as surveys, land appraisals, Environmental Condition Reports, public relations, office trailer rental, archeological services, landscaping, miscellaneous permits, builder's risk insurance, switchgear testing, hazard analysis, painting, monitoring services, and moving costs.
 - Material costs including spare parts, furnishings, IT equipment, appliances, generator system initial fills (fuels, oils, water), and telecommunications equipment for the station.
 - Travel costs required to inspect other similar facilities, observe final acceptance testing of critical equipment, and station operators' factory training

- Interconnection – This line item covers all interconnection costs that a similarly situated IPP would be responsible for as described in RFP Section 2.3.5, and to the extent applicable, should include costs such as:

Transmission Line

The cost estimate includes the design, procurement, and construction of any new transmission infrastructure needed to interconnect with the designated substation.

Switchyard

Work at the switchyard will include design, procurement, and construction of the switchyard and the interfaces between the high voltage terminals of the generator step-up transformers and the transmission line to which it will be connected. Site preparation of the switchyard and the design, procurement, and installation of the step-up transformers located in the switchyard, are typically included in the EPC contract.

Substation

Work at the designated substation that will include the design, procurement, and construction of the interfaces between the new transmission line and the substation buswork to which it will be connected.

Telecom

Accounts for direct labor, materials, and outside services to install telecommunication requirements for the project.

Project Management

Cost estimate of the project management design, procurement, contracting, and scheduling efforts for the interconnection only. Project management costs for the facility are included in the Owner's Cost estimate above.

- Overhead Costs

Overhead costs for the proposed facility will be estimated by the Company's budgeting software (UI Planner) and represent an allocation for those Company costs that are not attributable to any particular project or operation, but are essential nonetheless. Overheads are comprised of non-productive wages (such as holiday, sick, and vacation pay), employee benefits, payroll taxes, corporate administrative costs, and clearing costs.

- Allowance for Funds Used During Construction ("AFUDC")

The AFUDC will be calculated using the Company's budgeting software (UI Planner) and represents the cost of capital funding for the Project. The Company strives to minimize the cost of the AFUDC by ensuring that Project elements that are used or useful are placed in service as soon as possible, as well as minimizing the amount of time that AFUDC can accumulate, by minimizing the amount of time between expenditures on Project elements and their placement in service.

The SBO Proposal will include a Revenue Requirement for each year, which is calculated from the total project capital cost to determine the revenues needed to recover the cost of the project. The value of the Revenue Requirement Calculation for the Total SBO Project Capital Cost will be included in the Levelized Price calculation described below.

Annual O&M

The cost for ongoing O&M (fixed and variable) will be a component of the Revenue Requirement. All O&M should be included in this category, unless captured elsewhere in the Revenue Requirement Calculation, including but not limited to annual O&M expense to maintain facility; property taxes (if applicable), and insurance. As described in RFP Appendix G, a SBO Proposal will be required to cap its O&M costs at the amount included in the Proposal. Only actual costs will be recovered if such actual costs are lower than the maximum amounts in the Proposal.

Annual Revenue Requirement

The SBO Proposal will include a Revenue Requirement for each year, which is calculated from the total project capital cost to determine the revenues needed to recover the cost of the project. The value of the Revenue Requirement Calculation for the Total SBO Project Capital Cost will be included in the Levelized Price calculation.

The following is a narrative description of the proposed revenue requirement calculation and significant assumptions that the SBO Proposal should account for. The objective of a revenue requirement analysis is to illustrate the annual revenue requirements (ARR) for a utility SBO Proposal.

Revenue Requirement is defined as a calculated value which represents the estimated revenues needed from ratepayers which would allow the Company to recover its capital investment and expenses, honor its debt obligations, pay its revenue and income tax liabilities and pay its preferred shareholders while providing a fair return to its common shareholders for their investment. Specific factors or assumptions related to that particular project will be included in the analysis.

The purpose of a revenue requirement calculation is to determine the annual and total revenue requirements of a capital investment and annual O&M expense needed from customers. The ratemaking formula for revenue requirements is shown below.

$$RR = O + T + D + r(RB)$$

Where:

- RR = Revenue Requirements
- O = Operating and Maintenance Expense
- T = Tax Expense (Income and Revenue)
- D = Depreciation Expense
- r = Rate of Return on Rate Base
- RB = Rate Base

The Company, in conjunction with the Independent Observer, may also conduct a risk assessment of the SBO Proposal to ensure an appropriate level of customer cost protection measures are included in such proposal.

APPENDIX G ATTACHMENT 1 - SELF BUILD OPTION TEAM CERTIFICATION

Name of SBO Team Contact: _____

Unique Name of Facility: _____

This Certification of the Self Build Option (SBO) Team’s Proposal for Hawaiian Electric Company, Inc., Maui Electric Company, Ltd, and Hawai’i Electric Light Company, Inc.’s (the “Hawaiian Electric Companies”) Variable Renewable Dispatchable Generation and Energy Storage Stage 2 Request for Proposal (RFP) is made as of the date stated below.

A. COMPLIANCE WITH THE RFP AND CODE OF CONDUCT

The SBO Team certifies and acknowledges that it will/has:

1. Adhered to the terms of the RFP applicable to the SBO Team, including but not limited to: Section 1.7.1 (proposal submittal requirements) , Section 1.7.3 (certification of non-collusion), Section 1.9 (Procedures for the Self-Build or Affiliate Proposals), and Section 3.4.4 (authorized signatory);
2. Adhered to the technical requirements of the RFP, excluding however those requirements inapplicable to the SBO Team such as execution of the Model RDG PPA or Energy Storage PPA (ESPPA), pricing formula requirements for independent power producer proposals, submission of a Proposal Fee, dispute resolution, credit requirements, selection of a priority list, and submission of a best and final offer;
3. Complied with the Company’s Code of Conduct Procedures Manual, attached as Appendix C to this RFP, with particular attention to the Communications Protocols described in Part IV, Section C, therein with respect to communication with the Company RFP Team.

B. INDEPENDENT INVESTIGATION

The SBO Team further certifies and acknowledges that it will/has:

1. Submitted the SBO Proposal based on its own investigations, examinations and determinations, including assessments of any risks that could have an effect on its obligations under the SBO Proposal.
2. Carefully examined the Hawaiian Electric Companies’ Renewable Dispatchable Generation and Energy Storage Stage 2 RFP documents and its appendices and has a clear and comprehensive knowledge of what is required of a Proposer under the RFP, and correspondingly, what is required of the SBO Team.

3. Examined and understands the technical requirements, schedule and evaluation process as it is laid out under the Variable Renewable Dispatchable Generation and Energy Storage Stage 2 RFP.

C. COST PROPOSAL ACKNOWLEDGEMENTS

The Self Build Team acknowledges and agrees that:

1. Recovery for Project capital costs and O&M costs will be capped at the amount included in the SBO Team's Proposal.
2. Only actual capital costs and O&M costs will be recovered even if such actual costs are lower than the SBO Team's proposed maximum amounts.
3. Costs of developing the proposal must be included in the SBO for evaluation purposes only. Only the incremental costs of developing the SBO Team's proposal will be charged to the project and passed through to customers. Incremental costs for SBO proposals not serving as the Parallel Plan and which are not selected to the Final Award Group will not be recoverable from the Companies' customers.

D. ADHERENCE TO PPA REQUIREMENTS AND MILESTONES

The Self Build Team acknowledges and agrees that:

1. The SBO Proposal will be consistent with the scope of work and responsibilities of the "Seller" under the terms of the applicable Model PPA excluding inapplicable terms related to commercial and legal interactions between the Seller and the Company.
2. The SBO Facility will be designed and constructed to:
 - a. Achieve the Performance Standards identified in Section 3 - Performance Standards, in Attachment B of the applicable Model PPA as modified by the IRS (subject to reasonable adjustment agreeable to the Company consistent with the Company's negotiation of such performance standards that would be completed with an independent power producer under similar circumstances);
 - b. Meet the performance metrics as specified in Article 2 of the applicable Model RDG PPA or Article 4 of the ESPPA.
 - b.1. For facilities with a photovoltaic generation component, (i) PV System Equivalent Availability Factor, and (ii) Measured Performance Ratio;
 - b.2. For facilities with a wind generation component, (i) Modified Pooled OMC Equipment Availability Factor, (ii) Performance Index, and (iii) Balance of Plant Efficiency Ratio;
 - b.3. For Storage facilities (paired storage or standalone storage), (i) Storage Annual Equipment Availability Factor, (ii) Storage Annual Equivalent Forced Outage Factor, and (iii) Storage Capacity Ratio;

- c. Pass the Acceptance Test specified in Attachment N – Acceptance Test General Criteria of the applicable Model RDG PPA or ESPPA.
- d. Pass the Control System Performance Test specified in Attachment O – Control System Acceptance Test Criteria of the applicable Model RDG PPA or ESPPA;
- e. If applicable, pass the On-line Performance Test specified in Attachment W – BESS Capacity Test of the applicable Model RDG PPA, or Attachment T – Facility Tests of the Model ESPPA;
- f. If applicable, achieve a Demonstrated Capacity equal to or greater than that indicated in the SBO Proposal as measured pursuant to Attachment W – BESS Capacity Test of the applicable Model RDG PPA;
- g. Meet the project milestones identified in the SBO Proposal no later than the dates specified therein, which shall be consistent with the guaranteed project milestones required in Attachment K – Guaranteed Project Milestones of the Model RDG PPA or ESPPA (subject to reasonable adjustment agreeable to the Company consistent with the Company’s negotiation of such milestones that would be completed with an independent power producer under similar circumstances). Notice of completion of milestones and any delay will be provided to PUC and Consumer Advocate.
- h. Achieve the reporting milestones identified in the SBO Proposal no later than the dates specified therein, which shall be consistent with the reporting milestones required in Attachment L – Reporting Milestones of the Model RDG PPA or ESPPA (subject to reasonable adjustment agreeable to the Company consistent with the Company’s negotiation of such milestones that would be completed with an independent power producer under similar circumstances). Notice of completion of milestones and any delay will be provided to PUC and Consumer Advocate.
- i. Will be subject to the applicable liquidated damages for the PPA or ESPPA provisions above. These liquidated damages would be paid from shareholder funds and would be passed through to customers through the Companies’ Power Purchase Adjustment Clause. Notice of any liquidated damages assessed and amounts of such liquidated damages will be provided to PUC and Consumer Advocate.
- j. Will reconfirm requirements in GO7 application and any resulting approval order for such application.
- k. Will provide annual report to PUC and Consumer Advocate on performance metrics.

E. DECLARATION AND SIGNATURE

- 1. The individual(s) that has (have) signed this Self Build Option Team Certification is (are) duly authorized by the SBO Team to execute such on behalf of the SBO Team; and

2. All statements, specifications, data, confirmations and other information set out in this Self Build Option Team Certification are complete and accurate in all material respects.

IN WITNESS WHEREOF, the SBO TEAM hereby makes the certifications, acknowledgements and agreements stated herein as of the date stated under the signature of its authorized representative:

Dated at _____, _____ this _____ day of _____ 20_____.

Signature of SBO Team Representative

Name of SBO Team Representative (please print)

Title of SBO Team Representative (please print)

Project Name
Summary

<u>Year</u>		<u>Revenue Requirement</u>
1		50
2		150
3		144
4		138
5		132
6		126
7		121
8		116
9		110
10		105
11		100
12		99
13		93
14		87
15		82
16		76
17		72
18		68
19		64
20		60
21		(0)
22		(0)
23		(0)
24		(0)
25		(0)
26		(0)
27		(0)
28		(0)
29		(0)
30		(0)
31		(0)
32		(0)
33		(0)
34		(0)
35		(0)
36		(0)
37		(0)
38		(0)
39		(0)
40		(0)
41		(0)
42		(0)
43		(0)
44		(0)
45		(0)
46		(0)
47		(0)
48		(0)
49		(0)
50		(0)
51		(0)
52		(0)
53		(0)
54		(0)
55		(0)
56		(0)
57		(0)
58		(0)
59		(0)
60		(0)
Total		1,992
NPV @	3.00%	1,531
NPV @	7.03%	1,127
NPV @	12.00%	821

Project Name
Revenue Requirements Model
Assumptions

Manual input

HECO TY2017 Rate Case Dkt 2016-0328 Final D&O 35545

Cost of Capital Assumptions

	Weight	Rate	Weighted Average	After-Tax Weighted Average	Weighted Average Revenue Requirement	Weighted Average Gross-up for Income Taxes
Short Term Debt	1.18%	1.75%	0.02%	0.02%	0.023%	0.02%
Long Term Debt (Taxable Debt)	39.59%	5.03%	1.99%	1.48%	2.186%	1.99%
Hybrids	1.22%	7.19%	0.09%	0.07%	0.096%	0.09%
Preferred Stock	0.90%	5.37%	0.05%	0.05%	0.072%	0.07%
Common Stock	57.10%	9.50%	5.42%	5.42%	8.018%	7.31%
	100.00%		7.57%	7.032%	10.395%	9.471%

Tax Assumptions

		Effective	
Federal Income Tax Rate	21.00%	19.74%	
State Income Tax Rate	6.40%	6.02%	
		25.75%	
State Investment Tax Credit (ITC)		4.00%	
Accelerated State ITC Amortization Period ¹		10	
Public Service Company Tax		5.885%	
PUC Fee		0.500%	
Franchise Tax		2.500%	
Composite Revenue Tax Rate		8.885%	1.09751

Project Assumptions

Capital Investment \$ 1,000

Depreciation

Expected Useful Life	20	
MACRS Tax Life ("Tax Life")	15	half-year convention, table A-1
Tax Class Life ("Class Life")	20	half-year convention, table A-8

O&M

O&M \$ -

Escalation Rate 2.0%

Notes:

1. Per HECO 2017 TY Rate Case Parties' Stipulated Settlement Letter in Docket No. 2016-0328, State ITC Amortization accelerated over a ten-year period.

Project Name	Tax Depreciation																										
Tax Depreciation Factors	1	2	3	4	5	6	7	8	9	10	11	12	13	14	15	16	17	18	19	20	21	22	23	24	25	26	
Manual Input	Years																										
Tax Depreciation Rates (Straight Line)																											
-																											
3	16.7%	33.3%	33.3%	16.7%																							
5	10.0%	20.0%	20.0%	20.0%	10.0%																						
7	7.1%	14.3%	14.3%	14.3%	14.3%	14.3%	14.3%	7.1%																			
10	5.0%	10.0%	10.0%	10.0%	10.0%	10.0%	10.0%	10.0%	10.0%	10.0%	10.0%	10.0%	10.0%	10.0%	10.0%	10.0%	10.0%	10.0%	10.0%	10.0%	10.0%	10.0%	10.0%	10.0%	10.0%	10.0%	10.0%
15	3.3%	6.7%	6.7%	6.7%	6.7%	6.7%	6.7%	6.7%	6.7%	6.7%	6.7%	6.7%	6.7%	6.7%	6.7%	6.7%	6.7%	6.7%	6.7%	6.7%	6.7%	6.7%	6.7%	6.7%	6.7%	6.7%	6.7%
20	2.5%	5.0%	5.0%	5.0%	5.0%	5.0%	5.0%	5.0%	5.0%	5.0%	5.0%	5.0%	5.0%	5.0%	5.0%	5.0%	5.0%	5.0%	5.0%	5.0%	5.0%	5.0%	5.0%	5.0%	5.0%	5.0%	5.0%
25	2.0%	4.0%	4.0%	4.0%	4.0%	4.0%	4.0%	4.0%	4.0%	4.0%	4.0%	4.0%	4.0%	4.0%	4.0%	4.0%	4.0%	4.0%	4.0%	4.0%	4.0%	4.0%	4.0%	4.0%	4.0%	4.0%	4.0%
28	1.8%	3.6%	3.6%	3.6%	3.6%	3.6%	3.6%	3.6%	3.6%	3.6%	3.6%	3.6%	3.6%	3.6%	3.6%	3.6%	3.6%	3.6%	3.6%	3.6%	3.6%	3.6%	3.6%	3.6%	3.6%	3.6%	3.6%
30	1.7%	3.3%	3.3%	3.3%	3.3%	3.3%	3.3%	3.3%	3.3%	3.3%	3.3%	3.3%	3.3%	3.3%	3.3%	3.3%	3.3%	3.3%	3.3%	3.3%	3.3%	3.3%	3.3%	3.3%	3.3%	3.3%	3.3%
35	1.4%	2.9%	2.9%	2.9%	2.9%	2.9%	2.9%	2.9%	2.9%	2.9%	2.9%	2.9%	2.9%	2.9%	2.9%	2.9%	2.9%	2.9%	2.9%	2.9%	2.9%	2.9%	2.9%	2.9%	2.9%	2.9%	2.9%
50	1.0%	2.0%	2.0%	2.0%	2.0%	2.0%	2.0%	2.0%	2.0%	2.0%	2.0%	2.0%	2.0%	2.0%	2.0%	2.0%	2.0%	2.0%	2.0%	2.0%	2.0%	2.0%	2.0%	2.0%	2.0%	2.0%	2.0%
Source: IRS Publication 946, Table A-8																											
Tax Depreciation Rates (MACRS)																											
-																											
3	33.3%	44.5%	14.8%	7.4%																							
5	20.0%	32.0%	19.2%	11.5%	11.5%	5.8%																					
7	14.3%	24.5%	17.5%	12.5%	8.9%	8.9%	4.5%																				
10	10.0%	18.0%	14.4%	11.5%	9.2%	7.4%	6.6%	6.6%	6.6%	6.6%	6.6%	6.6%	6.6%	6.6%	6.6%	6.6%	6.6%	6.6%	6.6%	6.6%	6.6%	6.6%	6.6%	6.6%	6.6%	6.6%	6.6%
15	5.0%	9.5%	8.6%	7.7%	6.9%	6.2%	5.9%	5.9%	5.9%	5.9%	5.9%	5.9%	5.9%	5.9%	5.9%	5.9%	5.9%	5.9%	5.9%	5.9%	5.9%	5.9%	5.9%	5.9%	5.9%	5.9%	5.9%
20	3.8%	7.2%	6.7%	6.2%	5.7%	5.3%	4.9%	4.5%	4.5%	4.5%	4.5%	4.5%	4.5%	4.5%	4.5%	4.5%	4.5%	4.5%	4.5%	4.5%	4.5%	4.5%	4.5%	4.5%	4.5%	4.5%	4.5%
Source: IRS Publication 946, Table A-1																											

Tax Depreciation

Project Name	Tax Depreciation Factors							
	Years	55	56	57	58	59	60	Total
	Manual Input							
	Tax Depreciation Rate							
	-							
	3							100.0000%
	5							100.0000%
	7							100.0000%
	10							100.0000%
	15							100.0000%
	20							100.0000%
	25							100.0000%
	28							100.0000%
	30							100.0000%
	35							100.0000%
	50							100.0000%
Source: IRS Publication 946, T:								
	Tax Depreciation Rate							
	-							
	3							100.0000%
	5							100.0000%
	7							100.0000%
	10							100.0000%
	15							100.0000%
	20							100.0000%
Source: IRS Publication 946, T:								

Project Name	1	2	3	4	5	6	7	8	9	10
Revenue Requirements Model - Calculations										
Manual input										
O&M										
Escalation Rate	1.00	1.02	1.04	1.06	1.08	1.10	1.13	1.15	1.17	1.20
O&M	-	-	-	-	-	-	-	-	-	-
Plant Asset Depreciation										
Book Depreciation										
Book Depreciation Rates	0.000%	5.263%	5.263%	5.263%	5.263%	5.263%	5.263%	5.263%	5.263%	5.263%
Depreciation Expense	-	53	53	53	53	53	53	53	53	53
Accumulated Depreciation	-	53	105	158	211	263	316	368	421	474
Tax Depreciation										
Tax Depreciation Rates (Straight Line)	20	2.500%	5.000%	5.000%	5.000%	5.000%	5.000%	5.000%	5.000%	5.000%
Tax Basis (SL)	0.0%									
Tax Depreciation Rates (MACRS)	15	5.000%	8.550%	7.700%	6.930%	6.230%	5.900%	5.900%	5.910%	5.900%
NonRB Financed Tax Basis (MACRS)	100.0%	50	95	86	77	69	62	59	59	59
Tax Depreciation		50	95	86	77	69	62	59	59	59
Accumulated Tax Depreciation		50	145	231	308	377	439	498	557	616
State Investment Tax Credit (ITC)										
Book										
State ITC Amortization Rate	0.000%	10.000%	10.000%	10.000%	10.000%	10.000%	10.000%	10.000%	10.000%	10.000%
Amortization of State ITC	4.00%	-	4	4	4	4	4	4	4	4
Accumulated Amortization		-	4	8	12	16	20	24	28	32
Deferred ITC		40	36	32	28	24	20	16	12	8
Tax		40								
Deferred Tax Calculation										
Book Accumulated Depreciation	-	53	105	158	211	263	316	368	421	474
Tax Accumulated Depreciation	50	145	231	308	377	439	498	557	616	675
Book/Tax Acc Depr Difference	(50)	(92)	(125)	(150)	(166)	(176)	(182)	(189)	(195)	(202)
Deferred ITC	40	36	32	28	24	20	16	12	8	4
Net Deferred Tax Asset (Liability)	(3)	(15)	(24)	(31)	(37)	(40)	(43)	(45)	(48)	(51)
Deferred Tax Base	10	46	37	28	21	14	10	10	10	10
Deferred Taxes - Federal	2	9	7	6	4	3	2	2	2	2

Revenue Requirements Model - Calculations												
Manual input	1	2	3	4	5	6	7	8	9	10		
Total State Tax	2	4	4	4	3	3	3	3	2	2		
Total Federal Tax	7	13	13	12	11	10	9	9	8	7		
Total ITC	-	(4)	(4)	(4)	(4)	(4)	(4)	(4)	(4)	(4)		
TOTAL Incurred Tax Expense (Benefit)	9	14	12	11	10	9	8	7	6	5		
	-	-	-	-	-	-	-	-	-	-		

check

REQUEST FOR PROPOSALS
FOR
VARIABLE RENEWABLE DISPATCHABLE GENERATION
AND
ENERGY STORAGE
ISLAND OF HAWAI‘I

AUGUST 22, 2019

Docket No. 2017-0352

*Appendix H – Interconnection Facilities and Cost
Information*



**Hawai‘i
Electric
Light**

Hawaii Electric Light Company
 APPENDIX H- INTERCONNECTION FACILITIES AND COST INFORMATION 2019

Tariff Rule No. 19, approved by the PUC, establishes provisions for Interconnection and Transmission Upgrades (see Appendix I). The tariff provisions are intended to simplify the rules regarding who pays for, installs, owns, and operates interconnection facilities in the context of competitive bidding. Tariff Rule No. 19 will be utilized as the basis for addressing interconnection and transmission upgrades for any projects developed through this RFP. Bidders will comply with the terms and conditions as specified therein.

To assist Bidders in assessing the impacts of location on potential projects, the per unit cost figures provided in the tables below are to be used to provide an approximate estimated cost for interconnecting, including substation, communications, security, and transmission or distribution line cost to the existing Hawaii Electric Light System. The per unit cost figures below should not be used to create a detailed project estimate. A detailed project estimate typically requires a certain level of engineering to assess project site conditions and to factor in other parameters specific to the project.

The Bidder should identify the components assumed for their project and the quantity assumed for each. Each table below provides notes on the assumptions for each of the unit cost estimates. If a Bidder's project requirements are different than what is assumed in the notes, the Bidder should identify each difference and provide an estimated additional cost or savings resulting from those different requirements.

2.1 Transmission & Distribution Line Interconnection Costs

Component	Description	Cost per Mile
1	New 69kV Overhead line (accessible 500' spans)	\$900,000
2	69kV overbuild with existing 12kV (accessible 500' spans)	\$1,130,000

Notes:

1. New 69kV Overhead line (accessible) consists of 70' height H-4 wood poles (61' above / 9' below grade).
2. 69kV Overbuilt line (accessible) consists of 75' height H-4 wood poles with 12kV distribution and HTCOM facilities attached.
3. Note: Exclusions to these rough costs are as follows but not limited to:
 - a. Development of the PUC application/proceedings timeline
 - b. State or County right-of-way permitting and SMA
 - c. Environmental studies cost

Hawaii Electric Light Company

APPENDIX H- INTERCONNECTION FACILITIES AND COST INFORMATION 2019

- d. Survey proposed line extension route
 - e. Easement/Land Issues if discovered in the course of final design
 - f. Archaeological survey and monitoring cost/duration (if needed)
 - g. Clearing/grading along power line corridor and access road
 - h. Final design adjustments required to negotiate terrain, physical landmarks, existing utilities and access
 - i. Straight line path for optimal pole placement with minimal anchors.
 - j. Construction of permanent roadways/truck access
 - k. Helicopter services
 - l. Traffic Control
 - m. Removals (MECO & HTCOCOM as applicable)
 - n. Salvage and depreciation credits
 - o. Street lights
 - p. Delays due to weather and material acquisitions
4. All estimates are provided in 2022 dollars.

Hawaii Electric Light Company
 APPENDIX H- INTERCONNECTION FACILITIES AND COST INFORMATION 2019

2.2 Substation Interconnection Costs

2.2.1 Substation 69kV Interconnection Costs FIRM and VARIABLE Projects

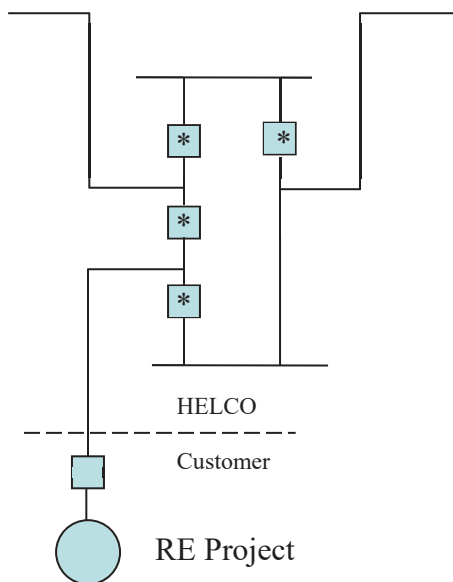

Component	Description	Cost
1	*4 – 69kV circuit breakers in breaker-and-half configuration (HELCO)	\$5,000,000

Notes:

1. Substation land that is received has been graded per Hawaii Electric Light’s civil and structural requirements. No costs for excavation and fill are included in the estimates.
2. Permits are not included in indicated costs.
3. Costs are in 2022 dollars.
4. Estimate does not contain any of the following costs:
 - a. Telecommunication infrastructure
 - b. Relay Coordination Study
 - c. Project Management
 - d. Any required upgrades to existing substations to integrate the new generating facility into the system.
5. Substation relay protection requirements have not been identified, so costs are based upon typical line protection relaying requirements.
6. Control house and local SCADA equipment are included in cost estimates.

Hawaii Electric Light Company
 APPENDIX H- INTERCONNECTION FACILITIES AND COST INFORMATION 2019

7. Projects shall be designed to limit the maximum loss-of-generation contingency to 30MW due to system reliability requirements. This may include splitting the project capacity and installing additional breaker(s) in the ring bus on network circuits.

2.2.2 Substation 13.8kV Interconnection Costs for BESS at Puna Site only

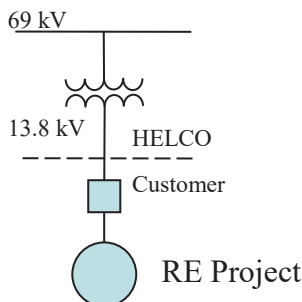

Component	Description	Cost
N/A	Tie to existing transformer at 13.8kV (Refer to table in 2.1 for per unit line extension cost.)	\$800,000

Notes:

1. No costs for excavation and fill are included in the estimates.
2. Permits are not included in indicated costs.
3. Costs are in 2022 dollars.
4. Estimate does not contain any of the following costs:
 - a. Telecommunication infrastructure
 - b. Relay Coordination Study
 - c. Project Management
 - d. Line extension
5. Substation relay protection requirements have not been identified, so costs are based upon typical circuit breaker relaying requirements.
6. This interconnection option is a special exception for contingency energy storage at Puna Switching station only due to existing capacity, as well as diversity of use of the transformer.

2.3 Telecommunications

1. Point-to-point microwave: \$1,150,000 with the following assumptions:
 - a. There is line-of-sight between the communications endpoints.

Hawaii Electric Light Company
APPENDIX H- INTERCONNECTION FACILITIES AND COST INFORMATION 2019

- b. Frequencies are available.
 - c. There are existing structures/buildings and available space on either end to house the radio equipment.
 - d. Telecommunications grounding standards are up-to-date at both sites.
 - e. -48V DC power is available.
 - f. This estimate does not include any special permit/approval that is required site-specific.
 - g. Space is available to locate antenna towers/structures at both ends.
 - h. Interconnection to Hawaii Electric Light's existing communications is not included.
2. Fiber with overbuild and new construction: \$225,000 per mile with the following assumptions:
- a. The poles are in good condition and do not need replacing.
 - b. The poles are not overloaded.
 - c. The poles and the attachments are in accordance with NESC 2002 and no work is required to upgrade the poles to current standards.

2.4 Security System Interconnection Costs

2.4.1 Proposals for interconnection via a new 69 kV substation

1. Equipment/Electronics for security \$265,000 with the following assumptions:
 - a. Civil facilities associated with security (e.g., site fencing, conduits for security systems) for the new 69 kV substation, costs are included under Item 2.2.1 above.
 - b. Systems incorporated will be equivalent to the Tier 1 requirements identified in the table below for Company facilities.
 - c. Costs are in 2022 dollars.

2.4.2 The customer shall be responsible to incorporate security components and systems for **their facilities** that consider the Security Guidelines for the Electricity Sector: Physical Security as published by the North American Electric Reliability Corporation (NERC), available at the link noted below, and that at a minimum adhere to Company's performance requirements, outlined in Company's Physical Security Strategy (as provided by Company), for the following four security concepts.

Hawaii Electric Light Company
 APPENDIX H- INTERCONNECTION FACILITIES AND COST INFORMATION 2019

<https://www.nerc.com/docs/cip/sgwg/Physical%20Security%20Guideline%202011-10-21%20Formatted.pdf>

- **Deter:** Deploy visible physical security measures to encourage individuals to seek other, less secure targets.
- **Detect:** Utilize state of the art physical security technologies to detect unauthorized intrusion and provide real-time alerts to monitoring personnel. Detection to include 24/7 monitoring personnel.
- **Delay:** Deploy multiple physical security countermeasures to delay an intruder’s access to assets, and provide time for incident assessment and appropriate response. (See: Defense in Depth)
- **Respond:** Take immediate measures to assess, interrupt, and/or respond to the incident, including notification to Company and the use of contracted patrol personnel and/or the involvement of law enforcement assets to apprehend an intruder.

Type of Facility	Tier One High Criticality	Tier Two Medium Criticality	Tier Three Lower Criticality
Substation	<ul style="list-style-type: none"> • FLIR camera perimeter monitoring. • Secondary perimeter intrusion detection system. • Interior Video monitoring system with motion detection. • Gunfire detection/IP intercom public address system. • Electronic card access system for control & microwave houses. • Standard 8’ high security fence with 3-strand barbed wire V-top. • Interior mounted 4’ high cattle fencing. • LED perimeter lighting. • All gates will be secured using a proprietary padlock system. 	<ul style="list-style-type: none"> • Video monitoring system with motion detection. • Card access on control and microwave houses. • Standard 8’ high security fence with 3-strand barbed wire V-top. • Interior mounted 4’ high cattle fencing. • All gates will be secured using a proprietary padlock system. 	<ul style="list-style-type: none"> • Standard 8’ high security fence with 3-strand barbed wire V-top. • Interior mounted 4’ high cattle fencing. • All gates will be secured using a proprietary padlock system.

REQUEST FOR PROPOSALS
FOR
VARIABLE RENEWABLE DISPATCHABLE GENERATION
AND
ENERGY STORAGE
ISLAND OF HAWAI‘I

AUGUST 22, 2019

Docket No. 2017-0352

Appendix I – Rule 19 Tariff



**Hawai‘i
Electric
Light**

RULE NO. 19

Interconnection and Transmission Upgrades

A. GENERAL

1. Definitions

- a. "Betterment" means and includes any upgrading to a facility made solely for the benefit of and at the election of the Company, not attributable to the interconnection requirements. The Betterment includes any provisions for future expansion which cannot be charged to replacement. It also includes any related system work beyond that required for interconnection. If an existing facility is replaced with one of greater functional capacity or capability, the difference between the upgraded facility and a replacement facility of equivalent functional capacity is considered Betterment. It does not mean the substitution of a replacement facility for an existing facility, that is, an underground facility for an overhead facility, unless otherwise provided for in the RFP.

Example 1: A substation with a three breaker scheme is required to connect the Generating Facility to the grid. If the Company installs a substation with a six breaker ring bus scheme, the difference between installing a substation with a three breaker scheme and one with a six breaker scheme would be the Betterment.

Example 2: A transmission line needs to be upgraded to accommodate a new Generating Facility. The existing line is designed to withstand a 56 mph wind speed. The project includes upgrading the facilities to withstand a 100 mph wind speed. The increase in the design to the 100 mph wind speed criteria would be the Betterment.

Example 3: A transmission line needs to be upgraded to accommodate a new Generating Facility. In response to the Company's application to upgrade the line, the Commission orders that the line be placed underground. The cost difference between the overhead upgrade and the installation of the underground facilities would not be considered Betterment.

- b. "Company's Dispatch" means the Company's sole and absolute right to control, from moment to moment, through Supervisory Control, or otherwise, and in accordance with good engineering and operating practices in the electric utility industry, the rate of delivery of energy offered by the bidder to the Company.
- c. "Company's System" means the electric system owned and operated by the Company (to include any non-utility owned facilities) consisting of power plants, transmission and distribution lines, and related equipment for the production and delivery of electric power to the public.

HAWAII ELECTRIC LIGHT COMPANY, INC.

RULE NO. 19 - Continued

Interconnection and Transmission Upgrades

Example 2: A proposed Generating Facility is remotely located in a region of the island where there are no existing Transmission System facilities. In this case, if the size of the Generating Facility requires that it be tied to the existing Transmission System, the new Transmission System facilities (i.e. all electrical wires, equipment, and other facilities at the transmission voltage level) constructed from the Generating Facility to the Company's existing Transmission System facilities would be considered Interconnection Facilities.

- j. "Interconnection Requirements Study (IRS)" means a study, performed in accordance with the terms of the IRS Letter Agreement and with the applicable terms of the RFP and any resulting PPA, to identify the Interconnection Facilities, System Upgrades and other system requirements and all associated costs to integrate the proposed Generating Facility with the Company's System, and includes a detailed steady-state and a dynamic analysis. The IRS is conducted by the Company or its consultant and the bidder is responsible for the cost of conducting the IRS.
- k. "Interconnection Requirements Study Letter Agreement (IRS Letter Agreement)" means the letter agreement and any written, signed amendments thereto, between the Company and the bidder that describes the scope, schedule, and payment arrangements for the IRS.
- l. "IRP" means an electric utility's Integrated Resource Plan that has been submitted to the Commission for review and approval in the utility's IRP proceeding, in accordance with the Commission's IRP Framework.
- m. "IRP Framework" means the Commission's Framework for Integrated Resource Planning, dated May 22, 1992, as amended by In re Public Util. Comm'n, Docket No. 05-0075, Decision and Order No. 22490, filed on May 26, 2006.
- n. "Point of Interconnection" means the point of delivery of Energy and/or Capacity supplied by the bidder to the Company, where the facilities owned by the bidder interconnect with the facilities owned or to be owned by the Company. The bidder shall own and maintain the facilities from the Generating Facility to the Point of Interconnection. The Company shall own and maintain the facilities from the Point of Interconnection to the Company's System (see examples given in Attachment A). The Point of Interconnection will be identified in the IRS.
- o. "PPA" means a power purchase agreement or contract by the Company to purchase firm capacity, energy, or both.

HAWAII ELECTRIC LIGHT COMPANY, INC.

RULE NO. 19 - Continued

Interconnection and Transmission Upgrades

v. "Transmission System" means all electrical wires, equipment, and other facilities at the transmission voltage levels (such as 138kV or 69kV) owned or provided by the utility, through which the utility provides electrical service to its customers.

2. Application of Tariff

This Tariff shall apply to an RFP issued pursuant to the Framework and Interconnection Requirement Studies arising from the RFP process. In the event that there is a conflict between any provision of this Tariff and that of an RFP issued pursuant to the Framework and reviewed by the Commission in accordance with Sections III.B.2 and IV.B.6.e. of the Framework, the provisions of the RFP shall prevail. The terms and conditions established in a PPA arising from the RFP and approved by the Commission shall ultimately control over the requirements and terms of both this Tariff and the RFP.

3. Independent Observer

As established in the Framework, the duties and responsibilities of an Independent Observer (IO) include, among other duties and responsibilities, reviewing and monitoring the Company's communications, methods, and implementation of this Tariff, the RFP and related IRS processes.

B. INTERCONNECTION STUDY PROCESS FOR COMPETITIVE BIDDING

1. RFP Package Data -- available to all prospective bidders.

RFP packages issued by the Company shall contain general and regional system information to provide prospective bidders with high level guidance relating to the Company's existing transmission infrastructure. For example, RFP packages may include information in the form of an island map with areas of the Transmission System identified that are at or near their loading limits to provide high level guidance to bidders on areas of the island with transmission constraints. These constraints may include "load pockets", which are load-driven transmission constraints as well as areas of generation-driven transmission constraints. Because transmission impacts are to a large extent specific to the characteristics of supply-side proposals, definitive transmission information cannot be provided in these maps. Detailed geographic maps of the transmission system may not be part of this information due to security concerns. Rather, a map of the island with areas of the map shaded to identify areas (rather than circuits) of transmission constraints, may be provided.

HAWAII ELECTRIC LIGHT COMPANY, INC.

RULE NO. 19 - Continued

Interconnection and Transmission Upgrades

- b. For each bid, a high level estimate of the costs of Interconnection Facilities and required System Upgrades will be developed based solely on the high level evaluation identified in Section B.4.a. of this Tariff and on unitized cost estimates (e.g., \$/mile for 138kV line, \$/transformer).
 - c. Results of the high level evaluation and high level estimate of the costs of Interconnection Facilities and required System Upgrades will be factored into the determination of which bids make the short list based on the requirements specified in the RFP.
 - d. Basic curtailment analysis of the proposed Generating Facility and related impacts to operations of existing Generating Facilities may also be factored into the determination of which bids make the short list based on the requirements specified in the RFP.
5. Full Interconnection Requirements Study - performed only on short list bids.
- a. An IRS shall be performed only for bid(s) that have met the RFP requirements, passed the threshold criteria, and made the short list, or as otherwise specified in the RFP.
 - b. An IRS would be performed either serially starting with the bid evaluated as the most competitive at the point of the evaluation process, then proceeding to the next most competitive bid on the short list or in parallel on all or some of the short list bidders simultaneously. The determination of whether or not IRS work is to be performed serially, in parallel, or a combination of the two will be based upon factors such as resource availability, number of short list bids, RFP schedule, and relative competitiveness of one bid to others, and the availability of all information and data from bidders necessary to perform the IRS work
 - c. The Company may if practicable "bundle" IRS work for multiple short list bids into a single IRS if the bids are, among other factors, technically, operationally and geographically (e.g., size, location, technology, timing, operating characteristics, etc.) identical or sufficiently similar to each other.
 - d. The results of the IRS, including identified Interconnection Facilities, System Upgrades, Point of Interconnection, and Grid Connection Point, will be provided to the bidder.
 - e. Bidders shall be responsible for incorporating the costs of their Interconnection Facilities into their bids. The RFP may provide bidders with an opportunity to revise their pricing proposals under certain circumstances. Any pricing change, if permitted under the terms of the RFP, will prompt a re-evaluation of short list bidders in the selection of the winning bid as provided for in the RFP.

HAWAII ELECTRIC LIGHT COMPANY, INC.

RULE NO. 19 - Continued

Interconnection and Transmission Upgrades

4. The Company shall install and maintain the identified System Upgrades arising from the interconnection of the Generating Facility and shall be responsible for the cost of such System Upgrades.
 - a. The Company's cost for System Upgrades will be considered as a factor in the bid evaluations.
 - b. The degree to which the System Upgrades provide System Benefits and/or Betterments will be considered in the bid evaluations.
5. Standards and Interconnection Agreements
 - a. Interconnection Facilities and System Upgrades owned or to be owned by the Company shall be constructed in accordance with the Company's applicable standards and in accordance with the PPA or the Interconnection Agreement, if there is a separate Interconnection Agreement.
 - b. Generating Facilities and Interconnection Facilities owned by the bidder shall be constructed in accordance with applicable State and County code requirements and in accordance with the PPA or the Interconnection Agreement, if there is a separate Interconnection Agreement.
 - c. The bidder's Generating Facility may be interconnected and operated in parallel with the Company's System in accordance with the terms and conditions of the PPA between the Company and the bidder, and/or the terms and conditions of an Interconnection Agreement between the Company and the bidder, if there is a separate Interconnection Agreement.
 - d. The bidder will be required to furnish, install, operate, and maintain suitable and sufficient equipment, to maintain adequate records, and to follow such operating procedures, as may be specified by the Company to protect the Company's System from damage resulting from the parallel operation of the Seller's Facility, including the equipment, records and operating procedures more fully described in the PPA and/or Interconnection Agreement, if there is a separate Interconnection Agreement.
 - e. Interconnection Facilities shall be designed, installed operated and maintained in accordance with good interconnection practice. The objectives of good interconnection practice include, but are not limited to,
 1. Safety - To protect the safety of utility personnel, utility customers, and the public.

HAWAII ELECTRIC LIGHT COMPANY, INC.

RULE NO. 19 - Continued

Interconnection and Transmission Upgrades

Attachment A

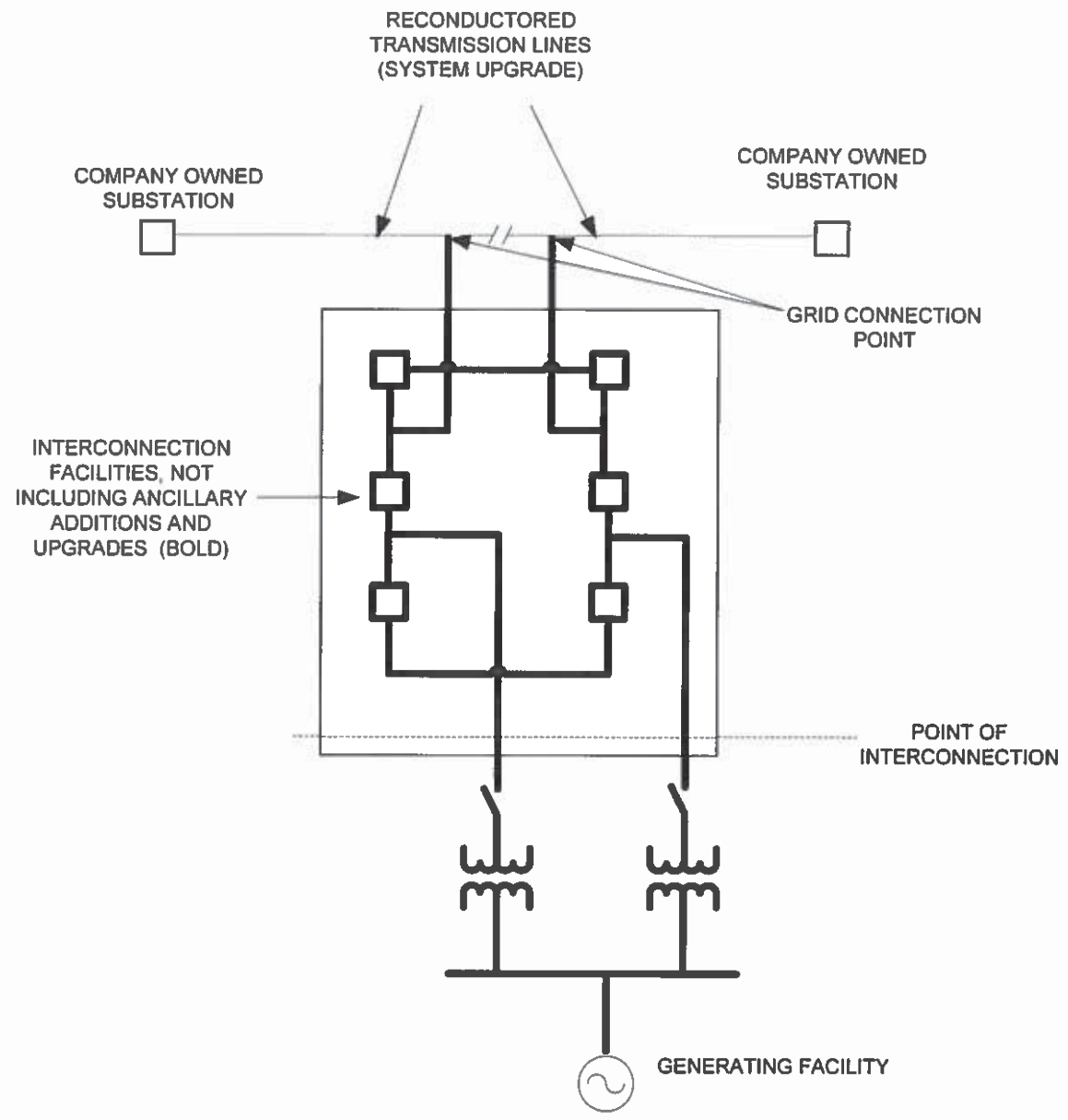

HAWAII ELECTRIC LIGHT COMPANY, INC.

Docket No. 03-0372, D&O No. 23799, Dated November 5, 2007
Transmittal Letter Dated November 9, 2007



Model

*Power Purchase Agreement
For
Renewable Dispatchable Generation
(PV + BESS)*

August 22, 2019 Version

This document indicates, for information purposes only, the terms and conditions that may be negotiated in a contract for the sale of renewable dispatchable generation to be executed by Hawai'i Electric Light Company, Inc. The terms and conditions that may be offered by Hawai'i Electric Light Company, Inc. in a renewable dispatchable generation power purchase agreement may be modified to reflect factors such as different renewable technologies, project specifics, changes in applicable rules, guidance from the Public Utilities Commission in proceedings concerning the approval or negotiation of such power purchase agreements, results of an interconnection requirements study and other negotiated terms and conditions. This document also assumes that the proposed generation facility will be paired with a battery energy storage system ("BESS"), and therefore, contains terms and conditions with respect to the BESS. If a generation only proposal is selected for the RFP's final award group, the BESS specific provisions will be removed for the power purchase agreement for such project proposal.

[NOTE: TEXT WITHIN THIS DOCUMENT THAT APPEARS IN BOLD AND/OR BRACKETS INDICATES A PROVISION THAT MAY REQUIRE REVISION TO CONFORM TO A SPECIFIC PROJECT.]

TABLE OF CONTENTS

ARTICLE 1 PARALLEL OPERATION 3

ARTICLE 2 PURCHASE AND SALE OF ENERGY AND DISPATCHABILITY; RATE
FOR PURCHASE AND SALE; BILLING AND PAYMENT 4

ARTICLE 3 FACILITY OWNED AND/OR OPERATED BY SELLER 44

ARTICLE 4 COMPANY-OWNED INTERCONNECTION FACILITIES 50

ARTICLE 5 MAINTENANCE RECORDS AND SCHEDULING 51

ARTICLE 6 FORECASTING 56

ARTICLE 7 SELLER PAYMENTS 60

ARTICLE 8 COMPANY DISPATCH 61

ARTICLE 9 PERSONNEL AND SYSTEM SAFETY 63

ARTICLE 10 METERING 64

ARTICLE 11 GOVERNMENTAL APPROVALS, LAND RIGHTS AND COMPLIANCE WITH
LAWS 66

ARTICLE 12 TERM OF AGREEMENT AND COMPANY'S OPTION TO PURCHASE AT
END OF TERM 69

ARTICLE 13 GUARANTEED PROJECT MILESTONES INCLUDING COMMERCIAL
OPERATIONS 75

ARTICLE 14 CREDIT ASSURANCE AND SECURITY 81

ARTICLE 15 EVENTS OF DEFAULT 86

ARTICLE 16 DAMAGES IN THE EVENT OF TERMINATION BY COMPANY 92

ARTICLE 17 INDEMNIFICATION 94

ARTICLE 18 INSURANCE 99

ARTICLE 19 TRANSFERS, ASSIGNMENTS, AND FACILITY DEBT 102

ARTICLE 20 SALE OF ENERGY TO THIRD PARTIES 105

ARTICLE 21 FORCE MAJEURE 106

ARTICLE 22 WARRANTIES AND REPRESENTATIONS 111

ARTICLE 23 PROCESS FOR ADDRESSING REVISIONS TO PERFORMANCE
STANDARDS 113

ARTICLE 24 FINANCIAL COMPLIANCE 119

ARTICLE 25 GOOD ENGINEERING AND OPERATING PRACTICES 123

ARTICLE 26 EQUAL EMPLOYMENT OPPORTUNITY 124

ARTICLE 27 SET OFF 125

ARTICLE 28 DISPUTE RESOLUTION 126

ARTICLE 29 MISCELLANEOUS 128

SCHEDULE OF DEFINED TERMS SCHEDULE OF DEFINED TERMS-1

ATTACHMENT A DESCRIPTION OF GENERATION, CONVERSION AND STORAGE
FACILITY A-1

EXHIBIT A-1 GOOD STANDING CERTIFICATES A-1

EXHIBIT A-2 OWNERSHIP STRUCTURE A-2

ATTACHMENT B FACILITY OWNED BY SELLER B-1

EXHIBIT B-1 MODELING REQUIREMENTS .. B-**ERROR! BOOKMARK NOT DEFINED.**

EXHIBIT B-2 GENERATOR AND ENERGY STORAGE CAPABILITY CURVE(S) ... B-
ERROR! BOOKMARK NOT DEFINED.

ATTACHMENT C METHODS AND FORMULAS FOR MEASURING PERFORMANCE
STANDARDS C-**ERROR! BOOKMARK NOT DEFINED.**

ATTACHMENT D CONSULTANTS LIST D-1
ATTACHMENT E SINGLE-LINE DRAWING AND INTERFACE BLOCK DIAGRAM .. E-1
ATTACHMENT F RELAY LIST AND TRIP SCHEME F-1
ATTACHMENT G COMPANY-OWNED INTERCONNECTION FACILITIES G-1
ATTACHMENT H FORM OF BILL OF SALE AND ASSIGNMENT H-2
SCHEDULE H-1 DESCRIPTION OF TANGIBLE PERSONAL PROPERTY AND
FIXTURES H-5
SCHEDULE H-2 DESCRIPTION OF INTANGIBLE PERSONAL PROPERTY H-6
ATTACHMENT I FORM OF ASSIGNMENT OF LEASE AND ASSUMPTION I-1
SCHEDULE 1 I-7
ATTACHMENT J COMPANY PAYMENTS FOR ENERGY, DISPATCHABILITY AND
AVAILABILITY OF BESS J-1
ATTACHMENT K GUARANTEED PROJECT MILESTONES [**FOR DEVELOPER
INTERCONNECTION BUILD**] K-1
ATTACHMENT K-1 SELLER'S CONDITIONS PRECEDENT AND COMPANY
MILESTONES [**FOR DEVELOPER INTERCONNECTION BUILD**] K-2

ATTACHMENT L REPORTING MILESTONES [**FOR DEVELOPER INTERCONNECTION
BUILD**] L-1
ATTACHMENT M FORM OF LETTER OF CREDIT M-1
ATTACHMENT N ACCEPTANCE TEST GENERAL CRITERIA N-1
ATTACHMENT O CONTROL SYSTEM ACCEPTANCE TEST CRITERIA O-1
ATTACHMENT P SALE OF FACILITY BY SELLER P-1
ATTACHMENT Q RESERVED Q-1
ATTACHMENT R REQUIRED INSURANCE R-1
ATTACHMENT S FORM OF MONTHLY PROGRESS REPORT S-1
ATTACHMENT T MONTHLY REPORTING AND DISPUTE RESOLUTION BY
INDEPENDENT AF EVALUATOR T-1
ATTACHMENT U CALCULATION AND ADJUSTMENT OF NET ENERGY POTENTIAL U-1
ATTACHMENT V SUMMARY OF MAINTENANCE AND INSPECTION PERFORMED IN
PRIOR CALENDAR YEAR V-1
ATTACHMENT W BESS TESTS W-1
ATTACHMENT X BESS ANNUAL EQUIVALENT AVAILABILITY FACTOR X-1
ATTACHMENT Y BESS ANNUAL EQUIVALENT FORCED OUTAGE FACTOR Y-1

POWER PURCHASE AGREEMENT FOR RENEWABLE DISPATCHABLE GENERATION

THIS POWER PURCHASE AGREEMENT FOR RENEWABLE DISPATCHABLE GENERATION ("Agreement") is made this ____ day of _____, 20__ (the "Execution Date"), by and between Hawai'i Electric Light Company, Inc., a Hawai'i corporation (hereinafter called the "Company") and _____ (hereinafter called the "Seller").

WHEREAS, Company is an operating electric public utility on the Island of Hawai'i, subject to the Hawai'i Public Utilities Law (Hawai'i Revised Statutes, Chapter 269) and the rules and regulations of the Hawai'i Public Utilities Commission (hereinafter called the "PUC"); and

WHEREAS, the Company System is operated as an independent power grid and must both maximize system reliability for its customers by ensuring that sufficient generation is available and meet the requirements for voltage stability, frequency stability, and reliability standards; and

WHEREAS, Company desires to minimize fluctuations in its purchased energy costs by acquiring renewable dispatchable generation at a fixed Unit Price; and

WHEREAS, Seller desires to build, own, and operate a renewable energy facility that is classified as an eligible resource under Hawai'i's Renewable Portfolio Standards Statute (codified as Hawai'i Revised Statutes ("HRS") 269-91 through 269-95); and

WHEREAS, Seller understands the need to use all commercially reasonable efforts to maximize the overall reliability of the Company System; and

WHEREAS, Facility will be located at _____, State of Hawai'i and is more fully described in Attachment A (Description of Generation, Conversion and Storage Facility) and Attachment B (Facility Owned by Seller) attached hereto and made a part hereof; and

WHEREAS, Seller desires to sell to Company, and Company agrees to purchase upon the terms and conditions set forth herein, (i) the Actual Output produced by the Facility and delivered to the Point of Interconnection; (ii) the availability of the BESS;

and (iii) the availability of the Facility's Net Energy Potential for Company Dispatch in accordance with this Agreement.

NOW, THEREFORE, in consideration of the premises and the respective promises herein, Company and Seller hereby agree as follows:

DEFINITIONS

When the capitalized terms set forth in the Schedule of Defined Terms are used in this Agreement, such terms shall have the meanings set forth in such Schedule.

ARTICLE 1
PARALLEL OPERATION

Company agrees to allow Seller to interconnect and operate the Facility to provide renewable dispatchable generation and energy in parallel with the Company System; provided, however, that such interconnection and operation shall not: (i) adversely affect Company's property or the operations of its customers and customers' property; (ii) present safety hazards to the Company System, Company's property or employees or Company's customers or the customers' property or employees; or (iii) otherwise fail to comply with this Agreement. Such parallel operation shall be contingent upon the satisfactory completion, as determined solely by Company, of the Acceptance Test and, to the extent applicable, the Control System Acceptance Test, in accordance with Good Engineering and Operating Practices.

ARTICLE 2
PURCHASE AND SALE OF ENERGY AND DISPATCHABILITY;
RATE FOR PURCHASE AND SALE; BILLING AND PAYMENT

- 2.1 Purchase and Sale of Electric Energy, Dispatchability of Facility and Availability of the BESS. Subject to the other provisions of this Agreement, Company shall, by a Lump Sum Payment, pay for: (i) the Actual Output produced by the Facility and delivered to the Point of Interconnection in response to Company Dispatch of the Facility; (ii) the availability of the Facility's Net Energy Potential for Company Dispatch in accordance with this Agreement; and (iii) the availability of the BESS. Included in such purchase and sale are all of the Environmental Credits associated with the electric energy. Company will not reimburse Seller for any taxes or fees imposed on Seller including, but not limited to, State of Hawai'i general excise tax. **[Drafting Note: For PPA with energy payment, use the following in lieu of the above:** Subject to the other provisions of this Agreement: (i) Company shall, by an Energy Payment, pay for the Actual Output produced by the Facility and delivered to the Point of Interconnection in response to Company Dispatch of the Facility; and (ii) Company shall, by a Lump Sum Payment, pay for the availability of the Facility's Net Energy Potential and the availability of the BESS to respond to Company Dispatch in accordance with this Agreement. Included in such purchase and sale of electric energy and such purchase and sale of dispatchability are all of the Environmental Credits associated with the electric energy. Company will not reimburse Seller for any taxes or fees imposed on Seller including, but not limited to, State of Hawai'i general excise tax.]
- 2.2 **[Drafting Note: If there is no Energy Payment, replace this paragraph with [RESERVED]]** Payment for Electric Energy. Commencing on the Commercial Operations Date, in exchange for the electric energy delivered to the Point of Interconnection in response to Company Dispatch, Seller will be paid an Energy Payment on a monthly basis as provided in Section 1 (Price for Purchase of Electric Energy) of Attachment J (Company Payments for Energy, Dispatchability and Availability of BESS) to this Agreement.
- 2.3 Lump Sum Payment. Commencing on the Commercial Operations Date, Company shall pay to Seller a monthly Lump Sum Payment

as provided in Section 2 (Lump Sum Payment for Purchase of Dispatchability) of Attachment J (Company Payments for Energy, Dispatchability and Availability of BESS) to this Agreement. As more fully set forth in Section 3 (Calculation of Lump Sum Payment) of said Attachment J (Company Payments for Energy, Dispatchability and Availability of BESS), the monthly Lump Sum Payment shall be calculated and adjusted to reflect changes in the estimate of the Facility's Net Energy Potential as such estimate is revised from time to time as more fully set forth in Attachment U (Calculation and Adjustment of Net Energy Potential) to this Agreement. For purposes of calculating the monthly Lump Sum Payment, the monthly Lump Sum Payment shall be adjusted downward to account for the time the Facility inverter(s) are not available for Company Dispatch because of a Force Majeure condition (i) at the Facility or (ii) that otherwise delays or prevents the Seller from making the Facility inverter(s) in question available for Company Dispatch, as more fully set forth in Section 3.iv of Attachment J (Company Payments for Energy, Dispatchability and Availability of BESS) to this Agreement.

2.4 Assurance of Capability of Facility to Deliver Net Energy Potential and Availability of BESS.

- (a) Design, Operation and Maintenance to Achieve Required Performance Metrics; Charging of BESS. In order to provide Company with reasonable assurance that, subject to the Renewable Resource Variability, the Facility's Net Energy Potential will be available for Company Dispatch: (i) the PV System Equivalent Availability Factor Performance Metric shall be used to evaluate the availability of the PV System for dispatch by Company; (ii) the Guaranteed Performance Ratio ("GPR") Performance Metric shall be used to evaluate the efficiency of the PV System; (iii) the BESS Capacity Performance Metric shall be used to confirm the capability of the BESS to discharge continuously for four (4) hours at Maximum Rated Output or to discharge continuously for a total energy (MWh) equal to the BESS Contract Capacity if the test is conducted at less than Maximum Rated Output; (iv) the BESS EAF Performance Metric shall be used to determine whether the BESS is meeting its expected availability; (v) the BESS EFOF Performance Metric shall be used to evaluate whether the

BESS is experiencing excessive unplanned outages; (vi) the RTE Performance Metric shall be used to evaluate the storage efficiency of the BESS; and (vii) the Fast Frequency Response Performance Metric shall be used to measure if the Facility frequency response to Company System frequency is acceptable, consistent with the required Fast Frequency Response and mutually agreed tuning parameters **[DRAFTING NOTE: Subject to removal per Section 2.11 drafting note]**. Whenever the PV System potential output is in excess of the Company Dispatch, the excess energy from the PV System shall be used to maximize the BESS State of Charge so long as this does not conflict with the operating parameters of the BESS set forth in Section 9(d) (Battery Energy Storage System) of Attachment B (Facility Owned by Seller) to this Agreement. Seller shall design, operate and maintain the Facility in a manner consistent with the standard of care reasonably expected of an experienced owner/operator with the desire and financial resources necessary to design, operate and maintain the Facility to achieve the Performance Metrics. The foregoing is without limitation to Seller's other obligations under this Agreement, including the obligation to operate the Facility in accordance with Good Engineering and Operating Practices. The Performance Metrics set forth in Section 2.5 (PV System Equivalent Availability Factor; Liquidated Damages; Termination Rights) through Section 2.11 (Fast Frequency Response Performance Metric) **[DRAFTING NOTE: Subject to removal per Section 2.11 drafting note]** of this Agreement shall be interpreted consistent with the North American Electric Reliability Corporation Generating Availability Data System ("NERC GADS") Data Reporting Instructions.

(b) [Reserved]

2.5 PV System Equivalent Availability Factor; Liquidated Damages; Termination Rights.

(a) Calculation of the PV System Equivalent Availability Factor. Following the end of each LD Period, the PV System Equivalent Availability Factor shall be calculated for such LD Period as follows:

$$= 100\% \times \frac{AH-EPDH-EUDH}{PH}$$

PV System Equivalent
Availability
Factor

where:

Period Hours (PH) is the total number of hours in the LD Period counting twenty-four (24) hours per day minus ExcludedTime. In a normal year, $PH = 8,760$ minus ExcludedTime, and in a leap year $PH = 8,784$ minus ExcludedTime.

Available Hours (AH) is the number of hours that the PV System is not on Outage. It is the sum of all Service Hours (SH) + Reserve Shutdown Hours (RSH).

An "Outage" exists whenever the entire PV System is not online producing electric energy and is not in a Reserve Shutdown state, resulting from Seller-Attributable Non-Generation but excluding ExcludedTime.

Service Hours (SH) is the number of hours during the LD Period the PV System is online and producing electric energy to meet Company Dispatch and/or to maintain the BESS State of Charge.

Reserve Shutdown Hours (RSH) is the number of hours the PV System was available to the Company System but not providing electric energy or is offline for reasons other than Seller-Attributable Non-Generation, or is offline due to insufficient irradiance levels based on the inverter manufacturer's minimum irradiance level for production. All hours except for ExcludedTime between 7:00 pm and 6:00 am will be considered RSH. The PV System will be considered RSH in these hours, even if the system would otherwise be in an outage or derated state.

A "Deration" exists if the Facility is available for Company Dispatch, but at less than full potential output for the given irradiance conditions. Derations include only periods of Seller-Attributable Non-Generation and derations by Company pursuant to Section 8.3 (Company Rights of Dispatch). Derations do not include periods of ExcludedTime. Each individual Deration is

transformed into equivalent full outage hour(s). For Derations due to inverter outages, this is calculated by multiplying the actual duration of the derating (hours) by the number of inverters in the PV System offline and dividing by the total number of inverters in the PV System. For Derations by Company pursuant to Section 8.3 (Company Rights of Dispatch), this is calculated by the size of the Deration (in MW) divided by the Contract Capacity. For avoidance of doubt, if the Facility is in an Outage it cannot also be in a Deration.

Equivalent Planned Derated Hours (EPDH) includes Planned Derations (PD) and Maintenance Derations (D4). A Planned Deration is when the PV System experiences a Deration scheduled well in advance and for a predetermined duration. A Maintenance Deration is a Deration that can be deferred beyond the end of the next weekend (Sunday at midnight or before Sunday turns into Monday) but requires a reduction in capacity before the next Planned Deration (PD). Each individual Deration is transformed into equivalent full outage hour(s).

Equivalent Unplanned Derated Hours (EUDH): An Unplanned Deration (Forced Deration) occurs when the PV System experiences a Deration that requires a reduction in availability before the end of the nearest following weekend. Unplanned Derations include those due to Seller-Attributable Non-Generation. Each individual Unplanned Deration is transformed into equivalent full outage hour(s). For Derations due to inverter outages, this is calculated by multiplying the actual duration of the Deration (in hours) by the number of inverters in the PV System offline and dividing by the total number of inverters in the PV System. For Derations by Company pursuant to Section 8.3 (Company Rights of Dispatch) this is calculated by the size of the deration (in MW) divided by the Contract Capacity. These equivalent hour(s) are then summed.

ExcludedTime is unavailability as a result of the PV System or a portion of the PV System being unavailable due to Force Majeure. The hours and/or equivalent hours of ExcludedTime shall not be added to Available Hours and shall be subtracted from Period Hours. This is calculated by multiplying the actual duration of the

event that counts as ExcludedTime (in hours) by the number of inverters in the PV System offline and dividing by the total number of inverters in the PV System. These equivalent hour(s) are then summed.

The effect of Force Majeure is taken into account in calculating the PV System Equivalent Availability Factor over the 12 calendar month LD Period as follows: When an LD Period contains a month during which the PV System or a portion of the PV System is unavailable due to Force Majeure, then such month shall be excluded from the LD Period and the LD Period shall be extended back in time to include the next previous month during which there was no such unavailability of the PV System or a portion thereof due to Force Majeure.

EXAMPLE: The following is an example of a PV System Equivalent Availability Factor calculation and is included for illustrative purposes only. Assume the following:

1. PV System has 10 inverters.
2. LD Period = first 12 calendar months of the Agreement (non-leap year).
3. PV System was online and producing electric energy for 4,000 hours and was available but not producing electric energy due to lack of sufficient irradiance for production (i.e., not Seller-Attributable Non-Generation) for 500 hours.
4. 3 Inverters were offline for 100 hours due to a Planned Deration between the hours of 6 am and 7 pm.
5. 2 Inverters were offline for 50 hours due to an Unplanned Deration between the hours of 6 am and 7 pm (Seller-Attributable Non-Generation).
6. The PV System was offline for 10 hours due to Force Majeure, which occurred between the hours of 6 am and 7 pm.

The PV System Equivalent Availability Factor would be calculated as follows:

$$\text{Excluded Time} = 10 \text{ hrs}$$

$$\begin{aligned} PH &= 8,760 \text{ hours in 12 calendar months} - 10 \text{ hours of Excluded Time} \\ &= 8,750 \text{ hours} \end{aligned}$$

$$SH = 4,000 \text{ hours}$$

$$RSH = 500 \text{ hours} + (11 \text{ hours/day} \times 365 \text{ days}) = 4,515 \text{ hours}$$

$$AH = SH + RSH = 4,000 \text{ hours} + 4,515 \text{ hours} = 8,515 \text{ hours}$$

$$EPDH = 100 \text{ hours} \times \left(\frac{3 \text{ inverters}}{10 \text{ inverters}} \right) = 30 \text{ hours}$$

$$EUDH = 50 \text{ hours} \times \left(\frac{2 \text{ inverters}}{10 \text{ inverters}} \right) = 10 \text{ hours}$$

$$EAF = 100\% \times \frac{8,515 - 30 - 10}{8,750} = 96.9\%$$

- (b) PV System Equivalent Availability Factor Performance Metric and Liquidated Damages. For each LD Period, a PV System Equivalent Availability Factor shall be calculated as provided in accordance with Section 2.5(a) (Calculation of PV System Equivalent Availability Factor) of this Agreement. In the event the PV System Equivalent Availability Factor is less than 98% (the "PV System Equivalent Availability Factor Performance Metric") for any LD Period, Seller shall be subject to liquidated damages as set forth in this Section 2.5(b) (PV System Equivalent Availability Factor Performance Metric and Liquidated Damages). For avoidance of doubt, because the PV System Equivalent Availability Factor is calculated over an LD Period of 12 calendar months, the first month for which liquidated damages would be calculated under this Section 2.5(b) (PV System Equivalent Availability Factor Performance Metric and Liquidated Damages) would be the last calendar month of the initial Contract Year. If the PV System Equivalent Availability Factor for a LD Period is less than the PV System Equivalent Availability Factor Performance Metric, Seller shall pay, and Company shall accept, as liquidated damages for Seller's failure to achieve the

PV System Equivalent Availability Factor Performance Metric for such LD Period, an amount calculated in accordance with the following formula:

<u>PV System Equivalent Availability Factor</u>	<u>Amount of Liquidated Damages Per Calendar Month</u>
97.9% and below	For each one-tenth of one percent (0.001) by which the PV System Equivalent Availability Factor for such LD Period falls below the PV System Equivalent Availability Factor Performance Metric, an amount equal to 0.001917 of the Applicable Period Lump Sum Payment for the last calendar month of such LD Period.

For purposes of determining liquidated damages under the preceding formula, the amount by which the PV System Equivalent Availability Factor for the LD Period in question falls below the applicable threshold shall be rounded to the nearest one-tenth of one percent (0.001). Each Party agrees and acknowledges that (i) the damages that Company would incur if the Seller fails to achieve the PV System Equivalent Availability Factor Performance Metric for a LD Period would be difficult or impossible to calculate with certainty and (ii) the aforesaid liquidated damages are an appropriate approximation of such damages.

EXAMPLE: The following is an example calculation of liquidated damages for the PV System Equivalent Availability Factor Performance Metric and is included for illustrative purposes only. Assume the monthly Lump Sum Payment is \$1,000,000 and the PV System Equivalent Availability Factor is 96.9% as calculated in the example in Section 2.5(a) (Calculation of the PV System Equivalent Availability Factor) above.

The liquidated damages would be calculated as follows:

Applicable Period Lump Sum Payment = \$1,000,000

$$\$1,000,000 \times .001917 = \$1,917$$

$$98.0\% - 96.9\% = 1.1\%$$

$$1.1\%/0.1\% = 11$$

$$\$1,917 \times 11 = \$21,087$$

- (c) PV System Equivalent Availability Factor Termination Rights. The Parties acknowledge that, although the intent of the liquidated damages payable under Section 2.5(b) (PV System Equivalent Availability Factor Performance Metric and Liquidated Damages) is to compensate Company for the damages that Company would incur if the Seller fails to achieve the PV System Equivalent Availability Factor Performance Metric for a LD Period, such liquidated damages are not intended to compensate Company for the damages that Company would incur if a pattern of underperformance establishes a reasonable expectation that the PV System is likely to continue to substantially underperform the PV System Equivalent Availability Factor Performance Metric. Accordingly, and without limitation to Company's rights under said Section 2.5(b) (PV System Equivalent Availability Factor Performance Metric and Liquidated Damages) for those LD Periods during which the Seller failed to achieve the PV System Equivalent Availability Factor Performance Metric, the failure of the Facility to achieve a PV System Equivalent Availability Factor of not less than **84%** for each of three consecutive Contract Years shall constitute an Event of Default under Section 15.1(b) of this Agreement for which Company shall have the rights (including but not limited to the termination rights) set forth in Article 15 (Events of Default) and Article 16 (Damages in the Event of Termination by Company).

2.6 Measured Performance Ratio; Liquidated Damages; Termination Rights.

(a) Calculation of Measured Performance Ratio.

- (i) The Measured Performance Ratio ("MPR") represents the PV System's measured AC power output compared

to its theoretical DC power output as adjusted for the plane of array irradiance conditions measured at the Site **[Drafting Note: May require revision for DC output]**. The gross PV System output in MW and MVAR will be measured at such point mutually agreed to by the Parties on the Facility's single-line diagram attached hereto as Attachment E (Single-Line Drawing and Interface Block Diagram).

- (ii) Following the end of each MPR Assessment Period, the MPR shall be calculated for such MPR Assessment Period (using the previous 12 months of data) as follows:

$$MPR_{corr} = \frac{\sum_i P_{AC,i}}{\sum_i \left[P_{DCSTC} \left(\frac{G_{POA_i}}{G_{STC}} \right) \left(1 - \frac{\delta}{100} (T_{cell_type_avg} - T_{cell_i}) \right) \right]}$$

Where:

i = each 15-minute interval during the MPR Assessment Period where the inverter input voltage exceeds the PV System inverters minimum level for production

P_{AC_i} is the measured AC power output of the PV System measured at the inverters averaged over time period i in MW

G_{STC} = plane of array irradiance at the standard condition of 1,000 W/m^2

P_{DCSTC} is the DC rated capacity of the PV System at the standard test conditions of 1,000 W/m^2 and 25°C (MW), (i.e., the DC power rating of the PV panels at standard test conditions multiplied by the number of PV panels in the Facility);

G_{POA} is the measured plane of array irradiance averaged over time period i (W/m^2);

T_{cell_i} = cell temperature computed from measured meteorological data (°C) averaged over time period i .

$T_{cell_type_avg}$ = average cell temperature computed from one year of weather data using the project weather file (°C)

δ = temperature coefficient for power (%/°C, negative in sign) that corresponds to the installed modules

$$T_{cell_i} = GPOA * e^{(a+b*WS)} + Ta$$

Where:

T_m = module back-surface temperature [°C]

$GPOA$ = POA irradiance from calibrated reference cells [W/m²]

T_a = ambient temperature [°C]

WS = the measured wind speed corrected to a measurement height of 10 meters [m/s]

a = empirical constant reflecting the increase of module temperature with sunlight

b = empirical constant reflecting the effect of wind speed on the module temperature [s/m]

e = Euler's constant and the base for the natural logarithm.

Table 2. Empirical Convective Heat Transfer Coefficients Module Type	Mount	a	b
Glass/cell/glass	Open rack	-3.47	-0.0594
Glass/cell/glass	Close-roof mount	-2.98	-0.0471
Glass/cell/polymer sheet	Open rack	-3.56	-0.0750
Glass/cell/polymer sheet	Insulated back	-2.81	-0.0455
Polymer/thin-film/steel	Open rack	-3.58	-0.1130

(iii) The time periods used in the foregoing calculation shall be only periods during which, for the entire 15-minute interval, the PV System output

is allowed to convert all irradiance to gross AC power and is not offline due to insufficient irradiance levels based on the inverter minimum requirements for production. Data points that will be excluded are limited to data points where: (A) the G_{POA} is below minimum threshold, (B) G_{POA} above the maximum threshold (C) the PV System is in RSH, (D) when there is a EUDH or EPDH, (E) the PV System was not allowed to convert the full DC output to AC energy; or (F) when there is any other Outage. The aforementioned 15-minute intervals are fixed intervals that commence, in sequence, at the top of each hour and at 15, 30 and 45 minutes past the hour. At the end of each month, Seller shall provide Company a report that lists all hours when such excluded data points occur (from the Facility's SCADA system as necessary) to validate the exclusion of any data points from the calculation set forth in Section 2(a)(ii) above. This information shall be validated on a monthly basis.

- (iv) MPR Test. In the event that the set of operational data points under Section 2.6(a)(iii) that is available for any month to calculate the MPR cannot be validated to Company's reasonable satisfaction or in the event there were not at least 16 such data points during such month that could be used to calculate the MPR, the Company shall have the right to perform a test ("MPR Test") to collect the data points for such month to be used to calculate the MPR in lieu of the use of operational data for such month. The Company shall retain sole discretion as to when to conduct the MPR Test and the MPR Test may be conducted at any point during the month following the month for which Company was either unable to validate the set of operational data points for such month or there were not at least 16 data points available during such month, provided that Company will provide Seller three (3) Business Days' notice prior to conducting the MPR Test. The MPR Test shall have a minimum duration of four (4) hours and shall run until at least 16 data points are collected that meet the criteria set forth in Section 2(a)(iii), subject to the limitation set forth in the last

sentence of this Section 2(a)(iv). To the extent possible, the Company shall schedule the MPR Test for a period where all inverters in the PV System are available and weather conditions are expected to be optimum allowing the PV System to generate at full capacity for the duration of the MPR Test (if possible). However, if Company chooses a period where inverter(s) are unavailable, P_{DCSTC} shall be adjusted to remove the expected contribution of the unavailable inverter(s).

(v) For each MPR Assessment Period that includes one or more months for which a MPR Test was performed, the data points collected during said MPR Test for such month(s) shall be used together with the data points for months for which an MPR Test was not conducted to calculate the MPR for the MPR Assessment Period in question using the formula set forth in Section 2(a)(ii) above. The result of the calculation based on the MPR Test shall be the MPR for the MPR Assessment Period in question.

(vi) EXAMPLE: The following is an example of a Measured Performance Ratio calculation and is included for illustrative purposes only. Assume the following:

1. Facility with 120,000 panels with a standard test condition rating of 300 W
2. $P_{DCSTC} = 120,000 \times 300 \text{ W} = 36 \text{ MW}$
3. For illustrative purposes only, 4 hours of data which met the criteria specified in 2.6(a)(iii) have been recorded over the MPR Assessment Period. It should be noted that all available operational data that meets the criteria specified in Section 2.6(a)(iii) shall be included in the actual calculation.:

Time Period	Average Measured Plane of Array	Average Measured Gross AC Power at	Average Measured Ambient Temperature	Average Measured Wind Speed (m/s)
-------------	---------------------------------	------------------------------------	--------------------------------------	-----------------------------------

	Irradiance (W/m ²)	Inverters (MW)	(°C)	
1	690	16	27	3
2	350	11	26	8
...
i	750	19	29	7

$$MPR_{corr} = \frac{\sum_i P_{AC,i}}{\sum_i \left[P_{DCSTC} \left(\frac{G_{POA_i}}{G_{STC}} \right) \left(1 - \frac{\delta}{100} (T_{cell_type_avg} - T_{cell,i}) \right) \right]}$$

where:

$$T_{cell,i} = G_{POA} \times e^{(a+b \times WS)} + T_a$$

Assuming:

A temperature coefficient of the installed modules of -0.4%/°C

An average cell temperature of 28°C

The installed modules are a glass/cell/polymer sheet module type using an open rack mount. (a = -3.56; b = -0.0750)

$$\sum_i P_{AC,i} = 16 \text{ MW} + 11 \text{ MW} + \dots + 19 \text{ MW} = \mathbf{305 \text{ MW}}$$

$$\begin{aligned} \sum_i \left[P_{DCSTC} \left(\frac{G_{POA_i}}{G_{STC}} \right) \left(1 - \frac{\delta}{100} (T_{cell_type_avg} - T_{cell,i}) \right) \right] &= 36 \text{ MW} \times \\ & [(690/1000) \times (1 - (0.4/100) \times (28 - \\ & ((690/1000) \times e^{(-3.56 - 0.075 \times 3)} + 27))) + \\ & (350/1000) \times (1 - (0.4/100) \times (28 - \\ & ((350/1000) \times e^{(-3.56 - 0.075 \times 8)} + 26))) + \\ & \dots + \\ & (750/1000) \times (1 - (0.4/100) \times (28 - \\ & ((750/1000) \times e^{(-3.56 - 0.075 \times 7)} + 29)))] \\ &= \mathbf{374.76 \text{ MW}} \end{aligned}$$

$$MPR = 305 \text{ MW} / 374.76 \text{ MW} = \mathbf{0.814}$$

(b) Determination of GPR Performance Metric.

- (i) Upon Commencement of Commercial Operations. If a copy of the IE Energy Assessment Report together with the supporting data (plane of array irradiance and corresponding power output) is not provided to

Company in accordance with Section 1(c) (NEP IE Estimate and Company-Designated NEP Estimate) of Attachment U (Calculation and Adjustment of Net Energy Potential), the GPR Performance Metric for the period commencing on the Commercial Operations Date through the end of the calendar month during which the Initial OEPR is issued shall be **0.85**. If a copy of the IE Energy Assessment Report together with the supporting data (plane of array irradiance and corresponding power output) is provided to Company in accordance with Section 1(c) (NEP IE Estimate and Company-Designated NEP Estimate) of Attachment U (Calculation and Adjustment of Net Energy Potential), the GPR Performance Metric shall be the GPR set forth in the IE Energy Assessment Report, provided that such GPR is justified by such supporting data and consistent with the manufacturer's minimum irradiance level for production and point of power measurement specified in Section 2.6(a)(ii). In the event that the IE Assessment Report includes the supporting data (plane of array irradiance and corresponding power output) relied upon in arriving at the NEP IE Estimate, but does not set forth a GPR, the GPR Performance Metric shall be calculated using such supporting data and the Measured Performance Ratio formula in Section 2.6(a)(ii) of this Agreement. Within 30 Days of Company's receipt of the IE Energy Assessment Report together with the aforementioned supporting data, Company shall provide written notice to Seller of either (aa) the GPR Performance Metric derived from such supporting data or (bb) Company's inability to reasonably derive a GPR Performance Metric from such supporting data, in which case the GPR Performance Metric shall be **0.85**.

- (ii) Commencing With Initial OEPR. For the period commencing with the first Day of the calendar month following the establishment of the NEP OEPR Estimate for the Initial OEPR (as provided in Section 2 (Initial OEPR) and Sections 4(g) (Review of the First OEPR Evaluator Report) and (h) (Review of the Second OEPR Evaluator Report) of Attachment U (Calculation and Adjustment of Net Energy

Potential) to this Agreement) through the end of the calendar month during which the NEP OEPR Estimate for the first Subsequent OEPR is established as provided in Section 3 (Subsequent OEPRs) and Sections 4(g) (Review of the First OEPR Evaluator Report) and (h) (Review of the Second OEPR Evaluator Report) of Attachment U (Calculation and Adjustment of Net Energy Potential) to this Agreement, the GPR Performance Metric shall be the GPR as established through the Initial OEPR process as aforementioned. If no GPR has been established through the Initial OEPR process, the GPR Performance Metric shall be **0.85**.

(iii) Commencing With the First Subsequent OEPR and Thereafter. Commencing with the establishment of the NEP OEPR Estimate for the first Subsequent OEPR as provided in Section 3 (Subsequent OEPRs) and Sections 4(g) (Review of the First OEPR Evaluator Report) and (h) (Review of the Second OEPR Evaluator Report) of Attachment U (Calculation and Adjustment of Net Energy Potential) to this Agreement, for each period commencing with the first Day of the calendar month following the establishment of the NEP OEPR Estimate for a Subsequent OEPR (including but not limited to the first Subsequent OEPR) through the end of the calendar month during which the NEP OEPR Estimate is established for the next Subsequent OEPR, the GPR Performance Metric shall be the GPR established for the applicable Subsequent OEPR. If no GPR has been established through the then applicable Subsequent OEPR process, the GPR Performance Metric shall be **0.85**.

(c) GPR Performance Metric and Liquidated Damages. For each MPR Assessment Period, a Measured Performance Ratio shall be calculated as provided in Section 2.6(a) (Calculation of Measured Performance Ratio) of this Agreement. In the event the MPR is less than **95%** of the GPR Performance Metric as adjusted by the degradation factor set forth below, Seller shall pay, and Company shall accept, as liquidated damages for Seller's failure to achieve the GPR Performance Metric for such MPR

Assessment Period, an amount calculated in accordance with the following formula:

<u>Tier</u>	<u>Measured Performance Ratio</u>	<u>Amount of Liquidated Damages Per MPR Assessment Period</u>
Tier 1	GPR Performance Metric x DF x 0.95 > Measured Performance Ratio ≥ GPR Performance Metric x DF x 0.90	For each one-tenth of one percent (0.001) by which the Measured Performance Ratio for such MPR Assessment Period falls below the upper limit of the bandwidth specified in this subparagraph, an amount equal to one-tenth of one percent (0.001) of the MPR Assessment Period Lump Sum Payment. The upper end of the aforementioned bandwidth is equal to the product of the GPR Performance Metric, the applicable degradation factor (DF), and 95%. The lower limit of the aforementioned bandwidth consists of and includes the product of the GPR Performance Metric, the applicable degradation factor (DF), and 90%; plus
Tier 2	GPR Performance Metric x DF x 0.90 > Measured Performance Ratio ≥ GPR Performance Metric x DF x 0.80	For each one-tenth of one percent (0.001) by which the Measured Performance Ratio for such MPR Assessment Period falls below the upper limit of the bandwidth specified in this subparagraph, an amount equal to two-tenths of one percent (0.002) of the MPR Assessment Period Lump Sum Payment. The

upper end of the
aforementioned bandwidth is
equal to the product of the
GPR Performance Metric, the
applicable degradation
factor (DF), and 90%. The
lower limit of the
aforementioned bandwidth
consists of and includes
the product of the GPR
Performance Metric, the
applicable degradation
factor (DF), and 80%; plus

**Measured
Performance
Ratio < GPR
Performance
Metric x DF x
0.80**

For each one-tenth of one
percent (0.001) by which
the Measured Performance
Ratio for such MPR
Assessment Period falls
below the product of the
GPR Performance Metric, the
applicable degradation
factor (DF), and 80%, an
amount equal to four-tenths
of one percent (0.004) of
the MPR Assessment Period
Lump Sum Payment.

For purposes of the foregoing calculations under this
Section 2.6(c) (GPR Performance Metric and Liquidated
Damages), the degradation factor (DF) is calculated for
each Contract Year (e.g., second Contract Year, third
Contract Year, fourth Contract Year, etc.) as follows:
 $DF = 1 - 0.005 * (\text{Applicable Contract Year} - 1)$. For purposes of the
foregoing formula, the "Applicable Contract Year" is the
Contract Year within which the calendar month in
question falls. If all of the months of an MPR
Assessment Period fall within the same Contract Year,
the Contract Year is the "Applicable Contract Year."
For example, if all of the months of MPR Assessment
Period fall within the third Contract Year, the value
assigned to the "Applicable Contract Year" would be "3"
and the formula for calculating the DF for such LD
Period would be: $DF = 1 - 0.005 * (3 - 1)$. However, because
the MPR Assessment Period is a rolling 12-month period,

the MPR Assessment Period will often straddle two consecutive Contract Years. In such cases, all of the months falling within the same Contract Year will be assigned the value for such Contract Year and the value assigned to the "Applicable Contract Year" for purposes of the foregoing formula shall be the average of the assigned monthly values for such 12-month MPR Assessment Period. For example, for an MPR Assessment Period which has four months in the third Contract Year and eight months in the fourth Contract Year, the value assigned to the "Applicable Contract Year" for such MPR Assessment Period would be 3.67, as calculated as follows:

$$\frac{(3 \times 4) + (4 \times 8)}{12}$$

and the formula for calculating the DF for such MPR Assessment Period would be $DF = 1 - 0.005 * (3.67 - 1)$. For purposes of determining liquidated damages under this Section 2.6(c) (GPR Performance Metric and Liquidated Damages), the amount by which the Measured Performance Ratio for the MPR Assessment Period in question falls below the applicable threshold shall be rounded to the nearest one-tenth of one percent (0.001). Each Party agrees and acknowledges that (i) the damages that Company would incur if the Seller fails to achieve the GPR Performance Metric for a MPR Assessment Period would be difficult or impossible to calculate with certainty and (ii) the aforesaid liquidated damages are an appropriate approximation of such damages.

EXAMPLE: The following is an example calculation of liquidated damages for the GPR Performance Metric and is included for illustrative purposes only. Assume the following facts:

The MPR Assessment Period has five months in the second Contract Year and seven months in the third Contract Year.

The GPR for the Facility as determined by the OEPR is 0.9.

The MPR has been calculated to be 0.694.

Applicable Contract Year = $[(5 \times 2) + (7 \times 3)]/12 = 2.58$

DF = $1 - 0.005 * (2.58 - 1) = 0.9921$

Upper limit of the Tier 1 bandwidth = $0.9 \times 0.9921 \times 0.95 = 0.848$

Lower limit of the Tier 1 bandwidth/Upper limit of the Tier 2 bandwidth = $0.9 \times 0.9921 \times 0.9 = 0.804$

Lower limit of the Tier 2 bandwidth = $0.8 \times 0.9921 \times 0.9 = 0.714$

LD = $[(0.848 - 0.804) \times 1) + ((0.804 - 0.714) \times 2) + ((0.714 - 0.694) \times 4)] \times \text{MPR Assessment Period Lump Sum Payment}$
= $0.304 \times \text{MPR Assessment Period Lump Sum Payment}$

- (d) MPR Termination Rights. The Parties acknowledge that, although the intent of the liquidated damages payable under Section 2.6(c) (GPR Performance Metric and Liquidated Damages) is to compensate Company for the damages that Company would incur if the Seller fails to achieve the GPR Performance Metric for a MPR Assessment Period, such liquidated damages are not intended to compensate Company for the damages that Company would incur if a pattern of underperformance establishes a reasonable expectation that the Facility is likely to continue to substantially underperform the GPR Performance Metric. Accordingly, and without limitation to Company's rights under said Section 2.6(c) (GPR Performance Metric and Liquidated Damages) for those MPR Assessment Periods during which the Seller failed to achieve the GPR Performance Metric, the failure of the PV System to achieve, for each of three consecutive Contract Years, a Measured Performance Ratio of not less than the Tier 2 Bandwidth for such Contract Year shall constitute an Event of Default under Section 15.1(c) of this Agreement for which Company shall have the rights (including but not limited to the termination rights) set forth in Article 15 (Events of Default) and Article 16 (Damages in the Event of Termination by Company).

2.7 BESS Capacity Test; Liquidated Damages; Termination Rights.

- (a) BESS Capacity Test and Liquidated Damages. For each BESS Measurement Period following the Commercial Operations Date, the BESS shall be required to complete a BESS Capacity Test, as more fully set forth in Attachment W (BESS Tests) to this Agreement. For each BESS Measurement Period for which the BESS fails to demonstrate that it satisfies the BESS Capacity Performance Metric, Seller shall pay, and Company shall accept, as liquidated damages for such shortfall, the amount set forth in the following table (on a progressive basis) upon proper demand at the end the BESS Measurement Period in question:

BESS Capacity Ratio	Liquidated Damage Amount
Tier 1 95.0% - 99.9%	For each one-tenth of one percent (0.001) that the BESS Capacity Ratio is below 100% and is equal to or greater than 95.0%, an amount equal to one-tenth of one percent (0.001) of the BESS Allocated Portion of the Lump Sum Payment for the BESS Measurement Period in question; plus
Tier 2 85.0% - 94.9%	For each one-tenth of one percent (0.001) that the BESS Capacity Ratio is below 95% and is above 84.9%, an amount equal to one and a half-tenths of one percent (0.0015) of the BESS Allocated Portion of the Lump Sum Payment for the BESS Measurement Period in question; plus
Tier 3 75.0% - 84.9%	For each one-tenth of one percent (0.001) that the BESS Capacity Ratio is below 85% and is above 74.9%, an amount equal to

	two-tenths of one percent (0.002) of the BESS Allocated Portion of the Lump Sum Payment for the BESS Measurement Period in question; plus
Tier 4 60.0% - 74.9%	For each one-tenth of one percent (0.001) that the BESS Capacity Ratio is below 75% and is above 59.9%, an amount equal to two and a half-tenths of one percent (0.0025) of the BESS Allocated Portion of the Lump Sum Payment for the BESS Measurement Period in question; plus
Tier 5 50.0% - 59.9%	For each one-tenth of one percent (0.001) that the BESS Capacity Ratio is below 60% and is above 49.9%, an amount equal to three-tenths of one percent (0.003) of the BESS Allocated Portion of the Lump Sum Payment for the BESS Measurement Period in question; plus
Tier 6 49.9% and below ("Lowest BESS Capacity Bandwidth")	For each one-tenth of one percent (0.001) that the BESS Capacity Ratio is below 50%, an amount equal to three and a half-tenths of one percent (0.0035) of the BESS Allocated Portion of the Lump Sum Payment for the BESS Measurement Period in question.

For purposes of determining liquidated damages under this Section 2.7(a) (BESS Capacity Test and Liquidated

Damages), the starting and end points for the duration of the period that the BESS discharges shall be rounded to the nearest MWh. Each Party agrees and acknowledges that (i) the damages that Company would incur if the Seller fails to achieve the BESS Capacity Performance Metric for a BESS Measurement Period would be difficult or impossible to calculate with certainty and (ii) the aforesaid liquidated damages are an appropriate approximation of such damages.

EXAMPLE: The following is an example calculation of liquidated damages for the BESS Capacity Performance Metric and is included for illustrative purposes only. Assume the following:

The Maximum Rated Output for the BESS is 25 MW.

A BESS Capacity Test was conducted and the BESS was measured to have discharged 65 MWh

BESS Contract Capacity = 25 MW x 4 hours = 100 MWh
BESS Capacity Ratio = MWh Discharged/BESS Contract Capacity = 65 MWh/100 MWh = 0.65

$LD = [(1 - 0.950) \times 1] + [(0.950 - 0.850) \times 1.5] + [(0.850 - 0.750) \times 2] + [(0.750 - 0.65) \times 2.5] \times \text{BESS Allocated Portion of the Lump Sum Payment for the BESS Measurement Period in question}$
 $= 0.65 \times \text{BESS Allocated Portion of the Lump Sum Payment for the BESS Measurement Period in question}$

- (b) BESS Capacity Test Termination Rights. The Parties acknowledge that, although the intent of the liquidated damages payable under Section 2.7(a) (BESS Capacity Test and Liquidated Damages) is to compensate Company for the damages that Company would incur if the BESS fails to demonstrate satisfaction of the BESS Capacity Performance Metric during a BESS Measurement Period, such liquidated damages are not intended to compensate Company for the damages that Company would incur if a pattern of underperformance establishes a reasonable expectation that the BESS is likely to continue to substantially underperform the Company's expectations. Accordingly, and without limitation to Company's rights under said Section 2.7(a) (BESS Capacity Test and

Liquidated Damages) for those BESS Measurement Periods during which the BESS fails to demonstrate satisfaction of the BESS Capacity Performance Metric, substantial underperformance shall give rise to a termination right as set forth in this Section 2.7(b) (BESS Capacity Test Termination Rights). If the BESS is in the Lowest BESS Capacity Bandwidth for any two BESS Measurement Periods during a 12-month period, an 18-month cure period (the "BESS Capacity Cure Period") will commence on the Day following the close of the second such BESS Measurement Period. For each BESS Measurement Period during such BESS Capacity Cure Period, BESS Capacity Tests shall continue to be conducted as set forth in Attachment W (BESS Tests) and liquidated damages paid and accepted as set forth in Section 2.7(a) (BESS Capacity Test and Liquidated Damages); provided, however, that if the Seller fails to demonstrate satisfaction of the BESS Capacity Performance Metric prior to the expiration of the BESS Capacity Cure Period, such failure shall constitute an Event of Default under Section 15.1(d) of this Agreement for which Company shall have the rights (including but not limited to the termination rights) set forth in Article 15 (Events of Default) and Article 16 (Damages in the Event of Termination by Company).

2.8 BESS Annual Equivalent Availability Factor; Liquidated Damages; Termination Rights.

- (a) BESS Annual Equivalent Availability Factor and Liquidated Damages. For each BESS Measurement Period following the Commercial Operations Date, a BESS Annual Equivalent Availability Factor shall be calculated as set forth in Attachment X (BESS Annual Equivalent Availability Factor). If the BESS Annual Equivalent Availability Factor for such BESS Measurement Period is less than **97%** (the "BESS EAF Performance Metric"), Seller shall pay, and Company shall accept, as liquidated damages for such shortfall, the amount set forth in the following table (on a progressive basis) upon proper demand at the end the current BESS Measurement Period:

BESS Annual Equivalent Availability Factor	Liquidated Damage Amount
---	---------------------------------

<p>Tier 1 85.0% - 96.9%</p>	<p>For each one-tenth of one percent (0.001) by which the BESS Annual Equivalent Availability Factor falls below 97% but equal to or above 85%, an amount equal to one-tenth of one percent (0.001) of the BESS Allocated Portion of the Lump Sum Payment for the BESS Measurement Period in question; plus</p>
<p>Tier 2 80.0% - 84.9%</p>	<p>For each one-tenth of one percent (0.001) by which the BESS Annual Equivalent Availability Factor falls below 85% but equal to or above 80%, an amount equal to two-tenths of one percent (0.002) of the BESS Allocated Portion of the Lump Sum Payment for the BESS Measurement Period in question; plus</p>
<p>Tier 3 75.0% - 79.9%</p>	<p>For each one-tenth of one percent (0.001) by which the BESS Annual Equivalent Availability Factor falls below 80% but equal to or above 75%, an amount equal to three-tenths of one percent (0.003) of the BESS Allocated Portion of the Lump Sum Payment for the BESS Measurement Period in question; plus</p>
<p>Tier 4 Below 75.0%</p>	<p>For each one-tenth of one percent (0.001) by which the BESS Annual Equivalent Availability Factor falls below 75%, an amount equal to four-tenths of one percent (0.004) of the BESS Allocated Portion of the Lump Sum Payment for the BESS</p>

	Measurement Period in question.
--	---------------------------------

Such liquidated damages shall be due within thirty (30) Days after the first to occur of the end of such BESS Measurement Period or the end of Term. In the event Seller fails to pay Company amounts of liquidated damages due under this Section 2.8(a) (BESS Annual Equivalent Availability Factor and Liquidated Damages) within thirty (30) Days of receipt of Company's written demand, Company may, without limitation to any other remedy Company may have, set-off such amounts due against payments it is otherwise obligated to make under this Agreement.

For purposes of determining liquidated damages under this Section 2.8(a) (BESS Annual Equivalent Availability Factor and Liquidated Damages), the BESS Annual Equivalent Availability Factor for the BESS Measurement Period in question shall be rounded to the nearest one-tenth of one percent (0.001). Each Party agrees and acknowledges that (i) the damages that Company would incur if the Seller fails to achieve the BESS EAF Performance Metric for a BESS Measurement Period would be difficult or impossible to calculate with certainty and (ii) the aforesaid liquidated damages are an appropriate approximation of such damages.

- (b) BESS Annual Equivalent Availability Factor Termination Rights. The Parties acknowledge that, although the intent of the liquidated damages payable under Section 2.8(a) (BESS Annual Equivalent Availability Factor and Liquidated Damages) is to compensate Company for the damages that Company would incur if the Seller fails to achieve the BESS EAF Performance Metric for a BESS Measurement Period, such liquidated damages are not intended to compensate Company for the damages that Company would incur if a pattern of underperformance establishes a reasonable expectation that the BESS is likely to continue to substantially underperform the BESS EAF Performance Metric. Accordingly, and without limitation to Company's rights under said Section 2.8(a) (BESS Annual Equivalent Availability Factor and Liquidated Damages) for those BESS Measurement Periods during which the Seller failed to achieve the BESS EAF

Performance Metric, the failure of the Seller to achieve, for each of four consecutive BESS Measurement Periods, a BESS Annual Equivalent Availability Factor of not less than **75%** shall constitute an Event of Default under Section 15.1(e) of this Agreement for which Company shall have the rights (including but not limited to the termination rights) set forth in Article 15 (Events of Default) and Article 16 (Damages in the Event of Termination by Company); provided, however, that if a BESS Measurement Period for which the aforementioned 75% threshold is not achieved falls within a BESS Capacity Cure Period, such BESS Measurement Period shall be excluded from the calculation of the aforementioned "four consecutive BESS Measurement Periods" if the failure to achieve the aforementioned 75% threshold was the result of unavailability caused by the process of carrying out the repairs to or replacements of the BESS necessary to remedy the failure of the BESS to achieve the BESS Capacity Performance Metric.

2.9 BESS Annual Equivalent Forced Outage Factor; Liquidated Damages.

For each BESS Measurement Period following the Commercial Operations Date, the BESS shall maintain a BESS Annual Equivalent Forced Outage Factor of not more than 4% (the "BESS EFOF Performance Metric") as calculated as set forth in Attachment Y (BESS Annual Equivalent Forced Outage Factor). If the BESS Annual Equivalent Forced Outage Factor for such BESS Measurement Period exceeds the BESS EFOF Performance Metric, Seller shall pay, and Company shall accept, as liquidated damages for exceeding the BESS EFOF Performance Metric, the amount set forth in the following table (on a progressive basis) upon proper demand by the Company at the end of the BESS Measurement Period in question:

BESS Annual Equivalent Forced Outage Factor	Liquidated Damage Amount
0.0% - 4.0%	-0-
4.1% - 6.9%	For each one-tenth of one percent (0.001) that the BESS Annual Equivalent Forced Outage Factor is above 4.0% but less than

	7.0%, an amount equal to two-tenths of one percent (0.002) of the BESS Allocated Portion of the Lump Sum Payment for the BESS Measurement Period in question; plus
7.0% and above	For each one-tenth of one percent (0.001) that the BESS Annual Equivalent Forced Outage Factor is above 6.9%, an amount equal to four-tenths of one percent (0.004) of the BESS Allocated Portion of the Lump Sum Payment for the BESS Measurement Period in question

Such liquidated damages shall be due within thirty (30) Days after the first to occur of the end of such BESS Measurement Period or the end of Term. In the event Seller fails to pay Company amounts of liquidated damages due under this Section 2.9 (BESS Annual Equivalent Forced Outage Factor; Liquidated Damages) within thirty (30) Days of receipt of Company's written demand, Company may set-off such amounts due against payments it is otherwise obligated to make under this Agreement.

For purposes of determining liquidated damages under this Section 2.9 (BESS Annual Equivalent Forced Outage Factor; Liquidated Damages), the BESS Annual Equivalent Forced Outage Factor for the BESS Measurement Period in question shall be rounded to the nearest one-tenth of one percent (0.001). Each Party agrees and acknowledges that (i) the damages that Company would incur if the Seller fails to achieve the BESS EFOF Performance Metric for a BESS Measurement Period would be difficult or impossible to calculate with certainty and (ii) the aforesaid liquidated damages are an appropriate approximation of such damages.

For example, if the BESS Equivalent Annual Forced Outage Factor was 4.1% as calculated in the example in Attachment Y (BESS Annual Equivalent Forced Outage Factor) attached hereto

and the BESS Allocated Portion of the Lump Sum Payment for the BESS Measurement Period in question is \$1,000,000, the liquidated damages would be \$2,000, calculated as follows:

$$\begin{aligned} 4.1\% - 4.0\% &= 0.1\% \\ 0.1\%/0.1 &= 1 \\ \$1,000,000 \times .002 &= \$2,000 \\ \$2,000 \times 1 &= \$2,000 \end{aligned}$$

2.10 BESS Round Trip Efficiency Test; Liquidated Damages; Termination Rights.

(a) RTE Test and Liquidated Damages. For each BESS Measurement Period following the Commercial Operations Date, the BESS shall be required to complete a RTE Test or otherwise demonstrate satisfaction of the RTE Performance Metric, as more fully set forth in Attachment W (BESS Tests) to this Agreement. For each BESS Measurement Period for which the BESS fails to demonstrate that it satisfies the RTE Performance Metric, Seller shall pay, and Company shall accept, as liquidated damages for such shortfall, in the amount to be calculated as provided in this Section 2.10(a) (RTE Test and Liquidated Damages), upon proper demand at the end the BESS Measurement Period in question.

The RTE Performance Metric is % as measured at the Point of Interconnection. **[DRAFTING NOTE: PERCENTAGE TO BE TAKEN FROM RESPONSE TO RFP.]**

The liquidated damages threshold ("LDT") is equal to the RTE Performance Metric minus 2 percentage points.

The Selected RTE Test is the RTE Test that came closest to satisfying the RTE Performance Metric during the BESS Measurement Period in question.

Seller shall be liable for liquidated damages if:

$$(PM - RTE Ratio) * 100 > 2\%$$

Where:

PM = RTE Performance Metric stated as percentage

RTE Ratio = RTE Ratio from Selected RTE Test stated as percentage

For each percentage point by which the RTE Ratio is below the LDT, Seller shall pay, and Company shall accept, liquidated damages in an amount equal to two-tenths of one percent (0.002) of the BESS Allocated Portion of the Lump Sum Payment for the BESS Measurement Period in question.

Each Party agrees and acknowledges that (i) the damages that Company would incur if the Seller fails to achieve the RTE Performance Metric for a BESS Measurement Period would be difficult or impossible to calculate with certainty and (ii) the aforesaid liquidated damages are an appropriate approximation of such damages.

- (b) RTE Test Termination Rights. The Parties acknowledge that, although the intent of the liquidated damages payable under Section 2.10(a) (RTE Test and Liquidated Damages) is to compensate Company for the damages that Company would incur if the BESS fails to demonstrate satisfaction of the RTE Performance Metric during a BESS Measurement Period, such liquidated damages are not intended to compensate Company for the damages that Company would incur if a pattern of underperformance establishes a reasonable expectation that the BESS is likely to continue to substantially underperform the Company's expectations. Accordingly, and without limitation to Company's rights under said Section 2.10(a) (RTE Test and Liquidated Damages) for those BESS Measurement Periods during which the BESS fails to demonstrate satisfaction of the RTE Performance Metric, substantial underperformance shall give rise to a termination right as set forth in this Section 2.10(b) (RTE Test Termination Rights). If the RTE Ratio for the Selected RTE Test for the BESS Measurement Period in question is more than 15 percentage points below the RTE Performance Metric for any two BESS Measurement Periods during a 12-month period, an **18-month** cure period (the "RTE Cure Period") will commence on the Day following the close of the second such BESS Measurement Period. For each BESS Measurement Period during such RTE Cure Period, RTE Tests shall continue to be conducted as set forth in Attachment W (BESS Tests) and liquidated damages paid and accepted as set forth in Section 2.10(a) (RTE Test and Liquidated Damages); provided,

however, that if the Seller fails to demonstrate satisfaction of the RTE Performance Metric prior to the expiration of the RTE Cure Period, such failure shall constitute an Event of Default under Section 15.1(f) of this Agreement for which Company shall have the rights (including but not limited to the termination rights) set forth in Article 15 (Events of Default) and Article 16 (Damages in the Event of Termination by Company).

2.11 Fast Frequency Response Performance Metric. **[DRAFTING NOTE: SECTION 2.11 APPLIES ONLY TO PROJECTS THAT INCLUDE CONTINGENCY STORAGE IN THEIR PROPOSALS. IT WILL BE REMOVED FROM PROJECTS THAT DO NOT INCLUDE CONTINGENCY STORAGE.]**

- (a) Fast Frequency Response Criteria and Liquidated Damages. Following the Commercial Operations Date, the Facility shall respond appropriately to frequency disturbances in the Company System by operating in a manner consistent with standards and parameters established for Fast Frequency Response. With respect to such frequency disturbances in the Company System, the Facility shall be required to meet all of the following minimum frequency performance criteria (collectively, the "Fast Frequency Response Performance Metric"):
- (i) The time between a step change in frequency and the response is no more than 1.3 times the target reaction time;
 - (ii) The resource achieves at least 63% of the new steady state active power output within the rise time;
 - (iii) The resource achieves at least 70% of the new steady state active power target within the settling time;
 - (iv) Overshoot does not exceed 5% of the final steady state active power; and
 - (v) The new steady-state active power output is within the settling band.

Company will review historical operational data to determine the Facility's fast frequency response following disturbances

and satisfaction of the Fast Frequency Response Performance Metric. In accordance with Section 8(v) (Data Collection) of Attachment B (Facility Owned by Seller), Seller shall provide such high resolution data from the Facility requested by Company to assist in the review. To the extent the historical operational data is insufficient or otherwise lacking for purposes of determining the Facility's satisfaction of the Fast Frequency Response Performance Metric, Company shall review Facility's performance under structured test conditions no less than once per Contract Year.

After the first Contract Year:

- (1) for each instance of the Facility failing to satisfy the Fast Frequency Response Performance Metric, Seller shall pay, and Company shall accept, as liquidated damages for such failure, an amount equal to 25% of the FFR Allocated Portion of the Lump Sum Payment upon proper demand by Company; and
- (2) in the event poor Facility fast frequency response performance requires disabling the fast frequency response controls, as determined by Company in its sole discretion (e.g., in the event a Facility response to Company System frequency outside of the FFR deadband contributes to frequency error or worsens the disturbance), Seller shall pay and Company shall accept, as liquidated damages for such underperformance, an amount equal to 100% of the FFR Allocated Portion of the Lump Sum Payment upon proper demand by Company, and Seller shall not be entitled to receive further payments of the FFR Allocated Portion of the Lump Sum Payment while the Facility fast frequency response controls remain disabled to allow Seller to perform corrective actions on the Facility to Company's reasonable satisfaction.

Such liquidated damages shall be due within thirty (30) Days of Company's written demand.

Company agrees that, when evaluating performance under this Section 2.11 (Fast Frequency Response Performance Metric),

the available State of Charge shall be taken into consideration and Seller shall not be held to the criteria set forth in this Section 2.11 (Fast Frequency Response Performance Metric) if there is insufficient charged capacity available for the appropriate response.

- (b) Performance Deficiencies; Fast Frequency Response Performance Factor Termination Rights. With respect to any Facility response under this Section 2.11 (Fast Frequency Response Performance Metric), Company will notify Seller of any discrepancies in the Facility response, and Seller shall respond to and cure all such performance deficiencies in accordance with Section 1(j) (Demonstration of Facility) of Attachment B (Facility Owned by Seller). The Parties acknowledge that, although the intent of the liquidated damages payable under Section 2.11(a) (Fast Frequency Response Criteria and Liquidated Damages) is to compensate Company for the damages that Company would incur if the Facility fails to respond appropriately to Company System frequency, such liquidated damages are not intended to compensate Company for the damages that Company would incur if a pattern of underperformance establishes a reasonable expectation that the Facility is likely to continue to substantially underperform. Accordingly, and without limitation to Company's rights under said Section 2.11(a) (Fast Frequency Response Criteria and Liquidated Damages), in the event Seller fails to comply with the terms of Section 1(j) (Demonstration of Facility) of Attachment B (Facility Owned by Seller), such event shall constitute an Event of Default under Section 15.2(f) of this Agreement for which Company shall have the rights (including but not limited to the termination rights) set forth in Article 15 (Events of Default) and Article 16 (Damages in the Event of Termination).

2.12 Payment of Liquidated Damages for Failure to Achieve Performance Metrics; Limitation on Liquidated Damage.

- (a) Payment of Liquidated Damages. With respect to the liquidated damages payable under Section 2.5(b) (PV System Equivalent Availability Factor Performance Metric and Liquidated Damages), Section 2.6(c) (GPR Performance Metric and Liquidated Damages), Section 2.7(a) (BESS Capacity Test and Liquidated Damages), Section 2.8(a)

(BESS Annual Equivalent Availability Factor and Liquidated Damages), Section 2.9 (BESS Annual Equivalent Forced Outage Factor; Liquidated Damages) and Section 2.10 (BESS Round Trip Efficiency Test; Liquidated Damages; Termination Rights) and Section 2.11 (Fast Frequency Response Performance Metric) **[SUBJECT TO REMOVAL PER SECTION 2.11 DRAFTING NOTE]** (collectively, the "Performance Metrics LDs"), Company shall have the right, at any time on or after the LD Assessment Date for the liquidated damages in question, at Company's option, to set-off such liquidated damages from the amounts to be paid to Seller under Section 2.3 (Lump Sum Payment) of this Agreement or, to draw such liquidated damages from the Operating Period Security, as follows:

- (i) if the BESS fails to achieve the BESS Capacity Performance Metric for a BESS Measurement Period, the Company shall have the right to set-off or draw the amount owed for such failure as calculated as provided in Section 2.7(a) (BESS Capacity Test and Liquidated Damages); and
- (ii) if the Monthly Report for the calendar month, MPR Assessment Period, or BESS Measurement Period in question, as applicable, shows a failure to achieve one or more of the Performance Metrics required for the LD Period in question, the MPR Measurement Period in question, or the BESS Measurement Period in question, as applicable, and Company does not submit a Notice of Disagreement with respect to such Monthly Report, the Company shall have the right to set-off or draw the amount of liquidated damages owed for such failure as calculated as provided in Section 2.5(b) (PV System Equivalent Availability Factor Performance Metric and Liquidated Damages), Section 2.6(c) (GPR Performance Metric and Liquidated Damages), Section 2.8(a) (BESS Annual Equivalent Availability Factor and Liquidated Damages), Section 2.9 (BESS Annual Equivalent Forced Outage Factor; Liquidated Damages), Section 2.10 (BESS Round Trip Efficiency Test; Liquidated Damages; Termination Rights) and Section 2.11 (Fast Frequency Response Performance Metric) **[SUBJECT TO REMOVAL PER SECTION 2.11 DRAFTING NOTE]**, as applicable;

- (iii) in all cases in which Company submits a Notice of Disagreement for a given Monthly Report, Company shall have the right to set-off or draw all or any portion of the amount of liquidated damages for the calendar month in question, MPR Assessment Period in question, or BESS Measurement Period in question, as applicable, as calculated on the basis of the shortfall(s) in the achievement of the Performance Metric(s) in question, as shown in such Notice of Disagreement; and
- (iv) in the event of any disagreement as to the liquidated damages owed under clause (i) and (iii) above:
 - (aa) if the amount set-off or drawn by the Company exceeds the amount of liquidated damages for such calendar month, BESS Measurement Period or MPR Assessment Period that are eventually found to be payable for the LD Period in question as determined under Section 2 (Monthly Report Disagreements) of Attachment T (Monthly Reporting and Dispute Resolution by Independent AF Evaluator) to this Agreement, Company shall promptly (and in no event more than forty-five (45) Business Days from the date of such determination) repay such excess to Seller together with, unless the Parties otherwise agree in writing, interest from the date of Company's set-off or draw until the date that such excess is repaid to Seller at the average Prime Rate for such period; and
 - (bb) if Company does not exercise its rights to set-off or draw liquidated damages for such calendar month, BESS Measurement Period or MPR Assessment Period, or does not set-off or draw the full amount of the liquidated damages for such calendar month, BESS Measurement Period or MPR Assessment Period that are eventually found to be payable for the LD Period, BESS Measurement Period or MPR Assessment Period in question as determined under Section 2 (Monthly Report Disagreements) of Attachment T (Monthly Reporting and Dispute Resolution by

Independent AF Evaluator) to this Agreement, Seller shall promptly, upon such determination as aforesaid, pay to Company the amount of liquidated damages that are found to be owing together with, unless otherwise agreed by the Parties in writing, interest on the amount of such liquidated damages that went unpaid from the applicable LD Assessment Date for such liquidated damages until the date such liquidated damages are paid to Company in full at the average Prime Rate for such period, and Company shall have the right, at its option, to set-off such interest for the amounts to be paid to Seller under Section 2.3 (Lump Sum Payment) of this Agreement or to draw from the Operating Period Security.

Any delay by Company in exercising its rights to set-off liquidated damages and/or interest from the amounts to be paid to Seller under Section 2.3 (Lump Sum Payment) of this Agreement or to draw such liquidated damages and/or interest from the Operating Period Security shall not constitute a waiver by Company of its right to do so.

- (b) Limitation on Liquidated Damages. Notwithstanding any other provision of this Agreement to the contrary, the aggregate liquidated damages paid by Seller during each Contract Year for the Performance Metrics LDs, such payments by Seller to include but not be limited to any set-offs or draws made by Company during such Contract Year pursuant to Section 2.12(a) (Payment of Liquidated Damages), shall not exceed the total of the twelve (12) monthly Lump Sum Payments payable during such Contract Year pursuant to Section 2.3 (Lump Sum Payment) and Section 2.17 (Payment Procedures). For avoidance of doubt: A monthly Lump Sum Payment that is invoiced by Seller to Company pursuant to Section 2.16 (Seller's Preparation of the Monthly Invoice) for, e.g., the twelfth (12th) calendar month of Contract Year N but is paid during Contract Year N+1 as provided in Section 2.17 (Payment Procedures) shall, for purposes of determining the limitation on Performance Metrics LDs under this Section 2.12(b) (Limitation on Liquidated Damages), be included in the total of the twelve (12) monthly Lump Sum Payments payable during Contract Year

N+1. As a result of the foregoing, the total of the monthly Lump Sum Payments used to establish the limitation on Performance Metrics LDs for the initial Contract Year under this Section 2.12(b) (Limitation on Liquidated Damages) will be less than twelve (12). The Parties acknowledge that, because the monthly Lump Sum Payment is subject to adjustment (including downward adjustment) as provided in Section 2.3 (Lump Sum Payment), it is possible that a downward adjustment in some or all of the monthly Lump Sum Payments payable during a Contract Year might cause the Performance Metrics LDs paid by Seller during the course of such Contract Year to exceed the limitation on the Performance Metrics LDs for such Contract Year established at the close of such Contract Year pursuant to the first sentence of this Section 2.12(b) (Limitation on Liquidated Damages). In such case, Company shall promptly upon the determination that the Performance Metrics LDs paid during the course of such Contract Year exceeded the limitation on Performance Metrics LDs for such Contract Year (and in no event more than forty-five (45) Business Days from the end of such Contract Year) repay such excess amount to Seller without interest.

2.13 No Payments Prior to Commercial Operations Date. Prior to the Commercial Operations Date, Company may accept test energy delivered by Seller in accordance with Section 4 (Test Energy) of Attachment J (Company Payments for Energy, Dispatchability and Availability of BESS). Company shall not be obligated to pay for any test energy accepted prior to the Commercial Operations Date.

2.14 Sales of Electric Energy by Company to Seller. Sales of electric energy by Company to Seller shall be governed by an applicable rate schedule filed with the PUC and not by this Agreement, except with respect to the reactive amount adjustment (if any) referred to in Attachment B (Facility Owned by Seller).

2.15 [Reserved] **[Drafting Note: Use the following if PPA has energy payment:** Company's Obligation to Provide Certain Data. By the fifth (5th) Business Day of each calendar month, Company shall provide Seller or its designated agent with the appropriate data for Seller to compute the amount to be

paid for the electric energy purchased by Company in the preceding calendar month as determined in accordance with this Agreement.]

- 2.16 Seller's Preparation of the Monthly Invoice. By the tenth (10th) Business Day of each calendar month, Seller shall submit to Company an invoice that separately states the following for the preceding month: (i) the Actual Output during this period; (ii) the monthly Lump Sum Payment for this period; and (iii) the monthly metering charge as set forth in Article 7 (Seller Payments) of this Agreement. **[Drafting Note: Add the following subclause if PPA has energy payment: "(iv) the charge for electric energy purchased by Company, as set forth in Attachment J (Company Payments for Energy, Dispatchability and Availability of BESS) of this Agreement."]**
- 2.17 Payment Procedures. By the twentieth (20th) Business Day of each calendar month following the month during which the invoice was submitted (i.e., by the twentieth (20th) Business Day of the second calendar month following the calendar month covered by the invoice in question), (but, except as otherwise provided in the following sentence, no later than the last Business Day of that month if there are less than twenty (20) Business Days in that month), Company shall, subject to Company's right to set-off liquidated damages as provided in Section 2.12 (Payment of Liquidated Damages for Failure to Achieve Performance Metrics; Limitation on Liquidated Damages) of this Agreement, make payment on such invoice, or provide to Seller an itemized statement of its objections to all or any portion of such invoice and pay any undisputed amount. Notwithstanding the foregoing, the Day by which the Company shall make payment to Seller hereunder shall be increased by one (1) Day for each Day that Seller is delinquent in providing to the Company either: (i) the Monthly Report for the calendar month in question pursuant to Section 1 (Monthly Report) of Attachment T (Monthly Reporting and Dispute Resolution by Independent AF Evaluator) to this Agreement; or (ii) the information required under Section 2.16 (Seller's Preparation of the Monthly Invoice) of this Agreement. **[Drafting Note: If PPA has energy payment, replace language starting from subclause "(ii)" with the following: "(ii) the information required under Section 2.16 (Seller's Preparation of the Monthly Invoice) of this Agreement. However, if Company is not**

timely in providing data required in Section 2.15 (Company's Obligation to Provide Certain Data) and this directly causes Seller to be unable to deliver its invoice in accordance with the time frame set forth in Section 2.16 (Seller's Preparation of the Monthly Invoice), then Company shall still meet the payment date of the twentieth (20th) Business Day of the month following the month during which the invoice was submitted. If Seller is unable to provide a complete invoice for the reasons set forth in the preceding sentence, an estimated payment, subject to reconciliation with the complete invoice, may be made by Company as an interim provision until a complete invoice can be prepared by Seller and received by Company."]

- 2.18 Late Payments. Notwithstanding all or any portion of such invoice in dispute, and subject to the provisions of Section 2.12(a)(iii) of this Agreement (to the extent applicable), interest shall accrue on any invoiced amount that remains unpaid following the twentieth (20th) Business Day of each calendar month (or the last Business Day of that month if there are less than twenty Business Days in that month), or following the due date for such payment if extended pursuant to Section 2.17 (Payment Procedures), at the average daily Prime Rate for the period commencing on the Day following the Day such payment is due until the invoiced amounts (or amounts due to Seller if determined to be less than the invoiced amounts) are paid in full. Partial payments shall be applied first to outstanding interest and then to outstanding invoice amounts.
- 2.19 Adjustments to Invoices After Payment. In the event adjustments are required to correct inaccuracies in an invoice after payment, the Party requesting adjustment shall recompute and include in the Party's request the principal amounts due during the period of the inaccuracy together with the amount of interest from the date that such invoice was payable until the date that such recomputed amount is paid at the average daily Prime Rate for the period. The difference between the amount paid and that recomputed for the invoice, along with the allowable amount of interest, shall either be (i) paid to Seller or set-off by Company, as appropriate, in the next invoice payment to Seller, or (ii) objected to by the Party responsible for such payment within thirty (30) Days following its receipt of such request. If the Party responsible for such payment objects to the

request, then the Parties shall work together in good faith to resolve the objection. If the Parties are unable to resolve the objection, the matter shall, except to the extent otherwise provided in Section 28.3 (Exclusions), be resolved pursuant to Article 28 (Dispute Resolution). All claims for adjustments shall be waived for any amounts that were paid or should have been payable more than thirty-six (36) months preceding the date of receipt of any such request.

- 2.20 Company's Billing Records. Seller, after giving reasonable advance written notice to Company, shall have the right to review all billing, metering and related records necessary to verify the accuracy of payments relating to the Facility during Company's normal working hours on Business Days. Company shall maintain such records for a period of not less than thirty-six (36) months. **[Drafting Note: If PPA has energy payment, replace this section with the following:** Company's Billing Records. Seller, after giving reasonable advance written notice to Company, shall have the right to review all billing, metering and related records necessary to verify the accuracy of the data provided by Company pursuant to Section 2.15 (Company's Obligation to Provide Certain Data) and payments relating to the Facility during Company's normal working hours on Business Days. Company shall maintain such records for a period of not less than thirty-six (36) months.]

ARTICLE 3
FACILITY OWNED AND/OR OPERATED BY SELLER

- 3.1 The Facility. Seller agrees to furnish, install, operate, and maintain the Facility in accordance with the provisions of this Agreement, including, without limitation, the operating procedures and performance standards as more fully described in Attachment B (Facility Owned by Seller) and Attachment C (Methods and Formulas for Measuring Performance Standards). After the Commercial Operations Date, Seller agrees that no changes or additions to the Facility shall be made without prior written approval by Company and amendment to the Agreement unless such changes or additions to the Facility could not reasonably be expected to have a material effect on the assumptions used in performing the IRS.
- 3.2 Allowed Capacity. The net instantaneous MW output from the Facility may not exceed the Allowed Capacity. Company may take appropriate action to limit the Actual Output pursuant to, but not limited to, Article 8 (Company Dispatch), Article 9 (Personnel and System Safety), Article 25 (Good Engineering and Operating Practices), and Attachment B (Facility Owned by Seller). Company shall not be required to pay for any Actual Output of the Facility which exceeds the Allowed Capacity.
- 3.3 Point of Interconnection. The Point of Interconnection is shown on Attachment E (Single-Line Drawing and Interface Block Diagram), as provided in Section 1(a)(i) (Single-Line Drawing, Interface Block Diagram, Relay List, Relay Settings and Trip Scheme) of Attachment B (Facility Owned by Seller). The Point of Interconnection will be at the voltage level of the Company System. If it is necessary to step up the voltage at which Seller's electric energy is delivered to Company System, the Point of Interconnection will be on the high voltage side of the step-up transformer.
- 3.4 Renewable Portfolio Standards.
- (a) Renewable Portfolio Standards. If, as a result of any RPS Amendment, the electric energy delivered from the Facility should no longer qualify as "renewable electrical energy," Seller shall, at the request of Company, develop and recommend to Company within a reasonable period of time following Company's request, but in no event more than 90 Days after Seller's receipt of such request (or such other period of time as Company and Seller may agree in writing) reasonable measures to

cause the electric energy delivered from the Facility to come within such revised definition of "renewable electrical energy" ("Seller's RPS Modifications Proposal").

- (b) Seller's RPS Modifications Proposal. Upon receipt of Seller's RPS Modifications Proposal, Company will evaluate Seller's RPS Modifications Proposal. Seller shall assist Company in performing such evaluation as and to the extent reasonably requested by Company (including, but not limited to, providing such additional information as Company may reasonably request and participating in meetings with Company as Company may reasonably request).
- (c) RPS Modifications Document. If, following Company's evaluation of Seller's RPS Modifications Proposal, Company desires to consider the implementation by Seller of the changes recommended in Seller's RPS Modifications Proposal, Company shall provide Seller with written notice to that effect, such notice to be issued to Seller within 180 Days of receipt of Seller's RPS Modifications Proposal, and Company and Seller shall proceed to negotiate in good faith a document setting forth the specific changes to the Agreement that are necessary to implement such RPS Modifications Proposal (the "RPS Modifications Document"). A decision by Company to initiate negotiations with Seller as aforesaid shall not constitute an acceptance by Company of any of the details set forth in Seller's RPS Modifications Proposal, including but not limited to the RPS Modifications and the RPS Pricing Impact. Any adjustment to the Contract Pricing pursuant to such RPS Modifications Document shall be limited to the RPS Pricing Impact. The time periods set forth in such RPS Modifications Document as to the effective date for the RPS Modifications shall be measured from the date the PUC order with respect to such RPS Modifications becomes non-appealable as provided in Section 3.4(e) (PUC RPS Order).
- (d) Failure to Reach Agreement. If Company and Seller are unable to agree upon and execute a RPS Modifications Document within 180 Days of Company's written notice to Seller pursuant to Section 3.4(c) (RPS Modifications Document), Company shall have the option of declaring

the failure to reach agreement on and execute such Document to be a dispute and submit such dispute to an Independent Evaluator for the conduct of a determination pursuant to Section 3.4(h) (Dispute) of this Agreement. Any decision of the Independent Evaluator rendered as a result of such dispute shall include a form of a RPS Modifications Document as described in Section 3.4(c) (RPS Modifications Document).

- (e) PUC RPS Order. No RPS Modifications Document shall constitute an amendment to the Agreement unless and until a PUC order issued with respect to such document has become non-appealable ("PUC RPS Order"). Once the condition of the preceding sentence has been satisfied, such RPS Modifications Document shall constitute an amendment to this Agreement. To be "non-appealable" under this Section 3.4(e) (PUC RPS Order), such PUC RPS Order shall be either (i) not subject to appeal to any Circuit Court of the State of Hawai'i or the Supreme Court of the State of Hawai'i, because the thirty (30) Day period (accounting for weekends and holidays as appropriate) permitted for such an appeal has passed without the filing of notice of such an appeal, or (ii) affirmed on appeal to any Circuit Court of the State of Hawai'i or the Supreme Court, or the Intermediate Appellate Court upon assignment by the Supreme Court, of the State of Hawai'i, or affirmed upon further appeal or appellate process, and is not subject to further appeal, because the jurisdictional time permitted for such an appeal (and/or further appellate process such as a motion for reconsideration or an application for writ of certiorari) has passed without the filing of notice of such an appeal (or the filing for further appellate process).
- (f) Company's Rights. The rights granted to Company under Section 3.4(c) (RPS Modifications Document) and Section 3.4(d) (Failure to Reach Agreement) above are exclusive to Company. Seller shall not have a right to initiate negotiations of a RPS Modifications Document or to initiate dispute resolution under Section 3.4(h) (Dispute), as a result of a failure to agree upon and execute any RPS Modifications Document.
- (g) Limited Purpose. This Section 3.4 (Renewable Portfolio Standards) is intended to specifically address the

implementation of reasonable measures to cause the electric energy delivered from the Facility to come within the revised definition of "renewable electrical energy" under any RPS Amendment and is not intended for either Party to provide a means for renegotiating any other terms of this Agreement. Revisions to this Agreement in accordance with the provisions of this Section 3.4 (Renewable Portfolio Standards) are not intended to increase Seller's risk of non-performance or default.

- (h) Dispute. If Company decides to declare a dispute as a result of the failure to reach agreement and execute a RPS Modifications Document pursuant to Section 3.4(d) (Failure to Reach Agreement), it shall provide written notice to that effect to Seller. Within 20 Days of delivery of such notice Seller and Company shall agree upon an Independent Evaluator to resolve the dispute regarding a RPS Modifications Document. The Independent Evaluator shall be reasonably qualified and expert in renewable energy power generation, matters relating to the Performance Standards, financing, and power purchase agreements. If the Parties are unable to agree upon an Independent Evaluator within such 20-Day period, Company shall apply to the PUC for the appointment of an Independent Evaluator. If an Independent Observer retained under the Competitive Bidding Framework is qualified and willing and available to serve as Independent Evaluator, the PUC shall appoint one of the persons or entities qualified to serve as an Independent Observer to be the Independent Evaluator; if not, the PUC shall appoint another qualified person or entity to serve as Independent Evaluator. In its application, Company shall ask the PUC to appoint an Independent Evaluator within 30 Days of the application.
- (1) Promptly upon appointment, the Independent Evaluator shall request the Parties to address the following matters within the next 15 Days:
- (a) The reasonable measures required to be taken by Seller to cause the electric energy delivered from the Facility to come within such revised definition of "renewable electrical energy" under the RPS Amendment in question;

- (b) How Seller would implement such measures;
 - (c) Reasonably expected net costs and/or lost revenues associated with such measures so the energy delivered by the Facility complies with such revised definition of "renewable electrical energy" under the RPS Amendment in question;
 - (d) The appropriate level, if any, of RPS Pricing Impact in light of the foregoing; and
 - (e) Contractual consequences for non-performance that are commercially reasonable under the circumstances.
- (2) Within 90 Days of appointment, the Independent Evaluator shall render a decision unless the Independent Evaluator determines it needs to have additional time, not to exceed 45 Days, to render a decision.
- (3) The Parties shall assist the Independent Evaluator throughout the process of preparing its review, including making key personnel and records available to the Independent Evaluator, but neither Party shall be entitled to participate in any meetings with personnel of the other Party or review of the other Party's records. However, the Independent Evaluator will have the right to conduct meetings, hearings or oral arguments in which both Parties are represented. The Parties may meet with each other during the review process to explore means of resolving the matter on mutually acceptable terms.
- (4) The following standards shall be applied by the Independent Evaluator in rendering his or her decision: (i) if it is not technically or operationally feasible for Seller to implement reasonable measures required to cause the electric energy delivered from the Facility to come within such revised definition of "renewable electrical energy" under the RPS Amendment in question, the Independent Evaluator shall determine that the Agreement shall not be amended to comply with such changes in RPS (unless the Parties agree

otherwise); (ii) if it is technically or operationally feasible for Seller to implement reasonable measures required to cause the electric energy delivered from the Facility to come within such revised definition of "renewable electrical energy" under RPS, the Independent Evaluator shall incorporate such required changes into a RPS Modifications Document including (aa) Seller's RPS Modifications, (bb) pricing terms that incorporate the RPS Pricing Impact, and (cc) contract terms and conditions that are commercially reasonable under the circumstances, especially with respect to the consequences of non-performance by Seller as to the RPS Modifications. In addition to the RPS Modifications Document, the Independent Evaluator shall render a decision which sets forth the positions of the Parties and Independent Evaluator's rationale for his or her decisions on disputed issues.

- (5) The fees and costs of the Independent Evaluator shall be paid by Company up to the first \$30,000 of such fees and costs; above those amounts, the Party that is not the prevailing Party shall be responsible for any such fees and costs; provided, if neither Party is the prevailing Party, then the fees and costs of the Independent Evaluator above \$30,000, shall be borne equally by the Parties. The Independent Evaluator in rendering his or her decision shall also state which Party prevailed over the other Party, or that neither Party prevailed over the other.

ARTICLE 4
COMPANY-OWNED INTERCONNECTION FACILITIES

The terms and conditions related to the Company-Owned Interconnection Facilities are set forth in Attachment G (Company-Owned Interconnection Facilities) of this Agreement. In accordance with Section 8 (Transfer of Ownership/Title) of Attachment G (Company-Owned Interconnection Facilities), on the Transfer Date, Seller shall convey title to the Company-Owned Interconnection Facilities that were designed and constructed by or on behalf of Seller by executing a Bill of Sale and Assignment document substantially in the form set forth in Attachment H (Form of Bill of Sale and Assignment). In addition, in accordance with Section 8 (Transfer of Ownership/Title) of Attachment G (Company-Owned Interconnection Facilities) on the Transfer Date, Seller shall deliver to Company any and all executed documents required to assign all Land Rights necessary to operate and maintain the Company-Owned Interconnection Facilities on and after the Transfer Date to Company, which documents shall be substantially in the form set forth in Attachment I (Form of Assignment of Lease and Assumption).

ARTICLE 5
MAINTENANCE RECORDS AND SCHEDULING

5.1 Operating Records.

- (a) Seller's Logs. Seller shall maintain, at least daily, a log in which it shall record all pertinent data that will indicate whether the Facility is being operated in accordance with Good Engineering and Operating Practices. These data logs shall include, but not be limited to, all maintenance and inspection work performed at the Facility, circuit breaker trip operations, relay operations including target indications, megavar and megawatt recording charts (and/or equivalent computer records), all unusual conditions experienced or observed and any reduced capability and the reasons therefor and duration thereof. For each inverter, the data reported shall include planned derated hours, unplanned derated hours, average derated kW during the derated hours, scheduled maintenance hours, average derated kW during scheduled maintenance hours, hours on-control and hours on-line. Company shall have the right, upon reasonable notice and during regular Business Day hours to review and copy such data logs; provided, that if such logs reveal any inconsistency with Company's records, Company may request and review Seller's supporting records, correspondence, memoranda and other documents or electronically recorded data associated with such logs related to the operation and maintenance of the Facility in order to resolve such inconsistency.
- (b) Company Access to Seller's Logs. Seller shall provide Company access to Seller's records which identify the priority, as internally assigned by Seller, of specific preventive or corrective maintenance activities. These records shall include items for which Seller has deferred the inspection or corrective action to a future scheduled plant outage. In addition, Seller shall provide copies of applicable correspondence between Seller and its insurer(s) for the Facility equipment pertaining to Seller's maintenance practices and Seller's procedures and scheduling (including deferral) of maintenance at the Facility.

- (c) Time Period for Maintaining Records. Any and all records, correspondence, memoranda and other documents or electronically recorded data related to the operation and maintenance of the Facility shall be maintained by Seller for a period of not less than six (6) years.

5.2 Maintenance Records.

- (a) Seller's Summary of Maintenance and Inspection Performed. Prior to February 1 of each calendar year, Seller shall submit to Company for inspection at the Site, a summary in a format similar to the example provided in Attachment V (Summary of Maintenance and Inspection Performed in Prior Calendar Year) of all maintenance and inspection work performed in the prior calendar year, and of all conditions experienced or observed during such calendar year that may have a material adverse effect on or may materially impair the short-term or long-term operation of the Facility at the operational levels contemplated by this Agreement. The summary shall present the requested data in a meaningful and informative manner consistent with the cooperative exchange of information between the Parties. If available and practicable, such summary shall be provided in electronic format with sufficient software so that Company can group activities for specific process areas of the Facility and be able to view the maintenance history of a specific equipment item. Such summary shall also include Seller's proposals for correcting or preventing recurrences of identified equipment problems and for performing such other maintenance and inspection work as is required by Good Engineering and Operating Practices.
- (b) Company's Written Recommendations. Within sixty (60) Days of receiving such summary, and after any reasonable inspection desired by Company of the Facility and consultation with Seller, in the event there are issues identified that may have a material adverse effect on or may materially impair the short-term or long-term operation of the Facility at the operational levels contemplated by this Agreement, for purposes of addressing such issues, Company may provide written recommendations for specific operation or maintenance actions or for changes in the operation or maintenance program of the Facility. Company's making or failing to

make such recommendations shall not be construed as endorsing the operation and maintenance thereof or as any warranty of the safety, durability or reliability of the Facility nor as a waiver of any Company right. If Seller agrees with Company, Seller shall, within a reasonable time after Company makes such recommendations, not to exceed ninety (90) Days (or such longer period as reasonably agreed to by the Parties), implement Company's recommendations. If Seller disagrees with Company, it shall within ten (10) Days inform Company of alternatives it will take to accomplish the same intent, or provide Company with a reasonable explanation as to why no action is required by Good Engineering and Operating Practices. If Company disagrees with Seller's position, and if, for each of the three preceding Contract Years, the PV System Equivalent Availability Factor was less than **94%** and/or the MPR was less than the Tier 1 Bandwidth for such Contract Year, then the parties shall commission a study by a Qualified Independent Consultant selected from among the entities listed in Section 4(j) (Acceptable Person and Entities) of Attachment U (Calculation and Adjustment of Net Energy Potential) to this Agreement and the Qualified Independent Consultant will make a recommendation to remedy the situation. Seller shall abide by the Qualified Independent Consultant's recommendation contained in such study. Both Parties shall equally share in the cost for the Qualified Independent Consultant. However, Seller shall pay all costs associated with implementing the recommendation contained in the Independent Consultant's report. Notwithstanding the foregoing, Seller shall not be required to comply with any recommendations that, in Seller's reasonable judgment, will violate or void any warranties of equipment that is a part of, or used in connection with, the Facility or violate any long-term service agreement, or conflict with any written requirements, specifications or operating parameters of the manufacturer, with respect to such equipment, in which case Seller shall promptly notify Company thereof, and Seller and Company shall endeavor to reach a mutually satisfactory resolution of the matter in question.

5.3 Seller's Quarterly Maintenance Schedule. By each March 1st, June 1st, September 1st and December 1st (as applicable,

subsequent to the Commercial Operations Date), Seller shall provide to Company in writing a projection of maintenance outages and reductions in capacity for the next calendar quarter, including the estimated MW that is anticipated to be off-line for each projected maintenance event. Seller shall provide Company with prompt written notice of any deviation from its quarterly maintenance schedule, but in any case Seller shall provide such written notice not less than one (1) week prior to commencing any such rescheduled maintenance event. During any scheduled or rescheduled maintenance event, Seller shall provide updates to Company's operating personnel in the event there are any delays or changes to the proposed schedule, and shall promptly respond to any requests from Company for updates regarding the status of such maintenance event.

- 5.4 Seller's Annual Maintenance Schedule. In addition, Seller shall submit to Company a written schedule of maintenance outages which will reduce the capacity of the Facility by **[Drafting Note: the lower of five (5) MW or 25% of the Allowed Capacity]** or more for the next two-year period, beginning with January of the following year, in writing to Company each year by June 30. The schedule shall state the proposed dates and durations of scheduled maintenance, including the scope of work for the maintenance requiring shutdown or reduction in output of the Facility and the estimated MW that is anticipated to be off-line for each projected maintenance event. Company shall review the maintenance schedule for the two-year period and inform Seller in writing no later than December 1 of the same year of Company's concurrence or requested revisions; provided, however, that Seller shall not be required to agree to any proposed revisions that, in Seller's judgment, will void or violate any warranties of equipment that is part of, or used in connection with, the Facility or violate any long-term service agreement with respect to such equipment, in which case Seller shall promptly notify Company thereof, and Seller and Company shall endeavor to reach a mutually satisfactory resolution of the matter in question. With respect to such agreed upon revisions, Seller shall revise its schedule for timing and duration of scheduled shutdowns and scheduled reductions of output of the Facility to accommodate Company's revisions, unless such revisions would not be consistent with Good Engineering and Operating Practices, and make all commercially reasonable efforts, consistent with Good Engineering and Operating Practices, to

accommodate any subsequent changes in such schedule reasonably requested by Company.

- 5.5 Seller's Notification Obligations. When Seller learns that any of its equipment will be removed from or returned to service, and any such removal or return may affect the ability of the Facility to deliver electric energy to Company, Seller shall notify Company as soon as practicable. This requirement to notify shall include, but not be limited to, notice to Company of Seller's intention to shut down any solar photovoltaic generator plus inverter unit. Any unit shut-down shall be coordinated with Company in advance to the extent practicable to allow a reasonable amount of time for Company to make generation adjustments required by the loss of availability from a unit shut-down.
- 5.6 Operating and Maintenance Manuals. Not later than the Commercial Operation Date, Seller shall provide Company with (i) any and all manufacturer's equipment manuals and recommendations for maintenance and with any updates or supplements thereto within three (3) Business Days after Seller's receipt of same and (ii) a copy of the operating and maintenance manual and shall thereafter provide Company with any amendments thereto within three (3) Business Days after such amendment is adopted.

ARTICLE 6
FORECASTING

- 6.1 Data for Company Forecasts and Monitoring. Seller shall provide to Company the meteorological and production data and the Site description information required by Company in order for Company to (i) provide situational awareness to Company System Operator, (ii) monitor equipment availability and performance, (iii) produce a real-time forecast for operations as well as a Day-ahead forecast and hourly forecasts for all variable generation facilities on the Company System and (iv) monitor Seller's compliance with the Performance Standards set forth in Section 3 (Performance Standards) of the Attachment B (Facility Owned by Seller).
- 6.2 Monitoring and Communication Equipment. Seller shall install and maintain appropriate equipment (the "Monitoring and Communication Equipment") for the purposes of (i) measuring the meteorological and production data required under Section 6.1 (Data for Company Forecasts and Monitoring) with an accuracy of not less than that specified for each such data parameter in Section 8 (Data and Forecasting) of Attachment B (Facility Owned by Seller) and, if the monitoring equipment is part of the Company-Owned Interconnection Facilities, as set forth in Attachment G (Company-Owned Interconnection Facilities), and (ii) recording and transferring such data to Company in real time. Seller shall maintain at the Site sufficient replacement parts to avoid or otherwise minimize any shutdown of the Facility pursuant to Section 6.4 (Shutdown For Lack of Reliable Real Time Data) of this Agreement while any of the Monitoring and Communication Equipment is being repaired, replaced or re-calibrated.
- 6.3 Calibrations, Maintenance and Repairs.
- (a) Documentation Requirement. Seller shall provide to Company (i) the manufacturer's recommended schedule for the calibration and maintenance of each component of the Monitoring and Communication Equipment and (ii) subject to the limitation set forth in Section 1(a)(ii) (As-Builts) of Attachment B (Facility Owned by Seller) of this Agreement, documentation of the performance of all such calibration and maintenance per manufacturer specifications. Although Company is to receive from Seller the aforesaid recommended schedules for calibration and maintenance, as well documentation of

the performance of all such calibration and maintenance, Company shall have no responsibility to monitor Seller's compliance with such calibration and maintenance schedules. Accordingly, any failure by Company to bring Seller's attention any apparent failure by Seller to perform such recommended calibration and maintenance shall neither relieve Seller of its obligations under this Agreement to perform such calibration and maintenance nor constitute a waiver of Company's rights under this Agreement with respect to such failure in performance by Seller.

- (b) Corrective Measures. In the event of a pattern of material inconsistencies in the data stream provided by the Monitoring and Communication Equipment, Seller shall perform, at Seller's expense, such corrective measures as Company may reasonably require, such as the recalibration of all field measurement device components of the Monitoring and Communication Equipment.
- (c) Repairs. In the event of any failure in the Monitoring and Communication Equipment, Seller shall repair or replace such equipment within fifteen (15) Days of such failure, or within such longer period as may be reasonably agreed to by the Parties.

6.4 Shutdown For Lack of Reliable Real Time Data. Because the availability to the Company System Operator of reliable meteorological and production information in real time via SCADA is necessary in order for Company to effectively optimize the benefit of its right of Company Dispatch, Company shall have the right to direct Seller to shutdown the Facility due to the unavailability of such reliable real time meteorological and/or production data. In addition, in the event of the performance of corrective measures (including recalibration) and/or repairs to any Monitoring and Communication Equipment pursuant to Section 6.3(b) (Corrective Measures) or Section 6.3(c) (Repairs), Company shall have the right to direct Seller to shutdown the Facility and the Facility shall remain shutdown until such corrective action is completed. In the event the cause for any shutdown in this Section 6.4 (Shutdown For Lack of Reliable Real Time Data) falls within the definition of Seller-Attributable Non-Generation, such period of time shall be allocated as such for purposes of calculating the PV System Equivalent Availability Factor under Section 2.5(a)

(Calculation of PV System Equivalent Availability Factor) of this Agreement until such time as the successful completion of such corrective measures and/or repairs has been communicated by Seller to Company. If, after such communication, Company attempts to dispatch the Facility and determines that such corrective measures and/or repairs were not successfully completed, all time from the notice of successful completion to actual successful completion shall be revised as continuance of the deration or outage. Notwithstanding the foregoing, if Seller requests in writing for confirmation that the Facility's data is available to Company, then Company shall use reasonable efforts to respond to such request within three (3) Business Days in writing (with email being acceptable) confirming that either (1) the Facility's data is available to Company (at which point no additional time after such request shall count as Seller-Attributable Non-Generation), or (2) the Facility's data is not available so that Seller can take further appropriate corrective actions.

6.5 Seller Day-Ahead Forecasts of Actual Output.

- (a) Forecasts. Each Day during the Term commencing on the Commercial Operations Date, Seller shall submit to Company Seller's Day-ahead hourly forecasts of the Facility's Actual Output produced by a commercially available forecasting service or by the Seller's documented methodology (*i.e.*, climatology, persistence forecasting) for providing a forecast for the Facility's Actual Output for the next 24 hour period. Hourly Day-ahead forecasts shall be submitted to Company by 1200 Hawai'i Standard Time on each Day immediately preceding a Day on which electric energy from the Facility is to be delivered. Seller shall provide Company with an hourly forecast of Actual Output for each hour of the next Day. Seller shall update such forecast and provide unit availability updates any time information becomes available indicating a change in the forecast of Actual Output from the Facility. The forecasts called for by this Agreement shall be substantially in the form reasonably requested by Company.
- (b) Accuracy of Forecasts. Company acknowledges that the Seller's Day-ahead forecasts are based on forecast estimates and not guarantees. Such limitation

notwithstanding, Seller shall exercise commercially reasonable efforts to ensure the accuracy of the Day-ahead forecasts required hereunder for validation purposes and to support Company's forecasts. This includes a detailed description of the methodology used by Seller for forecasting. For example, Seller shall prepare such forecasts and updates by utilizing a solar power forecast or other service that is (i) commercially available or proprietary to Seller, (ii) comparable in accuracy to models or services commonly used in the solar energy industry and that reflect equipment availability, and (iii) is satisfactory to Company in the exercise of its reasonable discretion.

- (c) Company's Forecasting System. Company currently subscribes to a forecasting service. Seller, may, if it chooses, subscribe to the same forecasting service that Company does, at Seller's cost. If Seller so chooses to subscribe to such forecasting service and elects to use such service in lieu of creating its own forecast, Seller shall not be required to provide Day-ahead forecasts pursuant to this Section 6.5 (Seller Day-Ahead Forecasts of Actual Output). If Company changes its forecasting service and Seller elects not to subscribe to the same forecasting service, then the provisions of Section 6.5(a) (Forecasts) and Section 6.5(b) (Accuracy of Forecasts) shall apply.

- 6.6 Reports, Studies and Assessment. Prior to the Execution Date, Seller has provided Company with Seller's explanation of the methodology and underlying information used to derive the NEP RFP Projection, including the preliminary design of the Facility and the typical meteorological year file used to estimate the Renewable Resource Baseline. The independent consultant was selected from among the entities listed in Section 4(j) (Acceptable Person and Entities) of Attachment U (Calculation and Adjustment of Net Energy Potential) to this Agreement. Throughout the Term, Seller shall, for purposes of facilitating Company's forecasting, deliver to Company, promptly upon Seller's receipt of same, any reports, studies or assessments prepared for the benefit of the Seller by an independent engineer of (i) the electric energy producing potential of the Site or (ii) the Facility.

ARTICLE 7
SELLER PAYMENTS

Seller shall pay to Company (i) all amounts pursuant to Attachment G (Company-Owned Interconnection Facilities), (ii) all amounts pursuant to Section 10.1 (Meters) and Section 10.2 (Meter Testing), (iii) a monthly metering charge of \$25.00 per month, which is in addition to any charges due Company pursuant to the applicable rate schedule pursuant to Section 2.14 (Sales of Electric Energy By Company to Seller) of this Agreement and (iv) such other costs to be incurred by Company and reimbursed by Seller as set forth in this Agreement.

ARTICLE 8
COMPANY DISPATCH

- 8.1 General. Company shall have the right to dispatch all available real and reactive power delivered from the Facility to the Company System and to start up and shut down Seller's generating units, as it deems appropriate in its reasonable discretion, subject only to and consistent with Good Engineering and Operating Practices, the requirements set forth in Section 3 (Performance Standards) of Attachment B (Facility Owned by Seller) of this Agreement and Seller's maintenance schedule determined in accordance with Article 5 (Maintenance Records and Scheduling). Company shall not pay for reactive power.
- 8.2 Company Dispatch. Dispatch will either be by Seller's manual control under the direction of the Company System Operator or by remote computerized control by the EMS provided in Section 1(g) (Active Power Control Interface) of Attachment B (Facility Owned by Seller), in each case at Company's reasonable discretion. Notwithstanding anything to the contrary, the power produced by the Facility and/or stored in the BESS shall always be subject to dispatch by Company.
- 8.3 Company Rights of Dispatch. Company may require deration or outage in response to the Facility's failure to comply with Company Dispatch or to any conditions of Seller-Attributable Non-Generation. A deration or outage required by Company pursuant to the preceding sentence shall be considered "unplanned" and, until the conditions that led to the deration or outage are resolved by Seller and Seller notifies Company of the same, any such deration shall "count against" Seller for purposes of calculating the Measured Performance Ratio, and any such outage shall "count against" Seller for the purpose of calculating the PV System Equivalent Availability Factor. If, after such notification, Company attempts to dispatch the Facility and determines that such conditions that led to the deration or outage are not resolved, all time from the notice of resolution to actual resolution shall be revised as continuance of the deration or outage until the conditions that led to such outage or deration are resolved by Seller to Company's reasonable satisfaction. If Seller requests confirmation from Company that Seller's actions to resolve such conditions that led to the deration or outage were

successfully completed, then Company shall use reasonable efforts to respond to such request within three (3) Business Days in writing (with email being acceptable) to allow Seller the opportunity to take further appropriate corrective actions if needed. Nothing in this Section 8.3 (Company Rights of Dispatch) shall relieve Seller of its obligation under the terms of this Agreement to make available the full capability of the Facility for Company Dispatch.

8.4 Monthly Report. Commencing with the month during which the Commercial Operations Date is achieved, and for each calendar month thereafter during the Term, Seller shall prepare and provide to Company a Monthly Report by the tenth (10th) Business Day of the following month in accordance with Section 1 (Monthly Report) of Attachment T (Monthly Reporting and Dispute Resolution by Independent AF Evaluator) of this Agreement. Beginning with the Monthly Report for the last calendar month of the initial Contract Year, Seller shall include calculations of, as applicable, (a) the PV System Equivalent Availability Factor for the LD Period, (b) the Measured Performance Ratio for the MPR Assessment Period, (c) any of the BESS Capacity Ratio, the RTE Ratio, the BESS Annual Equivalent Availability Factor or the BESS Equivalent Forced Outage Factor for the BESS Measurement Period (if any), as well as (d) any liquidated damages to be assessed, as set forth in the form of Monthly Report set forth in Section 1 (Monthly Report) of said Attachment T (Monthly Reporting and Dispute Resolution by Independent AF Evaluator). The rights and obligations of the Parties with respect to each Monthly Report and any disagreements arising out of any Monthly Report are set forth in Section 1 (Monthly Report) and Section 2 (Monthly Report Disagreements) of Attachment T (Monthly Reporting and Dispute Resolution by Independent AF Evaluator) to this Agreement.

ARTICLE 9
PERSONNEL AND SYSTEM SAFETY

Notwithstanding any other provisions of this Agreement, if at any time Company reasonably determines that the Facility may endanger Company's personnel, and/or the continued operation of the Facility may endanger the integrity of the Company System or have an adverse effect on Company's other customers' electric service, Company shall have the right to disconnect the Facility from the Company System, as determined in the sole discretion of the Company System Operator. The Facility shall immediately comply with the dispatch instruction, which may be initiated through remote control, and shall remain disconnected (and in Seller-Attributable Non-Generation status if so determined), until such time as Company is satisfied that the condition(s) referred to above have been corrected. If Company disconnects the Facility from the Company System for personnel or system safety reasons, it shall as soon as practicable notify Seller by telephone, and thereafter make reasonable efforts to confirm, in writing (with email being acceptable), within three (3) Days of the disconnection, the reasons for the disconnection. If the reason for the disconnection constitutes Seller-Attributable Non-Generation, Company will notify Seller (1) whether the conditions resulting in such disconnection have been resolved (in which case no additional time after such confirmation shall count as Seller-Attributable Non-Generation); or (2) that conditions resulting in such disconnection have not been resolved so that Seller can take such appropriate corrective actions. Seller shall notify Company in writing when such corrective action has been completed; provided, however, that Seller shall remain in Seller-Attributable Non-Generation until Company is satisfied that the condition resulting in the disconnection has been corrected. Company shall use reasonable efforts to inspect such corrective measures (if necessary) and confirm the resolution of such condition within three (3) Business Days after Seller's notification.

ARTICLE 10
METERING

- 10.1 Meters. Company shall purchase, own, install and maintain the Revenue Metering Package suitable for measuring the export of electric energy from the Facility sold to Company in kilowatts and kilowatt-hours on a time-of-day basis and of reactive power flow in kilovars and true root mean square kilovar-hours. The metering point shall be as close as possible to the Point of Interconnection as allowed by Company. Seller shall make available a mutually agreeable location for the Revenue Metering Package. Seller shall install, own and maintain the infrastructure and other related equipment associated with the Revenue Metering Package, including but not limited to all enclosures (meter cabinets, meter pedestals, meter sockets, pull boxes, and junction boxes, along with their grounding/bonding connections), CT/PT mounting structures, conduits and ductlines, enclosure support structures, ground buses, pads, test switches, terminal blocks, isolation relays, telephone surge suppressors, and analog phone lines (one per meter), subject to Company's review and approval, as further described in Section 1(e) (Other Equipment) of Attachment B (Facility Owned by Seller). The Seller shall install this infrastructure such that it meets the requirements set forth in Chapter Six (IPP Metering) of the latest edition of the Company's Electric Service Installation Manual (ESIM). Company shall test such revenue meter prior to installation and shall test such revenue meter every fifth (5th) year. Seller shall reimburse Company for all reasonably incurred costs for the procurement, installation, maintenance (including maintenance replacements) and testing work associated with the Revenue Metering Package.
- 10.2 Meter Testing. Company shall provide at least twenty-four (24) hours' notice to Seller prior to any test it may perform on the revenue meters or metering equipment. Seller shall have the right to have a representative present during each such test. Seller may request, and Company shall perform, if requested, tests in addition to the every fifth-year test and Seller shall pay the cost of such tests. Company may, in its sole discretion, perform tests in addition to the fifth year test and Company shall pay the cost of such tests. If any of the revenue meters or metering equipment is found to be inaccurate at any time, as determined by testing in accordance with this Section 10.2

(Meter Testing), Company shall promptly cause such equipment to be made accurate, and the period of inaccuracy, as well as an estimate for correct meter readings, shall be determined in accordance with Section 10.3 (Corrections).

- 10.3 Corrections. If any test of revenue meters or metering equipment conducted by Company indicates that the revenue meter readings are in error by one percent (1%) or more, the revenue meters or meter readings shall be corrected as follows: (i) determine the error by testing the revenue meter at approximately ten percent (10%) of the rated current (test amperes) specified for such revenue meter; (ii) determine the error by testing the revenue meter at approximately one hundred percent (100%) of the rated current (test amperes) specified for the revenue meter; (iii) the average meter error shall then be computed as the sum of (aa) one-fifth (1/5) of the error determined in the foregoing clause "(i)" and (bb) four-fifths (4/5) of the error determined in the foregoing clause "(ii)". The average meter error shall be used to adjust the invoices in accordance with Section 2.19 (Adjustment to Invoices After Payment) for the amount of electric energy supplied to Company for the previous six (6) months from Facility, unless records of Company conclusively establish that such error existed for a greater or lesser period, in which case the correction shall cover such actual period of error.

ARTICLE 11

GOVERNMENTAL APPROVALS, LAND RIGHTS AND COMPLIANCE WITH LAWS

- 11.1 Governmental Approvals for Facility. Seller shall obtain, at its expense, any and all Governmental Approvals required for the construction, ownership, operation and maintenance of the Facility and the interconnection of the Facility to the Company System. Under no circumstance shall Seller commence any construction, operation or maintenance of the Facility or interconnection of the Facility to the Company System, without first obtaining the required, applicable Governmental Approvals.
- 11.2 Land Rights for Facility. Seller shall obtain, at its expense, any and all Land Rights required for the construction, ownership, operation and maintenance of the Facility on the Site and the interconnection of the Facility to the Company System. Seller shall provide to Company:
- (a) No later than the Execution Date, copies of the documents, recorded, if required by Company (including but not limited to any agreements with landowners) evidencing Seller's Land Rights establishing the right of Seller to construct, own, operate and maintain the Facility on the Site, whether by fee simple ownership of the Site, leasehold interest of the Site for a term at least as long as the Term of this Agreement or, in the alternative for actual fee simple or leasehold interest in the Site, a binding, executed letter of intent establishing the right of Seller to enter into a lease for the Site subject only to reasonable conditions related to PUC approval of this Agreement and such conditions that shall not affect the ability of the Seller to execute such lease.
 - (b) Within six (6) months of the Execution Date, Seller shall provide to Company a current survey (dated no earlier than the Execution Date) for the Site and any other property identified by Seller as requiring Land Rights. Within four (4) months of the Execution Date, Seller shall provide to Company (i) a preliminary title report (dated no earlier than the Execution Date) for the Site and any other property identified by Seller as requiring Land Rights, (ii) copies of all Land Rights already obtained, and (iii) a current list identifying

all Land Rights required for the construction, ownership, operation and maintenance of the Facility and the interconnection of the Facility to the Company System, including Seller's status as to whether such Land Rights have been obtained, have been negotiated or not yet pursued and if so, an estimated date when such Land Rights would be pursued;

- (c) Within three (3) months of Seller's identification of such additional necessary Land Rights, copies of such completed Land Rights, if any;

provided, however, that under no circumstance shall Seller commence any construction, operation or maintenance of the Facility or interconnection of the Facility to the Company System, or require or permit Company to commence any such construction, without Seller first obtaining the required, applicable Land Rights.

Seller shall bear complete responsibility for all delays in construction, operation and maintenance of the Facility or the interconnection of the Facility to the Company System resulting from Seller's failure to identify and/or timely obtain necessary Land Rights. In each case, such Land Rights documents may be redacted but only to the extent required to prevent disclosure of confidential or proprietary information of Seller or the counterparty to such agreement. Under no circumstances shall such redactions conceal information that is necessary for the Company to determine whether such documents establish the Land Rights of Seller to construct, own, operate and maintain the Facility on the Site and the interconnection of the Facility to the Company System in accordance with the terms of this Agreement.

- 11.3 Company-Owned Interconnection Facilities. If the Company-Owned Interconnection Facilities are to be constructed by Company, Seller shall, prior to commencement of construction thereof, provide the necessary Governmental Approvals and Land Rights for the construction, ownership, operation and maintenance of Company-Owned Interconnection Facilities. If the Company-Owned Interconnection Facilities are to be constructed by Seller, then Seller shall provide the necessary Governmental Approvals and Land Rights required for the commencement of construction and, prior to the start of each subsequent phase of construction, Seller shall provide the necessary and appropriate Governmental Approvals and Land Rights necessary for such related construction

activity. Regardless of whether Company or Seller constructs the Company-Owned Interconnection Facilities, Seller shall provide Company with an accounting of all necessary Governmental Approvals (in a list or spreadsheet) at the commencement of construction including relevant information regarding status and estimated completion. Seller shall update Company on the status of all necessary Governmental Approvals, including the addition of any new Governmental Approvals that may be discovered and required, in Seller's Monthly Progress Report submitted to Company. Notwithstanding the above, to the extent not already provided to Company, all required Governmental Approvals for the Company-Owned Interconnection Facilities shall be provided to Company on the Transfer Date in accordance Section 9 (Governmental Approvals for Company-Owned Interconnection Facilities) of Attachment G (Company-Owned Interconnection Facilities). Land Rights for Company-Owned Interconnection Facilities, whether provided at the commencement of construction if to be constructed by Company, or thereafter, if to be constructed by Seller, shall be obtained and its status updated by Seller to Company in accordance with Section 10 (Land Rights) of Attachment G (Company-Owned Interconnection Facilities). Notwithstanding the above, under no circumstance shall Seller commence any construction, operation or maintenance of the Company-Owned Interconnection Facilities, or require or permit Company to commence any such construction, without first obtaining the required, applicable Governmental Approvals and Land Rights. Seller shall bear complete responsibility for all delays in construction, operation and maintenance of the Company-Owned Interconnection Facilities resulting from Seller's failure to identify and/or timely obtain necessary Governmental Approvals and Land Rights for such Company-Owned Interconnection Facilities.

- 11.4 Compliance With Laws. Seller shall at all times comply with all applicable Laws and shall be responsible for all costs and expenses associated therewith.

ARTICLE 12
TERM OF AGREEMENT AND COMPANY'S
OPTION TO PURCHASE AT END OF TERM

- 12.1 Term. Subject to Section 12.2 (Effectiveness of Obligations) of this Agreement, the initial term of this Agreement shall commence upon the Execution Date of this Agreement and, unless terminated sooner as provided in this Agreement, shall remain in effect for [twenty **(20)** Contract Years] following the Commercial Operations Date (the "Initial Term"). This Agreement shall automatically terminate upon expiration of the Initial Term. If the Parties desire, the Parties may negotiate terms and conditions of an extension term ("Extended Term"), including reduced Contract Pricing in recognition that Seller will have recovered its capital and financing costs, which terms and conditions (i) shall be submitted to the PUC by Company for approval no later than one (1) year prior to the expiration of the Initial Term and (ii) shall have no effect without PUC approval.
- 12.2 Effectiveness of Obligations. Only Article 3 (Facility Owned and/or Operated by Seller), Article 12 (Term of Agreement and Company's Option to Purchase at End of Term), Article 14 (Credit Assurance and Security) as it relates to Development Period Security, Article 17 (Indemnification), Article 19 (Transfers, Assignments, and Facility Debt), Article 22 (Warranties and Representations), Article 24 (Financial Compliance), Article 28 (Dispute Resolution), Article 29 (Miscellaneous), Section 3 (Seller Payment To Company for Company-Owned Interconnection Facilities and Review Of Facility) of Attachment G (Company-Owned Interconnection Facilities) and the Defined Terms of this Agreement shall become effective on the Execution Date. Except where obligations of the Parties are explicitly stated as being effective before the Effective Date, all other portions of this Agreement shall become effective on the Effective Date.
- 12.3 PUC Approval.
- (a) This Agreement is subject to approval by the PUC in the form of a satisfactory PUC Approval Order and the Parties' respective obligations hereunder are conditioned upon receipt of such approval, except as specifically provided otherwise herein. Upon the

Execution Date of this Agreement, the Parties shall use good faith efforts to obtain, as soon as practicable, a PUC Approval Order that satisfies the requirements of Section 29.20(a) (PUC Approval Order). Company shall submit to the PUC an application for a satisfactory PUC Approval Order but does not extend any assurances that a PUC Approval will ultimately be obtained. Seller will provide reasonable cooperation to expedite obtaining a PUC Approval Order including timely providing information requested by Company to support its application, including information for Company and its consultant to conduct a greenhouse gas emissions analysis for the PUC application, as well as information requested by the PUC and parties to the PUC proceeding in which approval is being sought. Seller understands that lack of cooperation may result in Company's inability to file an application with the PUC and/or a failure to receive a PUC Approval Order. For the avoidance of doubt, Company has no obligation to seek reconsideration, appeal, or other administrative or judicial review of any Unfavorable PUC Order. The Parties agree that neither Party has control over whether or not a PUC Approval Order will be issued and each Party hereby assumes any and all risks arising from, or relating in any way to, the inability to obtain a satisfactory PUC Approval Order and hereby releases the other Party from any and all claims relating thereto.

- (b) Seller shall seek participation without intervention in the PUC docket for approval of this Agreement pursuant to applicable rules and orders of the PUC. The scope of Seller's participation shall be determined by the PUC. However, Seller expressly agrees to seek participation for the limited purpose and only to the extent necessary to assist the PUC in making an informed decision regarding the approval of this Agreement. If the Seller chooses not to seek participation in the docket, then Seller expressly agrees and knowingly waives any right to claim, before the PUC, in any court, arbitration or other proceeding, that the information submitted and the arguments offered by Company in support of the application requesting the PUC Approval Order are insufficient to meet Company's burden of justifying that the terms of this Agreement are just and reasonable and in the public interest, or otherwise

deficient in any manner for purposes of supporting the PUC's approval of this Agreement. Seller shall not seek in the docket and Company shall not disclose any confidential information to Seller that would provide Seller with an unfair business advantage or would otherwise harm the position of others with respect to their ability to compete on equal and fair terms.

12.4 Interconnection Requirements Study. If this Agreement is executed prior to completion of the Interconnection Requirements Study, then following the completion of the IRS:

- (a) The Parties shall, no later than the PPA Amendment Deadline, execute a formal amendment to this Agreement substituting new versions of Attachment B (Facility Owned by Seller), Attachment E (Single-Line Drawing and Interface Block Diagram), Attachment F (Relay List and Trip Scheme), Attachment G (Company-Owned Interconnection Facilities), Attachment K (Guaranteed Project Milestones), Attachment K-1 (Seller's Conditions Precedent and Company Milestones) and Attachment L (Reporting Milestones) (the "Interconnection Requirements Amendment") to reflect the results of the IRS. If the Interconnection Requirements Amendment is not executed by the PPA Amendment Deadline, either Party may, by written notice delivered to the other Party, declare the Agreement null and void; or
- (b) If Seller is dissatisfied with the results of the IRS, Seller shall have the option, by written notice delivered to Company no later than the Termination Deadline, to declare this Agreement null and void. Failure of Seller to declare this Agreement null and void pursuant to the preceding sentence shall not obligate Seller to execute the Interconnection Requirements Amendment.

12.5 Prior to Effective Date. Company may, by written notice delivered prior to the Effective Date, declare the Agreement null and void if any one or more of the following conditions applies:

- (a) Seller implements a material change to the Facility without following the requirements of Section 5(f) of Attachment A (Description of Generation, Conversion and Storage Facility).

- (b) Seller is in material breach of any of its representations, warranties and covenants under the Agreement, including, but not limited to, (i) the provisions of Section 22.2(c) and Section 22.2(d) requiring Seller to have all Land Rights and Governmental Approvals as provided therein; and (ii) the provisions of Section 3(b)(ii) (Company-Owned Interconnection Facilities Prepayment) of Attachment G (Company-Owned Interconnection Facilities) requiring the payment by Seller to Company of the amounts specified within the time periods provided therein.
- (c) Seller, subsequent to making the payment to Company required under Section 3(b)(ii) (Company-Owned Interconnection Facilities Prepayment) of Attachment G (Company-Owned Interconnection Facilities), or subsequent to making the payment to Company to pay for the IRS, requests in writing that Company stop or otherwise delay the performance of the work for which Company received such payment.
- (d) Any of the IRS Letter Agreements are terminated pursuant to the terms thereof prior to the completion of the Interconnection Requirements Study.

12.6 Time Periods for PUC Submittal Date and PUC Approval.

- (a) Time Period for PUC Submittal Date. If the PUC Submittal Date has not occurred within 120 Days of the Execution Date, or such longer period as Company and Seller may agree to by a subsequent written agreement, Company may, by written notice delivered within thirty (30) Days of the expiration of such period, declare the Agreement null and void if the reason the application has not been filed is (i) any one or more of the conditions set forth in Section 12.5 (Prior to Effective Date) or (ii) Seller's failure to provide in a timely manner information reasonably requested by Company to support such application.
- (b) Time Period for PUC Approval. If the Commission issues an Unfavorable PUC Order or if a PUC Approval Order is not issued within twelve (12) months of the PUC Submittal Date, or within such longer period as Company and Seller may agree to by a written agreement ("PUC Approval Time Period"), then Company or Seller may, by written notice delivered within one hundred and eighty

(180) Days of (i) in the case that an Unfavorable PUC Order has been issued, the date the Unfavorable PUC Order becomes non-appealable or (ii) in the case that a PUC Approval Order is not issued within twelve (12) months of the PUC Submittal Date, or the expiration of the PUC Approval Time Period, as applicable, declare this Agreement null and void. If a PUC Approval Order or an Unfavorable PUC Order is issued within the PUC Approval Time Period but that order is appealed, and a Non-appealable PUC Approval Order is not obtained within twenty-four (24) months of the PUC Submittal Date, or within such longer period as Company and Seller may agree to by a subsequent written agreement (the "PUC Order Appeal Period"), then Company or Seller may, by written notice delivered within ninety (90) Days after the expiration of the PUC Order Appeal Period, declare this Agreement null and void.

12.7 Agreement Null and Void. If the Agreement is declared null and void pursuant to Section 12.4 (Interconnection Requirements Study), Section 12.5 (Prior to Effective Date), Section 12.6 (Time Periods for PUC Submittal Date and PUC Approval), or Section 1(d) (NEP IE Estimate, Liquidated Damages and Seller's Null and Void Right) of said Attachment U (Calculation and Adjustment of Net Energy Potential), the Parties hereto shall thereafter be free of all obligations hereunder except as set forth in this Section 12.7 (Agreement Null and Void) and Section 14.3 (Return of Development Period Security), and shall pursue no further remedies against one another; provided, however, that if in response to Seller's request and Seller's offer of adequate assurance of reimbursement, Company agrees in writing to incur costs associated with Company-Owned Interconnection Facilities prior to the Non-appealable PUC Approval Order Date or completion of the IRS, Seller shall pay Company the actual costs and cost obligations incurred by Company as of the date the Agreement is declared null and void for Company-Owned Interconnection Facilities and any reasonable costs incurred thereafter and Company shall refund to Seller any amounts advanced by Seller in excess of such costs. A declaration that this Agreement is null and void pursuant to Section 12.4 (Interconnection Requirements Study), Section 12.5 (Prior to Effective Date), Section 12.6 (Time Periods for PUC Submittal Date and PUC Approval), or Section 1(d) (NEP IE Estimate, Liquidated Damages and Seller's Null and Void Right) of said Attachment U (Calculation and Adjustment

of Net Energy Potential), shall not affect the following provisions, which shall remain in full force and effect: Section 12.2 (Effectiveness of Obligations), this Section 12.7 (Agreement Null and Void), Section 24.2 (Confidentiality), Article 28 (Dispute Resolution), Section 29.3 (Notices), Section 29.8 (Governing Law, Jurisdiction and Venue), Section 29.14 (Settlement of Disputes), Section 29.19 (Computation of Time), Section 29.23 (No Third Party Beneficiaries), Section 29.24 (Hawai'i General Excise Tax), and Section 7 (Land Restoration) of Attachment G (Company-Owned Interconnection Facilities).

- 12.8 Termination Rights. Notwithstanding any of the foregoing, the right of Company or Seller to terminate the Agreement at any time upon the occurrence of any Event of Default described in Article 15 (Events of Default) shall remain in full force and effect.
- 12.9 Option to Purchase Facility and Right of First Negotiation. Company shall have the right of first negotiation prior to the end of the Term and option to purchase the Facility at the end of the Term, as provided in Attachment P (Sale of Facility by Seller) to this Agreement.

ARTICLE 13
GUARANTEED PROJECT MILESTONES
INCLUDING COMMERCIAL OPERATIONS

[COMPANY TO DECIDE, FOLLOWING COMPLETION OF IRS, IF ANY GUARANTEED PROJECT MILESTONES ARE NECESSARY IN ADDITION TO THOSE LISTED IN ATTACHMENT K AND, IF SO, WHAT ARE THE CONSEQUENCES OF MISSING SUCH OTHER GUARANTEED PROJECT MILESTONES.]

- 13.1 Time is of the Essence. Time is of the essence of this Agreement, and Seller's ability to achieve the Construction Milestones is critically important.
- 13.2 Failure to Meet Reporting Milestones. If Seller does not meet a Reporting Milestone, in each case as set forth in Attachment L (Reporting Milestones), Seller shall submit to Company, within ten (10) Business Days of any such missed Reporting Milestone, a remedial action plan which shall provide a detailed description of Seller's course of action and plan to achieve (i) the missed Reporting Milestone date within ninety (90) Days of the missed Reporting Milestone and (ii) all subsequent Construction Milestones, provided that delivery of any remedial action plan shall not relieve Seller of its obligation to meet any subsequent Construction Milestones.
- 13.3 Guaranteed Project and Reporting Milestone Dates. Seller shall achieve each Guaranteed Project Milestone Date or Reporting Milestone Date, subject (to the extent applicable) to the following extensions:
- (a) if the PUC Approval Order Date occurs more than one hundred eighty (180) Days after the Execution Date, Seller and Company shall be entitled to an extension of the Guaranteed Project Milestone Dates, Reporting Milestone Dates equal to the number of Days that elapse between the end of the aforesaid 180-Day period and the PUC Approval Order Date; provided, that in no event will the Guaranteed Commercial Operations Date be extended beyond [REDACTED] **[Note - outside date to be inserted based on type of proposal];** or
 - (b) if the failure to achieve a Construction Milestone by the applicable Guaranteed Project Milestone Date or Reporting Milestone Date is the result of Force Majeure (which, for purposes of this Section 13.3(b) excludes any delay in obtaining the PUC Approval Order because

that contingency is addressed in Section 13.3(a) above), and if and so long as the conditions set forth in Section 21.4 (Satisfaction of Certain Conditions) are satisfied, such Guaranteed Project Milestone Date or Reporting Milestone Date shall be extended by a period equal to the lesser of three hundred sixty-five (365) Days or the duration of the delay caused by the Force Majeure; or

- (c) if the failure to achieve a Guaranteed Project Milestone by the applicable Guaranteed Project Milestone Date is the result of any failure by Company in the timely performance of its obligations under this Agreement, including achievement of its Company Milestones by the Company Milestone Dates as set forth on Attachment K-1 (Seller's Conditions Precedent and Company Milestones), as such dates may be extended in accordance with Section 13.3 (Guaranteed Project and Reporting Milestone Dates) and Section 13.8 (Company Milestones), Seller shall, provided Seller has satisfied the Seller's Conditions Precedent set forth in Attachment K-1 (Seller's Conditions Precedent and Company Milestones) by the respective Seller's Conditions Precedent Date set forth in said Attachment K-1, be entitled to an extension of such Guaranteed Project Milestone Date equal to the duration of the period of delay directly caused by such failure in Company's timely performance. Such extension on the terms described above shall be Seller's sole remedy for any such failure by Company. For purposes of this Section 13.3(c), Company's performance will be deemed to be "timely" if it is accomplished within the time period specified in this Agreement with respect to such performance or, if no time period is specified, within a reasonable period of time. If the performance in question is Company's review of plans, the determination of what is a "reasonable period of time" will take into account Company's past practices in reviewing and commenting on plans for similar facilities.

13.4 Damages and Termination.

(a) Daily Delay Damages.

- (1) If a Guaranteed Project Milestone (other than Commercial Operations) has not been achieved by the

applicable Guaranteed Project Milestone Date as extended as provided in Section 13.3 (Guaranteed Project and Reporting Milestone Dates), Company shall collect and Seller shall pay liquidated damages in the amount of \$ [REDACTED] for each Day ("Daily Delay Damages") following the applicable Guaranteed Project Milestone Date, as extended in accordance with Section 13.3 (Guaranteed Project and Reporting Milestone Dates); provided, however, that the number of Days for which Company shall collect and Seller shall pay Daily Delay Damages for a failure to achieve a Guaranteed Project Milestone by the Guaranteed Project Milestone Date shall not exceed sixty (60) Days for each such missed Guaranteed Project Milestone Date (the "Construction Delay LD Period"). **[Note: Contract Capacity x \$50/kW ÷ 180 Days = Daily Delay Damages.]**

- (2) If the Commercial Operations Date has not been achieved by the Guaranteed Commercial Operations Date as extended as provided in Section 13.3 (Guaranteed Project and Reporting Milestone Dates), in addition to any Daily Delay Damages collected pursuant to Section 13.4(a)(1), Company shall collect and Seller shall pay Daily Delay Damages following the Guaranteed Commercial Operations Date, as such date may be extended in accordance with Section 13.3 (Guaranteed Project and Reporting Milestone Dates), provided that the number of Days for which Company shall collect and Seller shall pay Daily Delay Damages for failing to achieve the Guaranteed Commercial Operations Date shall not exceed one hundred eighty (180) Days (the "COD Delay LD Period").

- (b) Termination and Termination Damages for Failure to Achieve a Guaranteed Project Milestone Date. If, upon the expiration of the Construction Delay LD Period or the COD Delay LD Period, as applicable, Seller has not achieved the applicable Guaranteed Project Milestone, Company shall have the right, notwithstanding any other provision of this Agreement to the contrary, to terminate this Agreement with immediate effect by issuing a written termination notice to Seller designating the Day such termination is to be effective,

provided that Company shall issue such notice no later than thirty (30) Days following the expiration of the Construction Delay LD Period or the COD Delay LD Period, as applicable. The effective date of such termination shall be not later than the date that is thirty (30) Days after such notice is deemed to be received by Seller, and not earlier than the later to occur of the Day such notice is deemed to be received by Seller or the Day following the expiration of the Construction Delay LD Period or the COD Delay LD Period, as applicable. If the Agreement is terminated by Company pursuant to this Section 13.4 (Damages and Termination), Company shall have the right to collect Termination Damages, which shall be calculated in accordance with Article 16 (Damages in the Event of Termination by Company) of this Agreement.

- 13.5 Payment of Daily Delay Damages. Company shall draw upon the Development Period Security on a monthly basis for payment of the total Daily Delay Damages incurred by Seller during the preceding calendar month. If the Development Period Security is at any time insufficient to pay the amount of the draw to which Company is then entitled, Seller shall pay any such deficiency to Company promptly upon demand.
- 13.6 Liquidated Damages Appropriate. Seller's inability to achieve Commercial Operations by the Guaranteed Commercial Operations Date may cause Company to not meet applicable RPS requirements and require Company to devote substantial additional resources for administration and oversight activities. As such, Company may incur financial consequences for failure to meet such requirements. Consequently, each Party agrees and acknowledges that (i) the damages that Company would incur due to delay in achieving Commercial Operations by the Guaranteed Commercial Operations Date (subject to the extensions provided in Section 13.3 (Guaranteed Project and Reporting Milestone Dates)) would be difficult or impossible to calculate with certainty, (ii) the Daily Delay Damages set forth in Section 13.4 (Damages and Termination) are an appropriate approximation of such damages and (iii) the Daily Delay Damages are the sole and exclusive remedies for Seller's failure to achieve Commercial Operations by the Guaranteed Commercial Operations Date.

- 13.7 Monthly Progress Reports. Commencing upon the Execution Date of this Agreement, Seller shall submit to Company, on the tenth (10th) Business Day of each calendar month until the Commercial Operations Date is achieved, a progress report for the prior month in a form set forth on Attachment S (Form of Monthly Progress Report) (the "Monthly Progress Report"). These progress reports shall notify Company of the current status of each Construction Milestone. Seller shall include in such report a list of all letters, notices, applications, filings and Governmental Approvals sent to or received from any Governmental Authority and shall provide any such documents as may be reasonably requested by Company. In addition, Seller shall advise Company as soon as reasonably practicable of any problems or issues of which it is aware which may materially impact its ability to meet the Construction Milestones. Seller shall provide Company with any requested documentation to support the achievement of Construction Milestones within ten (10) Business Days of receipt of such request from Company. Upon the occurrence of a Force Majeure, Seller shall also comply with the requirements of Section 21.4 (Satisfaction of Certain Conditions) to the extent such requirements provide for communications to Company beyond those required under this Section 13.7 (Monthly Progress Reports).
- 13.8 Company Milestones. Company's obligation to achieve the Company Milestones is contingent upon Seller completing the Seller's Conditions Precedent set forth in Attachment K-1 (Company Milestones and Seller's Conditions Precedent). Company shall achieve each of the Company Milestones by the date set forth for such Company Milestones in Attachment K-1 (Seller's Conditions Precedent and Company Milestones) of this Agreement (each such date, a "Company Milestone Date"), as such date may be extended in accordance with Section 13.3 (Guaranteed Project and Reporting Milestone Dates) and this Section 13.8 (Company Milestones); provided, however in the event Seller does not complete a Seller's Condition Precedent on or before the applicable date set forth in Attachment K-1 (Seller's Conditions Precedent and Company Milestones), subject to the extensions set forth in Section 13.3 (Guaranteed Project and Reporting Milestone Dates), Company shall be entitled to an extension as follows: (i) for the commencement of Acceptance Testing, the new Company Milestone Date shall be as set forth in clause "(gg)" of Section 2(f)(i) of Attachment G (Company-Owned Interconnection Facilities); and (ii) for any other Company

Milestone Date, the extension shall be for the period of time reasonably necessary to meet any such Company Milestone Date adversely affected by Seller's failure but no shorter than a day-for-day extension.

ARTICLE 14
CREDIT ASSURANCE AND SECURITY

- 14.1 General. Seller is required to post and maintain Development Period Security and Operating Period Security based on the requirements of this Article 14 (Credit Assurance and Security).
- 14.2 Development Period Security. To guarantee undertaking the performance of Seller's obligations under the Agreement for the period prior to the Commercial Operations Date (including but not limited to Seller's obligation to meet the Guaranteed Commercial Operations Date), Seller shall provide 50% of the Development Period Security to Company within ten (10) Days of Execution Date of the Agreement and the remaining 50% of the Development Period Security within ten (10) Business Days of the execution of the Interconnection Requirements Amendment.
- 14.3 Return of Development Period Security. The Development Period Security shall be returned to Seller, subject to Company's right to draw from the Development Period Security as set forth in Section 14.7 (Company's Right to Draw from Security Funds), in the following circumstances: (i) this Agreement is declared null and void pursuant to any of Section 12.4 (Interconnection Requirements Study), Section 12.5 (Prior to Effective Date), Section 12.6 (Time Periods for PUC Submittal Date and PUC Approval) or Section 1(d) (NEP IE Estimate, Liquidated Damages and Seller's Null and Void Right) of said Attachment U (Calculation and Adjustment of Net Energy Potential); (ii) the PUC issues an order denying approval for an application for a PUC Approval Order, which does not become subject to appeal; (iii) the PUC issues an Unfavorable PUC Order, which does not become subject to appeal; (iv) a Non-Appealable PUC Approval Order is not obtained within the time periods specified in Section 12.6(b) (Time Period for PUC Approval); or (v) following Company's receipt of Operating Period Security pursuant to Section 14.4 (Operating Period Security) of this Agreement.
- 14.4 Operating Period Security. To guarantee the performance of Seller's obligations under the Agreement for the period starting from the Commercial Operations Date to the expiration or termination of this Agreement, Seller shall provide satisfactory operating period security to Company in the amount of \$75/kW based on the Contract Capacity (the

"Operating Period Security"). Seller shall provide such Operating Period Security to Company within five (5) Business Days after the Commercial Operations Date, provided that, at all times, some form of Security Funds shall be in place and available to Company, whether Development Period Security or Operating Period Security.

- 14.5 Form of Security. Seller shall supply the Development Period and Operating Period Security required in the form of an irrevocable standby letter of credit with no documentation requirement substantially in the form attached to this Agreement as Attachment M (Form of Letter of Credit) from a bank chartered in the United States with a credit rating of "A-" or better. If the rating (as measured by Standard & Poor's) of the bank issuing the standby letter of credit falls below A-, Company may require Seller to replace, within thirty (30) Days' notice by Company, the standby letter of credit with a standby letter of credit from another bank chartered in the United States with a credit rating of "A-" or better. Such letter of credit shall be issued for a minimum term of one (1) year. Furthermore, at the end of each year the security shall be renewed for an additional one (1) year term so that at the time of such renewal, the remaining term of any such security shall not be less than one (1) year. The letter of credit shall include a provision for at least thirty (30) Days advance notice to Company and Seller of any expiration or earlier termination of the letter of credit so as to allow Company sufficient time to exercise its rights under said security if Seller fails to extend or replace the security. In all cases, the reasonable costs and expenses of establishing, renewing, substituting, canceling, increasing, reducing, or otherwise administering the letter of credit shall be borne by Seller. In the event Company receives notice from the issuing bank that a letter of credit for the Development Period Security or Operating Period Security will be cancelled or is set to expire and will not be extended, Company shall endeavor, but shall not be obligated, to provide Seller with notice of such cancellation or termination. Company shall not be responsible for any lack of notice to Seller of such letter of credit's cancellation or termination and the events resulting therefrom, provided, however, that if Company draws upon the then full amount remaining under the letter of credit, the provisions of Section 14.8 (Failure to Renew or Extend Letter of Credit) and Section 14.9 (L/C Proceeds

Escrow) shall apply. In the event the letter of credit for Development Period Security or Operating Period Security ever expires or is terminated without Company drawing on such full amount remaining under the letter of credit prior to its expiration, and Seller has not been afforded the opportunity to replace the letter of credit prior to its expiration or termination because of lack of notice, Seller shall be provided a grace period of five (5) Business Days from any notice of such expiration or termination of the letter of credit to obtain and provide to Company a substitute letter of credit meeting the requirements of this Article 14 (Credit Assurance and Security).

- 14.6 Security Funds. The Development Period Security and Operating Period Security, including L/C Proceeds therefrom (collectively referred to as the "Security Funds") established, funded, and maintained by Seller pursuant to the provisions of this Article 14 (Credit Assurance and Security) shall provide security for the performance of Seller's obligations under this Agreement and shall be available to be drawn on by Company as provided in Section 14.7 (Company's Right to Draw from Security Funds). Seller shall maintain the Security Funds at the contractually-required level throughout the Term of this Agreement. Seller shall replenish the Security Funds to such required level within fifteen (15) Business Days after any draw on the Security Funds by Company or any reduction in the value of Security Funds below the required level for any other reason. Notwithstanding the foregoing, Seller's obligation to replenish the Development Period Security shall not exceed in total three (3) times the original amount of the Development Period Security required under Section 14.2 (Development Period Security) of this Agreement.
- 14.7 Company's Right to Draw from Security Funds. In addition to any other remedy available to it, Company may, before or after termination of this Agreement, draw from the Security Funds such amounts as are necessary to recover amounts Company is owed pursuant to this Agreement or the IRS Letter Agreements, including, without limitation, any damages due Company, any interconnection costs owed pursuant to Attachment G (Company-Owned Interconnection Facilities) and any amounts for which Company is entitled to indemnification under this Agreement. Company may, in its sole discretion, draw all or any part of such amounts due Company from any of the Security Funds to the extent available pursuant to this

Article 14 (Credit Assurance and Security), and from all such forms, and in any sequence Company may select. Any failure to draw upon the Security Funds or other security for any damages or other amounts due Company shall not prejudice Company's rights to recover such damages or amounts in any other manner.

14.8 Failure to Renew or Extend Letter of Credit. If the letter of credit is not renewed or extended at least thirty (30) Days prior to its expiration or earlier termination, Company shall have the right to draw immediately upon the full amount of the letter of credit and to place the proceeds of such draw (the "L/C Proceeds"), at Seller's cost, in an escrow account in accordance with Section 14.9 (L/C Proceeds Escrow), until and unless Seller provides a substitute letter of credit meeting the requirements of this Article 14 (Credit Assurance and Security).

14.9 L/C Proceeds Escrow. If Company draws on the letter of credit pursuant to Section 14.8 (Failure to Renew or Extend Letter of Credit), and so long as a substitute letter of credit meeting the requirements of this Article 14 (Credit Assurance and Security) is not obtained and provided to Company, Company shall, in order to avoid comingling the L/C Proceeds, have the right but not the obligation to place the L/C Proceeds in an escrow account as provided in this Section 14.9 (L/C Proceeds Escrow) with a reputable escrow agent acceptable to Company ("Escrow Agent"). Without limitation to the generality of the foregoing, a federally-insured bank shall be deemed to be a "reputable escrow agent." Company shall have the right to apply the L/C Proceeds as necessary to recover amounts Company is owed pursuant to this Agreement or the IRS Letter Agreements, including, without limitation, any damages due Company, any interconnection costs owed pursuant to Attachment G (Company-Owned Interconnection Facilities) and any amounts for which Company is entitled to indemnification under this Agreement. To that end, the documentation governing such escrow account shall be in form and content satisfactory to Company and shall give Company the sole authority to draw from the account. Seller shall not be a party to such documentation and shall have no rights to the L/C Proceeds. Upon full satisfaction of Seller's obligations under this Agreement, including recovery by Company of amounts owed to it under this Agreement, Company shall instruct the Escrow Agent to remit to the bank that issued the letter of credit

that was the source of the L/C Proceeds the remaining balance (if any) of the L/C Proceeds. If there is more than one escrow account with L/C Proceeds, Company may, in its sole discretion, draw on such accounts in any sequence Company may select. Any failure to draw upon the L/C Proceeds for any damages or other amounts due Company shall not prejudice Company's rights to recover such damages or amounts in any other manner. If a substitute letter of credit satisfying the requirements of this Article 14 (Credit Assurance and Security) is obtained and provided to Company, the net L/C Proceeds remaining as of the date that such substitute letter of credit is provided, shall be returned to Seller, or as Seller directs in writing.

- 14.10 Release of Security Funds. Promptly following the end of the Term, and the complete performance of all of Seller's obligations under this Agreement, including but not limited to the obligation to pay any and all amounts owed by Seller to Company under this Agreement, Company shall release the Security Funds to Seller.

ARTICLE 15
EVENTS OF DEFAULT

- 15.1 Events of Default by Seller. The occurrence of any of the following shall constitute an Event of Default by Seller:
- (a) if at any time during the Term, Seller delivers or attempts to deliver to the Point of Interconnection for sale under this Agreement electric energy that was not generated by the Facility;
 - (b) if at any time subsequent to the Commercial Operations Date, the PV System Equivalent Availability Factor is less than **84%** for each of three consecutive Contract Years;
 - (c) if at any time subsequent to the Commercial Operations Date, the Measured Performance Ratio for each of three consecutive Contract Years falls below the Tier 2 Bandwidth for such Contract Year;
 - (d) if at any time subsequent to the Commercial Operations Date, the Seller fails to demonstrate satisfaction of the BESS Capacity Performance Metric prior to the expiration of the BESS Capacity Cure Period;
 - (e) if at any time subsequent to the Commercial Operations Date, the Seller fails to achieve a BESS Annual Equivalent Availability Factor of not less than **75%** for each of six (6) consecutive BESS Measurement Periods as provided in Section 2.8(b) (BESS Guaranteed Availability Termination Date);
 - (f) if at any time subsequent to the Commercial Operations Date, the Seller fails to demonstrate satisfaction of the RTE Performance Metric prior to the expiration of the RTE Cure Period;
 - (g) if at any time subsequent to the Commercial Operations Date, the Facility is unavailable to provide electric energy in response to Company Dispatch for a period of three hundred sixty-five (365) or more consecutive Days;
 - (h) if at any time during the Term, Seller fails to satisfy the requirements of Article 14 (Credit Assurance and Security) of this Agreement;

- (i) if at any time during the Term, Seller fails to comply with the requirements of Section 19.1 (Sale of Facility) and Attachment P (Sale of Facility by Seller); or
- (j) if at any time subsequent to the Commercial Operations Date, Seller fails to install, operate, maintain, or repair the Facility in accordance with Good Engineering and Operating Practices if such failure is not cured within thirty (30) Days after written notice of such failure from Company unless such failure cannot be cured within said thirty (30) Day period and Seller is making commercially reasonable efforts to cure such failure, in which case Seller shall have a cure period of three hundred sixty-five (365) Days after Company's written notice of such failure.

15.2 Events of Default by a Party. The occurrence of any of the following during the Term of the Agreement shall constitute an Event of Default by the Party responsible for the failure, action or breach in question:

- (a) The failure to make any payment required pursuant to this Agreement when due if such failure is not cured within ten (10) Business Days after written notice is received by the Party failing to make such payment;
- (b) Any representation or warranty made by such Party herein is false and misleading in any material respect when made;
- (c) Such Party becomes insolvent, or makes an assignment for the benefit of creditors (other than an assignment to a Facility Lender pursuant to the Financing Documents) or fails generally to pay its debts as they become due; or such Party shall have an order for relief in an involuntary case under the bankruptcy laws as now or hereafter constituted entered against it, or shall commence a voluntary case under the bankruptcy laws as now or hereafter constituted, or shall file any petition or answer seeking for itself any arrangement, composition, adjustment, liquidation, dissolution or similar relief to which it may be entitled under any present or future statute, law or regulation, or shall file any answer admitting the material allegations of any petition filed against it in such proceeding; or such Party seeks or consents to or acquiesces in the appointment of or taking possession by, any custodian,

trustee, receiver or liquidator of it or of all or a substantial part of its properties or assets; or such Party takes action looking to its dissolution or liquidation; or within ninety (90) Days after commencement of any proceedings against such Party seeking any arrangement, composition, adjustment, liquidation, dissolution or similar relief under any present or future statute, law or regulation, such proceedings shall not have been dismissed; or within ninety (90) Days after the appointment of, or taking possession by, any custodian, trustee, receiver or liquidator of any or of all or a substantial part of the properties or assets of such Party, without the consent or acquiescence of such Party, any such appointment or possession shall not have been vacated or terminated;

- (d) Such Party engages in or is the subject of a transaction requiring the prior written consent of the other Party under Section 19.2 (Assignment by Seller) or Section 19.7 (Assignment By Company) (as applicable) without having obtained such consent;
- (e) Such Party fails to comply with either (i) decision under Article 28 (Dispute Resolution), (ii) or an Independent Evaluator's decision under Article 23 (Process for Addressing Revisions to Performance Standards), in either case within thirty (30) Days after such decision becomes binding on the Parties in accordance with Article 28 (Dispute Resolution) or within thirty (30) Days of the issuance of such decision under Article 23 (Process for Addressing Revisions to Performance Standards), as applicable, or, if such decision cannot be complied with within thirty (30) Days, such Party fails to have commenced commercially reasonable efforts designed to achieve compliance within such thirty (30) Days and diligently continue such commercially reasonable efforts until compliance is attained; or
- (f) A Party, by act or omission, materially breaches or defaults on any material covenant, condition or other provision of this Agreement, other than the provisions specified in Section 15.1 (Events of Default by Seller) and Section 15.2(a) through Section 15.2(e), if such breach or default is not cured within thirty (30) Days after written notice of such breach or default from the

other Party; provided, however, that if it is objectively impossible to cure the breach or default in question within said thirty (30) Day period (i.e., if the breach or default in question is one that could not be cured within said thirty (30) Day period by an experienced independent power producer or electric utility, as applicable, willing and able to exert commercially reasonable efforts to achieve such cure within said thirty (30) Day period), then, for so long as the Non-performing Party is making the same effort to cure such breach or default as would be expected of an experienced independent power producer or electric utility, as applicable, willing and able to exert commercially reasonable efforts to achieve such cure, the Non-performing Party shall have a cure period equal to the shorter of (i) the duration of the period within which a cure could reasonably be expected to be achieved by an experienced independent power producer or electric utility, as applicable, willing and able to exert commercially reasonable efforts to achieve such cure or (ii) a period of three hundred sixty five (365) Days beginning on the date of written notice of such breach or default; provided, further, that if the material breach in question involves Seller's failure to meet the operational and performance standards set forth in Attachment B (Facility Owned by Seller), the provisions of Section 1(j) (Demonstration of Facility) of Attachment B (Facility Owned by Seller) for consultant's study and Seller implementation of such study's recommendation shall apply in lieu of the extended cure period provided under the preceding proviso.

15.3 Cure/Grace Periods. Before becoming an Event of Default, the occurrences set forth in Section 15.1 (Events of Default by Seller) and Section 15.2 (Events of Default by a Party) are subject to the following cure/grace periods:

- (a) If the occurrence is not the result of Force Majeure, the Non-performing Party shall be entitled to a cure period to the limited extent expressly set forth in the applicable provision of Section 15.1 (Events of Default by Seller) or Section 15.2 (Events of Default by a Party); or
- (b) If the occurrence is the result of Force Majeure, and if and so long as the conditions set forth in Section 21.4

(Satisfaction of Certain Conditions) are satisfied, the Non-performing Party shall be entitled to a grace period as provided in Section 21.6 (Termination for Force Majeure), which shall apply in lieu of any cure periods provided in Section 15.1 (Events of Default by Seller) and Section 15.2 (Events of Default by a Party).

- 15.4 Rights of the Non-defaulting Party; Forward Contract. If an Event of Default shall have occurred and be continuing, the Party who is not the Defaulting Party ("Non-defaulting Party") shall have the right (i) to terminate this Agreement by sending written notice to the Defaulting Party as provided in this Section 15.4 (Rights of the Non-defaulting Party; Forward Contract); (ii) to withhold any payments due to the Defaulting Party under this Agreement; (iii) suspend performance; and (iv) exercise any other right or remedy available at law or in equity to the extent permitted under this Agreement. A notice terminating this Agreement pursuant to this Section 15.4 (Rights of the Non-defaulting Party; Forward Contract) shall designate the Day such termination is to be effective which Day shall be no later than thirty (30) Days after such notice is deemed to be received by the Defaulting Party and not earlier than the first to occur of the Day such notice is deemed to be received by the Defaulting Party or the Day following the expiration of any period afforded the Defaulting Party under Section 15.1 (Events of Default by Seller) and Section 15.2 (Events of Default by a Party) to cure the default in question. If the Agreement is terminated by Company because of one or more of the Events of Default by Seller, Company shall have the right, in addition to the rights set forth above in this Section 15.4 (Rights of the Non-defaulting Party; Forward Contract), to collect Termination Damages, in accordance with Article 16 (Damages in the Event of Termination by Company). Without limitation to the generality of the foregoing provisions of this Section 15.4 (Rights of the Non-Defaulting Party; Forward Contract), the Parties agree that, under 11 U.S.C. §362(b)(6), this Agreement is a "forward contract" and the Company is a "forward contract merchant" such that upon the occurrence of an Event of Default by Seller under Section 15.1 (Events of Default by Seller) or Section 15.2 (Events of Default by a Party), this Agreement may be terminated by Company as provided in this Agreement notwithstanding any bankruptcy petition affecting Seller.

- 15.5 Force Majeure. To the extent a Non-performing Party is entitled to defer certain liabilities pursuant to Article 21 (Force Majeure) of the Agreement, the permitted period of deferral shall be governed by Section 21.6 (Termination for Force Majeure) in lieu of this Article 15 (Events of Default).
- 15.6 Guaranteed Project Milestones Including Guaranteed Commercial Operations Date. Notwithstanding any other provision of this Article 15 (Events of Default) to the contrary, any failure of Seller to achieve any of the Guaranteed Project Milestones by the applicable Guaranteed Project Milestone Date, including Commercial Operations by the Guaranteed Commercial Operations Date, shall be governed by Article 13 (Guaranteed Project Milestones Including Commercial Operations) in lieu of this Article 15 (Events of Default).
- 15.7 Equitable Remedies. Seller acknowledges that Company is a public utility and is relying upon Seller's performance of its obligations under this Agreement, and that Company and/or its customers may suffer irreparable injury as a result of the failure of Seller to perform any of such obligations, whether or not such failure constitutes an Event of Default or otherwise gives rise to one or more of the remedies set forth in Section 15.4 (Rights of the Non-defaulting Party; Forward Contract). Accordingly, the remedies set forth in Section 15.4 (Rights of the Non-defaulting Party; Forward Contract) shall not limit or otherwise affect Company's right to seek specific performance injunctions or other available equitable remedies for Seller's failure to perform any of its obligations under this Agreement, irrespective of whether such failure constitutes an Event of Default.

ARTICLE 16
DAMAGES IN THE EVENT OF TERMINATION BY COMPANY

- 16.1 Termination Due to Failure to Meet a Guaranteed Project Milestone Date. If the Agreement is terminated by Company pursuant to Section 13.4 (Damages and Termination), Company shall be entitled to Termination Damages calculated by multiplying the Contract Capacity by \$50/kW.
- 16.2 Termination Due to an Event of Default. If the Agreement is terminated by Company in accordance with this Agreement after the Commercial Operations Date due to an Event of Default where Seller is the Defaulting Party, Company shall be entitled to Termination Damages calculated by multiplying the Contract Capacity by \$75/kW.
- 16.3 Liquidated Damages Appropriate. Each Party agrees and acknowledges that (i) the damages that Company would incur due to early termination of the Agreement pursuant to either Section 13.4 (Damages and Termination) or Section 15.4 (Rights of the Non-defaulting Party; Forward Contract) would be difficult or impossible to calculate with certainty, (ii) the Termination Damages are an appropriate approximation of such damages, and (iii) payment of Termination Damages does not relieve Seller of liability for costs and balances incurred prior to the effective date of such termination. The Termination Damages are the sole and exclusive remedy for Company's losses arising out of the termination of this Agreement. The Termination Damages are not intended to limit Company's rights or remedies, or Seller's liabilities or duties, with respect to losses arising independent of the termination of this Agreement, including, without limitation, Company's right to recover under Section 17.1 (Indemnification of Company).
- 16.4 Consequential Damages. Neither Party shall be liable for damages incurred by the other Party for any loss of profit or revenues, loss of product, loss of use of products or services or associated equipment, interruption of business, cost of capital, downtime costs, increased operating costs, or for any special, consequential, incidental, indirect or punitive damages; provided, however, that nothing in this Section 16.4 (Consequential Damages) shall limit any of (i) the indemnification obligations of either Party under Article 17 (Indemnification) of this Agreement, (ii) the liability of either Party for liquidated damages as set

forth in this Agreement, (iii) the liability of either Party for direct damages for breach of this Agreement as and to the extent such damages have not been liquidated as set forth in this Agreement or (iv) the liability of either Party for gross negligence or intentional misconduct.

ARTICLE 17
INDEMNIFICATION

17.1 Indemnification of Company.

- (a) Indemnification Against Third Party Claims. Seller shall indemnify, defend, and hold harmless Company, its successors, permitted assigns, affiliates, controlling persons, directors, officers, employees, agents, contractors, subcontractors and the employees of any of them (collectively referred to as an "Indemnified Company Party"), from and against any Losses suffered, incurred or sustained by any Indemnified Company Party due to any Claim (whether or not well founded, meritorious or unmeritorious) by a third party not controlled by, or under common ownership and/or control with, Company relating to (i) Seller's development, permitting, construction, ownership, operation and/or maintenance of the Facility and Company-Owned Interconnection Facilities (excluding the ownership, operation and/or maintenance of the Company-Owned Interconnection Facilities following the Transfer Date); or (ii) any actual or alleged personal injury or death or damage to property, in any way arising out of, incident to, or resulting directly or indirectly from the acts or omissions of any Indemnified Seller Party, except as and to the extent that such Loss is attributable to the negligence or willful misconduct of an Indemnified Company Party.
- (b) Compliance with Laws. Any Losses incurred by an Indemnified Seller Party for noncompliance by Seller or an Indemnified Seller Party with applicable Laws shall not be reimbursed by Company but shall be the sole responsibility of Seller. Seller shall indemnify, defend and hold harmless each Indemnified Company Party from and against any and all Losses in any way arising out of, incident to, or resulting directly or indirectly from the failure of Seller to comply with any Laws.
- (c) Notice. If Seller shall obtain knowledge of any Claim subject to Section 17.1(a) (Indemnification Against Third Party Claims), Section 17.1(b) (Compliance with Laws) or otherwise under this Agreement, Seller shall give prompt notice thereof to Company, and if Company

shall obtain any such knowledge, Company shall give prompt notice thereof to Seller.

(d) Indemnification Procedures.

- (1) In case any Claim subject to Section 17.1(a) (Indemnification Against Third Party Claims) or Section 17.1(b) (Compliance with Laws) or otherwise under this Agreement, shall be brought against an Indemnified Company Party, Company shall notify Seller of the commencement thereof and, provided that Seller has acknowledged in writing to Company its obligation to an Indemnified Company Party under this Section 17.1 (Indemnification of Company), Seller shall be entitled, at its own expense, acting through counsel acceptable to Company, to participate in and, to the extent that Seller desires, to assume and control the defense thereof; provided, however, that Seller shall not compromise or settle a Claim against an Indemnified Company Party without the prior written consent of Company which consent shall not be unreasonably withheld or delayed.
- (2) Seller shall not be entitled to assume and control the defense of any such Claim subject to Section 17.1(a) (Indemnification Against Third Party Claims), Section 17.1(b) (Compliance with Laws) or otherwise under this Agreement, if and to the extent that, in the sole opinion of Company, such Claim involves the potential imposition of criminal liability on an Indemnified Company Party or a conflict of interest between an Indemnified Company Party and Seller, in which case Company shall be entitled, at its own expense, acting through counsel acceptable to Seller to participate in any Claim, the defense of which has been assumed by Seller. Company shall supply, or shall cause an Indemnified Company Party to supply, Seller with such information and documents requested by Seller as are necessary or advisable for Seller to possess in connection with its participation in any Claim to the extent permitted by this Section 17.1(d) (2). Company shall not enter, and shall restrict any Indemnified Company Party from entering, into any settlement or other compromise with respect to any

Claim without the prior written consent of Seller, which consent shall not be unreasonably withheld or delayed.

- (3) Upon payment of any Losses by Seller, pursuant to this Section 17.1 (Indemnification of Company) or other similar indemnity provisions contained herein, to or on behalf of Company, Seller, without any further action, shall be subrogated to any and all claims that an Indemnified Company Party may have relating thereto.
- (4) Company shall fully cooperate and cause all Company Indemnified Parties to fully cooperate, in the defense of or response to, any Claim subject to Section 17.1 (Indemnification of Company).

17.2 Indemnification of Seller.

- (a) Indemnification Against Third Party Claims. Company shall indemnify, defend, and hold harmless Seller, its successors, permitted assigns, affiliates, controlling persons, directors, officers, employees, servants and agents, contractors, subcontractors and the employees of any of them (collectively referred to as an "Indemnified Seller Party"), from and against any Losses suffered, incurred or sustained by any Indemnified Seller Party due to any Claim (whether or not well founded, meritorious or unmeritorious) by a third party not controlled by or under common ownership and/or control with Seller relating to (i) the ownership, operation and/or maintenance of the Company-Owned Interconnection Facilities following the Transfer Date, and (ii) any actual or alleged personal injury or death or damage to property, in any way arising out of, incident to, or resulting directly or indirectly from the acts or omissions of any Indemnified Company Party, except to the extent that any such Loss is attributable to the negligence or willful misconduct of an Indemnified Seller Party.
- (b) Compliance with Laws. Any Losses incurred by an Indemnified Company Party for noncompliance by Company or an Indemnified Company Party with applicable Laws shall not be reimbursed by Seller but shall be the sole responsibility of Company. Company shall indemnify, defend and hold harmless each Indemnified Seller Party

from and against any and all Losses in any way arising out of, incident to, or resulting directly or indirectly from the failure of Company to comply with any Laws.

- (c) Notice. If Company shall obtain knowledge of any Claim subject to Section 17.2(a) (Indemnification Against Third Party Claims), Section 17.2(b) (Compliance with Laws) or otherwise under this Agreement, Company shall give prompt notice thereof to Seller, and if Seller shall obtain any such knowledge, Seller shall give prompt notice thereof to Company.
- (d) Indemnification Procedures.
- (1) In case any Claim subject to Section 17.2(a) (Indemnification Against Third Party Claims), Section 17.2(b) (Compliance with Laws), or otherwise under this Agreement, shall be brought against an Indemnified Seller Party, Seller shall notify Company of the commencement thereof and, provided that Company has acknowledged in writing to Seller its obligation to an Indemnified Seller Party under this Section 17.2 (Indemnification of Seller), Company shall be entitled, at its own expense, acting through counsel acceptable to Seller, to participate in and, to the extent that Company desires, to assume and control the defense thereof; provided, however, that Company shall not compromise or settle a Claim against an Indemnified Seller Party without the prior written consent of Seller which consent shall not be unreasonably withheld or delayed.
- (2) Company shall not be entitled to assume and control the defense of any such Claim subject to Section 17.2(a) (Indemnification Against Third Party Claims), Section 17.2(b) (Compliance with Laws), or otherwise under this Agreement, if and to the extent that, in the opinion of Seller, such Claim involves the potential imposition of criminal liability on an Indemnified Seller Party or a conflict of interest between an Indemnified Seller Party and Company, in which case Seller shall be entitled, at its own expense, acting through counsel acceptable to Company, to participate in any Claim the defense of which has been assumed by

Company. Seller shall supply, or shall cause an Indemnified Seller Party to supply, Company with such information and documents requested by Company as are necessary or advisable for Company to possess in connection with its participation in any Claim, to the extent permitted by this Section 17.2(d)(2). Seller shall not enter, and shall restrict any Indemnified Seller Party from entering, into any settlement or other compromise with respect to any Claim without the prior written consent of Company, which consent shall not be unreasonably withheld or delayed.

- (3) Upon payment of any Losses by Company pursuant to this Section 17.2 (Indemnification of Seller) or other similar indemnity provisions contained herein to or on behalf of Seller, Company, without any further action, shall be subrogated to any and all claims that an Indemnified Seller Party may have relating thereto.
- (4) Seller shall fully cooperate and cause all Seller Indemnified Parties to fully cooperate, in the defense of, or response to, any Claim subject to Section 17.2 (Indemnification of Seller).

ARTICLE 18
INSURANCE

- 18.1 Required Coverage. Seller, and anyone acting under its direction or control or on its behalf, shall, at its own expense, acquire and maintain, or cause to be maintained in full effect, commencing with the start of construction of the Facility, as applicable, and continuing throughout the Term, as applicable, the minimum insurance coverage set forth in Attachment R (Required Insurance), or such higher amounts as the Seller and/or the Facility Lender reasonably determines to be necessary during construction and operation of the Facility. Seller's indemnity and other obligations shall not be limited by the foregoing insurance requirements.
- 18.2 Waiver of Subrogation. Seller, and anyone acting under its direction or control or on its behalf, shall cause its insurers to waive all rights of subrogation which Seller or its insurers may have against Company, Company's agents, or Company's employees.
- 18.3 Additional Insureds. The insurance policies specified in Section 2 (General Liability Insurance) and Section 3 (Automobile Liability Insurance) of Attachment R (Required Insurance) shall name Company as an additional insured, as its interests may appear, with respect to any and all third party bodily injury and/or property damage claims, including completed operations, arising from Seller's performance of this Agreement, and Seller shall submit to Company a copy of such additional insured endorsement with evidence of insurance as required herein. Seller shall promptly, and in no event later than 5 Days after such cancellation, modification or non-renewal, provide written notice to Company should any of the insurance policies required under this Agreement be cancelled, materially modified, or not renewed upon expiration. Company acknowledges that the Facility Lender shall be entitled to receive and distribute any and all loss proceeds as stipulated by any Financing Documents related to any policy described in this Article 18 (Insurance) and Attachment R (Required Insurance).
- 18.4 Evidence of Policies Provided to Company. Evidence of insurance for the coverage specified in this Article 18 (Insurance) shall be provided to Company within thirty (30) Days after the Effective Date or prior to the start of

construction, whichever shall first occur. Within 30 Days of any change of any policy and upon renewal of any policy, Seller shall provide certificates of insurance to Company. During the Term, Seller, upon Company's reasonable request, shall make available to Company for its inspection at Seller's designated location, certified copies of the insurance policies described in this Article 18 (Insurance) and Attachment R (Required Insurance). Receipt of any evidence of insurance showing less coverage than requested is not a waiver of Seller's obligations to fulfill the requirements.

- 18.5 Deductibles. Company acknowledges that any policy required herein may contain reasonable deductibles or self-insured retentions, the amounts of which will be reviewed for acceptance by Company. Acceptance will not be unreasonably withheld. Any deductible shall be the responsibility of Seller.
- 18.6 Application of Proceeds from All Risk Property/Comprehensive Boiler and Machinery Insurance. Seller shall use commercially reasonable efforts to obtain provisions in the Financing Documents, on reasonable terms, providing for the insurance proceeds from All Risk Property/Comprehensive Boiler and Machinery Insurance to be applied to repair of the Facility.
- 18.7 Annual Review by Company. The coverage limits shall be reviewed annually by Company and if, in Company's discretion, Company determines that the coverage limits should be increased, Company shall so notify Seller. The amount of any increase of the coverage limits, when considered as a percentage of the then existing coverage limits, shall not exceed the cumulative amount of increase in the Consumer Price Index occurring after the coverage limits herein were last set. Seller shall, within thirty (30) Days of notice from Company, increase the coverage as directed in such notice and the costs of such increased coverage limits shall be borne by Seller.
- 18.8 No Representation of Coverage Adequacy. By requiring insurance herein, Company does not represent that coverage and limits will necessarily be adequate to protect Seller, and such coverage and limits shall not be deemed as a limitation on Seller's liability under the indemnities granted to Company in this Agreement.

18.9 Subcontractors. Seller shall ensure that each of its subcontractors is either (a) named as an additional insured under the insurance policies procured by Seller; or (b) separately covered by insurance policies equivalent in type and monetary limits as those required of Seller. All such insurance shall be provided at the sole cost of Seller or subcontractor.

18.10 General Insurance Requirements.

- (a) Each policy shall be specifically endorsed by blanket or otherwise to provide that Seller's insurance is primary. Any other insurance carried by Company will be excess only and not contribute with this insurance.
- (b) Each policy is to be written by an insurer with a rating by A.M. Best Company, Inc. of "A-VII" or better.
- (c) If any policy required herein is written on a claims-made basis, the Seller warrants that any retroactive date applicable to coverage under the policy precedes the Execution Date; and that continuous coverage will be maintained or an extended discovery period will be exercised for a period of three (3) years beginning from the end of Term.
- (d) If the limits of available liability coverage required herein become substantially reduced as a result of claim payments, Seller shall promptly, and in no event later than thirty (30) Days after such substantial reduction, at its own expense, purchase additional liability insurance (if such coverage is available at commercially reasonable rates) to increase the amount of available coverage to the limits of liability coverage required herein.

ARTICLE 19
TRANSFERS, ASSIGNMENTS, AND FACILITY DEBT

- 19.1 Sale of the Facility. Seller shall comply with the requirements of Attachment P (Sale of Facility by Seller) before Seller's right, title or interest in the Facility, in whole or in part, including a Change in Control, may be disposed of (other than the disposition of equipment in the ordinary course of operating and maintaining the Facility). Any attempt by Seller to make any such disposition or Change in Control without fulfilling the requirements of Attachment P (Sale of Facility by Seller) shall be deemed null and void and shall constitute an Event of Default pursuant to Article 15 (Events of Default).
- 19.2 Assignment by Seller. This Agreement may not be assigned by Seller without the prior written consent of Company (such consent not to be unreasonably withheld, conditioned or delayed), provided that Seller shall have the right, without the consent of Company, to assign its interest in this Agreement (i) to a wholly-owned subsidiary or to an affiliated company under common control with **[Note - insert appropriate parent entity]**, provided that such assignment does not impair the ability of Seller to perform its obligations under this Agreement; and (ii) as collateral security for purposes of arranging or rearranging debt and/or equity financing for the Facility, or for sale-leaseback financing, to assign all or any part of its rights or benefits, but not its obligations, to any lender providing debt financing for the Facility. Seller shall promptly provide written notice to Company of any assignment of all or part of this Agreement and Seller shall provide to Company information about the assignee and the assignee's operational experience reasonably requested by Company. Company shall not be required to incur any duty or obligation as a result of, or in connection with, such assignment made without its consent beyond those duties and obligations set forth in this Agreement, unless otherwise agreed to by Company in writing.
- 19.3 Company's Acknowledgment. In connection with any assignment relating to the Facility Debt pursuant to Section 19.2 (Assignment by Seller), Company shall, if requested by Seller and if its costs (including reasonable attorneys' fees of outside counsel) in responding to such request are paid by Seller: (i) execute and/or provide such Hawai'i-law

governed documents as may be reasonably requested by the Facility Lender and reasonably acceptable to Company, including, (aa) to acknowledge (1) such assignment and/or pledge/mortgage, (2) the right of the Facility Lender to receive copies of notices of Events of Default where the Seller is the Defaulting Party and (3) the Facility Lender's reasonable opportunity to cure such Events of Default and to exercise remedies to assume Seller's obligations under this Agreement, and (bb) estoppel certificates as to Seller's and Company's compliance with the terms and conditions of this Agreement; and (ii) provide a legal opinion as to the due authorization of such Company acknowledgment and estoppels.

19.4 Financing Document Requirements. Seller shall include in the terms of the Financing Documents as provisions for Company's benefit that provide that as a condition to the Facility Lender, or any purchaser, successor, assignee and/or designee of the Facility Lender ("Subsequent Owner"), succeeding to ownership or possession of the Facility as a result of the exercise of remedies under the Financing Documents, and thereafter operating the Facility to generate electric energy, such Facility Lender or Subsequent Owner shall, prior to operating the Facility for such purpose, have provided to Company, evidence reasonably acceptable to Company that such Subsequent Owner has (a) the qualifications, or has contracted with an entity having the qualifications, to operate the Facility in a manner consistent with the terms and conditions of this Agreement; and (b) assumed all of Seller's rights and obligations under this Agreement.

19.5 [Reserved]

19.6 Reimbursement of Company Costs. Seller shall reimburse Company for costs and expenses incurred by Company (including reasonable attorneys' fees of outside counsel) in responding to Facility Lender's requests or as a result of any event of default by Seller under the Financing Documents, including but not limited to any assumption of Seller's obligations under Section 19.4 (Financing Document Requirements).

19.7 Assignment By Company. This Agreement shall not be assigned by Company without the prior written consent of Seller (which consent shall not be unreasonably withheld, conditioned or delayed); provided, however, that Company

shall have the right, without the consent of Seller, to assign its interest in this Agreement to any affiliated company owned in whole or in part by Hawaiian Electric Industries, Inc. ("HEI") so long as such assignee (a) shall have assumed all obligations of Company under this Agreement; and (b) is a utility regulated by the PUC.

- 19.8 Consequences for Failure to Comply. Any attempt to make any pledge, mortgage, grant of a security interest or collateral assignment for which consent is required under Section 19.2 (Assignment by Seller) or Section 19.7 (Assignment By Company) (as applicable), without fulfilling the requirements of this Article 19 (Transfers, Assignments, and Facility Debt) shall be null and void and shall constitute an Event of Default pursuant to Article 15 (Events of Default).

ARTICLE 20
SALE OF ENERGY TO THIRD PARTIES

Seller shall not sell energy from the Facility to any Third Party.

ARTICLE 21
FORCE MAJEURE

21.1 Definition of Force Majeure. The term "Force Majeure", as used in this Agreement, means any occurrence that:

- (a) In whole or in part delays or prevents a Party's performance under this Agreement;
- (b) Is not the direct or indirect result of the fault or negligence of that Party;
- (c) Is not within the control of that Party notwithstanding such Party having taken all reasonable precautions and measures in order to prevent or avoid such event; and
- (d) The Party has been unable to overcome by the exercise of due diligence.

21.2 Events That Could Qualify as Force Majeure. Subject to the foregoing, events that could qualify as Force Majeure include, but are not limited to, the following:

- (a) acts of God, flooding, lightning, landslide, earthquake, fire, drought, explosion, epidemic, quarantine, storm, hurricane, tornado, volcano, other natural disaster or unusual or extreme adverse weather-related events;
- (b) war (declared or undeclared), riot or similar civil disturbance, acts of the public enemy (including acts of terrorism), sabotage, blockade, insurrection, revolution, expropriation or confiscation; or
- (c) except as set forth in Section 21.3(j), strikes, work stoppage or other labor disputes (in which case the affected Party shall have no obligation to settle the strike or labor dispute on terms it deems unreasonable).

21.3 Exclusions From Force Majeure. Force Majeure does not include:

- (a) any acts or omissions of any Third Party, including, without limitation, any vendor, materialman, customer, or supplier of Seller, unless such acts or omissions are themselves excused by reason of Force Majeure;

- (b) any full or partial reduction in the electric output of Facility that is caused by or arises from (i) a mechanical or equipment breakdown or (ii) other mishap or events or conditions attributable to normal wear and tear or defects, unless such mishap is caused by Force Majeure;
- (c) changes in market conditions that affect the cost of Seller's supplies, or that affect demand or price for any of Seller's products, or that otherwise render this Agreement uneconomic or unprofitable for Seller;
- (d) Seller's inability to obtain Governmental Approvals or Land Rights for the construction, ownership, operation and maintenance of Facility and the Company-Owned Interconnection Facilities, or Seller's loss of any such Governmental Approvals or Land Rights once obtained;
- (e) the lack of wind, sun or any other resource of an inherently intermittent nature;
- (f) Seller's inability to obtain sufficient fuel, power or materials to operate its Facility, except if Seller's inability to obtain sufficient fuel, power or materials is caused solely by an event of Force Majeure;
- (g) Seller's failure to obtain additional funds, including funds authorized by a state or the federal government or agencies thereof, to supplement the payments made by Company pursuant to this Agreement;
- (h) a forced outage except where such forced outage is caused by an event of Force Majeure;
- (i) litigation or administrative or judicial action pertaining to the Agreement, the Site, the Facility, the Land Rights, the acquisition, maintenance or renewal of financing or any Governmental Approvals, or the design, construction, ownership, operation or maintenance of the Facility, the Company-Owned Interconnection Facilities or the Company System;
- (j) a strike, work stoppage or labor dispute limited only to any one or more of the Indemnified Seller Parties or any other third party employed by Seller to work on the Project; or

- (k) any full or partial reduction in the availability of the Facility to produce and deliver to the Point of Interconnection electric energy in response to Company Dispatch which is caused by any Third Party including, without limitation, any vendor or supplier of Seller or Company, except to the extent due to Force Majeure.

21.4 Satisfaction of Certain Conditions. Section 21.5 (Guaranteed Project Milestones Including Commercial Operations), Section 21.6 (Termination for Force Majeure) and Section 21.7 (Effect of Force Majeure) defer or limit certain liabilities of a Party for delay and/or failure in performance to the extent such delay or failure is the result of conditions or events of Force Majeure; provided, however, that a Non-performing Party is only entitled to such limitations or deferrals of liabilities as and to the extent the following conditions are satisfied:

- (a) the Non-performing Party gives the other Party, within five (5) Days after the Non-performing Party becomes aware or should have become aware of the Force Majeure condition or event, but in any event no later than thirty (30) Days after the Force Majeure condition or event begins, written notice (the "Force Majeure Notice") stating that the Non-performing Party considers such condition or event to constitute Force Majeure and describing the particulars of such Force Majeure condition or event, including the date the Force Majeure commenced;
- (b) the Non-performing Party gives the other Party, within fourteen (14) Days after the Force Majeure Notice was or should have been provided, a written explanation of the Force Majeure condition or event and its effect on the Non-performing Party's performance, which explanation shall include evidence reasonably sufficient to establish that the occurrence constitutes Force Majeure;
- (c) the suspension of performance is of no greater scope and of no longer duration than is required by the condition or event of Force Majeure;
- (d) the Non-performing Party exercises commercially reasonable efforts to remedy its inability to perform and provides written weekly progress reports to the other Party describing actions taken to end the Force Majeure; and

- (e) when the condition or event of Force Majeure ends and the Non-performing Party is able to resume performance of its obligations under this Agreement, that Party shall give the other Party written notice to that effect.
- 21.5 Guaranteed Project Milestones Including Commercial Operations. The Parties shall have the rights and obligations set forth in Article 13 (Guaranteed Project Milestones Including Commercial Operations) in the event a condition or event of Force Majeure affects the achievement of a Guaranteed Project Milestone Date, including the Guaranteed Commercial Operations Date.
- 21.6 Termination for Force Majeure. If Force Majeure delays or prevents a Party's performance for more than three hundred sixty-five (365) Days from the occurrence or inception of the Force Majeure, as stated in the Force Majeure Notice, and such delay or failure of performance would have otherwise constituted an Event of Default under Article 15 (Event of Default), the other Party shall have the right to terminate this Agreement by written notice. Such notice shall designate the date such termination is to be effective, which date shall be no later than thirty (30) Days after such notice is deemed to be received by the Party whose performance has been delayed or prevented. In the event of termination pursuant to this Section 21.6 (Termination for Force Majeure), neither Party shall be liable for any damages or have any obligations to the other, except as provided in Section 29.25 (Survival of Obligations) other than as provided in Section 29.25(b).
- 21.7 Effect of Force Majeure. Other than as provided in Section 21.5 (Guaranteed Project Milestones Including Commercial Operations) and Section 21.6 (Termination for Force Majeure), neither Party shall be responsible or liable for any delays or failures in its performance under this Agreement as and to the extent (i) such delays or failures are substantially caused by conditions or events of Force Majeure, and (ii) the conditions of Section 21.4 (Satisfaction of Certain Conditions) are satisfied.
- 21.8 No Relief of Other Obligations. Except as otherwise expressly provided for in this Agreement, the existence of a condition or event of Force Majeure shall not relieve the Parties of their obligations under this Agreement

(including, but not limited to, payment obligations) to the extent that performance of such obligations is not precluded by the condition or event of Force Majeure.

- 21.9 No Extension of the Term. In no event will any delay or failure of performance caused by any conditions or events of Force Majeure extend this Agreement beyond its stated Term.

ARTICLE 22
WARRANTIES AND REPRESENTATIONS

22.1 By the Parties. Both Company and Seller represent, warrant, and covenant, as of the Execution Date and for the extent of the Term, respectively, that:

- (a) Each respective Party has all necessary right, power and authority to execute, deliver and perform this Agreement.
- (b) The execution, delivery and performance of this Agreement by each respective Party will not result in a violation of any Laws, or conflict with, or result in a breach of, or cause a default under, any agreement or instrument to which such Party is also a party or by which it is bound. No consent of any person or entity not a Party to this Agreement, including any Governmental Authority (other than agencies whose approval is necessary for the development, construction, operation and maintenance of the Facility and the Company-Owned Interconnection Facilities or the PUC), is required for such execution, delivery and performance by either Party.

22.2 By Seller. Seller represents, warrants, and covenants that:

- (a) As of the Execution Date and for the extent of the Term, it is an entity in good standing with the Hawai'i Department of Commerce and Consumer Affairs and shall provide Company with a certified copy of a certificate of good standing by the Execution Date.
- (b) As of the Execution Date, Seller is a subsidiary of [_____], a company with extensive experience developing, constructing, owning and operating utility-scale renewable energy generation facilities.
- (c) Seller has obtained or will obtain Land Rights within the time periods set forth in Section 11.2 (Land Rights for Facility) and Section 11.3 (Company-Owned Interconnection Facilities).
- (d) At the time legally required, Seller shall have obtained (i) all Governmental Approvals for the construction, ownership, operation and maintenance of the Company-Owned Interconnection Facilities and (ii) all

Governmental Approvals necessary for the construction, ownership, operation and maintenance of the Facility.

- (e) As of the Commercial Operations Date, the Facility will be a qualified renewable resource under RPS in effect as of the Effective Date.

ARTICLE 23
PROCESS FOR ADDRESSING
REVISIONS TO PERFORMANCE STANDARDS

- 23.1 Revisions to Performance Standards. The Parties acknowledge that, during the Term, certain Performance Standards and Telemetry and Control interfaces may be revised or added to facilitate necessary improvements in integrating intermittent variable energy resources and/or energy storage resources into the Company System and operations. Such revisions or additions may be attributable to, without limitation, the following: changes in penetration levels of intermittent renewable resources on the Company System, changes in the Company System, changes in communications and control platforms, changes in system protection requirements, changes to the state of commercially available technology, changes to Company-owned generation resources, changes in customer electrical usage (such as changes in average hourly load profiles), and changes in Laws (e.g., new environmental constraints, which may limit Company's ability to start/stop its generators in response to integration of intermittent generation, or constraints impacting the power quality standards for the Company System, such as constraints imposed by HERA or by the PUC under the HERA Law). Changes in Facility characteristics achieved through control system configuration, settings, or other tunable parameters shall not be considered a revision to performance standards. These types of changes should be implemented by the Seller in response to Company request unless it can be shown that the changes negatively impact the Seller's ability to meet its obligations under this Agreement.
- 23.2 Performance Standards Information Request. If Company concludes that a Performance Standards Revision is necessary or important for the operation of the Company System and is capable of being complied with by Seller, Company shall have the right to issue to Seller a Performance Standards Information Request with respect to such Performance Standards Revision. Seller shall, within a reasonable period of time following Seller's receipt of such Performance Standards Information Request, but in no event more than 90 Days after Seller's receipt of such Request (or such other period of time as Company and Seller may agree in writing), submit to Company a Performance Standards Proposal

responsive to the Performance Standards Revision proposed in such Performance Standards Information Request.

- 23.3 Performance Standards Proposal. Upon receipt of a Performance Standards Proposal submitted in response to a Performance Standards Information Request, Company will evaluate such Performance Standards Proposal and Seller shall assist Company in performing such evaluation as and to the extent reasonably requested by Company (including, but not limited to, providing such additional information as Company may reasonably request and participating in meetings with Company as Company may reasonably request). Company shall have no obligation to evaluate a Performance Standards Proposal submitted at Seller's own initiative.
- 23.4 Performance Standards Revision Document. If, following Company's evaluation of a Performance Standards Proposal, Company desires to consider implementing the Performance Standards Revision addressed in such Proposal, Company shall provide Seller with written notice to that effect, such notice to be issued to Seller within 180 Days of receipt of the Performance Standards Proposal, and Company and Seller shall proceed to negotiate in good faith a Performance Standards Revision Document setting forth the specific changes to the Agreement that are necessary to implement such Performance Standards Revision. A decision by Company to initiate negotiations with Seller as aforesaid shall not constitute an acceptance by Company of any of the details set forth in Seller's Performance Standards Proposal for the Performance Standards Revision in question, including but not limited to the Performance Standards Modifications and the Performance Standards Pricing Impact. Any adjustment to the Contract Pricing pursuant to such Performance Standards Revision Document shall be limited to the Performance Standards Pricing Impact (other than with respect to the financial consequences of non-performance as to a Performance Standards Revision). The time periods set forth in such Performance Standards Revision Document as to the effective date for the Performance Standards Revision shall be measured from the date the PUC Performance Standards Revision Order becomes non-appealable as provided in Section 23.6 (PUC Performance Standards Revision Order).
- 23.5 Failure to Reach Agreement. If Company and Seller are unable to agree upon and execute a Performance Standards Revision Document within 180 Days of Company's written

notice to Seller pursuant to Section 23.4 (Performance Standards Revision Document), Company shall have the option of declaring the failure to reach agreement on and execute such Performance Standards Revision Document to be a dispute and submit such dispute to an Independent Evaluator for the conduct of a determination pursuant to Section 23.10 (Dispute) of this Agreement. Any decision of the Independent Evaluator, rendered as a result of such dispute shall include a form of a Performance Standards Revision Document as described in Section 23.4 (Performance Standards Revision Document).

23.6 PUC Performance Standards Revision Order. No Performance Standards Revision Document shall constitute an amendment to the Agreement unless and until a PUC Performance Standards Revision Order issued with respect to such Document has become non-appealable. Once the condition of the preceding sentence has been satisfied, such Performance Standards Revision Document shall constitute an amendment to this Agreement. To be "non-appealable" under this Section 23.6 (PUC Performance Standards Revision Order), such PUC Performance Standards Revision Order shall be either (i) not subject to appeal to any Circuit Court of the State of Hawai'i or the Supreme Court of the State of Hawai'i, because the thirty (30) Day period (accounting for weekends and holidays as appropriate) permitted for such an appeal has passed without the filing of notice of such an appeal, or (ii) affirmed on appeal to any Circuit Court of the State of Hawai'i or the Supreme Court, or the Intermediate Appellate Court upon assignment by the Supreme Court, of the State of Hawai'i, or affirmed upon further appeal or appellate process, and is not subject to further appeal, because the jurisdictional time permitted for such an appeal (and/or further appellate process such as a motion for reconsideration or an application for writ of certiorari) has passed without the filing of notice of such an appeal (or the filing for further appellate process).

23.7 Company's Rights. The rights granted to Company under Section 23.4 (Performance Standards Revision Document) and Section 23.5 (Failure to Reach Agreement) above are exclusive to Company. Seller shall not have a right to initiate negotiations of a Performance Standards Revision Document or to initiate dispute resolution under Section 23.10 (Dispute), as a result of a failure to agree upon and execute any Performance Standards Revision Document.

- 23.8 Seller's Obligation. Notwithstanding any provision of this Article 23 (Process for Addressing Revisions to Performance Standards) to the contrary, Seller shall have no obligation to respond to more than one Performance Standards Information Request during any 12-month period.
- 23.9 Limited Purpose. This Article 23 (Process for Addressing Revisions to Performance Standards) is intended to specifically address necessary revisions to the Performance Standards and Telemetry and Control interfaces to enhance integration of intermittent resources and energy storage resources onto Company System, or to comply with future Laws which may be driven in part by higher integration of intermittent resources and/or energy storage resources, and is not intended for either Party to provide a means for renegotiating any other terms of this Agreement. Revisions to the Performance Standards in accordance with the provisions of this Article 23 (Process for Addressing Revisions to Performance Standards) are not intended to materially increase Seller's risk of non-performance or default.
- 23.10 Dispute. If Company decides to declare a dispute as a result of the failure to reach agreement and execute a Performance Standards Revision Document pursuant to Section 23.5 (Failure to Reach Agreement), it shall provide written notice to that effect to Seller. Within 20 Days of delivery of such notice Seller and Company shall agree upon an Independent Evaluator to resolve the dispute regarding a Performance Standards Revision Document. The Independent Evaluator shall be reasonably qualified and expert in renewable energy power generation, matters relating to the Performance Standards, financing, and power purchase agreements. If the Parties are unable to agree upon an Independent Evaluator within such 20-Day period, Company shall apply to the PUC for the appointment of an Independent Evaluator. If an Independent Observer retained under the Competitive Bidding Framework is qualified and willing and available to serve as Independent Evaluator, the PUC shall appoint one of the persons or entities qualified to serve as an Independent Observer to be the Independent Evaluator; if not, the PUC shall appoint another qualified person or entity to serve as Independent Evaluator. In its application, Company shall ask the PUC to appoint an Independent Evaluator within 30 Days of the application.

- (a) Promptly upon appointment, the Independent Evaluator shall request the Parties to address the following matters within the next 15 Days:
- (1) The Performance Standard Revision(s);
 - (2) The technical feasibility of complying with the Performance Standard Revision(s) and likelihood of compliance;
 - (3) How Seller would comply with the Performance Standard Revision(s);
 - (4) Reasonably expected net costs and/or lost revenues associated with the Performance Standards Revision(s);
 - (5) The appropriate level, if any, of Performance Standards Pricing Impact in light of the foregoing; and
 - (6) Contractual consequences for non-performance that are commercially reasonable under the circumstances.
- (b) Within 90 Days of appointment, the Independent Evaluator shall render a decision unless the Independent Evaluator determines it needs to have additional time, not to exceed 45 Days, to render a decision.
- (c) The Parties shall assist the Independent Evaluator throughout the process of preparing its review, including making key personnel and records available to the Independent Evaluator, but neither Party shall be entitled to participate in any meetings with personnel of the other Party or review of the other Party's records. However, the Independent Evaluator will have the right to conduct meetings, hearings or oral arguments in which both Parties are represented. The Parties may meet with each other during the review process to explore means of resolving the matter on mutually acceptable terms.
- (d) The following standards shall be applied by the Independent Evaluator in rendering his or her decision:
- (i) if it is not technically or operationally feasible for Seller to comply with a Performance Standard

Revision, the Independent Evaluator shall determine that the Agreement shall not be amended to incorporate such Performance Standard Revision (unless the Parties agree otherwise); (ii) if it is technically or operationally feasible for Seller to comply with a Performance Standard Revision, the Independent Evaluator shall incorporate such Performance Standard Revision into a Performance Standards Revision Document including (aa) Seller's Performance Standards Modifications, (bb) pricing terms that incorporate the Performance Standards Pricing Impact, and (cc) contract terms and conditions that are commercially reasonable under the circumstances, especially with respect to the consequences of non-performance by Seller as to Performance Standards Revision(s). In addition to the Performance Standards Revision Document, the Independent Evaluator shall render a decision which sets forth the positions of the Parties and Independent Evaluator's rationale for his or her decisions on disputed issues.

- (e) The fees and costs of the Independent Evaluator shall be paid by Company up to the first \$30,000 of such fees and costs; above those amounts, the Party that is not the prevailing Party shall be responsible for any such fees and costs; provided, if neither Party is the prevailing Party, then the fees and costs of the Independent Evaluator above \$30,000, shall be borne equally by the Parties. The Independent Evaluator in rendering his or her decision shall also state which Party prevailed over the other Party, or that neither Party prevailed over the other.

23.11 HERA Law. The provisions of this Article 23 (Process for Addressing Revisions to Performance Standards) are without limitation to the obligations of the Parties under the HERA Law and the reliability standards and interconnection requirements developed and adopted by the PUC pursuant to the HERA Law.

ARTICLE 24
FINANCIAL COMPLIANCE

- 24.1 Financial Compliance. Seller shall provide or cause to be provided to Company on a timely basis, as reasonably determined by Company, all information, including but not limited to information that may be obtained in any audit referred to below (the "Financial Compliance Information"), reasonably requested by Company for purposes of permitting Company and its parent company, HEI, to comply with the requirements (initial and on-going) of (i) the accounting principles of Financial Accounting Standards Board ("FASB") Accounting Standards Codification 810, Consolidation ("FASB ASC 810"), (ii) Section 404 of the Sarbanes-Oxley Act of 2002 ("SOX 404"), and (iii) all clarifications, interpretations and revisions of and regulations implementing FASB ASC 810 and SOX 404, issued by the FASB, Securities and Exchange Commission, the Public Company Accounting Oversight Board, Emerging Issues Task Force or other Governmental Authorities. In addition, if required by Company in order to meet its compliance obligations, Seller shall allow Company or its independent auditor to audit, to the extent reasonably required, Seller's financial records, including its system of internal controls over financial reporting; provided, however, that Company shall be responsible for all costs associated with the foregoing, including but not limited to Seller's reasonable internal costs. Company shall limit access to such Financial Compliance Information to persons involved with such compliance matters and restrict persons involved in Company's monitoring, dispatch or scheduling of Seller and/or Facility, or the administration of this Agreement, from having access to such Financial Compliance Information (unless approved in writing in advance by Seller).
- 24.2 Confidentiality. Company shall, and shall cause HEI to, maintain the confidentiality of the Financial Compliance Information as provided in this Article 24 (Financial Compliance). Company may share the Information on a confidential basis with HEI and the independent auditors and attorneys for HEI. (Company, HEI, and their respective independent auditors and attorneys are collectively referred to in this Article 24 (Financial Compliance) as "Recipient".) If either Company or HEI, in the exercise of their respective reasonable judgments, concludes that consolidation or financial reporting with respect to Seller

and/or this Agreement is necessary, Company and HEI each shall have the right to disclose such of the Financial Compliance Information as Company or HEI, as applicable, reasonably determines is necessary to satisfy applicable disclosure and reporting or other requirements and give Seller prompt written notice thereof (in advance to the extent practicable under the circumstances). If Company or HEI disclose Financial Compliance Information pursuant to the preceding sentence, Company and HEI shall, without limitation to the generality of the preceding sentence, have the right to disclose Financial Compliance Information to the PUC and the Division of Consumer Advocacy of the Department of Commerce and Consumer Affairs of the State of Hawai'i ("Consumer Advocate") in connection with the PUC's rate making activities for Company and other HEI affiliated entities, provided that, if the scope or content of the Financial Compliance Information to be disclosed to the PUC exceeds or is more detailed than that disclosed pursuant to the preceding sentence, such Financial Compliance Information will not be disclosed until the PUC first issues a protective order to protect the confidentiality of such Financial Compliance Information. Neither Company nor HEI shall use the Financial Compliance Information for any purpose other than as permitted under this Article 24 (Financial Compliance).

- 24.3 Required Disclosure. In circumstances other than those addressed in Section 24.2 (Confidentiality), if any Recipient becomes legally compelled under applicable Laws or by legal process (e.g., deposition, interrogatory, request for documents, subpoena, civil investigative demand or similar process) to disclose all or a portion of the Financial Compliance Information, such Recipient shall undertake reasonable efforts to provide Seller with prompt notice of such legal requirement prior to disclosure so that Seller may seek a protective order or other appropriate remedy and/or waive compliance with the terms of this Article 24 (Financial Compliance). If such protective order or other remedy is not obtained, or if Seller waives compliance with the provisions at this Article 24 (Financial Compliance), Recipient shall furnish only that portion of the Financial Compliance Information which it is legally required to so furnish and to use reasonable efforts to obtain assurance that confidential treatment will be accorded to any disclosed material.

24.4 Exclusions from Confidentiality. The obligation of nondisclosure and restricted use imposed on each Recipient under this Article 24 (Financial Compliance) shall not extend to any portion(s) of the Financial Compliance Information which (i) was known to such Recipient prior to receipt, or (ii) without the fault of such Recipient is available or becomes available to the general public, or (iii) is received by such Recipient from a Third Party not bound by an obligation or duty of confidentiality.

24.5 Consolidation. Company does not want to be subject to consolidation as set forth in FASB ASC 810, as issued and amended from time to time by FASB.

(a) Consolidation. Company represents that, as of the Execution Date, it is not required to consolidate Seller into its financial statements in accordance with relevant accounting guidance under U.S. generally accepted accounting principles ("GAAP"). If, due to a change in applicable law or accounting guidance under U.S. GAAP, or as a result of a material amendment to the Agreement, in each case, after the Execution Date, Company determines, in its sole but good faith discretion, that it is required to consolidate Seller into its financial statements in accordance with relevant accounting guidance in accordance with U.S. GAAP, then Seller, upon Company's written request, shall, as soon as reasonably practicable (but in no event longer than fifteen (15) Days) provide audited financial statements (including footnotes) in accordance with U.S. GAAP (and as of the reporting periods Company is required to report thereafter) in order for Company to consolidate and file its financial statements within the reporting deadlines of the Securities and Exchange Commission; provided, however, that if Seller does not normally prepare audited financial statements for the periods requested, Company shall reimburse Seller fifty percent (50%) of the reasonable costs of having necessary audits performed and preparation of the audited financial statement; provided, further that the foregoing reimbursement shall only apply if Seller normally prepares financial statements on an annual basis. Notwithstanding the foregoing requirement that Seller provide audited financial statements to Company, the Parties will take all commercially reasonable steps, which may include modification of this Agreement to

eliminate the consolidation treatment, while preserving the economic "benefit of the bargain" to both Parties. If the Parties are unable to eliminate the consolidation treatment by other means, the Parties shall effectuate a sale of the Facility to Company at (i) if the sale occurs before the end of the thirteenth (13th) Contract Year, the greater of the Make Whole Amount determined pursuant to Section 6 (Make Whole Amount) of Attachment P (Sale of Facility of Seller) or the fair market value determined pursuant to Section 3 (Procedure to Determine Fair Market Value of the Facility) of Attachment P (Sale of Facility by Seller), or (ii) if the sale occurs on or after the beginning of the fourteenth (14th) Contract Year, the fair market value determined pursuant to Section 3 (Procedure to Determine Fair Market Value of the Facility) of Attachment P (Sale of Facility by Seller), but not less than the Financial Termination Costs determined pursuant to Section 6 (Make Whole Amount) of Attachment P (Sale of Facility by Seller), in either case under a Purchase and Sale Agreement to be negotiated based on the terms and conditions set forth in Section 4 (Purchase and Sale Agreement) of Attachment P (Sale of Facility by Seller).

(b) [Reserved]

(c) [Reserved]

ARTICLE 25
GOOD ENGINEERING AND OPERATING PRACTICES

- 25.1 General. Each Party agrees to install, operate and maintain its respective equipment and facility and to perform all obligations required to be performed by such Party under this Agreement in accordance with Good Engineering and Operating Practices and applicable Laws.
- 25.2 Specifications, Determinations and Approvals. Wherever in this Agreement Company has the right to give specifications, determinations or approvals, such specifications, determinations or approvals shall be given in accordance with Company's standard practices, policies and procedures and shall not be unreasonably withheld.
- 25.3 No Endorsement, Warranty or Waiver. Any such specifications, determinations, or approvals shall not be deemed to be an endorsement, warranty, or waiver of any right of Company.
- 25.4 Consultants List. Prior to the Commercial Operations Date, the Parties shall agree on a list of names of engineering firms to be attached as Attachment D (Consultants List) in accordance with Section 4 (Maintenance of Seller-Owned Interconnection Facilities) of Attachment B (Facility Owned by Seller).

ARTICLE 26
EQUAL EMPLOYMENT OPPORTUNITY

- 26.1 Equal Employment Opportunity. (Applicable to all contracts of \$10,000 or more in the whole or aggregate. 41 CFR 60-1.4 and 41 CFR 60-741.5.) Seller is aware of and is fully informed of Seller's responsibilities under Executive Order 11246 (reference to which include amendments and orders superseding in whole or in part) and shall be bound by and agrees to the applicable provisions as contained in Section 202 of said Executive Order and the Equal Opportunity Clause as set forth in 41 CFR 60-1.4 and 41 CFR 60-741.5(a), which clauses are hereby incorporated by reference.
- 26.2 Equal Opportunity For Disabled Veterans, Recently Separated Veterans, Other Protected Veterans and Armed Forces Service Medal Veterans. Applicable to (i) contracts of \$25,000 or more entered into before December 31, 2003 (41 CFR 60-250.4) or (ii) each federal government contract of \$100,000 or more, entered into or modified on or after December 31, 2003 (41 CFR 60-300.4) for the purchase, sale or use of personal property or nonpersonal services (including construction.) If applicable to Seller under this Agreement, Seller agrees that it is, and shall remain, in compliance with the rules and regulations promulgated under The Vietnam Era Veterans Readjustment Assistance Act of 1974, as amended by the Jobs for Veterans Act of 2002, including the requirements of 41 CFC 60-250.5(a) (for orders/contracts entered into before December 31, 2003) and 41 CFR 60-300.5(a) (for orders/contracts entered into or modified on or after December 31, 2003) which are incorporated into this Agreement by reference.

ARTICLE 27
SET OFF

Company shall have the right to set off any payment due and owing by Seller, including but not limited to any payment under this Agreement and any payment due under any award made under Article 28 (Dispute Resolution), against Company's payments of subsequent monthly invoices as necessary.

ARTICLE 28
DISPUTE RESOLUTION

- 28.1 Good Faith Negotiations. Except as otherwise expressly set forth in this Agreement, before submitting any claims, controversies or disputes ("Dispute(s)") under this Agreement to the Dispute Resolution Procedures set forth in Section 28.2 (Dispute Resolution Procedures, Mediation), the presidents, vice presidents, or authorized delegates from both Seller and Company having full authority to settle the Dispute(s), shall personally meet in Hawai'i and attempt in good faith to resolve the Dispute(s) (the "Management Meeting").
- 28.2 Dispute Resolutions Procedures, Mediation. Except as otherwise expressly set forth in this Agreement and subject to Section 28.1 (Good Faith Negotiations), any and all Dispute(s) arising out of or relating to this Agreement, (i) which remain unresolved for a period of 20 Days after the Management Meeting takes place or (ii) for which the Parties fail to hold a Management Meeting within 60 Days of the date that a Management Meeting was requested by a Party, may upon the agreement of the Parties, first be submitted to confidential mediation in Honolulu, Hawai'i pursuant to the administration by, and in accordance with the Mediation Rules, Procedures and Protocols of, Dispute Prevention & Resolution, Inc. (or its successor) or, in their absence, the American Arbitration Association ("DPR") then in effect. If the Parties agree to submit the dispute to confidential mediation, the parties shall each pay 50% of the cost of the mediation (i.e., the fees and expenses charged by the mediator and DPR) and shall otherwise each bear their own mediation costs and attorneys' fees. If the Parties do not submit the Dispute(s) to mediation, or if they do submit the Dispute(s) to mediation but settlement of the Dispute(s) is not reached within 60 Days after commencement of the mediation, either Party may initiate legal proceedings in a court of competent jurisdiction in the State of Hawai'i.
- 28.3 Exclusions. The provisions of this Article 28 (Dispute Resolution) shall not apply to any disputes within the authority of any of (i) an Independent Evaluator under Article 23 (Process for Addressing Revisions to Performance Standards), (ii) an Independent AF Evaluator under Attachment T (Monthly Reporting and Dispute Resolution by Independent AF Evaluator) or (iii) an OEPR Evaluator under

Attachment U (Calculation and Adjustment of Net Energy Potential).

- 28.4 Document Retention. If either party initiates dispute resolution under this Article 28 (Dispute Resolution), then each Party must retain and preserve all records, including documents, which may be relevant to such Dispute, in accordance with applicable Laws until such Dispute is resolved.

ARTICLE 29
MISCELLANEOUS

29.1 Amendments. Any amendment or modification of this Agreement or any part hereof shall not be valid unless in writing and signed via manual signature by the Parties. Any waiver hereunder shall not be valid unless in writing and signed via manual signature by the Party against whom waiver is asserted. Notwithstanding the foregoing, administrative changes mutually agreed by Company and Seller in writing, such as changes to settings shown in Attachment E (Single-Line Drawing and Interface Block Diagram) and Attachment F (Relay List and Trip Scheme) and changes to numerical values of Performance Standards in Section 3 (Performance Standards) of Attachment B (Facility Owned by Seller) shall not be considered amendments to this Agreement requiring PUC approval.

29.2 Binding Effect. This Agreement shall be binding upon and inure to the benefit of the Parties hereto and their respective successors, legal representatives, and permitted assigns.

29.3 Notices.

(a) All notices, consents and waivers under this Agreement shall be in writing and will be deemed to have been duly given when (i) delivered by hand, (ii) sent by electronic mail ("E-mail") (provided receipt thereof is confirmed via E-mail or in writing by recipient), (iii) sent by certified mail, return receipt requested, or (iv) when received by the addressee, if sent by a nationally recognized overnight delivery service (receipt requested), in each case to the appropriate addresses and E-mail Addresses set forth below (or to such other addresses and E-mail addresses as a Party may designate by notice to the other Party):

Company:

By Mail:

Delivered By Hand or Overnight Delivery:

By E-mail:

With a copy to:

By Mail:

Hawaiian Electric Company, Inc.
Legal Division
P.O. Box 2750
Honolulu, Hawai'i 96840

By E-mail:

Hawaiian Electric Company, Inc.
Legal Division
Email: legalnotices@hawaiianelectric.com

Seller: The contact information listed in Attachment A (Description of Generation, Conversion and Storage Facility) hereto.

- (b) Notice sent by mail shall be deemed to have been given on the date of actual delivery or at the expiration of the fifth Day after the date of mailing, whichever is earlier. Any Party hereto may change its address for written notice by giving written notice of such change to the other Party hereto.
- (c) Any notice delivered by E-mail shall request a receipt thereof confirmed by E-mail or in writing by the recipient and followed by personal or mail delivery of such correspondence any attachments as may be requested by the recipient, and the effective date of such notice shall be the date of receipt, provided such receipt has been confirmed by the recipient.

- (d) The Parties may agree in writing upon additional means of providing notices, consents and waivers under this Agreement in order to adapt to changing technology and commercial practices.
- 29.4 Effect of Section and Attachment Headings. The Table of Contents and paragraph headings of the various sections and attachments have been inserted in this Agreement as a matter of convenience for reference only and shall not modify, define or limit any of the terms or provisions hereof and shall not be used in the interpretation of any term or provision of this Agreement.
- 29.5 Non-Waiver. Except as otherwise provided in this Agreement, no delay or forbearance of Company or Seller in the exercise of any remedy or right will constitute a waiver thereof, and the exercise or partial exercise of a remedy or right shall not preclude further exercise of the same or any other remedy or right.
- 29.6 Relationship of the Parties. Nothing in this Agreement shall be deemed to constitute either Party hereto as partner, agent or representative of the other Party or to create any fiduciary relationship between the Parties. Seller does not hereby dedicate any part of Facility to serve Company, Company's customers or the public.
- 29.7 Entire Agreement. This Agreement and the IRS Letter Agreements (together with any confidentiality or non-disclosure agreements entered into by the Parties during the process of negotiating this Agreement and/or discussing the specifications of the Facility) constitutes the entire agreement between the Parties relating to the subject matter hereof, superseding all prior agreements, understandings or undertakings, oral or written. Each of the Parties confirms that in entering into this Agreement, it has not relied on any statement, warranty or other representations (other than those set out in this Agreement) made or information supplied by or on behalf of the other Party.
- 29.8 Governing Law, Jurisdiction and Venue. Interpretation and performance of this Agreement shall be in accordance with, and shall be controlled by, the laws of the State of Hawai'i, other than the laws thereof that would require reference to the laws of any other jurisdiction. By entering into this Agreement, Seller submits itself to the personal jurisdiction of the courts of the State of Hawai'i

and agrees that the proper venue for any civil action arising out of or relating to this Agreement shall be Honolulu, Hawai'i.

- 29.9 Limitations. Nothing in this Agreement shall limit Company's ability to exercise its rights as specified in Company's Tariff as filed with the PUC, or as specified in General Order No. 7 of the PUC's Standards for Electric Utility Service in the State of Hawai'i, as either may be amended from time to time.
- 29.10 Further Assurances. If either Party determines in its reasonable discretion that any further instruments, assurances or other things are necessary or desirable to carry out the terms of this Agreement, the other Party will execute and deliver all such instruments and assurances and do all things reasonably necessary or desirable to carry out the terms of this Agreement.
- 29.11 Electronic Signatures and Counterparts. The parties agree that this Agreement and any subsequent writings, including amendments, may be executed and delivered by exchange of executed copies via E-mail or other acceptable electronic means, and in electronic formats such as Adobe PDF or other formats mutually agreeable between the parties which preserve the final terms of this Agreement or such writing. A party's signature transmitted by facsimile, E-mail, or other acceptable electronic means shall be considered an "original" signature which is binding and effective for all purposes of this Agreement. This Agreement may be executed in counterparts, each of which shall be deemed an original, and all of which shall together constitute one and the same instrument binding all Parties notwithstanding that all of the Parties are not signatories to the same counterparts. For all purposes, duplicate unexecuted and unacknowledged pages of the counterparts may be discarded and the remaining pages assembled as one document.
- 29.12 Definitions. Capitalized terms used in this Agreement and not otherwise defined in the context in which they first appear are defined in the Definitions Section.
- 29.13 Severability. If any term or provision of this Agreement, or the application thereof to any person, entity or circumstances is to any extent invalid or unenforceable, the remainder of this Agreement, or the application of such term or provision to persons, entities or circumstances other

than those as to which it is invalid or unenforceable, shall not be affected thereby, and each term and provision of this Agreement shall be valid and enforceable to the fullest extent permitted by law, and the Parties will take all commercially reasonable steps, including modification of the Agreement, to preserve the economic "benefit of the bargain" to both Parties notwithstanding any such aforesaid invalidity or unenforceability.

- 29.14 Settlement of Disputes. Except as otherwise expressly provided, any dispute or difference arising out of this Agreement or concerning the performance or the non-performance by either Party of its obligations under this Agreement shall be determined in accordance with the dispute resolution procedures set forth in Article 28 (Dispute Resolution) of this Agreement.
- 29.15 Environmental Credits and RPS. To the extent not prohibited by law, Company shall have the sole and exclusive right to use the electric energy purchased hereunder to meet RPS and any Environmental Credit shall be the property of Company; provided, however, that such Environmental Credits shall be to the benefit of Company's ratepayers in that the value must be credited "above the line". Seller shall use all commercially reasonable efforts to ensure such Environmental Credits are vested in Company, and shall execute all documents, including, but not limited to, documents transferring such Environmental Credits, without further compensation; provided, however, that Company agrees to pay for all reasonable costs associated with such efforts and/or documentation.
- 29.16 Schedule of Defined Terms and Attachments. The Schedule of Defined Terms and each Attachment to this Agreement constitute essential and necessary parts of this Agreement.
- 29.17 Proprietary Rights. Seller agrees that in fulfilling its responsibilities under this Agreement, it will not use any process, program, design, device or material that infringes on any United States patent, trademark, copyright or trade secret ("Proprietary Rights"). Seller agrees to indemnify, defend and hold harmless the Indemnified Company Party from and against all losses, damages, claims, fees and costs, including but not limited to reasonable attorneys' fees and costs, arising from or incidental to any suit or proceeding brought against the Indemnified Company Party for

infringement of Third Party Proprietary Rights arising out of Seller's performance under this Agreement, including but not limited to patent infringement due to the use of technical features of the Facility to meet the Performance Standards specified in the Agreement.

29.18 Negotiated Terms. The Parties agree that the terms and conditions of this Agreement are the result of negotiations between the Parties and that this Agreement shall not be construed in favor of or against any Party by reason of the extent to which any Party or its professional advisors participated in the preparation of this Agreement.

29.19 Computation of Time. In computing any period of time prescribed or allowed under this Agreement, the Day of the act, event or default from which the designated period of time begins to run shall not be included. If the last Day of the period so computed is not a Business Day, then the period shall run until the end of the next Day which is a Business Day.

29.20 PUC Approval.

(a) PUC Approval Order. The term "PUC Approval Order" means an order from the PUC that does not contain terms and conditions deemed to be unacceptable by Company, and is in a form deemed to be reasonable by Company, in its sole, but nonarbitrary, discretion, ordering that:

- (1) this Agreement is approved;
- (2) Company is authorized to include the purchased energy costs (and related revenue taxes) that Company incurs under this Agreement in Company's Energy Cost Recovery Clause, or equivalent, to the extent such costs are not included in Base Rates for the Term;
- (3) Company is authorized to include the Lump Sum Payment that Company incurs under this Agreement in Company's Purchase Power Adjustment Clause, to the extent such costs are not included in Base Rates for the Term;
- (4) the purchased energy costs and the Lump Sum Payment to be incurred by Company as a result of this Agreement are reasonable; and

- (5) Company's purchased power arrangements under this Agreement, pursuant to which Company will purchase [energy and **(Only if PPA has energy payment)**] renewable dispatchable generation from Seller, are prudent and in the public interest.
- (b) Non-appealable PUC Approval Order. The term "Non-appealable PUC Approval Order" means a PUC Approval Order (i) that is not subject to appeal to any Circuit Court of the State of Hawai'i, Intermediate Court of Appeals of the State of Hawai'i, or the Supreme Court of the State of Hawai'i, because the period permitted for such an appeal (the "Appeal Period") has passed without the filing of notice of such an appeal, or (ii) that was affirmed on appeal to any Circuit Court of the State of Hawai'i, Intermediate Court of Appeals of the State of Hawai'i, or the Supreme Court of the State of Hawai'i, or was affirmed upon further appeal or appellate process, and that is not subject to further appeal, because the jurisdictional time permitted for such an appeal and/or further appellate process such as a motion for reconsideration or an application for writ of certiorari has passed without the filing of notice of such an appeal or the filing for further appellate process.
- (c) Company's Written Statement. Not later than thirty-five (35) Days after the issuance of a PUC order approving this Agreement, Company shall provide Seller with a copy of such order together with a written statement as to whether the conditions set forth in Section 29.20(a) (PUC Approval Order) have been met and the order constitutes a PUC Approval Order. If Company's written statement declares that the conditions set forth in Section 29.20(a) (PUC Approval Order) have been satisfied, the date of the issuance of the PUC Approval Order shall be the "PUC Approval Order Date".
- (d) Non-appealable PUC Approval Order Date. If Company provides the written statement referred to in Section 29.20(c) (Company's Written Statement) to the effect that the conditions referred to in Section 29.20(a) (PUC Approval Order) have been satisfied, the term "Non-appealable PUC Approval Order Date" shall be defined as follows:

- (1) If a PUC Approval Order is issued and is not made subject to a motion for reconsideration or clarification filed with the PUC or an appeal, the Non-appealable PUC Approval Order Date shall be the date one Day after the expiration of the Appeal Period following the issuance of the PUC Approval Order, or the date of Company's written statement as required under Section 29.20(c) (Company's Written Statement), whichever is later;
 - (2) If the PUC Approval Order became subject to a motion for reconsideration or clarification, and the motion for reconsideration or clarification is denied or the PUC Approval Order is affirmed after reconsideration or clarification, and such order is not made subject to an appeal, the Non-appealable PUC Approval Order Date shall be deemed to be the date one Day after the expiration of the Appeal Period following the order denying reconsideration of or clarification of, or affirming, the PUC Approval Order; or
 - (3) If the PUC Approval Order, or an order denying reconsideration or clarification of the PUC Approval Order or affirming approval of the PUC Approval Order after reconsideration or clarification, becomes subject to an appeal, then the Non-appealable PUC Approval Order Date shall be the date upon which the PUC Approval Order becomes a non-appealable order within the meaning of the definition of a Non-Appealable PUC Approval Order in Section 29.20(b) (Non-appealable PUC Approval Order).
- (e) Unfavorable PUC Order. The term "Unfavorable PUC Order" means an order from the PUC concerning this Agreement that: (i) dismisses Company's application; (ii) denies Company's application; or (iii) approves Company's application but contains terms and conditions deemed unacceptable by Company in its sole discretion and therefore does not meet the definition of a PUC Approval Order as set forth in Section 29.20(a) (PUC Approval Order).

29.21 Community Outreach.

- (a) The Parties acknowledge that, prior to the Execution Date, Seller provided to Company a comprehensive community outreach and communications plan to work with and inform neighboring communities and stakeholders to gain their support for the Project ("Community Outreach and Engagement Plan"). Seller agrees to work with neighboring communities and stakeholders and provide them timely information during all phases of the Project, including but not limited to the following information: Project description, Project stakeholders, community concerns and Seller's efforts to address such concerns, Project benefits, government approvals, Project schedule, and a Community Outreach and Engagement Plan. Seller's Community Outreach and Engagement Plan is a public document and shall remain available to members of the community on the Seller's website for the Term of this Agreement and upon request. Seller shall also provide Company with links to its Project website and Community Outreach and Engagement Plan.
- (b) The Parties also acknowledge that, prior to the Execution Date, Seller provided reasonable advance notice and hosted a public meeting for community and neighborhood groups in and around the vicinity of the Project site that provided neighboring community, stakeholders, and the general public with: (i) a reasonable opportunity to learn about the proposed Project; (ii) an opportunity to engage in a dialogue about concerns, mitigation measures, and potential community benefits of the proposed Project; and (iii) information concerning the process and/or intent for the public's input and engagement, including advising attendees that they will have thirty (30) Days from the date of said public meeting to submit written comments to Company and/or Seller for inclusion in the Company's submission to the PUC of its application for a satisfactory PUC Approval Order. Seller shall collect all public comments, and then provide Company copies of all comments received in their original, unedited form, along with copies of all comments with personal information redacted and ready for filing. Seller agrees that Company may submit any and all public comments (presented in its original, unedited form) as part of its PUC application for this Project.

- (c) Seller acknowledges and agrees that subsequent to the PUC Submittal Date and prior to the date when the Parties' statements of position are to be filed in the docketed PUC proceeding for this Project, Seller will solicit public comments concerning the Project a second time. Seller will submit to the PUC as part of the docketed PUC proceeding for this Project, any and all public comments (presented in its original, unedited form) received by Company and/or Seller regarding the Project that are not received in time to include as part of the Company's application for a satisfactory PUC Approval Order.
- (d) The Parties acknowledge and agree that Seller is responsible for community outreach and engagement for the Project, and that the public meeting and comment solicitation process described in this Section 29.21 (Community Outreach) do not represent the only community outreach and engagement activities that can or should be performed by Seller. Without limitation to the generality of the preceding sentence, Seller agrees to take into account the Project's potential impacts on historical and cultural resources and, at a minimum, Seller shall describe: (i) any valued cultural, historical, or natural resources in the area in question, including the extent to which traditional and customary native Hawaiian rights are exercised in the area; (ii) the extent to which those resources - including traditional and customary native Hawaiian rights - will be affected or impaired by the Project; and (iii) the feasible action, if any, to be taken to reasonably protect native Hawaiian rights if they are found to exist. Seller shall determine and implement such additional means as may be reasonably necessary to share information with and involve the community and neighborhood groups in and around the vicinity of the Facility during the Project planning and development process through the Term of this Agreement, and shall timely inform Company of its plans and activities in this regard.
- (e) Upon the Execution Date and at all times during the Term of this Agreement, Seller shall designate an individual as the "Seller's Community Representative." The Seller's Community Representative shall be the primary contact between the community and the Seller and shall

be available during the Term of this Agreement to receive and answer questions from the community. As of the Execution Date, the Seller's Community Representative shall be:

Name: [name of Seller's Community Representative]

Contact Information: [email address]

Seller shall notify Company in writing upon designation of any new Seller's Community Representative.

29.22 Change in Standard System or Organization.

- (a) Consistent With Original Intent. If, during the Term, any standard, system or organization referenced in this Agreement should be modified or replaced in the normal course of events, such modification or replacement shall from that point in time be used in this Agreement in place of the original standard, system or organization, but only to the extent such modification or replacement is generally consistent with the original spirit and intent of this Agreement.
- (b) Eliminated or Inconsistent With Original Intent. If, during the Term, any standard system or organization referenced in this Agreement should be eliminated or cease to exist, or is modified or replaced and such modification or replacement is inconsistent with the original spirit and intent of this Agreement, then in such event the Parties will negotiate in good faith to amend this Agreement to a standard, system or organization that would be consistent with the original spirit and intent of this Agreement.

29.23 No Third Party Beneficiaries. Nothing expressed or referred to in this Agreement will be construed to give any person or entity other than the Parties any legal or equitable right, remedy, or claim under or with respect to this Agreement or any provision of this Agreement. This Agreement and all of its provisions and conditions are for the sole and exclusive benefit of the Parties and their successors and permitted assigns.

29.24 Hawai'i General Excise Tax. Seller shall, when making payments to Company under this Agreement, pay such additional amount as may be necessary to reimburse Company

for the Hawai'i general excise tax on gross income and all other similar taxes imposed on Company by any Governmental Authority with respect to payments in the nature of gross receipts tax, sales tax, privilege tax or the like (including receipt of any payment made under this Section 29.24 (Hawai'i General Excise Tax)), but excluding federal or state net income taxes. By way of example and not limitation, as of the Execution Date, all payments subject to the Hawai'i general excise tax plus surcharge on Hawai'i island (totaling 4.5% as of the Execution Date) would include an additional 4.7120% so that the underlying payment will be net of such tax liability.

29.25 Survival of Obligations. The rights and obligations that are intended to survive a termination of this Agreement are all of those rights and obligations that this Agreement expressly provides shall survive any such termination and those that arise from Seller's or Company's covenants, agreements, representations, and warranties applicable to, or to be performed, at or during any time prior to or as a result of the termination of this Agreement, including, without limitation:

- (a) The obligation to pay Daily Delay Damages under Section 13.4 (Damages and Termination);
- (b) The obligation to pay Termination Damages under Article 16 (Damages in the Event of Termination by Company);
- (c) The indemnity obligations under Article 17 (Indemnification) and Section 29.17 (Proprietary Rights);
- (d) The dispute resolution provisions of Article 28 (Dispute Resolution);
- (e) Section 29.3 (Notices), Section 29.5 (Non-Waiver), Section 29.8 (Governing Law, Jurisdiction and Venue), Section 29.9 (Limitations), Section 29.13 (Severability), Section 29.14 (Settlement of Disputes), Section 29.15 (Environmental Credits and RPS), Section 29.17 (Proprietary Rights), Section 29.19 (Computation of Time), Section 29.23 (No Third Party Beneficiaries), Section 29.24 (Hawai'i General Excise Tax), Section 29.25 (Survival of Obligations), Section 7 (Land Restoration) of Attachment G (Company-Owned Interconnection Facilities) and Section 1(d) (Seller's

Right to Transfer) and Section 2(d) (Right of First Refusal) of Attachment P (Sale of Facility by Seller); and

- (f) Seller's obligations under Section 3 (Seller Payment To Company for Company-Owned Interconnection Facilities and Review Of Facility) of Attachment G (Company-Owned Interconnection Facilities) to pay interconnection costs and Section 4 (Ongoing Operation and Maintenance Charges) of Attachment G (Company-Owned Interconnection Facilities) to pay operation and maintenance costs incurred up to the date of termination of the Agreement.

29.26 Certain Rules of Construction. For purposes of this Agreement:

- (a) "Including" and any other words or phrases of inclusion will not be construed as terms of limitation, so that references to "included" matters will be regarded as non-exclusive, non-characterizing illustrations.
- (b) "Copy" or "copies" means that the copy or copies of the material to which it relates are true, correct and complete.
- (c) When "Article," "Section," "Schedule," or "Attachment" is capitalized in this Agreement, it refers to an article, section, schedule or attachment to this Agreement.
- (d) "Will" has the same meaning as "shall" and, thus, connotes an obligation and an imperative and not a futurity.
- (e) Titles and captions of or in this Agreement, the cover sheet and table of contents of this Agreement, and language in parenthesis following Section references are inserted only as a matter of convenience and in no way define, limit, extend or describe the scope of this Agreement or the intent of any of its provisions.
- (f) Whenever the context requires, the singular includes the plural and plural includes the singular, and the gender of any pronoun includes the other genders.

(g) Any reference to any statutory provision includes each successor provision and all applicable Laws as to that provision.

29.27 Agreement is Not a Design or Construction Contract. This Agreement is not a design or construction contract. The Parties acknowledge and agree that Seller will finance and develop the Facility for Seller to own and operate. Seller is not a design professional or a contractor. Seller is not hereby undertaking to perform and is not holding itself out or offering to perform any work for which a professional or contractor's license may be required under the laws of the State of Hawai'i. Notwithstanding anything to the contrary, all work related to the design, engineering, and construction of the Facility shall be performed by design professionals and contractors who hold the appropriate licenses issued by the State of Hawai'i and intend to develop the Facility in full compliance with all applicable state laws. For the avoidance of doubt, in all instances where this Agreement refers to Seller performing the acts of constructing, building or installing, said language shall be interpreted to mean that such work will be performed by duly licensed contractors properly retained by Seller in accordance with laws of the State of Hawai'i.

**[Signatures for PPA for Renewable Dispatchable Generation
appear on the following page]**

IN WITNESS WHEREOF, Company and Seller have executed this Agreement as of the day and year first above written.

HAWAI'I ELECTRIC LIGHT COMPANY, INC.

By _____
Name:
Its:

By _____
Name:
Its:

("Company")

[NAME OF PROJECT ENTITY]

By _____
Name:
Its:

By _____
Name:
Its:

("Seller")

SCHEDULE OF DEFINED TERMS

For the purposes of this Agreement, the following capitalized terms shall have the meanings set forth below:

"Acceptance Notice": Shall have the meaning set forth in Section 1(a)(ii) of Attachment P (Sale of Facility by Seller) to this Agreement.

"Acceptance Test": A test conducted by Seller and witnessed by Company, within thirty (30) Days of completion of all Interconnection Facilities and in accordance with criteria and test procedures determined by Company and Seller as set forth in Section 2(f) (Acceptance Test Procedure) of Attachment G (Company-Owned Interconnection Facilities), to determine conformance with Article 3 (Facility Owned and/or Operated by Seller) and Attachment G (Company-Owned Interconnection Facilities) and Good Engineering and Operating Practices. Attachment N (Acceptance Test General Criteria) provides general criteria to be included in the written protocol for the Acceptance Test. Successful completion of the Acceptance Test shall be a condition precedent for the performance of the Control System Acceptance Test and the Commercial Operations Date.

"Active Power Control Interface": Shall have the meaning set forth in Section 1(g) (Active Power Control Interface) of Attachment B (Facility Owned by Seller) of this Agreement.

"Actual Output": The total quantity of electric energy (measured in kilowatt hours) produced by the Facility over a given time period and delivered to the Point of Interconnection, as measured by the revenue meter. "Actual Output" is the equivalent of "Net Energy."

"Agreement": Shall have the meaning set forth in the preamble to this Agreement.

"Allowed Capacity": Shall have the meaning set forth in Section 5(e) of Attachment A (Description of Generation, Conversion and Storage Facility) to this Agreement.

"Appeal Period": Shall have the meaning set forth in Section 29.20(b) (Non-appealable PUC Approval Order) of this Agreement.

"Applicable Period Lump Sum Payment": For each applicable period, the total amount of Lump Sum Payment payable during such period,

as such amount may be calculated and adjusted from time to time as set forth in Section 2.3 (Lump Sum Payment) of this Agreement and/or Section 3 (Calculation of Lump Sum Payment) of Attachment J (Company Payments for Energy, Dispatchability and Availability of BESS) to this Agreement, including but not limited to any downward adjustment made pursuant to Section 3.iv of said Attachment J (Company Payments for Energy, Dispatchability and Availability of BESS), but excluding any set-off of liquidated damages under Section 2.12 (Payment of Liquidated Damages for Failure to Achieve Performance Metrics; Limitation on Liquidated Damages). For purposes of calculating liquidated damages under Section 2.5(b) (PV System Equivalent Availability Factor Performance Metric and Liquidated Damages), the "Applicable Period Lump Sum Payment" is the monthly Lump Sum Payment payable for the last calendar month of the LD Period in question. For purposes of calculating liquidated damages under Section 2.6(c) (GPR Performance Metric and Liquidated Damages), the "Applicable Period Lump Sum Payment" is the monthly Lump Sum Payments payable for the last calendar month of the MPR Assessment Period in question. For purposes of calculating liquidated damages under Section 2.7(a) (BESS Capacity Test and Liquidated Damages), Section 2.8(a) (BESS Annual Equivalent Availability Factor and Liquidated Damages) and Section 2.9 (BESS Annual Equivalent Forced Outage Factor; Liquidated Damages) and Section 2.10(a) (RTE Test and Liquidated Damages), the "Applicable Period Lump Sum Payment" is the total of the monthly Lump Sum Payments payable for the three months of the BESS Measurement Period in question.

"Applicable NEP Verification Date": For the Initial OEPR, the Initial NEP Verification Date. For any Subsequent OEPR, the first Day of the calendar month following the calendar month during which there occurs the first anniversary of the event (e.g., completion of equipment replacement) which occasioned the preparation of such Subsequent OEPR.

"Appraised Fair Market Value of the Facility": Shall have the meaning set forth in Section 3(d) of Attachment P (Sale of Facility by Seller) to this Agreement.

"Battery Energy Storage System" or "BESS": The battery energy storage system as described in Section 5 (Equipment) of Attachment A (Description of Generation, Conversion and Storage Facility) to this Agreement, together with all other equipment, devices, and associated appurtenances owned, controlled, operated and managed by Seller in connections, with or to facilitate, the storage,

transmission, delivery or furnishing by Seller to Company of the electric energy stored in the BESS.

"BESS Allocated Portion of the Lump Sum Payment": For each BESS Measurement Period and for any other applicable period, an amount equal to fifty percent (50%) of the total of the three monthly Lump Sum Payments for such period without taking into account any set-offs against such monthly Lump Sum Payments.

"BESS Annual Equivalent Availability Factor": Shall be as described in Attachment X (BESS Annual Equivalent Availability Factor) to this Agreement.

"BESS Annual Equivalent Forced Outage Factor": Shall have the meaning set forth in Attachment Y (BESS Annual Equivalent Forced Outage Factor) to this Agreement.

"BESS Capacity Performance Metric": Shall have the meaning set forth in Attachment W (BESS Tests) to this Agreement.

"BESS Capacity Cure Period": Shall have the meaning set forth in Section 2.7(b) (BESS Capacity Test Termination Rights).

"BESS Capacity Ratio": Shall have the meaning set forth in Attachment W (BESS Tests) to this Agreement.

"BESS Capacity Test": Shall have the meaning set forth in Attachment W (BESS Tests) to this Agreement.

"BESS Contract Capacity": The storage capacity, in MWh, of the BESS, or MWh.

"BESS EAF Performance Metric": Shall have the meaning set forth in Section 2.8(a) (BESS Annual Equivalent Availability Factor and Liquidated Damages).

"BESS EFOF Performance Metric": Shall have the meaning set forth in Section 2.9 (BESS Annual Equivalent Forced Outage Factor; Liquidated Damages).

"BESS Measurement Period": Shall mean, in any Contract Year, the following periods of three calendar months each: (i) the period beginning on the first day of the first calendar month of such Contract Year and extending through the last day of the third calendar month of such Contract Year; (ii) the period beginning on the first day of the fourth calendar month of such Contract Year

and extending through the last day of the sixth calendar month of such Contract Year; (iii) the period beginning on the first day of the seventh calendar month of such Contract Year and extending through the last day of the ninth calendar month of such Contract Year; and (iv) the period beginning on the first day of the tenth calendar month of such Contract Year and extending through the last day of the twelfth calendar month of such Contract Year.

"BESS Measurement Period Report": For each BESS Measurement Period, the report of the data necessary for calculation of the Performance Metrics for such BESS Measurement Period to be provided by Seller to Company in the form set forth in Section 1 (Monthly Report) of Attachment T (Monthly Reporting and Dispute Resolution by Independent AF Evaluator) to this Agreement or such other form as the Company may approve in writing.

"Bill of Material": A list of equipment to be installed at the Facility including, but not necessarily limited to, items such as relays, breakers, and switches.

"Business Day": Any calendar day that is not a Saturday, a Sunday, or a federal or Hawai'i state holiday.

"Change in Control": Shall have the meaning set forth in Section 1(b) (Change in Ownership Interests and Control of Seller) of Attachment P (Sale of Facility by Seller) to this Agreement.

"Claim": Any claim, suit, action, demand or proceeding.

"Claiming Entity": Shall mean Seller and any direct or indirect owner of a membership interest in Seller which is eligible to claim a Refundable Tax Credit or Non-Refundable Tax Credit in a given year.

"COD Delay LD Period": Shall have the meaning set forth in Section 13.4(a)(2).

"Commercial Operations": Upon satisfaction of the following conditions, the Facility shall be considered to have achieved Commercial Operations on the Day specified in Seller's written notice described below: (i) the Acceptance Test has been passed, (ii) all generating units have passed Control System Acceptance Tests, (iii) the Transfer Date has occurred, (iv) Seller has (1) provided to Company the Required Models (as defined in Section 6(a) (Seller's Obligation to Provide Models) of Attachment B (Facility Owned by Seller)) in the form of Source Code, (2) placed

the current version of the Source Code for the Required Models with the Source Code Escrow Agent as required in Section 6(b)(i)(A) (Establishment of Source Code Escrow) of Attachment B (Facility Owned by Seller), or (3) if Seller is unable to arrange for the placement of the appropriate Source Code into the Source Code Escrow account, placed the required funds with the Monetary Escrow Agent as required in Section 6(b)(ii)(A) (Establishment of Monetary Escrow) of Attachment B (Facility Owned by Seller), and (v) Seller provides Company with written notice that (aa) Seller is ready to declare the Commercial Operations Date and (bb) the Commercial Operations Date will occur within 24 hours (i.e., the next Day).

"Commercial Operations Date" or "COD": The date on which Facility first achieves Commercial Operations.

"Company": Shall have the meaning set forth in the preamble to this Agreement.

"Company-Designated NEP Estimate": The estimated Net Energy Potential of the Facility as designated by Company pursuant to Section 1(c) (NEP IE Estimate and Company-Designated NEP Estimate) of Attachment U (Calculation and Adjustment of Net Energy Potential) this Agreement.

"Company Dispatch": Company's right, through supervisory equipment or otherwise, to direct or control both the capacity and the energy output of the Facility from its minimum output rating to its maximum output rating consistent with this Agreement (including, without limitation, Good Engineering and Operating Practices and the requirements set forth in Section 3 (Performance Standards) of Attachment B (Facility Owned by Seller) to this Agreement), which dispatch shall include real power, reactive power, voltage, frequency, the determination to cycle a unit off-line or to restart a unit, the droop control setting, the ramp rate setting, and other characteristics of such electric energy output whose parameters are normally controlled or accounted for in a utility dispatching system.

"Company Milestones": Each of the milestones identified as such in Attachment K-1 (Seller's Conditions Precedent and Company Milestones).

"Company-Owned Interconnection Facilities": Shall have the meaning set forth in Section 1(a) (General) of Attachment G (Company-Owned Interconnection Facilities).

"Company System": The electric system owned and operated by Company (to include any non-utility owned facilities) consisting of power plants, transmission and distribution lines, and related equipment for the production and delivery of electric power to the public.

"Company System Operator": The authorized representative of Company who is responsible for carrying out Company dispatch and curtailment of electric energy generation interconnected to the Company System.

"Company's Recommendations": Shall have the meaning set forth in Section 4(c) of Attachment B (Facility Owned by Seller) to this Agreement.

"Competitive Bidding Framework": The Framework for Competitive Bidding contained in Decision and Order No. 23121 issued by the Public Utilities Commission on December 8, 2006, and any subsequent orders providing for modifications from those set forth in Order No. 23121 issued December 8, 2006.

"Construction Delay LD Period": Shall have the meaning set forth in Section 13.4(a)(1).

"Construction Financing Closing Milestone": Shall have the meaning set forth in Attachment K (Guaranteed Project Milestones).

"Construction Milestones": The Reporting Milestones set forth in Attachment L (Reporting Milestones) and the Guaranteed Project Milestones set forth in Attachment K (Guaranteed Project Milestones).

"Consultants List": Shall have the meaning set forth in Section 4(e) of Attachment B (Facility Owned by Seller) to this Agreement.

"Consumer Advocate": Shall have the meaning set forth in Section 24.2 (Confidentiality).

"Contract Capacity": Shall have the meaning set forth in Section 5(b) of Attachment A (Description of Generation, Conversion and Storage Facility) to this Agreement.

"Contract Pricing": The total of the Energy Payment and the Lump Sum Payment.

"Contract Year": A twelve (12) calendar month period commencing on either: (i) the Commercial Operations Date (if the Commercial Operations Date occurs on the first Day of a calendar month) and thereafter on each anniversary of the Commercial Operations Date; or (ii) the first Day of the calendar month following the month during which the Commercial Operations Date occurs, and thereafter on each anniversary of the first Day of such month; provided, however, that, in the latter case, the initial Contract Year shall also include the Days from the Commercial Operations Date to the first Day of the succeeding calendar month.

"Contractors": Shall have the meaning set forth in Section 2(a)(i) of Attachment G (Company-Owned Interconnection Facilities) to this Agreement.

"Control System Acceptance Test(s)" or "CSAT": A test or tests performed on the centralized and collective control systems and Active Power Control Interface of the Facility, which includes successful completion of the Control System Telemetry and Control List, in accordance with procedures set forth in Section 1(h) (Control System Acceptance Test Procedures) of Attachment B (Facility Owned by Seller). Attachment O (Control System Acceptance Test Criteria) provides general criteria to be included in the written protocol for the Control System Acceptance Test.

"Control System Telemetry and Control List": The Control System Telemetry and Control List includes, but is not limited to, all of the Facility's equipment and generation performance/quality parameters that will be monitored, alarmed and/or controlled by Company's Energy Management System (EMS) throughout the Term of this Agreement.

Examples of the Control System Telemetry and Control List include:

- Seller's substation/equipment status - breaker open/closed status, equipment normal/alarm operating status, etc.
- Seller's generation data (analog values) - number of generators available/online, voltage, current, MW, MVAR, etc.
- Seller's generation performance (status and/or analog values) - ramp rate, generator frequency, etc.
- Active Power control interface - dispatch MW setpoint, etc.

- Voltage control interface - voltage kV setpoint, etc.
- Power factor control interface - power factor setpoint, etc.

"Daily Delay Damages": Shall have the meaning set forth in Section 13.4(a) (Daily Delay Damages) of this Agreement.

"Day": A calendar day.

"Defaulting Party": The Party whose failure, action or breach of its obligations under this Agreement results in an Event of Default under Article 15 (Events of Default) of this Agreement.

"Development Period Security": An amount equal to \$50/kW of the Contract Capacity.

"Disconnection Event": Shall have the meaning set forth in Section 4(a) of Attachment B (Facility Owned by Seller) to this Agreement.

"Dispute": Shall have the meaning set forth in Section 28.1 (Good Faith Negotiations).

"DPR": Shall have the meaning set forth in Section 28.2 (Dispute Resolution Procedures, Mediation).

"E-mail": Shall have the meaning set forth in Section 29.3 (Notices).

"Effective Date": Shall mean the last to occur of (i) the Non-appealable PUC Approval Order Date and (ii) the date that the Interconnection Requirements Amendment (if required pursuant to Section 12.4(a) of this Agreement) is executed and delivered as such date is set forth in the Interconnection Requirements Amendment.

"EMS" or "Energy Management System": The real-time, computer-based control system, or any successor thereto, used by Company to manage the supply and delivery of electric energy to its consumers. It provides the Company System Operator with an integrated set of manual and automatic functions necessary for the operation of the Company System under both normal and emergency conditions. The EMS provides the interfaces for the Company System Operator to perform real-time monitoring and control of the Company System, including but not limited to monitoring and control of the Facility for system balancing, supplemental

frequency control and economic dispatch as prescribed in this Agreement.

"Energy Cost Recovery Clause": The provision in Company's rate schedules that allows Company to pass through to its customers Company's costs of fuel and purchased power.

"Energy Payment": The amount that Company will pay Seller for electric energy delivered to Company in accordance with the terms and conditions of this Agreement on a monthly basis as set forth in Attachment J (Company Payments for Energy, Dispatchability and Availability of BESS) to this Agreement.

"Engineering and Design Work": Shall have the meaning set forth in Section 3(a) (Seller Payment to Company) of Attachment G (Company-Owned Interconnection Facilities).

"Environment": Shall have the meaning set forth in Section 1(b)(iii)(G)(ii) (Malware) of Attachment B (Facility Owned by Seller) to this Agreement.

"Environmental Credits": Any environmental credit, offset, or other benefit allocated, assigned or otherwise awarded by any Governmental Authority, international agency, or non-governmental renewable energy certificate accounting and verification organization to Company or Seller based in whole or in part on the fact that the Facility is a non-fossil fuel facility. Such Environmental Credits shall include, without limitation, the non-energy attributes of renewable energy including, but not limited to, any avoided emissions of pollutants to the air, soil, or water such as sulfur dioxide, nitrogen oxides, carbon monoxide, particulate matter, and hazardous air pollutants; any other pollutant that is now or may in the future be regulated under the pollution control laws of the United States; and avoided emissions of carbon dioxide and any other greenhouse gas, along with the renewable energy certificate reporting rights to these avoided emissions, but in all cases shall not mean tax credits.

"EPC Contractor": Shall mean Seller's engineering, procurement and construction contractor for the Facility.

"Escrow Agent": Shall have the meaning set forth in Section 14.9 (L/C Proceeds Escrow).

"Event of Default": Shall have the meaning set forth in Article 15 (Events of Default) of this Agreement.

"Excess Energy Conditions": An operating condition on the Company System that may occur when Company has more energy available than is required to meet the load on the Company System at any point in time and the generating assets interconnected with the Company System are operating at or near their minimum levels, taking into consideration factors such as the need to maintain system reliability and stability under changing system conditions and configurations, the need for downward regulating reserves, the terms and conditions of power purchase agreements for base-loaded firm capacity or scheduled energy, and the normal minimum loading levels of such units.

"Exclusive Negotiation Period": Shall have the meaning set forth in Section 2(b) (Negotiations) of Attachment P (Sale of Facility by Seller) to this Agreement.

"Execution Date": The date designated as such on the first page of this Agreement or, if no date is so designated, the date the Parties exchanged executed signature pages to this Agreement.

"Exempt Sales": Shall have the meaning set forth in Section 1(c) (Exempt Sales) of Attachment P (Sale of Facility by Seller) to this Agreement.

"Extended Term": Shall have the meaning set forth in Section 12.1 (Term) of this Agreement.

"Facility": Seller's renewable electric energy facility that is the subject of this Agreement, including the PV System, the BESS, all Seller-Owned Interconnection Facilities and all other equipment, devices, associated appurtenances owned, controlled, operated and managed by Seller in connection with, or to facilitate, the production, generation, storage, transmission, delivery or furnishing of electric energy by Seller to Company and required to interconnect with the Company System.

"Facility Debt": The obligations of Seller and its affiliates to any lender pursuant to the Financing Documents, including without limitation, principal of, premium and interest on indebtedness, fees, expenses or penalties, amounts due upon acceleration, prepayment or restructuring, swap or interest rate hedging breakage costs and any claims or interest due with respect to any of the foregoing.

"Facility Lender": Any lender(s) or tax equity financing party providing any Facility Debt and any successor(s) or assigns thereto, collectively.

"FASB": Shall have the meaning set forth in Section 24.1 (Financial Compliance).

"FASB ASC 810": Shall have the meaning set forth in Section 24.1 (Financial Compliance).

"Fast Frequency Response Performance Metric": Shall have the meaning set forth in Section 2.11 (Fast Frequency Response Performance Metric) of this Agreement.

"Federal Non-Refundable Tax Credit": Shall mean any U.S. federal tax credit for which the federal government is not required to refund any tax credit which exceeds the tax payments due to the federal government by the Claiming Entity or to provide a cash rebate in lieu of such credit to the Claiming Entity.

"Federal Refundable Tax Credit": Shall mean any U.S. federal tax credit for which the federal government is required to refund any tax credit which exceeds the tax payments due to the federal government by the Claiming Entity or to provide a cash rebate in lieu of such credit to the Claiming Entity.

"FFR Allocated Portion of the Lump Sum Payment": An amount equal to [REDACTED] percent ([REDACTED]%) of the monthly Lump Sum Payment amount without taking into account any set-offs against such monthly Lump Sum Payment. **[DRAFTING NOTE: PERCENTAGE SHALL BE THE PROPORTIONATE RELATIONSHIP BETWEEN THE ANNUAL LUMP SUM PAYMENT SPECIFIED IN SELLER'S RESPONSE TO RFP AND THE ANNUAL COST OF THE CONTINGENCY STORAGE COMPONENT SPECIFIED IN SELLER'S RESPONSE TO RFP FOR THE CONTINGENCY STORAGE VARIATION INCLUDED IN THE PPA.]**

"Final Non-appealable Order from the PUC": Shall have the meaning set forth in Section 5(d) of Attachment P (Sale of Facility by Seller) to this Agreement.

"Financial Compliance Information": Shall have the meaning set forth in Section 24.1 (Financial Compliance).

"Financial Termination Costs": Shall have the meaning set forth in Section 6 (Make Whole Amount) of Attachment P (Sale of Facility by Seller) to this Agreement.

"Financing Documents": The loan and credit agreements, notes, bonds, indentures, security agreements, lease financing agreements, mortgages, deeds of trust, interest rate exchanges, swap agreements and other documents relating to the development, bridge, construction and/or permanent debt financing for the Facility, including any credit enhancement, credit support, working capital financing, tax equity financing or refinancing documents, and any and all amendments, modifications, or supplements to the foregoing that may be entered into from time to time by and at the discretion of Seller and/or its affiliates in connection with financing for the development, construction, ownership, leasing, operation or maintenance of the Facility.

"Financing Purposes": Shall have the meaning set forth in Section 1(c) (Exempt Sales) of Attachment P (Sale of Facility by Seller) to this Agreement.

"First Benchmark Period": The period commencing on the Commercial Operations Date and ending on the last Day of the calendar month during which an OEPR Evaluator issues the Initial OEPR. During the First Benchmark Period, the First NEP Benchmark shall be the estimate of Net Energy Potential that is used to calculate the Lump Sum Payment as provided in Section 3.i (Lump Sum Payment During First Benchmark Period) of Attachment J (Company Payments for Energy, Dispatchability and Availability of BESS) to this Agreement.

"First NEP Benchmark": The estimate of Net Energy Potential that is used to calculate the Lump Sum Payment during the First Benchmark Period as provided in Section 3.i (Lump Sum Payment During First Benchmark Period) of Attachment J (Company Payments for Energy, Dispatchability and Availability of BESS) to this Agreement. The "First NEP Benchmark" shall consist of whichever of the following is applicable as of the Commercial Operation Date, as more fully provided in Section 1(c) (NEP IE Estimate and Company-Designated NEP Estimate) and Section 1(d) (NEP IE Estimate, Liquidated Damages and Seller's Null and Void Right) of Attachment U (Calculation and Adjustment of Net Energy Potential) to this Agreement: (i) NEP RFP Projection, (ii) NEP IE Estimate, (iii) Company-Designated NEP Estimate or (iv) such other amount as the Parties may agree in writing.

"First OEPR": Shall have the meaning set forth in Section 4(f) (Timeline and Fees) of this Attachment U (Calculation and Adjustment of Net Energy Potential) to this Agreement.

"Force Majeure": An event that satisfies the requirements of Section 21.1 (Definition of Force Majeure), Section 21.2 (Events That Could Qualify as Force Majeure) and Section 21.3 (Exclusions From Force Majeure).

"Full Dispatch": A time period during which all inverters are available and there are no technical restrictions or limitations affecting generation imposed to meet Company Dispatch.

"GAAP": Shall have the meaning set forth in Section 24.5(a) (Consolidation).

"Good Engineering and Operating Practices": The practices, methods and acts engaged in or approved by a significant portion of the electric utility industry for similarly situated U.S. facilities, considering Company's isolated island setting, that at a particular time, in the exercise of reasonable judgment in light of the facts known or that reasonably should be known at the time a decision is made, would be expected to accomplish the desired result in a manner consistent with law, regulation, reliability for an island system, safety, environmental protection, economy and expedition. With respect to the Facility, Good Engineering and Operating Practices include, but are not limited to, taking reasonable steps to ensure that:

- (a) Adequate materials, resources and supplies, are available to meet the Facility's needs under normal conditions and reasonably foreseeable abnormal conditions.
- (b) Sufficient operating personnel are available and are adequately experienced and trained to operate the Facility properly, efficiently and within manufacturer's guidelines and specifications and are capable of responding to emergency conditions.
- (c) Preventive, routine and non-routine maintenance and repairs are performed on a basis that ensures reliable long-term and safe operation, and are performed by knowledgeable, trained and experienced personnel utilizing proper equipment, tools, and procedures.
- (d) Appropriate monitoring and testing is done to ensure equipment is functioning as designed and to provide assurance that equipment will function properly under

both normal and reasonably foreseeable abnormal conditions.

- (e) Equipment is operated in a manner safe to workers, the general public and the environment and in accordance with equipment manufacturer's specifications, including, without limitation, defined limitations such as temperature, current, frequency, polarity, synchronization, control system limits, etc.

"Governmental Approvals": All permits, licenses, approvals, certificates, entitlements and other authorizations issued by Governmental Authorities, as well as any agreements with Governmental Authorities, required for the construction, ownership, operation and maintenance of the Facility and the Company-Owned Interconnection Facilities, and all amendments, modifications, supplements, general conditions and addenda thereto.

"Governmental Authority": Any federal, state, local or municipal governmental body; any governmental, quasi-governmental, regulatory or administrative agency, commission, body or other authority exercising or entitled to exercise any administrative, executive, judicial, legislative, policy, regulatory or taxing authority or power; or any court or governmental tribunal.

"GPR": Shall have the meaning set forth in Section 2.4(a) (Design, Operation and Maintenance to Achieve Required Performance Metrics; Charging of BESS).

"GPR Performance Metric": Shall be as determined under Section 2.6(b) (Determination of GPR Performance Metric) of this Agreement.

"Guaranteed Commercial Operations Date": The date specified as such in Attachment K (Guaranteed Project Milestones) of this Agreement, by which Seller guarantees that it will achieve the Commercial Operations Date.

"Guaranteed Procurement Payment Date": The date specified in Attachment K (Guaranteed Project Milestones) that Seller shall make payment to Company of the amount required under Section 3(b)(iii) (Balance of Company-Owned Interconnection Facilities Prepayment) of Attachment G (Company-Owned Interconnection Facilities).

"Guaranteed Project Milestone": Each of the milestone events identified in Attachment K (Guaranteed Project Milestones) of this Agreement.

"Guaranteed Project Milestone Date": Each of the milestone dates identified in Attachment K (Guaranteed Project Milestones) of this Agreement.

"Hawai'i Investment Tax Credit": Shall mean a credit against Hawai'i source income for which Seller is eligible on the Commercial Operations Date or thereafter because of investment in renewable energy technologies incorporated into the Facility.

"Hawai'i Non-Refundable Tax Credit": Shall mean any Hawai'i Investment Tax Credit for which the State of Hawai'i is not required to refund any tax credit which exceeds the tax payments due to the State of Hawai'i by the Claiming Entity or to provide a cash rebate in lieu of such credit to the Claiming Entity.

"Hawai'i Production Tax Credit": Shall mean a credit against Hawai'i source income for which Seller is eligible on the Commercial Operations Date or thereafter because of the energy produced by the Facility.

"Hawai'i Refundable Tax Credit": Shall mean any Hawai'i Investment Tax Credit for which the State of Hawai'i is required to refund any tax credit which exceeds the tax payments due to the State of Hawai'i by the Claiming Entity or to provide a cash rebate in lieu of such credit to the Claiming Entity.

"Hawai'i Renewable Energy Tax Credit": The Hawai'i Investment Tax Credit and the Hawai'i Production Tax Credit.

"HEI": Shall have the meaning set forth in Section 19.7 (Assignment By Company).

"HERA": The Hawai'i Electricity Reliability Administrator.

"HERA Law": Act 166 (Haw. Leg. 2012), which was passed by the 27th Hawai'i Legislature in the form of S.B. No. 2787, S.D. 2, H.D.2, C.D.1 on May 2, 2012 and signed by the Governor on June 27, 2012. The effective date for the law is July 1, 2012. The HERA Law authorizes (i) the PUC to develop, adopt, and enforce reliability standards and interconnection requirements, (ii) the PUC to contract for the performance of related duties with a party that will serve as the HERA, and (iii) the collection of a Hawai'i

electricity reliability surcharge to be collected by Hawai'i's electric utilities and used by the HERA. Reliability standards and interconnection requirements adopted by the PUC pursuant to the HERA Law will apply to any electric utility and any user, owner, or operator of the Hawai'i electric system. The PUC also is provided with the authority to monitor and compel the production of data, files, maps, reports, or any other information concerning any electric utility, any user, owner or operator of the Hawai'i electric system, or other person, business, or entity, considered by the commission to be necessary for exercising jurisdiction over interconnection to the Hawai'i electric system, or for administering the process for interconnection to the Hawai'i electric system.

"IE Energy Assessment Report": The bankable energy assessment report (including but not limited to an assessment of the Facility's Net Energy Potential) prepared for the Facility Lender by an independent engineer as part of the Facility Lender's due diligence leading up to the Facility Lender's legally binding commitment to provide a specific amount of financing for the Project as evidenced by the Facility Lender's execution of the Financing Documents.

"Indemnified Company Party": Shall have the meaning set forth in Section 17.1(a) (Indemnification Against Third Party Claims) of this Agreement.

"Indemnified Seller Party": Shall have the meaning set forth in Section 17.2(a) (Indemnification Against Third Party Claims) of this Agreement.

"Independent Evaluator": A person empowered, pursuant to Section 23.5 (Failure to Reach Agreement) and Section 23.10 (Dispute) of this Agreement, to resolve disputes due to failure of the Parties to agree on a Performance Standards Revision Document.

"Independent AF Evaluator": A person empowered, pursuant to Section 2(e) (Appointment of Independent AF Evaluator) of Attachment T (Monthly Reporting and Dispute Resolution by Independent AF Evaluator) to resolve disagreements due to failure of the Parties to resolve a Monthly Report Disagreement.

"Independent Tax Expert": Shall mean a person (i) with experience and knowledge in the field of tax equity project finance for utility-scale electric generating facilities and in the field of

the Hawai'i Renewable Energy Tax Credit and (ii) who is neutral, impartial and not predisposed to favor either Party.

"Initial NEP OEPR Estimate": The NEP OEPR Estimate set forth in or derived from the Initial OEPR, as more fully set forth in Section 4(e) (Terms of Engagement) of Attachment U (Calculation and Adjustment of Net Energy Potential) to this Agreement.

"Initial NEP Verification Date": The first Day of the calendar month following the fifteenth (15th) calendar month after the Commercial Operations Date.

"Initial OEPR": The OEPR to be prepared pursuant in Section 2 (Initial OEPR) of Attachment U (Calculation and Adjustment of Net Energy Potential) to this Agreement.

"Initial Term": Shall have the meaning set forth in Section 12.1 (Term).

"Interconnection Facilities": The equipment and devices required to permit the Facility to operate in parallel with, and deliver electric energy to, the Company System and provide reliable and safe operation of, and power quality on, the Company System (in accordance with applicable provisions of the PUC's General Order No. 7, Company tariffs, operational practices, interconnection requirements studies, and planning criteria), such as, but not limited to, transmission and distribution lines, transformers, switches, and circuit breakers.

"Interconnection Requirements Amendment": Shall have the meaning set forth in Section 12.4(a) of this Agreement.

"Interconnection Requirements Study" or "IRS": A study, performed in accordance with the terms of the IRS Letter Agreements to determine, among other things, (a) the system requirements and equipment requirements to interconnect the Facility with the Company System, (b) the Performance Standards for the Facility, and (c) an estimate of interconnection costs and project schedule for interconnection of the Facility.

"IRS Letter Agreements": The system impact study and Facility study letter agreements and any written, signed amendments thereto, between Company and Seller that collectively describe the scope, schedule, and payment arrangements for the Interconnection Requirements Study.

"Interface Block Diagram": The visual representation of the signals between Seller and Company, including but not limited to, Telemetry and Control points, digital fault recorder settings, telecommunications and protection signals.

"kV": Kilovolt.

"kW": Kilowatt. Unless expressly provided otherwise, all kW values stated in this Agreement are alternating current values and not direct current values.

"Land Rights": All easements, rights of way, licenses, leases, surface use agreements and other interests or rights in real estate.

"Laws": All federal, state and local laws, rules, regulations, orders, ordinances, permit conditions and other governmental actions.

"L/C Proceeds": Shall have the meaning set forth in Section 14.8 (Failure to Renew or Extend Letter of Credit).

"LD Assessment Date": For the last month of each LD Period, the Day following the expiration of the 10-Business Day period provided for Company to submit a Notice of Disagreement pursuant to Section 2(a) (Notice of Disagreement With Monthly Report) of Attachment T (Monthly Reporting and Dispute Resolution by Independent AF Evaluator) to this Agreement.

"LD Period": A rolling period of twelve (12) calendar months each. At the end of each calendar month, the LD Period rolls forward to include the next calendar month. The initial "LD Period" shall consist of the 12 full calendar months of the initial Contract Year.

"LDT": Shall have the meaning set forth in Section 2.10(a) (RTE Test and Liquidated Damages).

"Losses": Any and all direct, indirect or consequential damages, fines, penalties, deficiencies, losses, liabilities (including settlements and judgments), costs, expenses (including reasonable attorneys' fees and court costs) and disbursements.

"Lowest BESS Capacity Bandwidth": Shall have the meaning set forth in Section 2.7(a) (BESS Capacity Test and Liquidated Damages).

"Lump Sum Payment": The payment to be made by Company to Seller in exchange for Seller making the Net Energy Potential of the Facility available for dispatch by Company. When necessary to account for the availability of some but not all inverters, the amount of the monthly Lump Sum Payment is to be allocated pro rata to each inverter and shall be calculated and adjusted as provided in Section 3 (Calculation of Lump Sum Payment) of Attachment J (Company Payments for Energy, Dispatchability and Availability of BESS) to this Agreement.

"Make Whole Amount": Shall have the meaning set forth in Section 6 (Make Whole Amount) of Attachment P (Sale of Facility by Seller).

"Malware": means computer software, code or instructions that: (a) intentionally, and with malice intent by a third party, adversely affect the operation, security or integrity of a computing, telecommunications or other digital operating or processing system or environment, including without limitation, other programs, data, databases, computer libraries and computer and communications equipment, by altering, destroying, disrupting or inhibiting such operation, security or integrity; (b) without functional purpose, self-replicate without manual intervention; (c) purport to perform a useful function but which actually performs either a destructive or harmful function, or perform no useful function other than utilize substantial computer, telecommunications or memory resources with the intent of causing harm; or (d) without authorization collect and/or transmit to third parties any information or data; including such software, code or instructions commonly known as viruses, Trojans, logic bombs, worms, adware and spyware.

"Management Meeting": Shall have the meaning set forth in Section 28.1 (Good Faith Negotiations).

"Maximum Rated Output": Net maximum output of the BESS in MW, which shall not exceed the Allowed Capacity.

"Measured Performance Ratio" or "MPR": Shall have the meaning set forth in Section 2.6(a) (Calculation of Measured Performance Ratio) of this Agreement.

"MMS": Meteorological monitoring station.

"Monitoring and Communication Equipment": Shall have the meaning set forth in Section 6.2 (Monitoring and Communication Equipment) of this Agreement.

"Monthly Progress Report": Shall have the meaning set forth in Section 13.7 (Monthly Progress Report).

"Monthly Report": The report of the data (for the calendar month and the LD Period, the MPR Assessment Period and the BESS Measurement Period ending with such calendar month) necessary for the calculation of the Performance Metrics to be provided by Seller to Company as set forth in Section 1 (Monthly Report) of Attachment T (Monthly Reporting and Dispute Resolution by Independent AF Evaluator) to this Agreement. Without limitation to the generality of the preceding sentence, references to the Monthly Report for a month that constitutes the last month of a BESS Measurement Period shall be deemed to include the BESS Measurement Period Report for such BESS Measurement Period.

"Monthly Report Disagreement": Any disagreement arising out of the same Monthly Report.

"Most Recent Prior NEP Benchmark": In the event a Subsequent OEPR is prepared for an OEPR Period of Record ending on or after the commencement of the fourth (4th) Contract Year, the "Most Recent Prior NEP Benchmark" shall be (i) for the first such Subsequent OEPR, the Second NEP Benchmark that was used to calculate the Lump Sum Payment for the last month of the Second Benchmark Period pursuant to Section 3.iii.a of Attachment J (Company Payments for Energy, Dispatchability and Availability of BESS) to this Agreement and (ii) for all Subsequent OEPRs prepared after the aforementioned first Subsequent OEPR, the NEP OEPR Estimate obtained from the immediately preceding Subsequent OEPR.

"MPR": Shall have the meaning set forth in Section 2.6(a)(i) of this Agreement.

"MPR Assessment Period": Shall mean, for purposes of demonstrating a Measured Performance Ratio, a rolling period of twelve (12) calendar months each. At the end of each calendar month, the MPR Assessment Period rolls forward to include the next calendar month. The initial "MPR Assessment Period" shall consist of the 12 full calendar months of the initial Contract Year.

"MPR Assessment Period Lump Sum Payment": For each MPR Assessment Period, the monthly Lump Sum Payment for the twelfth month of such

MPR Assessment Period after deducting the amounts (if any) payable as liquidated damages under Section 2.5(b) (PV System Equivalent Availability Factor Performance Metric and Liquidated Damages) for the same calendar month in question.

"MPR Test": Shall have the meaning set forth in Section 2.6(a)(v) (MPR Test) of this Agreement.

"MW": Megawatt. Unless expressly provided otherwise, all MW values stated in this Agreement are alternating current values and not direct current values.

"NEP IE Estimate": The estimated Net Energy Potential of the Facility to which the IE Energy Assessment Report assigns a P-Value of 95 for a ten-year period.

"NEP OEPR Estimate": For each OEPR, the estimated Net Energy Potential of the Facility to which such OEPR assigns a P-Value of 95 for a ten-year period.

"NEP RFP Projection": The Net Energy Potential of the Facility to which the Seller in Seller's RFP Proposal assigns a P-Value of 95 for a ten-year period.

"NERC GADS": Shall have the meaning set forth in Section 2.4(a) (Design, Operation and Maintenance to Achieve Required Performance Metrics; Charging of BESS).

"Net Amount": Shall mean, with respect to any Hawai'i Renewable Tax Credit, the amount remaining after deducting any documented and reasonable financial, legal, administrative and other costs and expenses of applying for, pursuing, monetizing and receiving the applicable Hawai'i Renewable Tax Credit, payments by (or reserves established for the payment by) Seller and/or its investors on account of federal or state income taxes (at the highest applicable marginal corporate rate) payable with respect to receipt of such Hawai'i Renewable Tax Credit, and all payments to or reserves required by Seller's lenders or other financing parties in connection with the application for or receipt of such Hawai'i Renewable Tax Credit.

"Net Energy": The total quantity of electric energy (measured in kilowatt hours) produced by the Facility over a given time period and delivered to the Point of Interconnection, as measured by the revenue meter. "Net Energy" the equivalent of "Actual Output."

"Net Energy Potential": The estimated single number with a P-Value of 95 for the annual Net Energy that could be produced by the Facility based on the estimated long-term monthly and annual total of such production over a ten-year period. The Net Energy Potential is subject to adjustment as provided in Attachment U (Calculation and Adjustment of Net Energy Potential) to this Agreement, but in no circumstances shall the Net Energy Potential exceed the NEP RFP Projection.

"Non-appealable PUC Approval Order": Shall have the meaning set forth in Section 29.20(b) (Non-appealable PUC Approval Order) of this Agreement.

"Non-appealable PUC Approval Order Date": Shall have the meaning set forth in Section 29.20(d) (Non-appealable PUC Approval Order Date) of this Agreement.

"Non-defaulting Party": Shall have the meaning set forth in Section 15.4 (Rights of Non-Defaulting Party; Forward Contract) of this Agreement.

"Non-performing Party": The Party who is in breach of, or is otherwise failing to perform, its obligations under this Agreement.

"Notice of Disagreement": Shall have the meaning set forth in Section 2(a) (Notice of Disagreement With Monthly Report) of Attachment T (Monthly Reporting and Dispute Resolution by Independent AF Evaluator) to this Agreement.

"OEPR": An Operational Energy Production Report, including the Initial OEPR and each Subsequent OEPR.

"OEPR Conference": Shall have the meaning set forth in Section 4(g) (Review of the First OEPR Evaluator Report) of this Attachment U (Calculation and Adjustment of Net Energy Potential) to this Agreement.

"OEPR Consultants List": The engineering firms listed in Section 4(j) (Acceptable Persons and Entities) of Attachment U (Calculation and Adjustment of Net Energy Potential) to this Agreement, as such list may be expanded or contracted by the Parties as provided in Section 4(b) (Eligibility for Appointment as OEPR Evaluator) of said Attachment U (Calculation and Adjustment of Net Energy Potential) or Section 2(f) (Eligibility for Appointment as Independent AF Evaluator) of Attachment T

(Monthly Reporting and Dispute Resolution by Independent AF Evaluator) to this Agreement.

"OEPR Evaluator": Shall have the meaning set forth in Section 4(a) (Selection of OEPR Evaluator) of Attachment U (Calculation and Adjustment of Net Energy Potential) of this Agreement.

"OEPR Period of Record": For each OEPR, the twelve-month period preceding the Applicable NEP Verification Date for such OEPR.

"Offer Date": Shall have the meaning set forth in Section 1(a)(i) of Attachment P (Sale of Facility by Seller) to this Agreement.

"Offer Materials": Shall have the meaning set forth in Section 1(a)(i) of Attachment P (Sale of Facility by Seller) to this Agreement.

"Offer Notice": Shall have the meaning set forth in Section 1(a)(i) of Attachment P (Sale of Facility by Seller) to this Agreement.

"Offer Price": Shall have the meaning set forth in Section 1(a)(i) of Attachment P (Sale of Facility by Seller) to this Agreement.

"Operating Period Security": Shall have the meaning set forth in Section 14.4 (Operating Period Security).

"P-Value": The probability of exceedance.

"Parties": Seller and Company, collectively.

"Party": Each of Seller or Company.

"Performance Metrics": Each of the PV System Equivalent Availability Factor Performance Metric, the GPR Performance Metric, the BESS Capacity Performance Metric, the BESS EAF Performance Metric, the BESS EFOF Performance Metric, the RTE Performance Metric, and the Fast Frequency Response Performance Metric [**DRAFTING NOTE: This metric only applies if Facility provides fast frequency response**].

"Performance Metrics LDs": Shall have the meaning set forth in Section 2.12(a) (Payment of Liquidated Damages).

"Performance Standards": The various performance standards for the operation of the Facility and the delivery of electric energy from

the Facility to Company specified in Section 3 (Performance Standards) of Attachment B (Facility Owned by Seller), as such standards may be revised from time to time pursuant to Article 23 (Process for Addressing Revisions to Performance Standards) of this Agreement.

"Performance Standards Information Request": A written notice from Company to Seller proposing revisions to one or more of the Performance Standards then in effect and requesting information from Seller concerning such proposed revision(s).

"Performance Standards Modifications": For each Performance Standards Revision, any capital improvements, additions, enhancements, replacements, repairs or other operational modifications to the Facility and/or to changes in Seller's operations or maintenance practices necessary to enable the Facility to achieve the performance requirements of such Performance Standards Revision.

"Performance Standards Pricing Impact": Any adjustment in Contract Pricing necessary to specifically reflect the recovery of the net costs and/or net lost revenues specifically attributable to any Performance Standards Modification necessary to comply with a Performance Standard Revision, which shall consist of the following: (i) recovery of, and return on, any capital investment (aa) made over a cost recovery period starting after the Performance Standards Revision is made effective following a PUC Performance Standards Revision Order through the end of the Initial Term and (bb) based on a proposed capital structure that is commercially reasonable for such an investment and the return on investment is at market rates for such an investment or similar investment); (ii) recovery of reasonably expected net additional operating and maintenance costs; and (iii) an adjustment in pricing necessary to compensate Seller for reasonably expected reductions, if any, in the delivery of electric energy to Company under this Agreement, which shall consist of (yy) an increase in payments necessary to compensate Seller for expected reduced electric energy payments under this Agreement; and (zz) to the extent applicable, an increase in payments necessary to compensate Seller for reasonably expected reductions in receipt of production tax credits (pursuant to Section 45 of the Internal Revenue Code) calculated on an after-tax basis.

"Performance Standards Proposal": A written communication from Seller to Company detailing the following with respect to a proposed Performance Standards Revision: (i) a statement as to

whether Seller believes that it is technically feasible to comply with the Performance Standards Revision and the basis therefor; (ii) the Performance Standards Modifications proposed by Seller to comply with the Performance Standards Revision; (iii) the capital and incremental operating costs of any necessary technical improvements, and any other incremental net operating or maintenance costs associated with any necessary operational changes, and any expected lost revenues associated with expected reductions in electric energy delivered to Company; (iv) the Performance Standards Pricing Impact of such costs and/or lost revenues; (v) information regarding the effectiveness of such technical improvements or operational modifications; (vi) proposed contractual consequences for failure to comply with the Performance Standard Revision that would be commercially reasonable under the circumstances; and (vii) such other information as may be reasonably required by Company to evaluate Seller's proposals. A Performance Standards Proposal may be issued either in response to a Performance Standards Information Request or on Seller's own initiative.

"Performance Standards Revision": A revision, as specified in a Performance Standards Information Request or a Seller-initiated Performance Standards Proposal, to the Performance Standards in effect as of the date of such Request or Proposal.

"Performance Standards Revision Document": A document specifying one or more Performance Standards Revisions and setting forth the changes to the Agreement necessary to implement such Performance Standards Revision(s). A Performance Standards Revision Document may be either a written agreement executed by Company and Seller or as directed by the Independent Evaluator pursuant to Section 23.10 (Dispute) of this Agreement, in the absence of such written agreement.

"Permitted Lien": Shall have the meaning set forth in Section 4 (Purchase and Sale Agreement) of Attachment P (Sale of Facility by Seller) to this Agreement.

"Point of Interconnection" or "POI": The point of delivery of electric energy and/or capacity supplied by Seller to Company, where the Facility owned by the Seller interconnects with the Company System. The Seller shall own and maintain the facilities from the Facility to the Point of Interconnection, excluding any Company-Owned Interconnection Facilities located on the Site. The Company shall own and maintain the facilities from the Point of Interconnection to the Company's system. The Point of

Interconnection will be identified in the IRS and set forth on the Single-Line Drawing and Interface Block Diagram in Attachment E (Single-Line Drawing and Interface Block Diagram).

"Power Possible": The calculated potential maximum power production of the Facility reported in megawatts (MW) at the Point of Interconnection taking into account (i) equipment equivalent availability during the period, (ii) the available energy resource and (iii) the BESS State of Charge. The Power Possible is a telemetered value provided to Company as an analog value (i.e., instantaneous).

"PPA Amendment Deadline": The 75th Day following the date the completed IRS is provided to Seller, or such later date as Company and Seller may agree to by written agreement.

"Prime Rate": The "prime rate" of interest, as published from time to time by The Wall Street Journal in the "Money Rates" section of its Western Edition Newspaper (or the average prime rate if a high and a low prime rate are therein reported). The Prime Rate shall change without notice with each change in the prime rate reported by The Wall Street Journal, as of the date such change is reported. Any such rate is a general reference rate of interest, may not be related to any other rate, may not be the lowest or best rate actually charged by any lender to any customer or a favored rate and may not correspond with future increases or decreases in interest rates charged by lenders or market rates in general.

"Proceeds": Shall have the meaning set forth in Section 6(b)(ii)(C) (Extend Letter of Credit) of Attachment B (Facility Owned by Seller) to this Agreement.

"Proceeds Escrow Agent": Shall mean such escrow agent approved by Company.

"Proceeds Escrow Agreement": Shall mean the escrow agreement between Company and the Proceeds Escrow Agent naming Company as beneficiary thereunder, which agreement shall be acceptable in form and substance to Company.

"Project": The Facility as described in Attachment A (Description of Generation, Conversion and Storage Facility).

"Project Documents": This Agreement, any ground lease or other agreement or instrument in respect of the Site and/or the Land

Rights, all construction contracts to which Seller is or becomes a party thereto, operation and maintenance agreements, and all other agreements, documents and instruments to which Seller is or becomes a party thereto in respect of the Facility, other than the Financing Documents, as the same may be modified or amended from time to time in accordance with the terms thereof.

"Proposed Actions": Shall have the meaning set forth in Section 4(c) of Attachment B (Facility Owned by Seller) to this Agreement.

"Proprietary Rights": Shall have the meaning set forth in Section 29.17 (Proprietary Rights) of this Agreement.

"PSA": Shall have the meaning set forth in Section 4 (Purchase and Sale Agreement) of Attachment P (Sale of Facility by Seller) to this Agreement.

"PUC": Shall have the meaning set forth in the Recitals.

"PUC Approval Order": Shall have the meaning set forth in Section 29.20(a) (PUC Approval Order) of this Agreement.

"PUC Approval Order Date": Shall have the meaning set forth in Section 29.20(c) (Company's Written Statement) of this Agreement.

"PUC Approval Time Period": Shall have the meaning set forth in Section 12.6(b) (Time Period for PUC Approval).

"PUC Order Appeal Period": Shall have the meaning set forth in Section 12.6(b) (Time Period for PUC Approval).

"PUC Performance Standards Revision Order": The decision and order of the PUC approving the application or motion by the Parties seeking (i) approval of the Performance Standards Revision in question and the associated Performance Standards Revision Document, (ii) finding that the impact of the changes to the Contract Pricing on Company's revenue requirements is reasonable, and (iii) approval to include the costs arising out of pricing changes in Company's Energy Cost Recovery Clause (or equivalent).

"PUC RPS Order": Shall have the meaning set forth in Section 3.4(e) (PUC RPS Order).

"PUC Submittal Date": The date of the submittal of Company's complete application or motion for a satisfactory PUC Approval Order pursuant to Section 12.3 (PUC Approval) of this Agreement.

"PUC's Standards": Standards for Small Power Production and Cogeneration in the State of Hawai'i, issued by the Public Utilities Commission of the State of Hawai'i, Chapter 74 of Title 6, Hawai'i Administrative Rules, currently in effect and as may be amended from time to time.

"PV System": The photovoltaic solar electric generating project as more particularly described in Attachment A (Description of Generation, Conversion and Storage Facility).

"PV System Equivalent Availability Factor Performance Metric": Shall have the meaning set forth in Section 2.5(b) (PV System Equivalent Availability Factor Performance Metric and Liquidated Damages).

"Qualified Consultant": Shall have the meaning set forth in Section 4(e) of Attachment B (Facility Owned by Seller) to this Agreement.

"Recipient": Shall have the meaning set forth in Section 24.2 (Confidentiality).

"Renewable Portfolio Standards" or "RPS": The Hawai'i law that mandates that Company and its subsidiaries generate or purchase certain amounts of their net electricity sales over time from qualified renewable resources. The RPS requirements in Hawai'i are currently codified as Hawai'i Revised Statutes (HRS) 269-91 through 269-95.

"Renewable Resource Baseline": The estimated renewable resource potential of the Site for a typical meteorological year. For avoidance of doubt, the purpose of this term is to provide a short-hand characterization of the nature of the renewable resource risk assumed by the Seller under this Agreement in making its Site selection.

"Renewable Resource Variability": The variations, above and below the Renewable Resource Baseline, of the renewable resource actually available at the Site on a moment-to-moment basis. For avoidance of doubt, the purpose of this term is to provide a short-hand characterization of the nature of the renewable resource risk assumed by the Company under this Agreement in agreeing to make fixed payments in an amount calculated on the basis of the Facility's capability to deliver the Net Energy

Potential regardless of whether or not sufficient renewable resource is in fact available at any particular moment.

"Required Model" or "Required Models": Shall have the meaning set forth in Section 6(a) (Seller's Obligation to Provide Models) of Attachment B (Facility Owned by Seller) of this Agreement.

"Reporting Milestones": Each of the milestones identified as such in Attachment L (Reporting Milestones).

"Revenue Metering Package": The revenue meter, revenue metering PTs and CTs, and secondary wiring.

"RFP": Company's Request for Proposals for Variable Renewable Dispatchable Generation and Energy Storage, Island of Hawai'i, issued on [_____], 2019.

"RFP Proposal": The documents and submissions comprising Seller's proposal selected in the Final Award Group in response to the RFP.

"Right of First Negotiation Period": Shall have the meaning set forth in Section 1(a)(ii) of Attachment P (Sale of Facility by Seller) to this Agreement.

"RPS Amendment": Any amendment to the RPS subsequent to Effective Date that revises the definition of "renewable electric energy" under the RPS such that the electric energy delivered from the Facility no longer comes within such revised definition.

"RPS Modifications": Any capital improvements, additions, enhancements, replacements, repairs or other operational modifications to the Facility and/or to changes in Seller's operations or maintenance practices necessary to enable the electric energy delivered from the Facility to come within the revised definition of "renewable electrical energy" resulting from a RPS Amendment.

"RPS Modifications Document": Shall have the meaning set forth in Section 3.4(c) (RPS Modifications Document).

"RPS Pricing Impact": Any adjustment in Contract Pricing necessary to specifically reflect the recovery of the net costs and/or net lost revenues specifically attributable to any RPS Modification, which shall consist of the following: (i) recovery of, and return on, any capital investment (aa) made over a cost recovery period starting after the RPS Modification is made effective following a

PUC RPS Order through the end of the Initial Term and (bb) based on a proposed capital structure that is commercially reasonable for such an investment and the return on investment is at market rates for such an investment or similar investment); (ii) recovery of reasonably expected net additional operating and maintenance costs; and (iii) an adjustment in pricing necessary to compensate Seller for reasonably expected reductions, if any, in the delivery of electric energy to Company under this Agreement, which shall consist of (aa) an increase in payments necessary to compensate Seller for expected reduced electric energy payments under this Agreement; and (bb) to the extent applicable, an increase in payments necessary to compensate Seller for reasonably expected reductions in receipt of production tax credits (pursuant to Section 45 of the Internal Revenue Code) calculated on an after-tax basis.

"RTE Cure Period": Shall have the meaning set forth in Section 2.10(b) (RTE Test Termination Rights).

"RTE Performance Metric": Shall have the meaning set forth in Attachment W (BESS Tests) to this Agreement.

"SCADA" or "Supervisory Control And Data Acquisition" The Company system that provides remote control and monitoring of Company's transmission and sub-transmission systems and enables Company to perform real-time control of equipment in the field and to monitor the conditions and status of the Company System.

"Second Benchmark Period": The period commencing on the first Day of the calendar month following the month during which an OEPR Evaluator issues the Initial OEPR and ending with the expiration of the third (3rd) Contract Year. For avoidance of doubt, the effect of the foregoing definition is that the Second Benchmark Period will follow immediately upon the expiration of the First Benchmark Period.

"Second NEP Benchmark": For each calendar month during the Second Benchmark Period, the estimate of Net Energy Potential to be used during such calendar month to calculate the Lump Sum Payment pursuant to Section 3.ii.a of Attachment J (Company Payments for Energy, Dispatchability and Availability of BESS) to this Agreement. For avoidance of doubt, the Second NEP Benchmark may vary during the Second Benchmark Period as and to the extent provided in said Section 3.ii.a.

"Second NUG Contract": Shall have the meaning set forth in Section 1(e) (Revisions to Costs) of Attachment G (Company-Owned Interconnection Facilities) to this Agreement.

"Second OEPR": Shall have the meaning set forth in Section 4(g) (Review of the First OEPR Evaluator Report) of this Attachment U (Calculation and Adjustment of Net Energy Potential) to this Agreement.

"Second OEPR Evaluator": Shall have the meaning set forth in Section 4(g) (Review of the First OEPR Evaluator Report) of this Attachment U (Calculation and Adjustment of Net Energy Potential) to this Agreement.

"Section 5": Shall have the meaning set forth in Section 5(f) of Attachment A (Description of Generation, Conversion and Storage Facility) to this Agreement.

"Security Funds": Shall have the meaning set forth in Section 14.6 (Security Funds).

"Seller": Shall have the meaning set forth in the preamble to this Agreement.

"Seller-Attributable Non-Generation": Time periods during which the inverter in question (or the Facility as a whole) is not dispatched or is derated or shutdown (or the Facility is disconnected) because of any of the following:

- (i) The Facility's failure to comply with any of the Performance Standards, Good Engineering and Operating Practices, Governmental Approvals, applicable Laws or Seller's other obligations under this Agreement;
- (ii) Seller-Attributable System Conditions;
- (iii) Conditions at or on either side of the Point of Interconnection arising from the acts or omissions of Seller or any of its affiliates, employees, agents, contractors, vendors, materialmen, independent contractors or suppliers of Seller, acting in such capacity for the benefit of Seller ("Seller Representatives"), unless such acts or omissions are themselves excused by reasons of Force Majeure pursuant to Article 21 (Force Majeure) of this Agreement;

- (iv) A disconnection initiated by the Company pursuant to Article 9 (Personnel and System Safety) of this Agreement) that is caused by Seller or any Seller Representatives;
- (v) The Company has reasonably decided that it is inadvisable for such inverter (or the Facility as a whole) to continue normal operations without a further Control System Acceptance Test as provided in Section 7(a) (Testing Requirements) of Attachment B (Facility Owned by Seller);
- (vi) The Facility is deemed to be in Seller-Attributable Non-Generation status under any of the following Sections of Attachment B (Facility Owned by Seller): Section 1(g)(vi), Section 1(j) (Demonstration of Facility) or Section 4(e); and
- (vii) The Facility is shutdown at the direction of Company as provided in Section 6.4 (Shutdown For Lack of Reliable Real Time Data), and such shutdown is caused by Seller or any Seller Representatives.

Each time period of Seller-Attributable Non-Generation shall constitute an Outage or Deration, as applicable.

"Seller-Attributable System Conditions": Conditions on the Company System:

- (i) that result from either (aa) the Facility's generation and delivery of electric power to the Company System or (bb) any condition arising from the acts or omissions of Seller or any Seller Representative, unless such acts or omissions are themselves excused by reasons of Force Majeure pursuant to Article 21 (Force Majeure) of this Agreement; and
- (ii) caused by or attributable to the Facility or Seller or any Seller Representatives that Company reasonably determines to either (xx) be inconsistent with Good Engineering and Operating Practices on the Company System or (yy) jeopardize the safety, reliability or stability of the Company System.

For avoidance of doubt, the Company's inability to dispatch the Facility due to the existence of Excess Energy Conditions on the

Company System shall not constitute Seller-Attributable System Conditions.

"Seller-Owned Interconnection Facilities": The Interconnection Facilities constructed and owned by Seller.

"Seller Affiliate": Shall have the meaning set forth in Section 6(b)(ii)(A) (Establishment of Monetary Escrow) of Attachment B (Facility Owned by Seller) to this Agreement.

"Seller's RPS Modifications Proposal": Shall have the meaning set forth in Section 3.4(a) (Renewable Portfolio Standards).

"Site": The parcel of real property on which the Facility will be constructed and located, together with any Land Rights reasonably necessary for the construction, ownership, operation and maintenance of the Facility. The Site is identified in Attachment A (Description of Generation, Conversion and Storage Facility) to this Agreement.

"Source Code": Shall mean the human readable source code of the Required Models which: (i) will be narrated documentation related to the compilation, linking, packaging and platform requirements and any other materials or software sufficient to enable a reasonably skilled programmer to build, modify and use the code within a commercially reasonable period of time for the purposes of a Source Code Authorized Use; and (ii) can reasonably be compiled by a computer for execution.

"Source Code Authorized Use": Shall have the meaning set forth in Section 6(b)(i)(E) (Authorized Use) of Attachment B (Facility Owned by Seller) of this Agreement.

"Source Code Escrow": Shall mean the escrow established with the Source Code Escrow Agent under the terms of the Source Code Escrow Agreement under which Source Code shall be confidentially deposited by a Source Code Owner for safekeeping and, upon the satisfaction of certain conditions, release to the Company.

"Source Code Escrow Agent": Shall mean Iron Mountain Intellectual Property Management, Inc. or such other similar escrow agent approved by Company.

"Source Code Escrow Agreement": Shall mean a multi-party escrow agreement between Company, Source Code Escrow Agent and any and all Source Code Owners depositing Source Code into the Source Code

Escrow which, among other matters, names Company as beneficiary thereunder, and is otherwise acceptable in form and substance to Company.

"Source Code Owner": Shall mean the developer and/or owner of the Required Models utilizing Source Code authorized to deposit the Source Code with the Source Code Escrow Agent upon the terms of the Source Code Escrow Agreement.

"SOX 404": Shall have the meaning set forth in Section 24.1 (Financial Compliance).

"Standards": Shall have the meaning set forth in Section 2(c) (Plans) of Attachment G (Company-Owned Interconnection Facilities) to this Agreement.

"Standby Letter of Credit": Shall have the meaning set forth in Section 6(a) (Standby Letter of Credit) of Attachment G (Company-Owned Interconnection Facilities) to this Agreement.

"State of Charge": Energy in the BESS stated as a percentage of BESS Contract Capacity.

"Study": Shall have the meaning set forth in Section 4(e) of Attachment B (Facility Owned by Seller) to this Agreement.

"Submission Notice": Shall have the meaning set forth in Section 2(e) (Appointment of Independent AF Evaluator) of Attachment T (Monthly Reporting and Dispute Resolution by Independent AF Evaluator) to this Agreement.

"Subsequent NEP OEPR Estimate": For each Subsequent OEPR, the NEP OEPR Estimate derived from such Subsequent OEPR.

"Subsequent OEPR": Any OEPR prepared pursuant to Section 3 (Subsequent OEPRs) of Attachment U (Calculation and Adjustment of Net Energy Potential) to this Agreement.

"Subsequent Owner": Shall have the meaning set forth in Section 19.4 (Financing Document Requirements).

"Telemetry and Control": The interface between Company's EMS and the physical equipment at the Facility.

"Term": Shall mean, collectively, the Initial Term and the Extended Term (if any).

"Termination Damages": Liquidated damages calculated in accordance with Article 16 (Damages in the Event of Termination by Company) of this Agreement.

"Termination Deadline": The 30th Day following the date the completed IRS is provided to Seller, or such later date as Company and Seller may agree to by a written agreement.

"Third OEPR": Shall have the meaning set forth in Section 4(h) (Review of the Second OEPR Evaluator Report) of this Attachment U (Calculation and Adjustment of Net Energy Potential) to this Agreement.

"Third OEPR Evaluator": Shall have the meaning set forth in Section 4(h) (Review of the Second OEPR Evaluator Report) of this Attachment U (Calculation and Adjustment of Net Energy Potential) to this Agreement.

"Third Party": Any person or entity other than Company or Seller, and includes, but is not limited to, any subsidiary or affiliate of Seller.

"Tier 1 Bandwidth": The Tier 1 bandwidth set forth in Section 2.6(c) (GPR Performance Metric and Liquidated Damages) of this Agreement.

"Tier 2 Bandwidth": The Tier 2 bandwidth set forth in Section 2.6(c) (GPR Performance Metric and Liquidated Damages) of this Agreement.

"Total Actual Interconnection Cost": Actual costs for the Interconnection Facilities, to be designed, engineered and constructed by Company, as provided in Attachment G (Company-Owned Interconnection Facilities) to this Agreement.

"Total Actual Relocation Cost": Shall have the meaning set forth in Section 5(b) of Attachment G (Company-Owned Interconnection Facilities) to this Agreement.

"Total Estimated Interconnection Cost": Estimated costs for the Interconnection Facilities, to be designed, engineered and constructed by Company, as provided in Attachment G (Company-Owned Interconnection Facilities) to this Agreement.

"Total Estimated Relocation Cost": Shall have the meaning set forth in Section 5(a) of Attachment G (Company-Owned Interconnection Facilities) to this Agreement.

"Total Interconnection Cost": Shall have the meaning set forth in Section 3(a)(i) of Attachment G (Company-Owned Interconnection Facilities) to this Agreement.

"Transfer Date": The date, prior to the Commercial Operations Date, upon which Seller transfers to Company all right, title and interest in and to Company-Owned Interconnection Facilities to the extent, if any, that such facilities were constructed by Seller and/or its contractors.

"Unfavorable PUC Order": Shall have the meaning set forth in Section 29.20(e) (Unfavorable PUC Order).

"Unit Price": \$ [REDACTED] per [REDACTED] MWh of Net Energy Potential annually.
[TO BE CALCULATED FROM RESPONSE TO RFP.]

ATTACHMENT A
DESCRIPTION OF GENERATION, CONVERSION AND STORAGE FACILITY

1. Name of Facility:

(a) Location: (TMK No.)

(b) Telephone number (for system emergencies):

(c) E-mail Address:

(d) Contact Information for notices pursuant to Section 29.3 (Notices) of the Agreement:

Mailing Address:

Address for Delivery by Hand or Overnight Delivery:

Email Address:

2. Owner (If different from Seller):

If Seller is not the owner, Seller shall provide Company with a certified copy of a certificate warranting that the owner is a corporation, partnership or limited liability company in good standing with the Hawai'i Department of Commerce and Consumer Affairs which shall be attached hereto as Exhibit A-1 (Good Standing Certificates).

3. Operator:

4. Name of person to whom payments are to be made:

(a) Mailing address:

(b) Hawai'i Gross Excise Tax License number:

5. Equipment:

(a) Type of facility and conversion equipment:

[For example: Small power production facility designated as a Qualifying Facility that produces electric energy using _____.]

(b) Design and capacity

Total Facility Capacity ("Contract Capacity"):

_____ kW

Total Number of Generators:

[number and size of each generator, e.g., one (1) Brand X, 200 kW; one (1) Brand Y, 300 kW]

Description of Equipment:

[For example: Describe the type of energy conversion equipment, capacity, and any special features.]

Individual Unit: **[if more than one generator, list information for each generator]**

	kW	kVAR Consumed	kVAR Produced
<u>Full load</u>			
<u>Startup</u>			

Generator:

Type _____

Rated Power _____ kW

Voltage _____ V, _____ phase

Frequency _____ Hz

Class of Protection _____

Number of Poles _____

Rated Speed _____ rpm

Rated Current _____ A

Rated Power Factor See Exhibit B-2

Batteries

Total Number of Energy Storage Units:

Portion of Facility To Provide Fast Frequency Response:

[DRAFTING NOTE: This section only applies if Facility provides fast frequency response.]

Capacity: _____ MW

Storage: _____ MWH

Other Description(s):

- (c) Single or 3 phase:
- (d) Name of manufacturer:
- (e) Description of Facility SCADA and control system(s)
- (f) The "Allowed Capacity" of this Agreement shall be the lower of (i) Contract Capacity or (ii) the net nameplate capacity (net for export) of the Facility installed by the Commercial Operations Date.
- (g) Seller may propose revisions to this Section 5 (Equipment) of Attachment A (Description of Generation, Conversion and Storage Facility) ("Section 5") for Company's approval prior to commencement of construction, provided, however, that (i) no such revision to this Section 5 shall change the type of Facility or conversion equipment deployed at the Facility from a solar energy conversion facility using photovoltaic equipment; (ii) Seller shall be in compliance with all other terms and conditions of this Agreement; and (iii) such revision(s) shall not change the characteristics of the Facility equipment or the specifications used in the IRS. Any revision to

this Section 5 complying with items (i) through (iii) above shall be subject to Company's prior approval, which approval shall not be unreasonably withheld. If Seller's proposed revision(s) to this Section 5 otherwise satisfies items (i) and (ii) above but not item (iii) such that Company, in its reasonable discretion, determines that a re-study or revision to all or any part of the IRS is required to accommodate Seller's proposed revision(s), Company may, in its sole and absolute discretion, conditionally approve such revision(s) subject to a satisfactory re-study or revision to the IRS and Seller's payment and continued obligation to be liable and responsible for all costs and expenses of re-studying or revising such portions of the IRS and for modifying and paying for all costs and expenses of modification to the Facility, the Company-Owned Interconnection Facilities based on the results of the re-studies or revisions to the IRS. Any changes made to this Attachment A (Description of Generation, Conversion and Storage Facility) or the Agreement as a result of this Section 5(f) of Attachment A (Description of Generation, Conversion and Storage Facility) shall be reflected in a written amendment to the Agreement.

Seller understands and acknowledges that Company's review and approval of Seller's proposed revisions to this Section 5 and any necessary re-studies or revisions to the IRS shall be subject to Company's then-existing time and personnel constraints. Company agrees to use commercially reasonable efforts, under such time and personnel constraints, to complete any necessary reviews, approvals and/or re-studies or revisions to the IRS.

Any delay in completing, or failure by Seller to meet, any subsequent Seller milestones under Article 13 (Guaranteed Project Milestones Including Commercial Operations) as a result of any revision pursuant to this Section 5 by Seller (whether requiring a re-study or revision to the IRS or not) shall be borne entirely by Seller and Company shall not be responsible or liable for any delay or failure to meet any such milestones by Seller.

6. Insurance carrier(s): **[SELLER TO PROVIDE INFORMATION]**

7. If Seller is not the operator, Seller shall provide a copy of the agreement between Seller and the operator which requires the operator to operate the Facility and which establishes the scope of operations by the operator and the respective rights of Seller and the operator with respect to the sale of electric energy from Facility no later than the Commercial Operations Date. In addition, Seller shall provide a certified copy of a certificate warranting that the operator is a corporation, partnership or limited liability company in good standing with the Hawai'i Department of Commerce and Consumer Affairs no later than the Commercial Operations Date.
8. Seller shall provide a certified copy of a certificate warranting that Seller is a corporation, partnership or limited liability company in good standing with the Hawai'i Department of Commerce and Consumer Affairs which shall be attached hereto as Exhibit A-1 (Good Standing Certificates).
9. Seller, owner and operator shall provide Company a certificate and/or description of their ownership structures which shall be attached hereto as Exhibit A-2 (Ownership Structure).
10. In the event of a change in ownership or identity of Seller, owner or operator, such entity shall provide within 30 Days thereof, a certified copy of a new certificate and a revised ownership structure.

EXHIBIT A-1
GOOD STANDING CERTIFICATES

EXHIBIT A-2
OWNERSHIP STRUCTURE

**[ATTACHMENT B WILL BE REVISED TO REFLECT
THE RESULTS OF IRS]**

ATTACHMENT B
FACILITY OWNED BY SELLER

1. The Facility.

(a) Drawings, Diagrams, Lists, Settings and As-Builts.

- (i) Single-Line Drawing, Interface Block Diagram, Relay List, Relay Settings and Trip Scheme. A preliminary single-line drawing (including notes), Interface Block Diagram, relay list, relay settings, and trip scheme of the Facility shall, after Seller has obtained prior written consent from Company, be attached to this Agreement on the Execution Date as Attachment E (Single-Line Drawing and Interface Block Diagram) and Attachment F (Relay List and Trip Scheme). A final single-line drawing (including notes), Interface Block Diagram, relay list and trip scheme of the Facility shall, after having obtained prior written consent from Company, be labeled the "Final" Single-Line Drawing, the "Final" Interface Block Diagram and the "Final" Relay List and Trip Scheme and shall supersede Attachment E (Single-Line Drawing and Interface Block Diagram) and Attachment F (Relay List and Trip Scheme) to this Agreement and shall be made a part hereof on the Commercial Operations Date. After the Commercial Operations Date, no changes shall be made to the "Final" Single-Line Drawing, the "Final" Interface Block Diagram and the "Final" Relay List and Trip Scheme without the prior written consent of Seller and Company. The single-line drawing shall expressly identify the Point of Interconnection of Facility to Company System.
- (ii) As-Builts. Seller shall provide final as-built drawings of the Seller-Owned Interconnection Facilities within 30 Days of the successful completion of the Acceptance Test.
- (iii) Modeling. Seller shall provide the models as set forth in Exhibit B-1.

(iv) No Material Changes. Seller agrees that no material changes or additions to the Facility as reflected in the "Final" Single-Line Drawing (including notes), the "Final" Interface Block Diagram and the "Final" Relay List and Trip Scheme, shall be made without Seller first having obtained prior written consent from Company. The foregoing are subject to changes and additions as part of any Performance Standards Modifications. If Company directs any changes in or additions to the Facility, records and operating procedures that are not part of any Performance Standards Modifications, Company shall specify such changes or additions to Seller in writing, and, except in the case of an emergency, Seller shall have the opportunity to review and comment upon any such changes or additions in advance.

(b) Certain Specifications for the Facility.

(i) Seller shall furnish, install, operate and maintain the Facility including breakers, relays, switches, synchronizing equipment, monitoring equipment and control and protective devices approved by Company as suitable for parallel operation of the Facility with Company System. The Facility shall be accessible at all times to authorized Company personnel.

(ii) The Facility shall include:

[LIST OF THE FACILITY

Examples may include, but are not limited to:

- **Seller-Owned Interconnection Facilities**
- **Substation**
- **Control and monitoring facilities**
- **Transformers**
- **Generating and BESS equipment (as described in Attachment A)**
- **"Lockable" cabinets or housings suitable for the installation of the Company-Owned Interconnection Facilities located on the Site**
- **Relays and other protective devices**

- **Leased telephone line and/or equipment to facilitate microwave communication]**

(iii) The Facility shall comply with the following **[includes excerpts of language that may be requested by Company]**:

- A. Seller shall install a ____ kV gang operated, load breaking, lockable disconnect switch and all other items for its switching station (relaying, control power transformers, high voltage circuit breaker). Bus connection shall be made to a manually and automatically (via protective relays) operated high-voltage circuit breaker. The high-voltage circuit breaker shall be fitted with bushing style current transformers for metering and relaying. Downstream of the high-voltage circuit breaker, a structure shall be provided for metering transformers. From the high-voltage circuit breaker, another bus connection shall be made to another pole mounted disconnect switch, with surge protection.
- B. Seller shall provide within the Seller-Owned Interconnection Facilities a separate, fenced area with separate access for Company. Seller shall provide all conduits, structures and accessories necessary for Company to install the Revenue Metering Package. Seller shall also provide within such area, space for Company to install its communications, supervisory control and data acquisition ("SCADA") equipment (remote terminal unit or equivalent) and certain relaying if necessary for the interconnection. Seller shall also provide AC and DC source lines as specified by Company. Seller shall provide a telephone line for Company-owned meters. Seller shall work with Company to determine an acceptable location and size of the fenced-in area. Seller shall provide an acceptable demarcation cabinet on its side of the fence where Seller and Company wiring will connect/interface.
- C. Seller shall ensure that the Seller-Owned Interconnection Facilities have a lockable

cabinet for switching station relaying equipment. Seller shall select and install relaying equipment acceptable to Company. At a minimum the relaying equipment will provide over and under frequency (81) negative phase sequence (46), under voltage (27), over voltage (59), ground over voltage (59G), over current functions (50/51) and direct transfer trip (if required). The settings shall be consistent with the requirements for over/under frequency and voltage ride-through. Seller shall install protective relays that operate a lockout relay, which in turn will trip the main circuit breaker and not allow it to be reclosed without reset.

D. [RESERVED].

E. Seller's equipment also shall provide at a minimum:

- (i) Interface with Company's Telemetry and Control, or designated communications and control interface, to provide telemetry of electrical quantities such as total Facility net MW, MVar, power factor, voltages, currents, and other quantities as identified by the Company;
- (ii) Interface with Company's Telemetry and Control, or designated communications and control interface, to provide status for circuit breakers, reactive devices, switches, and other equipment as identified by the Company;
- (iii) Interface with Company's Telemetry and Control, or designated communications and control interface, to provide control to incrementally raise and lower the voltage target at the point of regulation operating in automatic voltage regulation control;
- (iv) Interface with Company's Telemetry and Control, or designated communications and control interface, to provide the active

power control requirements of this Agreement. More than one interface may be required if Facility energy components, such as a BESS and variable generation resource are controlled separately by the Company (as in grid-charging BESS);

(v) Interface with Company's Telemetry and Control, or designated communications and control interface, for the Company to specify control system modes of operation and parameters, for remotely configurable parameters and operating states required under this Agreement;

(vi) For Variable Energy Facilities: Interface with Company's Telemetry and Control, or designated communications and control interface, to provide telemetry of equipment availability and meteorological and production data required under Section 8 (Data and Forecasting) of this Attachment B (Facility Owned by Seller) and the Facility's Power Possible.

(vii) Provision for Loss of Telemetry and Control: If Company's Telemetry and Control, or designated communications and control interface, is unavailable, due to loss of communication link, Telemetry and Control failure, or other event resulting in loss of the remote control by Company, provision must be made for Seller to be able to institute via local controls, within 5 minutes (or such other period as Company accepts in writing) of the verbal directive by the Company System Operator, such change in voltage regulation target and real power export or import as directed by the Company System Operator.

F. If Seller adds, deletes and/or changes any of its equipment, or changes its design in a manner that would change the characteristics of the equipment and specifications used in the IRS, Seller shall be required to obtain

Company's prior written approval. If an analysis to revise parts of the IRS is required, Seller shall be responsible for the cost of revising those parts of the IRS, and modifying and paying for the cost of the modifications to the Facility and/or the Company-Owned Interconnection Facilities based on the revisions to the IRS.

G. Critical Infrastructure Protection.

- (i) Documentation. Seller shall submit documentation describing the approach, methodology and design to provide physical and cyber security with its submittal of the design drawings pursuant to Section 1(c) (Design Drawings, Bill of Materials, Relay Settings and Fuse Selection) of Attachment B (Facility Owned by Seller) which shall be at least sixty (60) Days prior to the Acceptance Test.
- The design shall meet industry standards and best practices, as indicated by NERC CIP guidelines and requirements for critical generation facilities. The system shall be designed with the criteria to meet applicable industry standards and guidelines (at the time of this writing, NERC CIP, or any future standard adopted by the industry in its place) compliance requirements and identify areas that are not consistent with NERC CIP guidelines and requirements.
 - The cyber-security documentation shall include a block diagram of the control system with all external connections clearly described.
 - Seller shall provide such additional information as Company may reasonably request as part of a

security posture assessment.

- Company shall be notified in advance when there is any condition that would compromise physical or cyber security, or if any breaches in security, or security incidents are detected.

(ii) Malware. Seller shall (consistent with the following sentence) ensure that no malware or similar items are coded or introduced into any aspect of the Facility, Interconnection Facilities, the Company Systems interfacing with the Facility and Interconnection Facilities, and any of Seller's critical control systems or processes used by Seller to provide energy, including the information, data and other materials delivered by or on behalf of Seller to Company, (collectively, the "Environment"). Seller will continue to review, analyze and implement improvements to and upgrades of its Malware prevention and correction programs and processes that are commercially reasonable and consistent with the then current technology industry's standards and, in any case, not less robust than the programs and processes implemented by Seller with respect to its own information systems. If Malware is found to have been introduced into the Environment, Seller will promptly notify Company and Seller shall take immediate action to eliminate and remediate the effects of the Malware, at Seller's expense. Seller shall not modify or otherwise take corrective action with respect to the Company Systems except at Company's request. Seller will promptly report to Company the nature and status of all Malware elimination and remediation efforts.

(iii) Security Breach. In the event that Seller discovers or is notified of a breach, potential breach of security, or security incident at Seller's Facility or of Seller's systems, Seller shall immediately (i) notify Company of such potential, suspected or actual security breach, whether or not such breach has compromised any of Company's confidential information; (ii) investigate and promptly remediate the effects of the breach, whether or not the breach was caused by Seller; (iii) cooperate with Company with respect to any such breach or unauthorized access or use; (iv) comply with all applicable privacy and data protection laws governing Company's or any other individual's or entity's data; and (v) to the extent such breach was caused by Seller, provide Company with reasonable assurances satisfactory to Company that such breach, potential breach, or security incident shall not recur. Seller shall provide documentation to Company evidencing the length and impact of the breach. Any remediation of any such breach will be at Seller's sole expense.

(iv) Monitoring and Audit. Seller shall provide information on available audit logs and reports relating to cyber and physical and security. Company may audit Seller's records to ensure Seller's compliance with the terms of this Section 1(b)(iii)G (Critical Infrastructure Protection) of this Attachment B (Facility Owned by Seller), provided that Company has provided reasonable notice to Seller and any such records of Seller's will be treated by Company as confidential.

H. Available Power Production.

(i) Variable Energy Systems. Seller's available power production considering equipment and resource availability (Power

Possible) will be determined at any given time using the best-available data and methods for an accurate representation of the amount of active power at the Point of Interconnection.

- (ii) Variable Energy Systems Paired with Storage Operated through a Single Active Power Control Interface. For variable energy systems paired with storage operated through a single active power control interface (i.e., charging indirectly controlled through dispatch), Seller's available power production considering equipment and resource availability and state of charge of the storage (Power Possible) will be determined at any given time using the best-available data and methods for an accurate representation of the amount of active power at the Point of Interconnection. Telemetry will be provided to indicate state of charge, including available estimated duration at the current dispatch given state of charge and forecast production.

- (iii) Storage Directly Controlled by the Company. Seller's available power production considering state of charge (Power Possible) will be supplied as an accurate representation of the amount of maximum and minimum (negative) available active power at the Point of Interconnection and the duration available at the current dispatch. If the Facility allows for allocation of capacity to different modes of operation (i.e., reservation of capacity for regulation or contingency response), then the available capacity in each allocated region shall be reported individually and controlled separately through separately designated dispatch or active power control interface.

- I. For variable resources where Power Possible is derived, in part or in whole, from a measured available variable energy source such as solar or wind: To the extent available, the Parties shall use Seller's real time Power Possible communicated to Company through the SCADA System except to the extent that the Potential Energy does not accurately reflect the actual available active power at the Point of Interconnection (plus or minus 0.1 MW). During those periods of time when the SCADA derived Power Possible is unavailable or does not accurately represent the available power production considering equipment and resource availability, the Parties shall use the best available data obtained through commercially reasonable methods to determine the Power Possible. Follow up actions to resolve the discrepancy will be as provided in Section 1(j) (Demonstration of Facility) of this Attachment B (Facility Owned by Seller).
- J. Seller shall reserve space within the Site for possible future installation of Company-owned meteorological equipment (such as wind speed, direction and relative humidity monitors, SODAR and irradiance monitors) and AC and DC source lines for such equipment as may be required depending on the Facility resource type and location. In the event Company decides to install such meteorological equipment: (i) Seller shall work with Company to determine an acceptable location for such equipment and any associated wiring, interface or other components; and (ii) Company shall pay for the needed equipment, and installation of such equipment, unless otherwise agreed to by the Parties. Company and Seller shall use commercially reasonable efforts to facilitate installation and minimize interference with the operation of the Facility.
- K. The Facility shall, at a minimum, satisfy the wind load and seismic load requirements of the International Building Code and any more stringent requirements imposed under applicable Laws.

- (c) Design Drawings, Bill of Material, Relay Settings and Fuse Selection. Seller shall provide to Company for its review the design drawings, Bill of Material, relay settings and fuse selection for the Facility, and Company shall have the right, but not the obligation, to specify the type of electrical equipment, the interconnection wiring, the type of protective relaying equipment, including, but not limited to, the control circuits connected to it and the disconnecting devices, and the settings that affect the reliability and safety of operation of Company's and Seller's interconnected system. Seller shall provide the relay settings and protection coordination study, including fuse selection and AC/DC Schematic Trip Scheme (part of design drawings), for the Facility to Company during the 60% design. Company, at its option, may, with reasonable frequency, witness Seller's operation of control, synchronizing, and protection schemes and shall have the right to periodically re-specify the settings. Seller shall utilize relay settings prescribed by Company, which may be changed over time as Company System requirements change.
- (d) Disconnect Device. Seller shall provide a manually operated disconnect device which provides a visible break to separate Facility from Company System. Such disconnect device shall be lockable in the OPEN position and be readily accessible to Company personnel at all times.
- (e) Other Equipment. Seller shall install, own and maintain the infrastructure associated with the Revenue Metering Package, including but not limited to all enclosures (meter cabinets, meter pedestals, meter sockets, pull boxes, and junction boxes, along with their grounding/bonding connections), CT/PT mounting structures, conduits and ductlines, enclosure support structures, ground buses, pads, test switches, terminal blocks, isolation relays, telephone surge suppressors, and analog phone lines (one per meter), subject to Company's review and approval.
- (f) Maintenance Plan. Seller shall maintain Seller-Owned Interconnection Facilities in accordance with Good Engineering and Operating Practices.

(g) Active Power Control Interface. **[COMPANY TO REVISE THIS SECTION BASED ON SPECIFICS OF THE PROJECT.]**

- (i) Seller shall provide and maintain in good working order all equipment, computers and software associated with the control system (the "Active Power Control Interface") necessary to interface the Facility active power controls with the Company System Operations Control Center for real power control of the Facility by the Company System Operator.

The detailed design will be tailored to the specific resource type and configuration to achieve the functional requirements of the Facility.

The Active Power Control Interface will be used to control the net real power export (or import, as applicable) from the Facility for load following, system balancing, energy arbitrage, and/or supplemental frequency control as required under this Attachment B (Facility Owned by Seller).

For variable resources paired with storage: The implementation of the Active Power Control Interface will allow the Company System Operator to control the net real power export (or import, as applicable) from the entire Facility, up to Power Possible, remotely from the Company System Operations Control Center through control signals from the Company System Operations Control Center. The Facility will maintain the power level specified by the Company through the variable resource and BESS available energy, subject to the availability of resource and BESS State of Charge.

For facilities with grid charging storage, the Active Power Control interface may also direct the charging/discharging of energy from the BESS.

The Facility real power output (or import, if storage charging is enabled) will automatically adjust to a change in frequency in accordance

with the frequency response requirements provided in this Attachment B (Facility Owned by Seller).

- (ii) Company shall review and provide prior written approval of the design for the Active Power Control Interface to ensure compatibility with Company's centralized control systems and use of Facility available energy and storage capabilities. To ensure such continued compatibility, Seller shall not materially change the approved design without Company's prior review and written approval. This will include design description and parameters for the Seller's control system(s), which determine provision of net real power from the variable resource System (i.e., wind or PV) and/or the BESS storage, and charging of the BESS storage, in response to the Active Power Control signal or signals.
- (iii) The Active Power Control Interface shall include, but not be limited to, a demarcation cabinet, ancillary equipment and software necessary for Seller to connect to Company's Telemetry and Control, located in Company's portion of the Facility switching station which shall provide the control signals to the Facility and send feedback status to the Company System Operations Control Center. The control type shall be analog output (set point) or raise/lower controls and will be established by the Company prior to final design approval.
- (iv) The Active Power Control Interface shall also include provision for feedback points from the Facility indicating when active power target in MW for the Active Power Control signal(s). The Facility shall provide the MW target feedback to the Company SCADA system immediately upon receiving the respective control signal from the Company.
- (v) Seller shall provide to the telemetry interface analogs for the gross production of the energy resource(s) at the Facility (for example, DC or AC MW production of the variable resource generator(s), depending on design; gross DC MW of

the BESS, etc.). Seller shall also provide the total net AC MW production at the Point of Interconnection.

- (vi) The Active Power Control Interface shall provide for remote control of the real power output of the Facility by the Company at all times. If the Active Power Control Interface is unavailable or disabled, the Facility may not export electric energy to Company and the Facility shall be deemed to be in Seller-Attributable Non-Generation status, unless the Company, in its sole discretion, agrees on an alternate means of dispatch. If Seller fails to provide such remote control capability (whether temporarily or throughout the Term), then, notwithstanding any other provision of this Attachment B (Facility Owned by Seller), Company shall have the right to derate or disconnect the entire Facility during those periods that such control capability is not provided and the Facility shall be deemed to be in Seller-Attributable Non-Generation status for such periods.
- (vii) The rate at which the Facility changes net real power in response to the active power control shall not be less than the greater of 2 MW per minute or 10% of the Facility capacity per minute, and shall make available through agreed parameters, such faster ramp as the installed equipment can support. The Facility's Active Power Control Interface will be used by Company to control the rate at which electric energy is changed to achieve the active power limit for load-following and regulation. The Facility will respond to the active power control request immediately with an echo of the set point and measurable change within the 4 second control cycle.
- (viii) The Facility shall accept the following controls related to active power and frequency response to or from the Company centralized control system:
- Power Reference Setpoint from Company (based on the input to the Facility, from the Active Power Control Interface): The

Facility output shall match this setting from the Variable Resource and/or BESS so long as it can be supported by the variable resource and/or BESS State of Charge (Power Possible does not change). This net output should be accurate within +/- 0.1 MW under normal frequency conditions. This setpoint will be modified as appropriate in the controls by the appropriate frequency response consistent with Section 1(g)(xi) (Active Power - Frequency Response (DROOP)), Section 1(g)(xii) (Dynamic Active Power - Frequency Performance), and **[FOR FACILITIES WITH STORAGE]** Section 1(g)(xiii) (Alternate Active Power / Frequency Response Modes) of this Attachment B (Facility Owned by Seller).

- For variable energy resources: The Facility shall include Variable Resource Enable/Disable control. When "Disable" is selected, the Facility shall ramp down, shutdown, and leave offline variable resource generators. When "Enable" is selected, the Facility variable resource generators can start up, ramp up, and remain in normal operations subject to Company active power dispatch.
- From Company: Frequency Response Mode (DROOP, FFR, isochronous) state (where alternate modes of operation are required).
- From Seller:
 - [For Facilities with a BESS and where required]: Capacity allocation to each mode of operation where ability to allocate capacity to different modes of operation is required (e.g., to allocate a portion of capacity to fast frequency response) and telemetered data and controls necessary to determine state of charge and gross MW and Mvar

contribution, etc., operationally required for each segmented use.

- o Power Possible (Available maximum capacity): See above, instantaneous limit for available energy, represents max level the Facility can produce under present resource, BESS State of Charge (if applicable) and equipment conditions. This is used as upper limit for Company Dispatch.
- o For variable energy resources, maximum level the variable generation resources can produce under present variable resource and equipment conditions.
- o Minimum Sustained Limit: Minimum output level the Facility can be reduced to continuously without delay (ecomn). For projects with BESS: If BESS charging from the grid is permitted, and charging capacity is available, this will be a negative value.
- o Minimum Transient Limit (for frequency response, regulation) (lfcmn). For projects with BESS: If BESS charging from the grid is permitted, and charging capacity is available, this will be a negative value.
- o Maximum Dispatchable Ramp Rate: Controlled ramp rate available for controlled changes in output.
- o For projects with a BESS, Seller shall also provide the following:
 - BESS potential (BESS State of Charge and projected number of hours at present dispatch, minimum dispatch, and maximum dispatch).
 - Frequency Response Mode (DROOP, FFR, isochronous) state (where

alternate modes of operation are required).

- Capacity allocation to each mode of operation (to allow FFR and Droop allocation).

(ix) Seller shall not override Company's active power controls without first obtaining specific approval to do so from the Company System Operator unless there is a system emergency. Disabling of the remote Active Power Control shall initiate telemetry notification to the Company.

(x) The requirements of the Active Power Control Interface may be modified as mutually agreed upon in writing by the Parties.

Active Power Communications between Company and Seller

Company will receive and send AGC Set-Point and related data through the communications interface in accordance with Company standards. The data points covered under this Agreement, as described below, may overlap with data requirements described elsewhere.

AGC Data Points to be sent from Seller to Company via SCADA

The following data points will be transmitted via SCADA from Seller to Company and represent Facility level data **[Note: May be modified based on resource type and Facility requirements]**:

<u>Description</u>	<u>Units</u>
AGC Set-Point (echo)	MW
Power demand	MW
Actual power	MW
Power Possible	MW
Actual reactive power	Mvars
Average Voltage	Kv

Variable Generation potential	MW
[Wind only] Number of turbines online and running	Integer
BESS State of Charge	Pct
[PV only] Inverters online	Integer
Facility duration at current output	HRS
AGC Status	Remote/Local
[For facilities with alternate modes of frequency response] Indication of Frequency Response Mode	Integer FFR, Droop, ISOCH

Response times and limitations of Facility in regards to Active Power Control

The following protocols outline the expectations for responding to the AGC Set-Point.

Frequency of Changes. Company may send a new AGC Set-Point to the Facility at up to the AGC control cycle (present 4 seconds).

Range of AGC Set-Point. The range of set point values can be between 0% and 100% of Power Possible. For projects offering grid-charging storage, negative set-point values may be required.

Backup Communications

In the event of an AGC failure, Company and Seller shall communicate via telephone, or other method mutually agreeable between the Parties, in order to correct the failure.

(xi) Active Power - Frequency Response (DROOP).

The Facility shall provide a primary frequency response with a frequency droop characteristic

reacting to system frequency at the Point of Interconnection in both the overfrequency and underfrequency directions except as limited by the minimum and maximum available capacity and energy potential at the time of the event including BESS state of charge. This response must be timely and sustained rather than injected for a short period and then withdrawn. For over-frequency events, response may include absorption through charging (as applicable under the terms of this Agreement). Seller shall provide minimum operational limits for each online resource and the Facility for primary frequency response.

Frequency will be calculated over a period of time (e.g., three to six cycles, or other period as specified by Company), and filtered to take control action on the fundamental frequency component of the calculated signal. Calculated frequency may not be susceptible to spikes caused by phase jumps on the Company system.

The active power-frequency control system, and overall response of the inverter-based resource (plant), must meet the following performance aspects (see figure below):

The active power-frequency control system shall have an adjustable proportional droop characteristic with a default value of [4%] percent. The droop setting shall permit a setting from 0.1% to 10%. This setting shall be changed upon Company's written request as necessary for grid droop response coordination. The droop setting shall be tunable and may be specified during commissioning. The droop shall be a permanent value based on Pmax (maximum nominal active power output of the plant) and Pmin (typically 0 for an inverter based resource). This keeps the proportional droop constant across the full range of operation. The curve for an inverter-based BESS may include the negative active power quadrant of this curve. The droop response must include the capability to respond in both the upward (underfrequency) and downward (overfrequency) directions. Frequency droop will be based on the difference between maximum

nameplate active power output (P_{max}) and zero output (P_{min}) such that the [4%] percent droop line is always constant for a resource.

Seller shall make commercially reasonable efforts to provide frequency response without a deadband, but in any case, not to exceed ± 0.0166 Hz. If the active power-frequency control system has a deadband, it shall be a nonstep deadband that is adjustable between 0 Hz and the full frequency range of the droop characteristic with a default value not to exceed ± 0.036 Hz. (Nonstep deadband is where the change in active power output starts from zero deviation on either side of the deadband.) (Frequency deadband is the range of frequencies in which the unit does not change active power output.)

Inverter-based resources may consider a small hysteresis characteristic where linear droop meets any deadband to reduce dithering of inverter output when operating near the edges of the deadband. The hysteresis range may not exceed ± 0.005 Hz on either side of the deadband. If measurement resolution is not sufficient to measure this frequency, hysteresis may not be used.

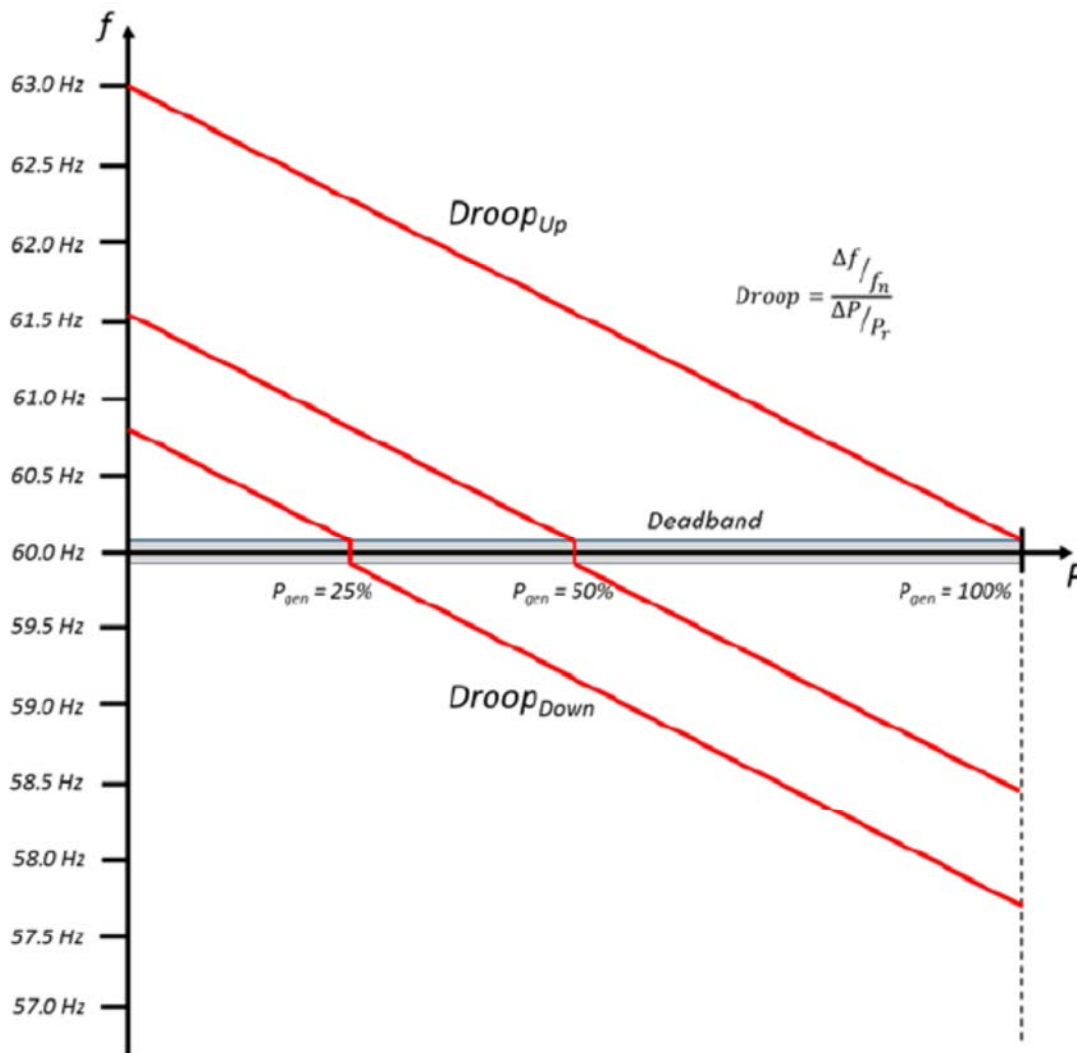

Active Power - Frequency Control Characteristic

Nominal System Frequency is 60.00 Hz.

The closed-loop dynamic response of the active power-frequency control system of the overall inverter-based resources, as measured at the POI must have the capability to meet or exceed the performance specified in below. Seller shall ensure that the models and parameters for the resources and control equipment are consistent with those provided during the IRS process and that any updates have been provided to the Company reflecting currently implemented settings and configuration.

(xii) Dynamic Active Power-Frequency Performance.

For a step change in frequency at the point of measure of the inverter-based resource **[NOTE - MAY BE ADJUSTED AS THE RESULT OF IRS]**:

Reaction time: The time between a step change in frequency and the time when the resource active power output begins responding to the change shall be less than 500 Ms, or as otherwise specified by Company.¹

Rise time: The time when the resource has reached 90% of the new steady-state (target) active power output shall be less than 4 seconds, or as otherwise specified by Company.²

Settling Time: Time in which the resource has entered into, and remains within, the settling band of the new steady-state active power (target) output shall be less than 10 seconds, or as otherwise specified by Company.

Overshoot: Percentage of the rated active power output that the resource can exceed while reaching the settling band shall be less than 5% or as otherwise specified by Company.³

Settling Band: Percentage of rated active power output that the resource should settle to within the settling time shall be less than 2.5%.

When operating in parallel with the Company System, the Facility shall operate with its primary frequency response control in automatic operation and in accordance with Company directions. Notification of changes in the status of the frequency response controls and, where applicable, mode of operation must be provided to the Company System Operator immediately through SCADA telemetry indication.

¹ Time between step change in frequency and the time to 10 percent of new steady-state value can be used as a proxy for determining this time.

² Percentage based on final (expected) settling value.

³ Percentage based on final (expected) settling value.

The Facility frequency response control shall adjust, without intentional delay and without regard to the ramp rate limits in Section 3(c) (Ramp Rates) of this Attachment B (Facility Owned by Seller), the Facility's net real power export based on frequency deadband and frequency droop settings specified by the Company.

The Facility frequency response control shall increase the net real power export above the Power Reference Setpoint set under Section 1(g)(viii) of this Attachment B (Facility Owned by Seller) or further decrease the net real power export from the Power Reference Limit in its operations in accordance with the frequency response settings.

The Facility frequency response control shall be in continuous operation unless directed otherwise by the Company.

(xiii) **[FOR FACILITIES WITH STORAGE]**. Alternate Active Power/ Frequency Response Modes. The Facility will provide the capability to supply isochronous or fast frequency response modes of operation, in addition to normal droop, which can be set remotely or locally. The control design shall allow for a bumpless transfer between modes of operation.

A. Fast Frequency Response (FFR): This mode of operation will permit the Facility to respond to system frequency disturbances with a fast charge/discharge response in accordance with the fast frequency response droop settings. In this mode of operation, the Facility frequency response is configured to provide fast frequency response, as an alternative setting to the normal steady-state frequency response. When in this mode of operation, the frequency droop characteristics are configured to charge or discharge with a different set of parameters to allow for a faster and larger proportional charge and discharge in response to frequency changes outside of the configurable deadband. The initial parameter settings will be specified by Company following the IRS, and additional

tuning and adjustment of configurable parameters may be required based on review of response to actual system events. When in FFR mode, when system frequency is within the fast frequency response deadband, the Facility will operate to maintain a percentage state of charge, which is configurable on Company request (i.e., 50%), managed at a charging/discharging rate also specified by Company.

- (1) When in FFR mode the active power-frequency control system shall have an adjustable FFR proportional droop characteristic with a default value of [1%] percent. The FFR droop setting shall permit a setting from 0.1% to 5%. This setting shall be changed upon Company's written request as necessary for fast frequency response coordination. The FFR droop shall be a permanent value based on Pmax (maximum nominal active power output of the plant) and Pmin (typically 0 for an inverter-based resource). This keeps the proportional droop constant across the full range of operation. The curve for an inverter-based BESS may include the negative active power quadrant of this curve. The droop response must include the capability to respond in both the upward (underfrequency) and downward (overfrequency) directions. Frequency droop will be based on the difference between maximum nameplate active power output (Pmax) and zero output (Pmin) such that the [1%] percent droop line is always constant for a resource.
- (2) When in FFR mode the active power-frequency control system shall have an adjustable frequency deadband with a default value of 0.3 Hz. The deadband setting shall permit a setting from 0.1 Hz to 1 Hz. This setting shall be changed upon Company's written request

as necessary for fast frequency response coordination. The deadband setting shall be tunable and may be specified during commissioning. It shall be a nonstep deadband such that the change in active power output starts from zero deviation on either side of the deadband. (Frequency deadband is the range of frequencies in which the unit does not change active power output.)

- (3) FFR-1 Performance Requirements - Expected FFR Active Power-Frequency Performance. For a step change in frequency at the point of measure of the FFR resource:

Reaction time: The time between a step change in frequency and the time when the resource active power output begins responding to the change shall be less than 50 milliseconds, or as otherwise specified by Company.⁴

Rise time: The time when the resource has reached 90% of the new steady-state (target) active power output shall be less than 0.133 seconds, or as otherwise specified by Company.⁵

Settling Time: Time in which the resource has entered into, and remains within, the settling band of the new steady-state active power (target) output shall be less than 500 milliseconds, or as otherwise specified by Company.

Overshoot: Percentage of the rated active power output that the resource can exceed while reaching the

⁴ Time between step change in frequency and the time to 10 percent of new steady-state value can be used as a proxy for determining this time.

⁵ Percentage based on final (expected) settling value.

settling band shall be less than 5% or as otherwise specified by Company.⁶

Settling Band: Percentage of rated active power output that the resource should settle to within the settling time shall be less than 2.5%.

- B. Isochronous / Black Start: The Facility will be capable of operating in a zero droop (isochronous) mode of operation. When in this mode of operation, the frequency droop characteristic will be configured as needed to keep system frequency at a target. In a black start configuration, the target shall be 60 Hz. If isochronous is specified while in operation, the target shall be initialized to the grid frequency and the target increased or decreased from the Company System through the control interface.

(h) Control System Acceptance Test Procedures.

- (i) Conditions Precedent. The following conditions precedent must be satisfied prior to conducting the Control System Acceptance Test:

- Successful completion of the Acceptance Test.
- Facility has been successfully energized.
- All of the Facility's generators (as applicable) have been fully commissioned.
- The control system computer has been programmed for normal operations.
- All equipment that is relied upon for normal operations (including ancillary devices such as capacitors/inductors, energy storage device, statcom, etc.) shall have been commissioned and be operating within normal parameters.

- (ii) Facility Energy Equipment. In the event that all or any portion of the Facility's energy equipment is not available for the duration of

⁶ Percentage based on final (expected) settling value.

the Control System Acceptance Test, the Control System Acceptance Test will have to be re-run from the beginning unless Seller demonstrates to the satisfaction of the Company that the test results attained are consistent with the results that would have been attained if all of the equipment had been available for the duration of the test.

- (iii) Procedures. The Control System Acceptance Test will be conducted on Business Days during normal working hours on a mutually agreed upon schedule. No Control System Acceptance Test will be scheduled during the final 21 Days of a calendar year. No later than thirty (30) Days prior to conducting the Control System Acceptance Test, Company and Seller shall agree on a written protocol setting out the detailed procedure and criteria for passing the Control System Acceptance Test. Attachment O (Control System Acceptance Test Criteria) provides general criteria to be included in the written protocol for the Control System Acceptance Test. Within fifteen (15) Business Days of completion of the Control System Acceptance Test, Company shall notify Seller in writing whether the Control System Acceptance Test(s) has been passed and, if so, the date upon which such Control System Acceptance Test(s) was passed. If any changes have been made to the technical specifications of the Facility or the design of the Facility in accordance with Section 5(f) of Attachment A (Description of Generation, Conversion and Storage Facility), such changes shall be reflected in an amendment to this Agreement, and the written protocol for the Control Systems Acceptance Test shall be based on the Facility as modified. Such amendment shall be executed prior to conducting the Control System Acceptance Test and Company shall have no obligation for any delay in performing the Control Systems Acceptance Test due to the need to complete and execute such amendment.

- (i) Facility Security and Maintenance. Seller is responsible for securing the Facility. Seller shall have personnel available to respond to all calls related

to security incidents and shall take commercially reasonable efforts to prevent any security incidents. Seller is also responsible for maintaining the Facility, including vegetation management, to prevent security breaches. Seller shall comply with all commercially reasonable requests of Company to update security and/or maintenance if required to prevent security breaches.

- (j) Demonstration of Facility. Company shall have the right at any time, other than during maintenance or other special conditions, communicated by Seller, to notify Seller in writing of Seller's failure, as observed by Company and set forth in such written notice, to meet the operational and performance requirements specified in Section 2.11 (Fast Frequency Response Performance Metric) of this Agreement, and Section 1(b)(iii)(I), Section 1(g) (Active Power Control Interface) and Section 3 (Performance Standards) of this Attachment B (Facility Owned by Seller), and to require documentation or testing to verify compliance with such requirements. Upon receipt of such notice, Seller shall promptly investigate the matter, implement corrective action and provide to Company, within thirty (30) Days of such notice, a written report of both the results of such investigation and the corrective action taken by Seller; provided, that, if thirty (30) Days is not a reasonable time period to investigate the matter, implement corrective action and provide such written report, Seller shall complete the foregoing within such longer commercially reasonable period of time agreed to by the Parties in writing. If the Seller's report does not resolve the issue to Company's reasonable satisfaction, the Parties shall promptly commission a study to be performed by one of the engineering firms then included on the Qualified Independent Third-Party Consultants List attached to the Agreement as Attachment D (Consultants List) to evaluate the cause of the non-compliance and to make recommendations to remedy such non-compliance. Seller shall pay for the cost of the study. The study shall be completed within ninety (90) Days, unless the selected consultant determines such study cannot reasonably be completed within ninety (90) Days, in which case, such longer period of time as the selected consultant determines is necessary to complete such study shall apply. The consultant shall send the study to Company and Seller. Seller (and/or its Third-Party consultants and contractors), at Seller's expense,

shall take such action as the study shall recommend with the objective of resolving the non-compliance. Such recommendations shall be implemented by Seller to Company's reasonable satisfaction no later than forty-five (45) Days from the Day the completed study is issued by the consultant, unless such recommendations cannot reasonably be implemented within forty-five (45) Days, in which case, Seller shall implement such recommendations within such longer commercially reasonable period of time agreed to by the Parties in writing. Failure to implement such recommendations within this period shall constitute a material breach of this Agreement. Unless the aforementioned written report and study are being completed, and any recommendations are being implemented, solely to address Seller's failure to satisfy the requirements of Section 3(w) (Round Trip Efficiency) of this Attachment B (Facility Owned by Seller), the Company shall have the right to declare the Facility derated and in Seller-Attributable Non-Generation status until the Seller's aforementioned written report has been completed, any subsequent study commissioned by the Parties has been completed and any recommendations to resolve the non-compliance have been implemented to Company's reasonable satisfaction.

2. Operating Procedures. **[NOTE: NUMERICAL SPECIFICATIONS IN THIS SECTION 2 MAY VARY DEPENDING ON THE SPECIFIC PROJECT AND THE RESULTS OF THE PROJECT-SPECIFIC INTERCONNECTION REQUIREMENT STUDY.]**

- (a) Reviews of the Facility. Company may require periodic reviews of the Facility, maintenance records, available operating procedures and policies, and relay settings, and Seller shall implement changes Company deems necessary for parallel operation or to protect the Company System from damages resulting from the parallel operation of the Facility with the Company System.
- (b) Separation. Seller must separate from Company System whenever requested to do so by the Company System Operator pursuant to Article 8 (Company Dispatch) and Article 9 (Personnel and System Safety) of the Agreement.

- (c) Seller Logs. Logs shall be kept by Seller for information on unit availability including reasons for planned and forced outages, circuit breaker trip operations, relay operations, including target initiation, and other unusual events. Company shall have the right to review these logs, especially in analyzing system disturbances. Seller shall maintain such records for a period of not less than six (6) years.
- (d) Reclosing and Return to Service. Under no circumstances shall Seller, when separated from the Company System for any reason, including tripping during disturbances or due to equipment failure, reclose into the Company System without first obtaining specific approval to do so from the Company System Operator. Ramp rates, behavior and mode of operation upon return to service shall conform to verbal instructions from the System Operator or Active Power control from Company. Following "system black" conditions, the Facility shall not attempt to automatically reconnect to the grid (unless directed by the Company System Operator) so as to not interfere with blackstart procedures.
- (e) Reserved.
- (f) Reserved.
- (g) Critical Infrastructure Protection. Seller shall comply with the critical infrastructure protection requirements set forth in Section 1(b)(iii)(G) of this Attachment B (Facility Owned by Seller).
- (h) Allowed Operations. Facility shall be allowed to export energy to the Company System only when the [_____] circuit is in normal operating configuration served by breaker [_____] at [_____] Substation. **[TO BE DETERMINED BY COMPANY BASED ON THE RESULTS AND REQUIREMENTS OF THE IRS]**

3. Performance Standards.

- (a) Reactive Power Control. Seller shall control its reactive power by automatic voltage regulation control. Seller shall automatically regulate voltage at a point, the point of regulation, between the Seller's generator

terminal and the Point of Interconnection to be specified by Company, to within 0.5% of a voltage or power factor specified by the Company System Operator to the extent allowed by the Facility reactive power capabilities as defined in Section 3(b) (Reactive Power Characteristics) of this Attachment B (Facility Owned by Seller).

(b) Reactive Power Characteristics. **[THESE REQUIREMENTS MAY BE CHANGED BY COMPANY UPON COMPLETION OF THE IRS.]**

- (i) The Facility must deliver power up to the Allowed Capacity (MW) at a power factor between 95% lagging and 95% leading to the Company System as illustrated in the **[generator capability]** curve(s) attached to this Agreement as Exhibit B-2, which represents the Facility Composite (Generator and Energy Storage Capability Curve(s)). Facilities with a BESS with grid charging can operate with negative active power. These facilities shall provide automatic voltage control within their reactive capability while acting as a load (charging, negative active power generation). The automatic voltage control aspects of a BESS shall be seamless across the transition from acting as a generating resource to acting as a load. The Facility must be capable of automatically adjusting reactive control to maintain the bus voltage at the Point of Interconnection to meet the scheduled voltage set point target specified by the Company System Operator and be capable of supplying reactive power at the leading/lagging 0.95 power factor at all active power outputs down to zero active power. The voltage target will be specified remotely by the Company System Operator through the SCADA/EMS. The Facility's voltage set point target must reflect the Company voltage set point target controlled from the SCADA/EMS, without delay. The Facility should not normally operate on a fixed var or fixed power factor unless agreed by Company. The voltage setpoint target and present Facility minimum and maximum reactive power limits based on the Facility Composite capability curve shall be provided to the Company EMS through Company's Telemetry and Control.

- (ii) The Facility shall contain equipment able to continuously and actively control the output of reactive power under automatic voltage regulation control reacting to system voltage changes. The response requirements are differentiated for large and small signal disturbance performance characteristics. Small signal disturbances are those that reflect normal variations under non-disturbance conditions, the continuous operation range for voltage ride through: $0.80 \text{ pu} \leq V \leq 1.00 \text{ pu}$ at the point of interconnection. Large disturbance is where the voltage at the point of interconnection falls outside the continuous operating range.
- (iii) For small signal disturbances, reaction time between the step change in voltage and the reactive power change shall be less than 500 msec (no intentional time delay). The automatic voltage regulation response speed at the point of regulation shall be such that at least 90% of the initial voltage correction needed to reach the voltage control target will be achieved within 1 second following a step change. The percentage of rated reactive power output that the resource can exceed while reaching the settling band shall be less than five percent (5%).
- (iv) Large disturbances: Large disturbances are characterized by voltage falling outside of the continuous operating range. The Facility shall adhere to the following characteristics for large disturbances:

The response of each generating resource over its full operating range and for all expected grid conditions should be stable. The dynamic performance of each resource should be tuned to provide this stable response. Company will work with Seller to ensure during the interconnection process that each resource supports Company System reliability and provides a stable transient response to grid events. **[Note - The performance specifications described here may need to be modified based on studies performed for specific interconnections to provide a stable response.]**

Inverter-based resources shall operate in closed loop automatic voltage control at all times to support voltage regulation and voltage stability. Either the individual inverters or the plant-level closed loop automatic voltage controller must operate with a relatively fast response characteristic to mitigate steady-state voltage issues from causing dynamic voltage collapse. The plant-level controller may send voltage or reactive power set point changes to the individual inverters relatively fast, or the inverters will respond locally (depending on control architecture).

For a large disturbance step in voltage, measured at the inverter terminals, where voltage falls outside the continuous operating range, the positive sequence component of the inverter reactive current response must meet the performance specifications set forth below. These parameters may be adjusted following additional study and/or operational testing and performance.

Reaction time: Time between the step change in voltage and when the resource reactive power output begins responding to the change. The reaction time shall be less than 16 msec.

Rise time: Time between a step change in control signal input and when the reactive power output changes by 90 percent of its final value. The rise time shall be less than 100 msec.

Overshoot: Percentage of rated reactive current output that the resource can exceed when reaching the settling band. Overshoot will be determined following the IRS such that any overshoot in reactive power response does not cause Company System voltages to exceed acceptable voltage limits. The magnitude of the dynamic response may be requested to be reduced based on stability studies or actual operational data review.

If the Facility does not operate in accordance with Section 3(b) of this Attachment B (Facility Owned by Seller), Company may disconnect all or a part of Facility from Company System until Seller corrects its operation (such as by installing supplemental

reactive power equipment or additional control modifications, at Seller's expense).

(c) Ramp Rates.

Seller shall ensure that the ramp rate of the Facility is less 2 MW a minute for all conditions other than those under control of the Company System Operator and/or those due to desired frequency response, including start up, depletion of storage charge and resource, locally controlled startup and shut down.

(d) Ride Through.

Ride-Through requires that the resource continues to inject current within the "No Trip" zone of the voltage and frequency ride-through requirements. Unless approved during the Interconnection Requirements Study analysis, resources should not use "momentary cessation" within the ride-through regions for any of the ride-through requirements in this Attachment B (Facility Owned by Seller).

(e) Undervoltage Ride-Through.

The Facility, as a whole, will meet the following undervoltage ride-through requirements during low voltage affecting one or more of the three voltage phases ("V" is the voltage of any three voltage phases at the Point of Interconnection). For alarm conditions the Facility shall not disconnect from the Company System unless the Facility's equipment is at risk of damage. This is necessary in order to coordinate with the existing Company System. **[THESE VALUES MAY BE CHANGED BY COMPANY UPON COMPLETION OF THE IRS. WITHOUT LIMITATION, FOR A DISTRIBUTION-CONNECTED FACILITY, UPON COMPLETION OF THE IRS THE COMPANY MAY SPECIFY REQUIREMENTS FOR A MANDATORY DISCONNECTION FROM THE COMPANY SYSTEM.]**:

0.80 pu \leq V \leq 1.00 pu The Facility remains connected to the Company System and in continuous operation.

0.00 pu \leq V < 0.80 pu The Facility remains connected to the Company System and in

continuous operation for a minimum of 600 milliseconds per event (while "V" remains in this range). The Facility may initiate an alarm if "V" remains in this range for more than 600 milliseconds; the duration of the event is measured from the point at which the voltage drops below 0.80 pu and ends when the voltage is at or above 0.80 pu. The 600 milliseconds represents a delayed clearing time of 30 cycles plus breaker opening time.

Protective Undervoltage Relaying (27) shall be set to alarm only to meet the above ride-through requirements, and shall not initiate a disconnect from the Company System unless Seller reasonably determines based upon Good Engineering and Operating Practices that the Facility's equipment is at risk of damage. This is necessary in order to coordinate with the existing Company System.

Seller shall have sufficient capacity to fulfill the above mentioned requirements to ride-through subsequent events 300 cycles or more apart, between which the voltage at the POI recovers above 0.80 pu. **[THE ACTUAL RIDE-THROUGH TIMES WILL BE DETERMINED BY COMPANY IN CONNECTION WITH THE IRS]**

(f) Over Voltage Ride-Through.

The overvoltage protection equipment at the Facility shall be set so that the Facility will meet the following overvoltage ride-through requirements during high voltage affecting one or more of the three voltage phases (as described below) ("V" is the voltage of any of the three voltage phases at the Point of Interconnection). For alarm conditions the Facility should not disconnect from the Company System unless the Facility's equipment is at risk of damage. This is necessary in order to coordinate with the existing Company System. **[THESE VALUES MAY BE CHANGED BY THE COMPANY UPON COMPLETION OF THE IRS. WITHOUT LIMITATION,**

FOR A DISTRIBUTION-CONNECTED FACILITY, UPON COMPLETION OF THE IRS THE COMPANY MAY SPECIFY REQUIREMENTS FOR A MANDATORY DISCONNECTION FROM THE COMPANY SYSTEM AT $V > 1.2$ pu. RIDE-THROUGH REQUIREMENTS FOR OTHER SYSTEMS WILL BE DETERMINED IN THE IRS.] :

$1.00 \text{ pu} < V \leq 1.10 \text{ pu}$ The Facility remains connected to the Company System.

$1.10 \text{ pu} < V \leq 1.15 \text{ pu}$ The Facility remains connected to the Company System and in continuous operation no less than 30 seconds; the duration of the event is measured from the point at which the voltage increases at or above 1.1 pu and ends when voltage is at or below 1.1 pu.

$V > 1.15 \text{ pu}$ The Facility remains connected to the Company System and in continuous operation for as long as possible as allowed by the equipment operational limitations.

Protective Overvoltage Relaying (59) shall be set to alarm only to meet the above ride-through requirements, and shall not initiate a disconnect from the Company System unless Seller reasonably determines based upon Good Engineering and Operating Practices that the Facility's equipment is at risk of damage. This is necessary in order to coordinate with the existing Company System.

(g) Transient Stability Ride-Through.

The Facility shall be designed such that the transient stability of Company System is maintained for normally cleared and secondarily cleared faults. The Facility will be required to remain connected through anticipated rates of change of frequency **[TO BE PROVIDED UPON COMPLETION OF IRS]**

(h) [RESERVED]

(i) Underfrequency Ride-Through.

The Facility shall meet the following underfrequency ride-through requirements during an underfrequency disturbance, and export of power shall continue with output adjusted as appropriate for Facility droop response consistent with Section 1(g)(xi) (Active Power - Frequency Response (DROOP)), Section 1(g)(xii) (Dynamic Active Power - Frequency Performance), and **[FOR FACILITIES WITH STORAGE]** Section 1(g)(xiii) (Alternate Active Power / Frequency Response Modes) of this Attachment B (Facility Owned by Seller) ("f" is the Company System frequency at the Point of Interconnection):

57.0 Hz \leq f \leq 60.0 Hz The Facility remains connected to the Company System and in continuous operation.

56.0 Hz \leq f < 57.0 Hz The Facility remains connected to the Company System and in continuous operation for at least six (6) seconds per event. The duration of the event is from the point at which the frequency is below 57 Hz and ends when the frequency is at or above 57 Hz. The Facility may initiate an alarm if frequency remains in this range for more than six (6) seconds.

f < 56.0 Hz The Facility remains connected to the Company System and in continuous operation for the duration allowed by the equipment operational limitations. The Facility may initiate an alarm immediately.

Protective Underfrequency Relaying (81U) shall be set to alarm only to meet the above ride-through requirements, and shall not initiate a disconnect from the Company System unless Seller reasonably determines based upon Good Engineering and Operating Practices that the

Facility's equipment is at risk of damage. This is necessary in order to coordinate with the existing Company System.

Any tripping on calculated frequency should be based on accurately calculated and filtered frequency measurement over a time frame of minimum six cycles, or other period as specified by the Company, and should not use an instantaneously calculated value.

(j) Overfrequency Ride-Through.

The Facility will behave as specified below for overfrequency conditions, and export of power shall continue with output adjusted as appropriate for Facility droop response consistent with Section 1(g)(xi) (Active Power - Frequency Response (DROOP)), Section 1(g)(xii) (Dynamic Active Power - Frequency Performance), and **[FOR FACILITIES WITH STORAGE]** Section 1(g)(xiii) (Alternate Active Power / Frequency Response Modes) ("f" is the Company System frequency at the Point of Interconnection):

60.0 Hz < f ≤ 61.5 Hz The Facility remains connected to the Company System and in continuous operation.

61.5 Hz < f ≤ 63.0 Hz The Facility remains connected to the Company System for at least ten (10) seconds. After ten seconds, the Facility may initiate an alarm and the Facility remains connected and producing power for the duration allowed by the equipment operational limitations. The duration of condition is from the point at which the frequency is above 61.5 Hz and ends when the frequency is at or below 63.0 Hz.

f > 63.0 Hz The Facility remains connected to the Company System for the duration allowed by the

equipment operational
limitations. The Facility may
initiate an alarm immediately.

Protective Overfrequency Relaying (810) shall be set to alarm only to meet the above ride-through requirements, and shall not initiate a disconnect from the Company System unless Seller reasonably determines based upon Good Engineering and Operating Practices that the Facility's equipment is at risk of damage. This is necessary in order to coordinate with the existing Company System.

Any tripping on calculated frequency should be based on accurately calculated and filtered frequency measurement over a time frame of minimum six cycles, or other period as specified by the Company, and should not use an instantaneously calculated value.

(k) Successive Faults.

If the resource necessitates tripping to protect from the cumulative effects of those successive faults, in a period of time to ensure safety and equipment integrity, the constraint and time periods should be provided for inclusion in the interconnection study. For all cases, at a minimum, the ride-through requirements shall be met for two ride-through events within two seconds to allow for the Company's transmission automatic reclosing attempt. **[Note - this requirement may be modified based on the results of the IRS.]**

(l) Rate of Change of Frequency ("ROCOF").

The inverter-based resources in the Facility shall not use rate-of-change-of-frequency protection unless an equipment limitation exists that requires the inverter to trip on high ROCOF. Any ROCOF tripping must be approved by Company.

(m) Phase Angle Shift Ride-Through.

The Facility equipment shall ride through phase angle shift of up to ([]) **[Note - requirements will depend on Facility]**. Inverter phase lock loop (PLL) loss of synchronism shall not cause the inverter to trip or enter momentary cessation within the voltage and

frequency ride-through region. Inverters must be capable of riding through temporary loss of synchronism, and regain synchronism, without causing a trip or momentary cessation of the resource.

(n) DC Protection.

If the Facility requires DC reverse current protection, such protection must be coordinated with the inverter equipment module ratings and set to operate for short circuits on the DC side. DC reverse current protection shall not operate for transient overvoltage or for AC-side faults.

(o) Voltage Flicker.

Any voltage flicker on the Company System caused by the Facility shall not exceed the limits stated in IEEE Standard 1453-2011, or latest version "Recommended Practice - Adoption of IEC 61000-4-15:2010, Electromagnetic compatibility (EMC) - Testing and measurement techniques - Flickermeter - Functional and design specifications".

(p) Harmonics.

Harmonic distortion at the Point of Interconnection caused by the Facility shall not exceed the limits stated in IEEE Standard 519-1992, or latest version "Recommended Practices and Requirements for Harmonic Control in Electrical Power Systems". Seller shall be responsible for the installation of any necessary controls or hardware to limit the voltage and current harmonics generated from the Facility to defined levels.

(q) Grid Forming Capabilities.

[NOTE APPLICABILITY BASED ON RESOURCE TYPE AND DESIGN, FOR INVERTER BASED RESOURCES] Seller Facility inverters shall be capable of operating in grid forming mode supporting system operation under normal and emergency conditions without relying on the characteristics of synchronous machines. This includes operation as a current independent ac voltage source during normal and transient conditions (as long as no limits are reached within the inverter) and the ability to synchronize to other voltage sources or operate autonomously if a grid reference is unavailable.

- (i) Seller shall operate the Facility in grid forming mode only as directed by the Company System Operator, in its sole discretion. Such mode of operation shall be indicated to the Company System Operator through telemetry.
- (ii) The Facility shall include safeguards to prevent the unintentional switching of the Facility into and out of grid forming mode. The safeguards shall be approved in writing by the Company and implemented by the Seller prior to control system testing.

(r) Black Start Capability.

[NOTE - APPLICABILITY BASED ON RESOURCE TYPE AND DESIGN, FOR INVERTER BASED RESOURCES] [For synchronous machines, require capability to operate in isochronous control and black start.] The BESS shall be capable of grid forming inverter capability so it can generate its own AC waveform rather than relying on a grid voltage to synchronize and maintain frequency. Further, inverter-based resources shall ensure they have sufficient energy storage to maintain power injection to the grid during system restoration (i.e., have power available when and if called upon). Inverter based facilities should be capable of support as a black start cranking path to start synchronous generators for restoration.

(s) Provision of Synthetic Inertia. **[TO BE DETERMINED BASED ON IRS.]**

(t) Generator Step-Up Transformer Impedance.

The generator step-up transformer impedance shall be between [] percent and [] percent, inclusive, on transformer OA rating. **[NOTE: THESE VALUES WILL BE BASED ON THE RESULTS OF THE IRS.]**

(u) Control Systems and Auxiliary Equipment.

The power source for control systems and auxiliary equipment required for normal operation of the Facility shall be designed to be immune from system transients in accordance with the Public Utilities Commission of the State of Hawai'i tariff for Hawai'i Electric Light Company, Inc. Rule No. 2, Character of Service (Revised Sheet No. 5, effective Oct. 20, 1991) and Section

3.2(A) (6) (Facility Protection and Control Equipment) to meet the performance during under/over voltage and under/over frequency conditions pursuant to Section 3(e) (Undervoltage Ride-Through), Section 3(f) (Over Voltage Ride-Through), Section 3(i) (Underfrequency Ride-Through) and Section 3(j) (Overfrequency Ride-Through) of this Attachment B (Facility Owned by Seller).

(v) Frequency Response.

Seller shall comply with the requirements of Section 1(g)(xi) (Frequency Response (DROOP)), Section 1(g)(xii) (Dynamic Active Power - Frequency Performance), and **[FOR FACILITIES WITH STORAGE]** Section 1(g)(xiii) (Alternate Active Power / Frequency Response Modes) of this Attachment B (Facility Owned by Seller).

(w) Round Trip Efficiency.

The round trip efficiency of the BESS as measured at the POI shall be not less than [] percent ([]%).

[Drafting Note: The percentage for round trip efficiency should be taken from Seller's response to the RFP.]

4. Maintenance of Seller-Owned Interconnection Facilities.

- (a) Seller must address any Disconnection Event (as defined below) according to the requirements of this Section 4 (Maintenance of Seller-Owned Interconnection Facilities) of Attachment B (Facility Owned by Seller). For the purposes of this Section 4 (Maintenance of Seller-Owned Interconnection Facilities), a "Disconnection Event" is the removal of [7.5 MW] [or 100% of capacity for facilities with capacity less than 7.5 MW] or more from Company System and/or disconnection of the Facility from the Company's System (i) that is not the result of Company dispatch, frequency droop response, or isolation of the Facility resulting from designed protection fault clearing, and (ii) for which Company does not issue the written notice for failure to meet operational and performance requirements as set forth in Section 1(j) (Demonstration of Facility) of this Attachment B (Facility Owned by Seller). Company's election to exercise its rights under Section 1(j) (Demonstration of Facility) shall not relieve Seller of its obligation to comply with the requirements of this Section 4

(Maintenance of Seller-Owned Interconnection Facilities) for any future Disconnection Event during the pendency of such election or thereafter.

- (b) For every Disconnection Event from the Company System, Seller shall investigate the cause. Within three (3) Business Days, Seller shall provide, in writing to Company, an incident report that summarizes the sequence of events and probable cause.
- (c) Within forty-five (45) Days of a Disconnection Event, Seller shall provide, in writing to Company, Seller's findings, data relied upon for such findings, and proposed actions to prevent reoccurrence of a Disconnection Event ("Proposed Actions"). Company may assist Seller in determining the causes of and recommendations to remedy or prevent a Disconnection Event ("Company's Recommendations"). Seller shall implement such Proposed Actions (as modified to incorporate the Company's Recommendations, if any) and Company's Recommendations (if any) in accordance with the time period agreed to by the Parties.
- (d) In the event Seller and Company disagree as to (i) whether a Disconnection Event occurred, (ii) the sequence of events and/or probable cause of the Disconnection Event, (iii) the Proposed Actions, (iv) Company's Recommendations, and/or (v) the time period to implement the Proposed Actions and/or Company's Recommendations, then the Parties shall follow the procedure set forth in Section 5 (Expedited Dispute Resolution) of this Attachment B (Facility Owned by Seller).
- (e) Upon the fourth (4th) Disconnection Event (and each subsequent Disconnection Event) within any Contract Year, the Parties shall follow the procedures set forth in Section 4(a) and Section 4(d) of Attachment B (Facility Owned by Seller), to the extent applicable. If after following the procedures set forth in this Section 4 (Maintenance of Seller-Owned Interconnection Facilities) of Attachment B (Facility Owned by Seller), Seller and Company continue to have a disagreement as to (1) the probable cause of the Disconnection Event, (2) the Proposed Actions, (3) the Company's Recommendations, and/or (4) the time period to implement the Proposed Actions and/or the Company's Recommendations, then the

Parties shall commission a study to be performed by a qualified independent Third-Party consultant ("Qualified Consultant") chosen from the Qualified Independent Third-Party Consultants List ("Consultants List") attached to the Agreement as Attachment D (Consultants List). Such study shall review the design of, review the operating and maintenance procedures dealing with, recommend modifications to, and determine the type of maintenance that should be performed on Seller-Owned Interconnection Facilities ("Study"). Seller and Company shall each pay for one-half of the total cost of the Study. The Study shall be completed within ninety (90) Days from such fourth Disconnection Event (and each subsequent Disconnection Event) within any Contract Year, unless the Qualified Consultant determines the Study cannot reasonably be completed within ninety (90) Days, in which case, such longer period of time as the Qualified Consultant determines is necessary to complete the Study shall apply. The Qualified Consultant shall send the Study to Company and Seller. Seller (and/or its Third-Party consultants and contractors), at Seller's expense, shall change the design of, change the operating and maintenance procedures dealing with, implement modifications to, and/or perform the maintenance on Seller-Owned Interconnection Facilities recommended by the Study. Such design changes, operating and maintenance procedure changes, modifications, and/or maintenance shall be completed no later than forty-five (45) Days from the Day the completed Study is issued by the Qualified Consultant, unless such design changes, operating and maintenance procedure changes, modifications, and/or maintenance cannot reasonably be completed within forty-five (45) Days, in which case, Seller shall complete the foregoing within such longer commercially reasonable period of time agreed to by the Parties in writing. Company shall have the right to derate the Facility to a level that maintains reliable operations in accordance with Good Engineering and Operating Practices, and the Facility shall be deemed to be in Seller-Attributable Non-Generation status, until the study has been completed and the study's recommendations have been implemented by Seller to Company's reasonable satisfaction. Nothing in this provision shall affect Company's right to dispatch the Facility as provided for in this Agreement.

(f) The Consultants List attached hereto as Attachment D (Consultants List) contains the names of engineering firms which both Parties agree are fully qualified to perform the Study. At any time, except when a Study is being conducted, either Party may remove a particular consultant from the Consultants List by giving written notice of such removal to the other Party. However, neither Party may remove a name or names from the Consultants List without approval of the other Party if such removal would leave the list without any names. Intended deletions shall be effective upon receipt of notice by the other Party, provided that such deletions do not leave the Consultants List without any names. Proposed additions to the Consultants List shall automatically become effective thirty (30) Days after notice is received by the other Party unless written objection is made by such other Party within said thirty (30) Day period. By mutual agreement between the Parties, a new name or names may be added to the Consultants List at any time.

5. Expedited Dispute Resolution.

If there is a disagreement between Company and Seller regarding (i) whether a Disconnection Event occurred, (ii) the sequence of events and/or probable cause of the Disconnection Event, (iii) the Proposed Actions, (iv) the Company's Recommendations, and (v) the time period to implement the Proposed Actions and/or the Company's Recommendations, then authorized representatives from Company and Seller, having full authority to settle the disagreement, shall meet in Hawai'i (or by telephone conference) and attempt in good faith to settle the disagreement. Unless otherwise agreed in writing by the Parties, the Parties shall devote no more than five (5) Business Days to settle the disagreement in good faith. In the event the Parties are unable to settle the disagreement after the expiration of the time period, then such disagreement shall constitute a Dispute for which either Party may pursue the dispute resolution procedure set forth in Section 28.2 (Dispute Resolution Procedures, Mediation) of this Agreement.

6. Modeling.

(a) Seller's Obligation to Provide Models. Within 30 Days of Company's written request, but no later than the Commercial Operations Date, Seller shall provide

detailed data regarding the design and location of the Facility, in a form reasonably satisfactory to Company, to allow the modeling of the inverters and any other equipment within the Facility identified in the IRS which utilizes Source Code (such as energy storage system, STATCOM or DVAR equipment), including, but not limited to, integrated and validated power flow and transient stability models (such as PSS/E models), a short circuit model (such as an ASPEN model), and an electro-magnetic transient model (such as a PSCAD model) of the inverters and any additional equipment identified in the IRS as set forth above, applied assumptions, and pertinent data sets (each a "Required Model" and collectively, the "Required Models"). Thereafter, during the Term, Seller shall provide working updates of any Required Model within 30 Days of (i) Company's written request, or (ii) Seller obtaining knowledge or notice that any Required Model has been modified, updated or superseded by the Source Code Owner.

- (b) Escrow Establishment. If, pursuant to Section 6(a) (Seller's Obligation to Provide Models) of this Attachment B (Facility Owned by Seller), the Required Models are provided to the Company in a form other than Source Code, Seller shall arrange for and ensure that the Source Code for the relevant Required Model is deposited into the Source Code Escrow as set forth below in Section 6(b)(i) (Source Code Escrow) of this Attachment B (Facility Owned by Seller) no later than the time periods set forth in Section 6(a) (Seller's Obligation to Provide Models) of this Attachment B (Facility Owned by Seller) for delivery of the Required Models. Seller shall be responsible for all costs associated with establishing and maintaining the Source Code Escrow. If, however, Seller is unable to deposit the required Source Code into the Source Code Escrow within the time periods set forth in Section 6(a) (Seller's Obligation to Provide Models), Seller shall, no later than such time periods, instead establish a monetary escrow as set forth below in Section 6(b)(ii) (Monetary Escrow) of this Attachment B (Facility Owned by Seller).

- (i) Source Code Escrow.

(A) Establishment of Source Code Escrow. If the Required Models are not provided to the Company in the

form of Source Code pursuant to Section 6(a) of this Attachment B (Facility Owned by Seller), Seller shall: (a) arrange for and ensure the deposit of a copy of the current version of the Source Code and relevant documentation for all Required Models with the Source Code Escrow Agent under the terms and conditions of the Source Code Escrow Agreement, and (b) arrange for and ensure the update of the deposited Source Code and relevant documentation for Major Releases and Minor Releases of the Required Models as soon as reasonably possible after they are made generally available.

(B) Release Conditions. Company shall have the right to obtain from the Source Code Escrow Agent one copy of the escrowed Source Code for the Required Models, under the following conditions upon Company's request:

(i) A receiver, trustee, or similar officer is appointed, pursuant to federal, state or applicable foreign law, for the Source Code Owner;

(ii) Any voluntary or involuntary petition or proceeding is instituted, under (x) U.S. bankruptcy laws or (y) any other bankruptcy, insolvency or similar proceeding outside of the United States, by or against the Source Code Owner; or

(iii) Failure of the Source Code Owner to function as a going concern or operate in the ordinary course; or

(iv) Seller and the Source Code Owner fail to provide to Company the Required Models or updated Required Models, or, alternatively, fail to issue a Source Code LC, within the time periods set forth in Section 6(a) (Seller's Obligation to Provide Models) of this Attachment B (Facility Owned by Seller), Company gives written notice of such failure to Seller and the Source Code Owner, and Seller and Source Code Owner fail to remedy such breach within five (5) Days following receipt of such notice.

(C) Remedies. If Company has the right to obtain from the Source Code Escrow Agent one copy of the escrowed Source Code for the Required Models pursuant to Section 6(b) (i) (B) (Release Conditions) of Attachment B (Facility Owned by Seller), and Company finds that Seller failed to arrange for and ensure the update the Source Code Escrow with the modified and/or updated Source Code and

relevant documentation for Major Releases and Minor Releases of the Required Models as provided in Section 6(b)(i) (Establishment of Source Code Escrow) of Attachment B (Facility Owned by Seller) or that the Source Code for the Required Models is incomplete or otherwise unusable, Seller shall be liable to Company for liquidated damages in the amount of \$500 per Day for each Day Seller fails to provide such Source Code to Company or such update to the Source Code to Company from the date such Major Release or Minor Release was first made available by the Source Code Owner to customers of the Source Code Owner. Failure to provide the updated Source Code of the Required Models within 30 Days' notice from Company of a breach of Section 6(b)(i)(A) (Establishment of Source Code Escrow) of Attachment B (Facility Owned by Seller); provided, that Seller has also failed to provide a satisfactory Source Code LC as set forth in Section 6(b)(ii) (Source Code Security) of this Attachment B (Facility Owned by Seller) shall constitute an Event of Default pursuant to Section 15.2(f) under the Agreement.

(D) Certification. The Source Code Escrow Agent shall release the Source Code of the Required Models to Company upon receipt of a signed statement by a representative of Company that reads substantially as follows:

The undersigned hereby certifies that (i) I am duly authorized to execute this document on behalf of Hawai'i Electric Company, Inc. ("Hawai'i Electric Light"), and (ii) Hawai'i Electric Light is entitled to a copy of the Source Code of the Required Models Pursuant to Section 6(b)(i)(B) (Release Conditions) of Attachment B (Facility Owned by Seller) of the Power Purchase Agreement dated as of _____, between _____, and Hawai'i Electric Light.

(E) Authorized Use. If Company becomes entitled to a release of the Source Code of the Required Models from escrow, Company may thereafter correct, modify, update and enhance the Required Models for the sole purpose of providing itself the support and maintenance it otherwise would have been entitled to if it had been provided the Required Models by Seller under Section 6(a) (Seller's

Obligation to Provide Models) of this Attachment B (Facility Owned By Seller) (the "Source Code Authorized Use").

(F) Confidentiality Obligations. Company shall keep the Source Code of the Required Models confidential pursuant to the confidentiality obligations of the Source Code Escrow Agreement. Company shall restrict access to the Source Code of the Required Models to those employees, independent contractors and consultants of Company who have agreed in writing to be bound by confidentiality and use obligations consistent with those specified in the Escrow Agreement, and who have a need to access the Source Code of the Required Models on behalf of Company to carry out their duties for the Source Code Authorized Use. Promptly upon Seller's request, Company shall provide Seller with the names and contact information of all individuals who have accessed the Source Code of the Required Models, and shall take all reasonable actions required to recover any such Source Code in the event of loss or misappropriation, or to otherwise prevent their unauthorized disclosure or use.

(ii) Source Code Security.

(A) Establishment of Source Code Security.

If the Required Models and their relevant Source Code are not provided to the Company in the form of Source Code pursuant to Section 6(a) (Seller's Obligation to Provide Models) of this Attachment B (Facility Owned by Seller) and if the Seller is unable to arrange for and ensure the deposit of the Source Code into the Source Code Escrow established for the benefit of the Company pursuant to Section 6(b)(i) (Source Code Escrow) of this Attachment B (Facility Owned by Seller) then, no later than the time periods set forth in Section 6(a) (Seller's Obligation to Provide Models) of this Attachment B (Facility Owned by Seller) for delivery of the Required Models and Source Code, Seller shall provide an irrevocable standby letter of credit (the "Source Code LC") with no documentation requirement in the amount of Two Hundred Fifty Thousand Dollars (\$250,000) per Required Model (and its relevant Source Code) substantially in the form attached to this Agreement as Attachment M (Form of Letter of Credit) from a bank chartered in the United States with a credit rating of "A-" or better from Standard & Poor's or A3 or better from Moody's. Such letter of credit shall be issued for a minimum term of one (1) year. Furthermore, at the end of each year the security shall be renewed for an additional one (1) year term so that at the time of such

renewal, the remaining term of any such security shall not be less than one (1) year. The letter of credit shall include a provision for at least thirty (30) Days' advance notice to Company of any expiration or earlier termination of the letter of credit so as to allow Company sufficient time to exercise its rights under said security if Seller fails to extend or replace the security. In all cases, the reasonable costs and expenses of establishing, renewing, substituting, canceling, increasing, reducing, or otherwise administering the letter of credit shall be borne by Seller.

(B) Release Conditions. Company shall have the right to draw on the letter of credit the funds necessary to develop and recreate the Required Model or Required Models upon Company's request if Seller fails to provide the Company the Required Models or updated Required Models within the time periods set forth in Section 6(a) (Seller's Obligation to Provide Models) or Section 6(b)(i)(C) (Remedies) of this Attachment B (Facility Owned by Seller), Company gives written notice of such failure to Seller, and Seller fails to remedy such breach within five (5) Days following receipt of such notice for a breach under Section 6(a) (Seller's Obligation to Provide Models, or within thirty (30) Days following receipt of such notice for a breach under Section 6(b)(i)(C) (Remedies).

(C) Extend Letter of Credit. If the letter of credit is not renewed or extended no later than thirty (30) Days prior to its expiration or earlier termination, Company shall have the right to draw immediately upon the full amount of the letter of credit and to place the proceeds of such draw (the "Proceeds"), at Seller's cost, in an escrow account in accordance with Section 6(b)(ii)(D) (Proceeds Escrow), until and unless Seller provides a substitute form of letter of credit meeting the requirements of this Section 6(b)(ii) (Source Code Security) of this Attachment B (Facility Owned by Seller).

(D) Proceeds Escrow. If Company draws on the letter of credit pursuant to Section 6(b)(ii)(C) (Extend Letter of Credit) of this Attachment B (Facility Owned by Seller), Company shall, in order to avoid comingling the Proceeds, have the right but not the obligation to place the Proceeds in an escrow account as provided in this Section 6(b)(ii)(D) (Proceeds Escrow) of this Attachment B (Facility Owned by Seller) with a reputable escrow agent acceptable to Company ("Proceeds Escrow Agent") subject to an escrow

agreement acceptable to Company ("Proceeds Escrow Agreement"). Without limitation to the generality of the foregoing, a federally-insured bank shall be deemed to be a "reputable escrow agent." Company shall have the right to apply the Proceeds as necessary to recover amounts Company is owed pursuant to this Section 6 (Modeling) of this Attachment B (Facility Owned by Seller). To that end, the Proceeds Escrow Agreement governing such escrow account shall give Company the sole authority to draw from the account. Seller shall not be a party to such Proceeds Escrow Agreement and shall have no rights to the Proceeds. Upon full satisfaction of Seller's obligations under Section 6 (Modeling) of this Attachment B (Facility Owned by Seller), Company shall instruct the Proceeds Escrow Agent to remit to the bank that issued the letter of credit that was the source of the Proceeds the remaining balance (if any) of the Proceeds. If there is more than one escrow account with Proceeds, Company may, in its sole discretion, draw on such accounts in any sequence Company may select. Any failure to draw upon the Proceeds for any damages or other amounts due Company shall not prejudice Company's rights to recover such damages or amounts in any other manner.

(E) Seller's Obligation. If the letter of credit is not sufficient to cover Company's associated consultant fees, costs and expenses to develop and recreate the Required Models, Seller shall pay to Company the difference within ten (10) Days of Company's written notice to Seller.

(F) Model Verification. Seller shall work with the Company to validate the new Required Models developed by or on behalf of Company within sixty (60) Days of receiving such new Required Models. Seller shall also arrange for and ensure that Company may obtain new Required Models directly from the Source Code Owner in the event that Seller ceases to operate as a going concern or is subject to voluntary or involuntary bankruptcy and is unable or unwilling to obtain the new Required Models from the Source Code Owner.

(G) Certification. The terms of the letter of credit shall provide for a release of the funds, or in the event the funds have been placed into a Proceeds Escrow, the Proceeds Escrow Agent shall release the necessary funds to Company upon receipt of a signed statement by a

representative of Company that reads substantially as follows:

The undersigned hereby certifies that (i) I am duly authorized to execute this document on behalf of Hawai'i Electric Light Company, Inc. ("Hawai'i Electric Light"), and (ii) Hawai'i Electric Light is entitled to \$ _____, pursuant to Section 6(b)(ii)(B) (Release Conditions) of Attachment B (Facility Owned by Seller) of the Power Purchase Agreement dated as of _____, between _____, and Hawai'i Electric Light.

(H) Authorized Use. If Company becomes entitled to a draw of funds from the Source Code Security or a release of funds from the Proceeds Escrow, Company may thereafter use such funds to develop, recreate, correct, modify, update and enhance the Required Models for the sole purpose of providing itself the support and maintenance it otherwise would have been entitled to if it had been provided the Required Models by Seller under Section 6(a) (Seller's Obligation to Provide Models) of this Attachment B (Facility Owned by Seller).

(iii) Supplementary Agreement. The parties stipulate and agree that the escrow provisions in this Section 6(b) (Escrow Establishment) of Attachment B (Facility Owned by Seller) and the Source Code Escrow Agreement and Proceeds Escrow Agreement are "supplementary agreements" as contemplated in Section 365(n)(1)(B) of the Code. In any voluntary or involuntary bankruptcy proceeding involving Seller, failure by Company to assert its rights to "retain its rights" to the intellectual property encompassed by the Source Code or the funds in the Proceeds Escrow, pursuant to Section 365(n)(1)(B) of the Code, under an executory contract rejected in a bankruptcy proceeding, shall not be construed as an election to terminate the contract by Company under Section 365(n)(1)(A) of the Code.

7. Testing Requirements.

(a) Testing Requirements. Once the Control System Acceptance Test has been successfully passed, Seller shall not replace and/or change the configuration of the

Facility Control, inverter control settings and/or ancillary device controls, without prior written notice to Company. In the event of any such replacement and/or change, the relevant test(s) of the Control System Acceptance Test shall be redone and must be successfully passed before the replacement or altered equipment is allowed to be placed in normal operations. In the event that Company reasonably determines that such replacement and/or change of controls makes it inadvisable for the Facility to continue in normal operations without a further Control Systems Acceptance Test, the Facility shall be deemed to be in Seller-Attributable Non-Generation status until the new relevant tests of the Control System Acceptance Test have been successfully passed.

- (b) Periodic Testing. Seller shall coordinate periodic testing of the Facility with Company to ensure that the Facility is meeting the performance standards specified under this Agreement.

8. Data and Forecasting.

Seller shall provide Site, meteorological and production data in accordance with the terms of Article 6 (Forecasting) of this Agreement and the following requirements:

- (i) Physical Site Data: Seller shall provide Company with an accurate description of the physical Site, including but not limited to the following, **[as appropriate to Facility resource type(s) and use of storage]** which may not be changed during the Term without Company's prior written consent:

- A. Location Facility Map showing the layout of the Facility (coverage area or footprint) and the coordinates (latitude and longitude) of generating equipment:

Solar PV: elevation (above ground), orientation angle and direction (north-east-south-west plane) of arrays/concentrators.

Wind Generators: coordinates (latitude and longitude) and height above ground of each wind turbine hub.

- B. Location (latitude and longitude) and elevation (above ground) of each MMT/MMS and elevation (above ground) of each field measurement device for, e.g., air density, ambient air pressure and ambient air temperature, located at each MMT or each field measurement device located on such MMS.
- C. For solar resource inverters: Inverter type, power rating, array configuration to inverters and DC rating of the Facility at the following standard test conditions: irradiance of 1000 W/m², air mass 1.5, and cell temperature 25° C.
- D. Solar generation technology employed at the Facility with temperature dependence, mounting and module type.
- E. Wind generation technology employed at the Facility with representative power curve(s).
- F. BESS technology and related auxiliary equipment, location and type.

(ii) Meteorological and Production Data:

- A. Seller shall install and maintain a minimum of two MMS for facilities that have either (i) a DC rating of the Facility of 5 MW or greater or (ii) a coverage area greater than one square kilometer.
- B. Placement of each MMS should account for the microclimate of the area and Facility coverage area and shall be oriented with respect to the primary wind direction.
- C. Seller shall provide to Company, via SCADA communication and protocol acceptable to Company to support operations and forecasting needs at a continuous scan, all meteorological and production data required under this Agreement updated every 2 seconds.
- D. Seller shall arrange for a dedicated distribution voltage line to provide separate service from Company, or for such other

independent, backup power source as approved by Company in writing, to temporarily store and record the meteorological data from the field measuring devices at the MMSs. Any such backup power source must be capable of providing power for the field measurement devices for a reasonable period of time until primary power is restored. The same backup power source can serve multiple MMSs as needed by the Facility.

(iii) Units and Accuracy:

- A. [For PV] The Table below shows minimum required solar irradiance measurements for various types of solar generation technology. **[DRAFTING NOTE: VALUES NEED TO BE INSERTED INTO TABLE.]** This value may not be derived.

Solar Technology	Direct Normal Irradiance	Global Irradiance (GHI)	Plane of Array Irradiance (POA)
Flat Plate (fixed horizontal, fixed angle, tracking, roof mounted)		X	X

- B. Units and accuracy of measured parameters to be provided to Company in real time shall be as shown in the Table below. These represent the minimum required accuracies.

**Table of Units and Accuracy of
Meteorological and Production Data (PV)**

Parameter	Data Source	Unit	Range	Accuracy
Global Horizontal Irradiance at MMS	Pyranometer or equivalent	W/m ²	0 to 1500 W/m ²	Secondary standard per ISO 9060 or ≤ 3% from 100 W/m ² to 1500 W/m ² if using a PV Reference Cell
Plane of Array Irradiance on same axis as array	Pyranometer or equivalent	W/m ²	0 to 1500 W/m ²	Secondary standard per ISO 9060 or ≤ 3% from 100 W/m ² to 1500 W/m ² if using a PV Reference Cell
Back of Panel temperature at array height	Temperature probe	°C	-20 to +50 °C	+/-1 °C
Power production of Facility	Measured at POI	MW	Up to Capacity	+/-0.1 MW
Inverters Available*	Seller's system	digital	Up to the number of installed inverters	
	Ratio of inverters online/number of inverters	%	0 to 100%	
Power Possible*	Seller's Model	MW	0 to Allowed Capacity	+/-0.1 MW

**Table of Units and Accuracy of
Meteorological and Production Data (Wind)**

Parameter	Data Source	Unit	Range	Accuracy
Wind speed at MMT (hub height)	Cup or sonic anemometer	Mph	0 to 134 mph	+/-1 mph
Wind direction at MMT (hub height)	Vane, sonic device or equivalent	Degrees (from True North)	360°	+/-5°
Ambient air temperature at MMT (hub height)	Temperature probe	°C	-20 to +50 °C	+/-1 °C
Ambient air pressure at MMT (hub height)	Piezoresistive transducer, barometer or equivalent	Mbar	150 to 1150 mbar	+/-60 mbar (0 to +50°C)
Power production of Facility	Measured at POI	MW		+/- 0.1 MW
Power Possible	Seller's Model	MW	0 to 120% of Allowed Capacity	+/- 0.1 MW

(iv) Status of Generating Equipment:

For each inverter, or wind turbine, Seller shall provide to Company, via SCADA communication and protocol acceptable to Company at a continuous scan updated not less frequently than every 2 seconds, a signal as to whether such inverter is available or unavailable, and on or offline.

(v) Data Collection.

[NOTE COMPANY TO UPDATE REQUIREMENTS; WILL BE SPECIFIC TO FACILITY EQUIPMENT AND RESOURCE TYPE]

High Resolution Data: Seller shall install and make available to the Company time stamped and sequential data recordings for all inverter-based resources (and all generating resources) to perform event analysis and verify Facility performance during steady state and transient disturbance events. This will include a time-synchronized phasor measurement unit at the Facility, and access to multiple sources to provide sufficient clarity as to any abnormal response or behavior within the Facility, including Facility control settings and static values, SCADA data, sequence of events recording (SER) data, dynamic disturbance recorder (DDR) data, and inverter fault codes and inverter-level dynamic recordings. This data will be used to review the Facility response to system dynamics, such as the frequency response (normal droop and FFR), reactive response, etc.

Plant Data: **[Note: specific requirements below are representative of variable energy resources and will be tailored to the Facility resource type(s) and geographic arrangement]**

Seller shall install at least three (3) meteorological tower(s), spaced so as to provide the data points set forth below for the entire Facility. At least two months prior to the Commercial Operation Date, Seller shall deliver to Company a report showing (i) manufacturer, model and year of all energy equipment (panels, inverters, energy storage devices, turbine generators), and meteorological instrumentation, and (ii) the latitude and longitude of the center of the energy equipment (i.e., solar panels for every inverter, wind turbines) and every meteorological tower. Beginning upon COD, Seller

shall transmit and provide to Company the real-time data set forth below, refreshed as frequently as allowed by the SCADA system, not to exceed sixty (60) second intervals:

- Three (3) data points from each inverter or wind turbine:
 - Inverter/turbine generation (MW)
 - Inverter/turbine availability
 - Inverter/turbine on/offline status
- Two (2) data points from each meteorological tower (solar resources):
 - Global horizontal solar irradiance (instantaneous solar intensity, full sky)
 - Plane of array solar irradiance (instantaneous solar intensity at the current angle of the PV array)
- Five data points from each Meteorological Tower (wind resources):
 - Wind Speed ** (mps)
 - Wind Direction** (degrees relative to true north)
 - Temperature (Celsius)
 - Pressure (mb)
 - Air Density (kg/m3)

In addition to the other requirements for data collection, if required by Company, a Facility with wind turbines shall install, maintain and operate at least one meteorological tower that is installed at hub height and is placed upstream of the prevailing wind path to provide meteorological data through a means agreed by the Company. The data stream from this meteorological tower to the Company's System must be reliable and include battery back-up at the meteorological tower and a local source of electricity to power the data collection and communication from the Facility to Company during transmission outages.

Seller shall provide a map and key for each inverter or wind turbine sufficient to allow

Company to correlate the data received through Company's data historian system to each individual resource.

9. Technology Specific Requirements.

(a) [RESERVED]

(b) [RESERVED]

(c) Inverter Systems.

(i) Direct current generators and non-power (i.e., other than 60 Hertz) alternating current generators can only be installed in parallel with the Company System using a non-islanding synchronous inverter unless alternate designs are approved by the Company. The design shall comply with the requirements of IEEE Std 1547-2003 (or latest version), except as described in Section 3 (Performance Standards) of this Attachment B (Facility Owned by Seller).

(ii) Self-commutated inverters of the Company-interactive type shall synchronize to the Company System. Line-commutated, thyristor-based inverters are not recommended and will require additional technical study to determine harmonic and reactive power requirements. All interconnected inverter systems shall comply with the harmonic current limits of IEEE Std 519-1992 (or latest version).

(d) Battery Energy Storage System. The operating parameters of the BESS for facilities with paired storage shall be as follows:

(i) For facilities with variable energy and paired storage: The BESS shall directly charge storage from the variable resource when the Company Active Power Dispatch is for less than the available resource energy.

(ii) No more than []% of the BESS energy capacity can be charged from the grid prior to the fifth (5th) anniversary of the Commercial Operations Date. Thereafter, 100% of the BESS energy capacity can be charged from the grid. **[DRAFTING]**

NOTE: 5-YEAR LIMITATION ON GRID CHARGING WILL BE DELETED IF ITC RECAPTURE IS NOT APPLICABLE TO THE BESS.]

- (iii) The BESS will not be required to discharge more energy than available relative to the available state of charge.
- (iv) For storage used primarily for energy shifting, the BESS shall be designed for an average annual use of 365 cycle(s) (a cycle is a discharge equal to the portion of the BESS Contract Capacity allocated for energy shifting, and sufficient charging to return the BESS to 100% State of Charge)
- (v) For contingency storage, the BESS storage technology shall be procured based on required charging/discharging duty for the provision of disturbance frequency response. This response will require fast response outside of a specified frequency deadband, in accordance with specified droop and time parameters. **(Historical frequency data for 2 second data resolution samples will be provided to bidders.) (Assumptions and associated restrictions on charging/discharging duty to be supplied by bidders).**

11. Operating Committee and Operating Procedures.

Company and Seller shall each appoint one representative and one alternate representative to act as the operating committee in matters relating to the Parties' performance obligations under this Agreement and to develop operating arrangements for the generation, delivery and receipt of renewable energy from the Facility.

The operating committee may develop mutually agreeable written operating procedures consistent with the requirements of this Agreement, to address matters such as day-to-day communications; key personnel; operations-center interface; metering, telemetering, telecommunications, and data acquisition procedures; operations and maintenance scheduling and reporting; reports; operations log; testing procedures; and such other matters as may be mutually agreed upon by the operating committee.

The operating committee shall review the requirements for Active Power Control, the data collection and telemetry, and control system parameters from time to time after the date hereof and may agree on modifications thereto to the extent necessary or convenient for operation of the Facility in accordance with this Agreement.

The operating committee shall have authority to act in all technical and day-to-day operational matters relating to performance of this Agreement and to attempt to resolve potential disputes, provided, however, that except as explicitly provided herein, the operating committee shall have no authority to amend or waive any provision of this Agreement.

EXHIBIT B-1
MODELING REQUIREMENTS

1. Steady State and Dynamic Model Requirements and As-built Data to be provided by Seller. The expected steady state power flow and dynamic models will be provided by the Seller during the interconnection study process in the format compatible with the analytical tools used by Company. Depending upon Facility design, different representations may be required for steady state and dynamic simulations. Seller will work with Company to derive a complex equivalent model if it is required to meet interconnection study needs. The as-built data and models will be provided by Seller immediately upon commissioning with sufficient information to demonstrate that the as-built parameters match the model. Any changes to plant settings that affect its response and impact to the Company System are required to be studied prior to those changes taking effect. The modeling will include all necessary control settings such that the correct capabilities, flags, and settings can be represented in a base case. Where such parameters are settable according to this Agreement, the initial models will be configured with parameters mutually agreed with Company for the interconnection study analysis. This includes, but is not limited to:
 - Plant Type: A description of the resource type (e.g., storage, solar PV or wind power resource) used as a flag to ensure that the inverter-based resource is accurately represented in the base case, where applicable.
 - Active and Reactive Capability: The overall plant "composite capability curve" shall be provided by Seller for performance purposes. That same curve will be used for accurately modeling the P-Q capability in power flow studies.
 - Plant-Level Voltage Control Settings: Information on the plant voltage control mode to ensure correct voltage control flags and set points are set accordingly in the software tools.
 - The voltage control set point at the POI is provided by the Company. Seller shall provide a description of the coordination of any plant-level shunt compensation

(static or dynamic) to ensure it can be accurately represented in the power flow base case.

The models provided by Seller should accurately reflect the contractual requirements established under this Agreement.

2. Positive Sequence Stability Modeling. Seller shall provide a positive sequence stability model representation which provides sufficient detailed modeling for necessary reliability studies, as specified by Company. **[Note - language to be revised based on proposed Facility.]** For example, the following are typical requirements for plants with inverter equipment:
 - Inverter-Level Controller Model: This represents the overall control of the inverter as an energy or generating resource.
 - Electrical Control Model: This represents the detailed electrical controls of the resource, including large disturbance behavior.
 - Plant-Level Controller Model: This represents control of multiple individual inverters and/or generators within the plant
3. Short Circuit Modeling. Seller will provide appropriate and accurate models to Company to support short circuit studies. **[Company to specify requirements based on specific Facility]**
4. Electromagnetic Transient Modeling. Company will require an electromagnetic transient ("EMT") model for the Facility. Seller shall provide Company with an EMT model for the IRS and an updated EMT model after the Facility has been commissioned. These models are in addition to the positive sequence stability models required for interconnection-wide modeling purposes. In addition, Seller shall provide Company with evidence that the expected (and commissioned) EMT model reasonably matches the positive sequence dynamic models provided. This should include a benchmarking report provided by the inverter OEM.

EXHIBIT B-2
GENERATOR AND ENERGY STORAGE CAPABILITY CURVE(S)

**[ATTACHMENT C WILL BE REVISED TO REFLECT
THE RESULTS OF IRS]**

ATTACHMENT C
METHODS AND FORMULAS FOR MEASURING PERFORMANCE STANDARDS

1. Performance Standards as defined below shall be used, in part, to govern actions by Company to limit the Actual Output of the Facility for purposes of maintaining power quality on Company System. Specific standards are defined for:
 - Ramp Rate (RR)
2. Formulas for measuring the performance standards are presented below, and assume that the power fluctuations will be monitored on the Company's SCADA and EMS systems. These formulas are based on the periodicity at which analog data is retrieved from Telemetry and Control. This periodicity is called the "scan rate". Company presently uses a two-second analog scan rate. The formulas below are based on the two-second scans. The two-second scan rate, characteristics of transducers and Telemetry and Control reporting, and SCADA method of calculation, were considered and included in the proposed values for the performance standards.
3. Ramp Rate Calculation:

$$RR = MW_s - MW_{s-30}$$

Where:

RR = Ramp Rate, may be calculated once every scan

MW_{s-30} = The instantaneous MW analog value 30 scans (60 seconds) prior the present scan

MW_s = The instantaneous MW analog value for the present scan

4. All changes in output shall be implemented as a ramp rate, and not with one or two step changes within the period. It is not acceptable, for example, for a two MW/minute ramp rate compliance, that all values be zero except for a 2 MW change in the last scan value.

ATTACHMENT D
CONSULTANTS LIST

ATTACHMENT E
SINGLE-LINE DRAWING AND INTERFACE BLOCK DIAGRAM

(To be attached as per Section 1(a) of Attachment B)

ATTACHMENT F
RELAY LIST AND TRIP SCHEME

(To be attached as per Section 1(a) of Attachment B.)

**[ATTACHMENT G SHALL BE REVISED TO REFLECT
THE RESULTS OF IRS]**

ATTACHMENT G
COMPANY-OWNED INTERCONNECTION FACILITIES

1. Description of Company-Owned Interconnection Facilities.

- (a) General. Company shall furnish or construct (or may have Seller furnish or construct, in whole or in part), own, operate and maintain all Interconnection Facilities required to interconnect Company System with Facility at [REDACTED] volts, up to the Point of Interconnection (collectively, the "Company-Owned Interconnection Facilities").
- (b) Site. Where any Company-Owned Interconnection Facilities are to be located on the Site, Seller shall provide, at no expense to Company, a location and access acceptable to Company for all such Company-Owned Interconnection Facilities, as well as an easement, license or right of entry to access such Company-Owned Interconnection Facilities. If power sources (120/240VAC) are required, Seller shall provide such sources, at no expense to Company.
- (c) IRS. An IRS addressing Facility requirements was completed for the Project in accordance with the IRS Letter Agreements, and the results have been incorporated in Attachment B (Facility Owned by Seller) and this Attachment G (Company-Owned Interconnection Facilities) as appropriate.
- (d) Seller's Payment Obligations. Company-Owned Interconnection Facilities, for which Seller has agreed to pay, whether designed, engineered and constructed by Seller or Company, include **[ADD LIST OF COMPANY-OWNED INTERCONNECTION FACILITIES THAT ARE REQUIRED PURSUANT TO THE RESULTS OF THE IRS. THE FOLLOWING IS AN EXAMPLE OF THE TYPES OF FACILITIES THAT COULD BE LISTED]:**
- (i) **[Line extension];**
- (ii) A manually operated, lockable, group operated switch located on a pole prior to the Facility switching station. Company will install a ____ kV drop into Seller-provided deadend structure.

- (iii) Substation additions and/or modifications of Company's existing structures as necessary. This would include but not be limited to protective relaying and setting changes;
 - (iv) Supervisory control and communications equipment (including but not limited to, SCADA/Telemetry and Control, microwave, satellite, dedicated phone line(s) and/or any other acceptable communications means (determined by Company), fiber optics, copper cabling, installation of batteries and charger system, etc.);
 - (v) Revenue Metering Package as provided in Section 10.1 (Meters) of the Agreement;
 - (vi) Any additional Interconnection Facilities needed to be installed as a result of final determination of Facility switching station site, final design of Facility to enable Company to complete the Interconnection Facilities and be compatible with Good Engineering and Operating Practices.
 - (vii) If equipment that is not standard to Company is utilized, Seller shall, at the discretion of Company, provide adequate spares.
- (e) Revisions to Costs. The list of Company-Owned Interconnection Facilities, and engineering and testing costs for Company-Owned Interconnection Facilities, for which Seller agrees to pay in accordance with this Attachment G (Company-Owned Interconnection Facilities), are subject to revision if (i) before approving this Agreement, the PUC approves a power purchase agreement for another non-Company owned electric generating facility ("Second NUG Contract") to supply electric energy to Company using the same line to which Facility is to be connected or (ii) the line to which Facility is to be connected and/or the related transformer(s) need(s) to be upgraded and/or replaced as a result of this Agreement and a Second NUG Contract, and the PUC, in approving this Agreement, determines that Seller should pay for all or part of the cost of such upgrade and/or replacement.
- (f) Review of the Listing and Costs. If the Commercial Operations Date is not achieved by the Guaranteed Commercial Operations Date, as such date may be extended

as provided in Section 13.3 (Guaranteed Project and Reporting Milestone Dates), the listing of the Company-Owned Interconnection Facilities required in this Agreement and the cost-estimates for such Company-Owned Interconnection Facilities are subject to review and revision. Such revision may include, but not be limited to, such items as reconductoring an existing transmission or distribution line, construction of a new line, increase transformer capacity, and alternative relay specifications. In addition, such review and revision may require that the Company re-perform or update the IRS at the Seller's expense.

- (g) Responsibility of Seller and Company. The general responsibilities of Seller and Company for the design, procurement, installation, programming/testing, and maintenance/ownership of equipment at the Facility and the Company-Owned Interconnection Facilities is specified in Matrix G-1 (Substation Responsibilities) and Matrix G-2 (Telecom Responsibilities). **[DRAFTING NOTE: MATRIXES WILL BE UPDATED FOLLOWING COMPLETION OF IRS.]**

2. Construction and Support Services By Seller.

(a) Construction and Support Services By Seller.

(i) Seller (and/or its Third Party consultants or contractors (collectively, "Contractors")) will design, engineer, construct, test and place in service, at Seller's expense:

- A. The items identified in Matrix G-1 (Substation Responsibilities) and Matrix G-2 (Telecom Responsibilities) as being the responsibility of Seller to construct; and
- B. **[ANY OTHER COMPANY-OWNED INTERCONNECTION FACILITIES TO BE CONSTRUCTED BY SELLER].**
[NOTE: SUBPARTS "A" AND "B" BETWEEN THEM SHOULD GENERALLY INCLUDE A SUBSET OF THE LIST IN SECTION 1(d) ABOVE]

All design, engineering and construction performed by Seller (and/or its Contractors) shall, without

limitation, satisfy the wind load and seismic load requirements of the International Building Code and any more stringent requirements imposed under applicable Laws.

(ii) Seller shall provide the necessary support for the Company's [REDACTED] kV overhead line extension work, which may include, but not limited to:

- A. Furnish surveyed topographical drawing including contour lines of project areas and beyond as needed in State Plane coordinates with overlay of the Facility and Company pole line route(s) indicating pole locations and anchors in CADD format acceptable to Company.
- B. Staking of Company proposed poles and anchors by surveyor.
- C. Graded access roads including gravel if required by Company to provide sufficient vehicle access to Company poles and anchors by Company trucks and cranes.
- D. Graded level pads to provide vehicle working areas around all Company poles and anchors.
- E. Grading of the areas beneath the Company's overhead lines as needed to provide required ground clearance.
- F. Grubbing and clearing of vegetation within Company's easement area or as required.

(b) Coordination of Construction. Prior to Seller engaging the Contractors, Seller shall obtain Company's written approval, which approval shall not be unreasonably withheld. Prior to Seller and/or its Contractors first starting to work on the construction plans for Company-Owned Interconnection Facilities to be constructed by Seller (and/or its Contractors), such as the civil, structural, and construction drawings, specifications to vendors, vendor approved final drawings and materials lists (collectively, the "Plans"), Seller and/or its Contractors shall meet with Company to discuss the construction of such Company-Owned Interconnection Facilities, including but not limited to subjects concerning coordination of construction milestone dates,

agreement on areas of interface design, and Company's design/drawing layout and symbols standards, equipment specifications and construction specifications and standards. Company will provide the equipment specifications and construction specifications and standards information so Seller can incorporate such information in its bid documents.

- (c) Plans. Seller shall provide Company its complete Plans at 30%, 60% and 90% completion. No later than sixty (60) Days before Seller and/or its Contractors first start to order materials and equipment for Company-Owned Interconnection Facilities to be constructed by Seller and/or its Contractors, Seller shall provide Company with the final Plans. The Plans for Company-Owned Interconnection Facilities to be constructed by Seller (and/or its Contractors) shall comply with (i) all applicable Laws; (ii) Company's design/drawing layout and symbol standards, equipment specifications, and construction specifications and standards; and (iii) Good Engineering and Operating Practices (collectively, the "Standards"). Seller shall submit design drawings in MicroStation format per Company standards.
- (i) Company's Review of the Plans. Unless otherwise agreed to by the Parties, Company shall have thirty (30) Days following receipt of the complete Plans at each stage (30%, 60%, 90% and final) for it to review and comment on the Plans, and verify in writing to Seller that the Plans comply with the Standards, which verification shall not be unreasonably withheld. If Company reasonably determines that the Plans are not in accordance with the Standards, then it may request in writing a response from Seller to its comments and Seller shall respond in writing within thirty (30) Days of such request by providing (i) its justification for why its Plans conform to the Standards or (ii) changes in the Plans responsive to Company's comments and in accordance with the Standards.
- (j) Company Inspection. Construction work will be subject to Company inspections to ensure that construction is done in accordance with the Standards. Company inspectors will be allowed access to the construction sites for inspections and to monitor construction work. The inspector shall have the authority to work with the appropriate construction supervisor to stop any work

that does not meet the Standards. All equipment and materials used in Company-Owned Interconnection Facilities to be constructed by Seller and/or its Contractors shall meet the Standards.

(k) Acceptance Test Procedures.

- (i) Seller acknowledges that: (aa) Company has multiple on-going projects with other developers as well as its own capital improvement projects; (bb) Company has limited resources to provide engineering oversight (such as review of plans) to such projects and to participate in the testing of such projects; (cc) in order for Company to accommodate such oversight and testing, it is necessary for Company to sequentially allocate its resources for each project a year or more in advance; (dd) the result is a queue of such projects that reflects the scheduling commitments of Company's resources to conduct such oversight and to participate in such testing; (ee) if a project is behind the schedule on which Company's resources have been scheduled for the oversight of such project, or if a project is not ready for testing at the time Company's resources have been scheduled for the testing of such project, or if a project does not complete testing within the period for which Company's resources have been scheduled for such testing, the progress of projects later in the queue may be adversely affected; (ff) the Test Ready Deadline that is set forth in Attachment K-1 (Seller's Conditions Precedent and Company Milestones) reflects the scheduling commitment of Company's resources to (i) conduct the oversight necessary to facilitate Seller's achievement of that Test Ready Deadline, (ii) commence the Acceptance Test on the Acceptance Testing Milestone Date that is set forth in Attachment K-1 (Seller's Conditions Precedent and Company Milestones) and (iii) thereafter participate in the Control System Acceptance Test; and (gg) the Project will lose its place in the queue and will be assigned a new Acceptance Testing Milestone Date for commencement of the Acceptance Test that will be behind the other projects then in the queue if (i) the Seller fails to satisfy any of the conditions precedent set forth in Section 2(f)(ii) of this Attachment G

(Company-Owned Interconnection Facilities) within the time period specified therein for the task in question or, if no time period is specified therein, by the Test Ready Deadline, (ii) the Seller fails to satisfy any of the Seller's Conditions Precedent set forth in Attachment K-1 (Seller's Conditions Precedent and Company Milestones) and/or (iii) the Acceptance Test and the Control System Acceptance Test are not satisfactorily completed within the time allotted to complete such testing.

(ii) The Conduct of the Acceptance Test is subject to the satisfaction of the following conditions precedent within the time period specified below for the task in question or, if no time period is specified, by the Test Ready Deadline that is set forth in Attachment K-1 (Seller's Conditions Precedent and Company Milestones):

- Final Single-Line Drawing, and notes, has received Company's written consent pursuant to Section 1(a)(i) (Single-Line Drawing, Interface Block Diagram, Relay List, Relay Settings and Trip Scheme) of Attachment B (Facility Owned by Seller) to this Agreement.
- Final Relay List and Trip Scheme have received Company's written consent pursuant to Section 1(a)(i) (Single-Line Drawing, Interface Block Diagram, Relay List, Relay Settings and Trip Scheme) of Attachment B (Facility Owned by Seller) to this Agreement.
- Final Interface Block Diagram has received Company consent pursuant to Section 1(a)(i) (Single-Line Drawing, Interface Block Diagram, Relay List, Relay Settings and Trip Scheme) of Attachment B (Facility Owned by Seller) to this Agreement.
- Final Control System Telemetry and Control List has received Company consent.
- Final phasor measurement unit (PMU) devices, if applicable, have received Company consent.
- Control system design and tunable parameters reviewed and mutually agreed upon as needed to

meet the Company requirements in accordance with Attachment B (Facility Owned by Seller) Performance Standards.

- Agreement on Active Power Control Interface.
- No later than 14 Days prior to commencement of the Acceptance Test:
 - Seller shall have certified to Company that Seller-Owned Interconnection Facilities have been installed and commissioned and such certification has not, prior to the commencement of the Acceptance Test, been subsequently challenged by Company on the basis of on-site observations made by the Company's representatives following the walk-through to be conducted pursuant to Section 2(f)(iii) of this Attachment G (Company-Owned Interconnection Facilities).
 - Seller shall have certified to Company that any Company-Owned Interconnection Facilities built by Seller (and/or its Contractors) have been installed and commissioned and such certification has not, prior to the commencement of the Acceptance Test, been subsequently challenged by Company on the basis of on-site observations made by the Company's representatives following the walk-through to be conducted pursuant to Section 2(f)(iii) of this Attachment G (Company-Owned Interconnection Facilities).
- Any Company-Owned Interconnection Facilities not built by or on behalf of Seller have been installed and commissioned.
- No later than 7 Days prior to the commencement of the Acceptance Test, Seller and Company shall have participated in walk-through of fully constructed Interconnection Facilities.
- Redlined as-built drawings of the Seller-Owned Interconnection Facilities and any of the Company-Owned Interconnection Facilities built by Seller (and/or its Contractors) shall have been provided to Company.

- Continuous power is being supplied to Company's protection and SCADA equipment.
- Not less than four (4) weeks prior to the commencement of the Acceptance Test, the high speed communication lines required under this Agreement have been commissioned and are ready for use.
- Not less than two (2) weeks prior to the commencement of the Acceptance Test, Seller and Company have participated in an on-Site Acceptance Test coordination meeting.

(iii) Seller shall provide Company with at least fourteen (14) Days advance written notice of the commencement of the Acceptance Test. The Acceptance Test will be conducted on Business Days during normal business hours and may take a minimum of 30 Days to complete. No electric energy will be delivered from Seller to Company during the Acceptance Test. No later than thirty (30) Days prior to conducting the Acceptance Test, Company and Seller shall agree on a written protocol setting out the detailed procedure and criteria for passing the Acceptance Test. Attachment N (Acceptance Test General Criteria) provides general criteria to be included in the written protocol for the Acceptance Test. At the time that Seller provides its 14-Day notice of the Acceptance Test to Company, Seller shall concurrently schedule a site walk-through of the Facility with Company to occur no later than seven (7) Days prior to the Acceptance Test. Seller's 14-Day notice to Company of the Acceptance Test shall constitute its certification that (i) the completion of the installation and commissioning of the Seller-Owned Interconnection Facilities and the Company-Owned Interconnection Facilities built by Seller (and/or its Contractors) and (ii) a walk-through by Company shall demonstrate, to Company's reasonable satisfaction, Seller's readiness to commence with the Acceptance Test. If, after the site walk-through, Company representatives reasonably determine that Seller is not ready to commence with the Acceptance Test, the Project will lose its place in the queue and will be assigned a new Test Ready Deadline and a new Acceptance Testing

Milestone Date that will be behind the other projects then in the queue. In the meantime, Seller shall remediate the deficiencies identified by Company, and the process described in this Section 1(f) (Acceptance Test Procedures) of Attachment G (Company-Owned Interconnection Facilities), shall commence again until Seller's readiness for the Acceptance Test is demonstrated to Company's reasonable satisfaction. Successful completion of the Acceptance Test requires successful completion of each of the individual tests that comprise the Acceptance Test. Retesting of any individual test constitutes as restart of the Acceptance Test if such retesting is required because of a prior failure of such individual test or because of a prior test could not be completed because of a problem with the Facility. Within fifteen (15) Business Days of completion of the Acceptance Test and Company's receipt of the final report setting forth the results of the Acceptance Test, Company shall notify Seller in writing whether the Acceptance Test has been passed and, if so, the date upon which the Acceptance Test was passed.

- (iv) Company will be present when the Acceptance Test is conducted, and Seller shall promptly correct any deficiencies identified during the Acceptance Test. Seller will be responsible for the cost of Company personnel (and/or Company contractors) performing the duties (such as reviewing the Plans and reviewing the construction) necessary for Company-Owned Interconnection Facilities to be constructed by Seller (and/or its Contractors). If Company (i) does not make any inspection or test, (ii) does not discover defective workmanship, materials or equipment, or (iii) accepts Company-Owned Interconnection Facilities (that were constructed by Seller and or its Contractors), such action or inaction shall not relieve Seller from its obligation to do and complete the work in accordance with the Plans approved by Company.

- (1) As-Built Drawings. Within thirty (30) Days of the successful completion of the Acceptance Test, Seller shall provide for Company review a set of the proposed as-built drawings for the Company-Owned Interconnection

Facilities constructed by Seller (and/or its Contractors). Within thirty (30) Days of Company's receipt of the proposed as-built drawings, Company shall provide Seller with either (i) its comments on the proposed as-built drawings or (ii) notice of acceptance of the proposed as-built drawings as final as-built drawings. If Company provides comments on the proposed as-built drawings, Seller shall incorporate such comments into a final set of as-built drawings and provide such final as-built drawings to Company within twenty (20) Days of Seller's receipt of Company's comments.

3. Seller Payment To Company for Company-Owned Interconnection Facilities and Review Of Facility.

(a) Seller Payment to Company.

(i) Seller shall pay the Total Estimated Interconnection Cost, which is comprised of the estimated costs of (aa) acquiring, constructing and installing the Company-Owned Interconnection Facilities to be designed, engineered and constructed by Company, (bb) the engineering and design work (including but not limited to Company, affiliated Company and contracted engineering and design work) associated with (i) the application process for the PUC Approval Order, (ii) developing such Company-Owned Interconnection Facilities and (iii) reviewing and specifying those portions of Facility which allow interconnected operations as such are described in Attachment B (Facility Owned by Seller) (collectively, the "Engineering and Design Work"), and (cc) conducting the Acceptance Test and Control System Acceptance Test. The Total Actual Interconnection Cost (the actual cost of items (aa) through (cc)) are the "Total Interconnection Cost".

(ii) Summary List of Company-Owned Interconnection Facilities and Related Services to be designed, engineered and constructed by Company:

[THIS LIST SHOULD GENERALLY INCORPORATE A SUBSET OF THE LIST IN ATTACHMENT G, SECTION 1(d), PLUS TESTING.]

(iii) The following summarizes the Total Estimated Interconnection Cost of the Company-Owned Interconnection Facilities to be designed, engineered and constructed by Company:

[THIS LIST SHOULD INCLUDE ESTIMATED COSTS FOR THE ITEMS LISTED IN ATTACHMENT G, SECTION 3(a)(ii).]

The Total Estimated Interconnection Cost is \$.

(b) Total Estimated Interconnection Costs. The Total Estimated Interconnection Cost, which, except as otherwise provided herein, is non-refundable, shall be paid in accordance with the following schedule:

(i) Initial Payment: Prior to the execution of the Interconnection Requirements Amendment, Seller has paid \$____,000.00 to Company;

(ii) Company-Owned Interconnection Facilities Prepayment: Within thirty (30) Days after the execution of the Interconnection Requirements Amendment, the total estimated costs related to the Engineering and Design Work are due and payable by Seller to Company;

A. Company shall not be obligated to perform any work with respect to Company-Owned Interconnection Facilities until Seller pays the amounts in Section 3(b)(i) (Initial Payment) and Section 3(b)(ii) (Company-Owned Interconnection Facilities Prepayment) of this Attachment G (Company-Owned Interconnection Facilities), and receipt of such payment shall constitute Seller's irrevocable authorization to Company to perform such engineering and design work.

(iii) Balance of Company-Owned Interconnection Facilities Prepayment: On the Guaranteed Procurement Payment Date, the difference between the portion of the Total Estimated Interconnection Cost paid to date and the Total Estimated Interconnection Cost is due and payable by Seller to Company.

A. Company shall not be obligated to perform any work with respect to Company-Owned

Interconnection Facilities until Seller pays the amount in this Section 3(b)(iii) (Balance of Company-Owned Interconnection Facilities Prepayment) of this Attachment G (Company-Owned Interconnection Facilities), and receipt of such payment shall constitute Seller's irrevocable authorization to Company to perform such procurement and construction work.

- (c) True-Up. The final accounting shall take place within one hundred twenty (120) Days of the first to occur of (i) the Commercial Operations Date, (ii) the date this Agreement is declared null and void under either Section 12.5 (Prior to Effective Date) or Section 12.6 (Time Periods for PUC Submittal Date and PUC Approval) of this Agreement, or (iii) the date this Agreement is terminated, whichever occurs first. Company shall be entitled to an extension for a commercially reasonable amount of time to complete the final accounting if a delay in such completion is caused by Seller's delay or failure to respond to any Company request for information needed to complete the final accounting or take any action necessary for Company to complete the final accounting. Upon completion of the final accounting, Company shall deliver to Seller an invoice for payment of the amount, if any, of the difference between the Total Estimated Interconnection Cost paid to date and the Total Actual Interconnection Cost, which is the final accounting of the Total Interconnection Costs. Payment of such invoice shall be made within thirty (30) Days of receipt of such invoice from Company. If the Total Actual Interconnection Cost is less than the payments received by Company as the Total Estimated Interconnection Cost, Company shall repay the difference to Seller within thirty (30) Days of the final accounting.
- (d) Audit Rights. Seller shall have the right for a period of one (1) year following receipt of the invoice: (i) upon reasonable prior notice, to audit the books and records of Company to the limited extent reasonably necessary to verify the basis for the amount (if any) by which the Total Actual Interconnection Cost invoiced to Seller exceeds the Total Estimated Interconnection Cost, and (ii) to dispute the amount of any such excess. Seller shall not have the right to audit any other

financial records of Company. Company shall make such information available during normal business hours at its offices in Hawai'i. Seller shall pay Company's reasonable actual, verifiable costs for such audits, including allocated overhead.

- (e) Ownership. All Company-Owned Interconnection Facilities including those portions, if any, provided, or provided and constructed, by Seller shall be the property of Company.

4. Ongoing Operation and Maintenance Charges.

- (a) Prior to the Transfer Date. Seller shall operate and maintain, at its sole cost and expense, Company-Owned Interconnection Facilities that it or its Contractors constructed, if any, prior to the Transfer Date.
- (b) On or After the Transfer Date. On and after the Transfer Date, Company shall own, operate and maintain Company-Owned Interconnection Facilities.
- (c) Monthly Bill. Company shall bill Seller monthly (or periodically as costs are incurred) for any reasonable costs incurred in operating, maintaining and replacing (to the extent not covered by insurance) Company-Owned Interconnection Facilities. Company's costs will be determined on the basis of, but not limited to, direct payroll, material costs, applicable overhead at the time incurred, consulting fees and applicable taxes. Seller shall, within thirty (30) Days after receipt of an invoice, reimburse Company for such monthly billed operation and maintenance charges. Company's invoice will include itemized charges reasonably necessary for Seller to verify the basis for such charges.

5. Relocation of Company-Owned Interconnection Facilities.

- (a) In the event that the Land Rights include a relocation clause and such clause is exercised or if Company-Owned Interconnection Facilities must be relocated for any other reason not caused by Company, Seller shall bear the cost of such relocation. Prior to the relocation of the Company-Owned Interconnection Facilities Company shall invoice Seller for the total estimated cost of relocating the Company-Owned Interconnection Facilities (the "Total Estimated Relocation Cost"). Seller shall,

within thirty (30) Days after the invoice date, pay to Company the Total Estimated Relocation Cost.

- (b) Once the relocation of the Company-Owned Interconnection Facilities is complete, Company shall conduct a final accounting of all costs related thereto. Within thirty (30) Days of the final accounting, which shall take place within one hundred and twenty (120) Days of completion of the relocation of Company-Owned Interconnection Facilities, Seller shall remit to Company the difference between the Estimated Relocation Cost paid to date and the total actual relocation cost incurred by Company (the "Total Actual Relocation Cost"). If the Total Actual Relocation Cost is less than the payments received by Company as the Total Estimated Relocation Cost, Company shall repay the difference to Seller within thirty (30) Days of the final accounting.

6. Guarantee for Interconnection Costs.

- (a) Standby Letter of Credit. To ensure payment by Seller of all costs and expenses incurred by Company (i) in excess of the Total Estimated Interconnection Cost paid in connection with the Company-Owned Interconnection Facilities to be provided and/or constructed by Company described in Section 3 (Seller Payment To Company for Company-Owned Interconnection Facilities and Review Of Facility) of this Attachment G (Company-Owned Interconnection Facilities), and (ii) if applicable, in excess of the Total Estimated Relocation Costs paid in connection with the relocation of the Company-Owned Interconnection Facilities as provided in Section 5 (Relocation of Company-Owned Interconnection Facilities) of this Attachment G (Company-Owned Interconnection Facilities), Seller shall obtain an Irrevocable Standby Letter of Credit with no Documentary Requirement ("Standby Letter of Credit") in accordance with the requirements of Section 6(b) (Requirements of the Standby Letter of Credit) of this Attachment G (Company-Owned Interconnection Facilities), wherein Company shall receive payment from the bank upon request by Company.
- (b) Requirements of the Standby Letter of Credit. The Standby Letter of Credit shall be (i) in an amount not less than twenty-five percent (25%) of the Total Estimated Interconnection Cost or Total Estimated

Relocation Cost, as applicable, and (ii) in substantially in the form attached to this Agreement as Attachment M (Form of Letter of Credit) from a bank chartered in the United States with a credit rating of "A-" or better. If the rating (as measured by Standard & Poors) of the bank issuing the Standby Letter of Credit falls below A-, Company may require Seller to replace the Standby Letter of Credit with a Standby Letter of Credit from another bank chartered in the United States with a credit rating of "A-" or better. In connection with the construction of the Company-Owned Interconnection Facilities, the Standby Letter of Credit shall be effective from the earlier of (aa) thirty (30) Days following the Effective Date, or (bb) the date that Seller requests Company to order equipment or commence construction on Company-Owned Interconnection Facilities. In connection with the relocation of the Company-Owned Interconnection Facilities, if applicable, the Standby Letter of Credit shall be effective within thirty (30) Days after Seller receives the invoice from Company for the Total Estimated Relocation Cost as set forth in Section 5 (Relocation of Company-Owned Interconnection Facilities) of this Attachment G (Company-Owned Interconnection Facilities). The Standby Letter of Credit shall be in effect through the earlier of forty-five (45) Days after the final accounting or seventy-five (75) Days after the Agreement is terminated. Seller shall provide to Company within fourteen (14) Days of the date the Standby Letter of Credit is to be effective as aforesaid, a document from the bank which indicates that such a Standby Letter of Credit has been established.

- (c) Other Form of Security. Notwithstanding the foregoing, in lieu of a Standby Letter of Credit, Company may, at its sole discretion, agree in writing to accept such other form of security as Company deems to provide Company with protection equivalent to a Standby Letter of Credit.

7. Land Restoration.

- (a) Definition of "Land". For the purposes of this Attachment G (Company-Owned Interconnection Facilities), "Land" means any portion of the Site and any other real property where any Company-Owned Interconnection Facilities are located.

- (b) Removal of Interconnection Facilities. After termination of this Agreement or in the event this Agreement is declared null and void under either Section 12.5 (Prior to Effective Date) or Section 12.6 (Time Periods for PUC Submittal Date and PUC Approval) of this Agreement, if requested by Company, Seller shall, at its sole cost and expense, remove (i) the Company-Owned Interconnection Facilities from the Land and (ii) the Seller-Owned Interconnection Facilities from the Land, and, in conjunction with such removal, shall develop and implement a program to recycle, to the fullest extent possible, or to otherwise properly dispose of, all such removed infrastructure; provided, however, that, Company may elect to remove all or part of the Company-Owned Interconnection Facilities and/or Seller-Owned Interconnection Facilities from the Land because of operational concerns over the removal of such Interconnection Facilities, in which case Seller shall reimburse Company for its costs to remove such Company-Owned Interconnection Facilities and/or Seller-Owned Interconnection Facilities. To the extent Seller is obligated to remove Company-Owned Interconnection Facilities and/or Seller-Owned Interconnection Facilities, Seller shall complete such removal within ninety (90) Days of termination of this Agreement (or declaration that the Agreement is null and void under either Section 12.5 (Prior to Effective Date) or Section 12.6 (Time Periods for PUC Submittal Date and PUC Approval) of this Agreement, or as otherwise agreed to by both Parties in writing.
- (c) Restoration of the Land. After the termination of this Agreement (or declaration that the Agreement is null and void under either Section 12.5 (Prior to Effective Date) or Section 12.6 (Time Periods for PUC Submittal Date and PUC Approval) of this Agreement) and removal of the Company-Owned Interconnection Facilities and/or Seller-Owned Interconnection Facilities, as the case may be, Seller shall, at its sole cost and expense, restore the Land to its condition prior to construction of such Company-Owned Interconnection Facilities and/or Seller-Owned Interconnection Facilities, as applicable. Land restoration shall be completed within ninety (90) Days of termination of this Agreement (or declaration that the Agreement is null and void under either Section 12.5 (Prior to Effective Date) or Section 12.6 (Time Periods for PUC Submittal Date and PUC Approval) of this

Agreement), or as otherwise agreed to by both Parties in writing.

8. Transfer of Ownership/Title.

- (a) Transfer of Ownership and Title. On the Transfer Date, Seller shall transfer to Company all right, title and interest in and to Company-Owned Interconnection Facilities to the extent such facilities were designed and constructed by Seller and/or its Contractors together with (i) all applicable manufacturers' or Contractors' warranties which are assignable and (ii) all Land Rights necessary to own, operate and maintain Company-Owned Interconnection Facilities on and after the Transfer Date. Seller shall provide a written list of the manufacturers' and Contractors' warranties which will be assigned to Company and the expiration dates of such warranties no later than thirty (30) Days before the Transfer Date.
- (b) No Liens or Encumbrances. Company's title to and ownership of Company-Owned Interconnection Facilities that were designed and constructed by Seller and/or its Contractors shall be free and clear of liens and encumbrances.
- (c) Form of Documents. The transfers to be made to Company pursuant to this Section 8 (Transfer of Ownership/Title) of Attachment G (Company-Owned Interconnection Facilities) shall not require any further payment by Company. The form of the document to be used to convey title to the Company-Owned Interconnection Facilities that were designed and constructed by or on behalf of Seller shall be substantially in the form set forth in Attachment H (Form of Bill of Sale and Assignment). The form of the document(s) to be used to assign leases shall be substantially in the form set forth in Attachment I (Form of Assignment of Lease and Assumption). To the extent Land Rights other than leases are transferred to Company, appropriate modifications will be made to Attachment I (Form of Assignment of Lease and Assumption) to effectuate the transfer of such Land Rights.

9. Governmental Approvals for Any Company-Owned Interconnection Facilities.

Seller shall obtain at its sole cost and expense all Governmental Approvals necessary to the construction, ownership, operation and maintenance of the Company-Owned Interconnection Facilities. For Company-Owned Interconnection Facilities to be constructed by Company, Seller shall provide all Governmental Approvals necessary for the construction of such Company-Owned Interconnection Facilities prior to the commencement of construction by Company. For Company-Owned Interconnection Facilities to be constructed by Seller, Seller shall obtain all Governmental Approvals necessary for construction of the Company-Owned Interconnection Facilities prior to commencement of the construction activity for which such Governmental Approval is required. For all other Governmental Approvals for Company-Owned Interconnection Facilities, Seller shall provide these prior to the Transfer Date. On or before the Transfer Date, Seller shall provide Company with (i) copies of all such Governmental Approvals obtained by Seller regarding the construction, ownership, operation and maintenance of Company-Owned Interconnection Facilities that Seller and/or its Contractors constructed and (ii) documentation regarding the satisfaction of any condition or requirement set forth in any Governmental Approvals for Company-Owned Interconnection Facilities (excluding on-going reporting or monitoring requirements that may continue beyond the Transfer Date in accordance with such Governmental Approval) or that such Governmental Approvals have otherwise have been closed with the issuing Governmental Authority.

10. Land Rights.

Seller shall, prior to the commencement of construction of the Company-Owned Interconnection Facilities (whether to be built by Seller or by Company) obtain at its sole cost and expense all Land Rights that are required to construct, own, operate and maintain the Company-Owned Interconnection Facilities. Without limitation to the preceding sentence, Seller shall pay all surveying and mapping costs, appraisal fees, document preparation fees, recording fees or other costs. Seller shall use commercially reasonable efforts to obtain on behalf of the Company perpetual Land Rights for the Company-Owned Interconnection Facilities. Such Land Rights shall contain terms and conditions which are acceptable to Company and the documents setting forth the Land Rights shall be provided in advance of execution to Company for its review and approval and shall be recorded if required by Company. Following the Execution Date, Seller shall provide as part of

the Monthly Progress Report the status of negotiations with landowner(s) regarding the Land Rights. Notwithstanding the foregoing, Company shall have the right in its sole discretion, at any time upon notice to Seller, to communicate directly with the landowner(s) and/or participate in the negotiations with landowner(s) for the Land Rights. For so long as Seller has the right under this Agreement to sell electric energy to Company, Seller shall pay for any rents and other payments due under such Land Rights that are associated with Company-Owned Interconnection Facilities.

11. Contracts for Company-Owned Interconnection Facilities.

For all contracts entered into by or on behalf of Seller for Company-Owned Interconnection Facilities to be designed, engineered and constructed, in whole or in part, by or on behalf of Seller, the following shall apply: (i) Company shall be made an intended third-party beneficiary of such contracts; and (ii) Company shall be provided with copies of such executed contracts, which may be redacted but only to the extent required to prevent disclosure of confidential or proprietary information of Seller or the counterparty to such agreement; provided, however, that such redactions may not conceal information that is necessary for the Company to determine and exercise Company's rights under such contracts as a third-party beneficiary.

[MATRIX TO BE INSERTED]

ATTACHMENT H
FORM OF BILL OF SALE AND ASSIGNMENT

THIS BILL OF SALE AND ASSIGNMENT ("Bill of Sale"), made as of the ____ day of _____, 20____, by _____ ("Transferor") and _____ ("Transferee").

W I T N E S S E T H:

1. Bill of Sale. In consideration of the mutual covenants and agreements of Transferor and Transferee under the Power Purchase Agreement for Renewable Dispatchable Generation between Transferor and Transferee dated _____, 20__ ("PPA") and other good and valuable consideration, the receipt and sufficiency of which are hereby acknowledged, Transferor does hereby sell, assign and transfer over to Transferee all of Transferor's right, title and interest, in and to (i) all the tangible personal property and fixtures (including but not limited to the items set forth in Schedule H-1 (Description of Tangible Personal Property and Fixtures) attached hereto and incorporated herein), that constitutes what is referred to as the "Company-Owned Interconnection Facilities to be installed by or on behalf of Seller" (or words to similar effect) as set forth in Attachment G (Company-Owned Interconnection Facilities) to the PPA between [**Transferor and Transferee**] and (ii) the intangible personal property (including but not limited to the intangible personal property set forth in Schedule H-2 (Description of Intangible Personal Property) attached hereto and incorporated herein) owned by Transferor and used or to be used in the ownership, operation and maintenance of the aforesaid tangible personal property, to the extent assignable by Transferor, including without limitation, certificates of occupancy, permits, licenses, transferable warranties and guaranties, instruments, documents of title, and general intangibles pertaining to the aforesaid intangible personal property.

2. Warranty of Title. Transferor hereby warrants to Transferee that Transferor is the legal owner of the aforesaid tangible personal property and the aforesaid intangible personal property (including but not limited to the property set forth in Schedule H-1 (Description of Tangible Personal Property and Fixtures) and Schedule H-2 (Description of Intangible Personal Property)), and that said property is being sold, assigned and transferred to Transferee free and clear of all liens and encumbrances.

3. Governing Law. This Bill of Sale shall be governed by, and construed and interpreted in accordance with, the laws of the State of Hawai'i.

**[Signatures for Bill of Sale and Assignment
Appear on the Following Page]**

IN WITNESS WHEREOF, Transferor and Transferee have executed this instrument on the day and year first above written.

a _____

By _____
Its _____

"Transferor"

a Hawai'i corporation

By _____
Its _____

By _____
Its _____

"Transferee"

SCHEDULE H-1
DESCRIPTION OF
TANGIBLE PERSONAL PROPERTY AND FIXTURES

SCHEDULE H-2
DESCRIPTION OF INTANGIBLE PERSONAL PROPERTY

Model RDG PPA (PV+BESS)
Hawai'i Electric Light Company, Inc.

LAND COURT SYSTEM

REGULAR SYSTEM

Return by Mail () Pickup () To:

Tax Map Key Nos.:

Total pages: _____

ATTACHMENT I
FORM OF ASSIGNMENT OF LEASE AND ASSUMPTION

THIS ASSIGNMENT is made as of this _____ day of _____, 20____, by _____, a _____, whose principal place of business and post office address is _____, hereinafter called the "Assignor," and _____, a Hawai'i corporation, whose principal place of business and post office address is _____, Honolulu, HI 968____, hereinafter called the "Assignee,"

W I T N E S S E T H:

THAT the Assignor, for and in consideration of the sum of TEN DOLLARS (\$10.00) and other good and valuable consideration to it paid by the Assignee, the receipt and sufficiency of which are hereby acknowledged, and of the covenants and agreements of the Assignee hereinafter contained and on the part of the Assignee to be faithfully kept and performed, does hereby sell, assign, delegate, transfer, set over and deliver unto the Assignee, and its successors and assigns, all of Assignor's right, title and interest in and to the lease described in Schedule 1 (the "Lease"); together with

all interests thereto appertaining, and together with the personal property located on the land thereby demised.

And all of the estate, right, title and interest of the Assignor in and to the land thereby demised, and all buildings, improvements, rights, easements, privileges and appurtenances thereunto belonging or appertaining or used, occupied and enjoyed in connection with said Lease and the land thereby demised.

TO HAVE AND TO HOLD the same unto Assignee and its successors and assigns, for and during the respective unexpired term of said Lease, and as to said personal property (if any) absolutely and forever.

AND, in consideration of the premises, the Assignor does hereby covenant with the Assignee that the Assignor is the lawful owner of the herein described real property; that said Lease is in full force and effect and is not in default; that said real property is free and clear of and from all liens and encumbrances, except for the lien of real property taxes not yet by law required to be paid; that the Assignor is the lawful owner of said personal property (if any) and that Assignor's title thereto is free and clear of and from all liens and encumbrances, that the Assignor has good right to sell and assign said real property and personal property (if any) as aforesaid; and, that the Assignor will WARRANT AND DEFEND the same unto the Assignee against the lawful claims and demands of all persons, except as aforesaid.

AND, in consideration of the foregoing, the Assignee does hereby promise, covenant and agree to and with the Assignor and to and with said the lessor under the Lease, that the Assignee will, effective as of and from the date of the execution and delivery of this instrument and during the residue of the term of said Lease, pay the rents thereby reserved as and when the same become due and payable pursuant to the provisions of said Lease, and will also faithfully observe and perform all of the covenants and conditions contained in said Lease which from and after the date hereof are or ought to be observed and performed by the lessee therein named, and will at all times hereafter indemnify and save harmless the Assignor from and against the nonpayment of said rent and the nonobservance or nonperformance of said covenants and conditions and each of them.

The terms "Assignor" and "Assignee", as and when used herein, or any pronouns used in place thereof, shall mean and include the masculine, feminine or neuter, the singular or plural number, individuals, partnerships, trustees or corporations and their and each of their respective successors, heirs, personal representatives, successors in trust and assigns, according to the context hereof. All covenants and obligations undertaken by two or more persons shall be deemed to be joint and several unless a contrary intention is clearly expressed elsewhere herein. The term "Lease", as and when used herein, means the lease or sublease demising the leasehold estate described in Schedule 1, together with all recorded amendments thereof, if any, whether or not listed in Schedule 1. The term "rent", as and when used herein, means and includes all rents, taxes, assessments and any other sums charged pursuant to the Lease.

This instrument may be executed in any number of counterparts, each of which shall be deemed an original, but all of which shall constitute one instrument binding on all the Parties hereto, notwithstanding that all the Parties are not signatory to the original or the same counterpart.

[Signatures for Assignment of Lease and Assumption are on following page.]

IN WITNESS WHEREOF, Company and Assignor have executed
this instrument as of the date first above written.

By _____
Name:
Title:

By _____
Name:
Title:

"Assignor"

By _____
Name:
Title:

By _____
Name:
Title:

"Assignee"

STATE OF HAWAI'I)
) SS:
CITY AND COUNTY OF HONOLULU)

On this ____ day of _____, 20__, before me personally appeared _____ and _____, to me known to be the persons described in and who executed the foregoing instrument, and acknowledged that such persons executed such instrument as the free act and deed of such persons and if applicable in the capacity shown, having been duly authorized to execute such instrument in such capacity.

(Official Stamp or Seal)

Signature: _____
Print Name: _____
Notary Public, State of Hawai'i

My commission expires: _____

NOTARY CERTIFICATION STATEMENT

Document Identification or
Description: _____

Doc. Date _____ No. of Pages: ____

Jurisdiction: _____ Circuit
(in which notarial act is performed)

(Official Stamp or Seal)

Signature of Notary _____ Date of Notarization and
Certification Statement

Printed Name of Notary _____

STATE OF HAWAII)
) SS:
CITY AND COUNTY OF HONOLULU)

On this ____ day of _____, 20__, before me personally appeared _____ and _____, to me known to be the persons described in and who executed the foregoing instrument, and acknowledged that such persons executed such instrument as the free act and deed of such persons and if applicable in the capacity shown, having been duly authorized to execute such instrument in such capacity.

(Official Stamp or Seal)

Signature: _____
Print Name: _____
Notary Public, State of Hawaii

My commission expires: _____

NOTARY CERTIFICATION STATEMENT

Document Identification or Description: _____

Doc. Date _____ No. of Pages: _____

Jurisdiction: _____ Circuit
(in which notarial act is performed)

Signature of Notary _____ Date of Notarization and Certification Statement

(Official Stamp or Seal)

Printed Name of Notary _____

SCHEDULE 1

- Description of Lease
- To Be Attached

ATTACHMENT J
COMPANY PAYMENTS FOR ENERGY, DISPATCHABILITY AND AVAILABILITY OF
BESS

1. Price for Purchase of Electric Energy. Commencing on the Commercial Operations Date, Company shall pay Seller for electric energy produced by the Facility and delivered to the Point of Interconnection in response to Company Dispatch in accordance with this Agreement at the rate of \$[_____] /MWh. Company shall not pay for electric energy delivered to the Point of Interconnection from the BESS to the extent such energy was originally taken from the grid to charge the BESS. If the BESS is delivering electric energy to the Point of Interconnection in response to Company Dispatch during a period in which a portion of the energy stored in the BESS is attributable to electric energy that was originally taken from the grid, the electric energy delivered to the Point of Interconnection from the BESS during such period shall be deemed to be produced by the Facility for purposes of the first sentence of this Section 1 (Price for Purchase of Electric Energy) until no portion of the energy stored in the BESS is attributable to the production of the Facility. **[DRAFTING NOTE: COMPANY WILL SEEK INPUT DURING THE NEGOTIATION PROCESS ON HOW TO ISOLATE THE ENERGY THAT IS NOT BE PAID FOR AND ANTICIPATES THAT WHATEVER SOLUTION IS ARRIVED AT WILL BE UNIFORM ACROSS ALL PAIRED RESOURCES PPAs.]**
2. Lump Sum Payment for Purchase of Dispatchability. Commencing on the Commercial Operations Date, Company shall pay Seller for the availability of the Facility's Net Energy Potential, subject to the Renewable Resource Variability, to respond to Company Dispatch in accordance with this Agreement, as well as for the BESS Services, a monthly Lump Sum Payment as calculated and adjusted as set forth in Section 3 (Calculation of Lump Sum Payment) of this Attachment J (Company Payments for Energy, Dispatchability and Availability of BESS). The monthly Lump Sum Payment shall be calculated and adjusted to reflect changes in the estimate of the Facility's Net Energy Potential as such estimate is revised from time to time as more fully set forth in Attachment U (Calculation and Adjustment of Net Energy Potential) to this Agreement.
3. Calculation of Lump Sum Payment. The monthly Lump Sum Payment shall be calculated and adjusted as follows:

- i. Lump Sum Payment During First Benchmark Period. During the First Benchmark Period, the monthly Lump Sum Payment shall be equal to one-twelfth (1/12th) of the product (rounded to the nearest cent) obtained by multiplying the Unit Price by the First NEP Benchmark.
- ii. Lump Sum Payment During Second Benchmark Period.
 - a. One purpose of the Second Benchmark Period is to provide the Seller, in the event that the Initial NEP OEPR Estimate is less than NEP RFP Projection, with a limited period during which Seller will have an opportunity, by having a Subsequent OEPR prepared pursuant to Section 3(b) (Voluntary Subsequent OEPR) of Attachment U (Calculation Adjustment of Net Energy Potential) to this Agreement, to obtain an adjustment to the NEP OEPR Estimate used to calculate the Lump Sum Payment, subject to (i) the cap on any upward adjustment imposed by the limitation that the estimate of Net Energy Potential that is used to calculate the Lump Sum Payment shall not exceed the NEP RFP Projection and (ii) the risk that any Subsequent OEPR might result in a downward adjustment to the NEP OEPR Estimate used to calculate the Lump Sum Payment. Accordingly, for each calendar month during the Second Benchmark Period, the monthly Lump Sum Payment shall be equal to one-twelfth (1/12th) of the product (rounded to the nearest cent) obtained by multiplying the Unit Price by the lesser of the (w) the NEP RFP Projection or (x) the NEP OEPR Estimate of the OEPR that is most recent as of the first Day of such calendar month. For avoidance of doubt:
 1. On the first Day of the Second Benchmark Period, the most recent OEPR will be the Initial OEPR;
 2. If no Subsequent OEPR is issued under Section 3 (Subsequent OEPRs) of Attachment U (Calculation and Adjustment of Net Energy Potential) to this Agreement for an OEPR Period of Record ending prior to the end of the third (3rd) Contract Year, the "most recent OEPR" during the entirety of the Second Benchmark Period will be the Initial OEPR;

3. If any Subsequent OEPR is prepared for an OEPR Period of Record ending prior to the commencement of the fourth (4th) Contract Year, the monthly Lump Sum Payment shall, for the period commencing on the first Day of the calendar month following the month during which an OEPR Evaluator issues such Subsequent OEPR, be equal to one-twelfth (1/12th) of the product (rounded to the nearest cent) obtained by multiplying the Unit Price by the lesser of (w) the NEP OEPR Estimate obtained from such Subsequent OEPR or (x) the NEP RFP Projection. The monthly Lump Sum Payment calculated as aforesaid shall remain in effect through the first to occur of (y) the end of the Term or (z) the end of the calendar month during which an OEPR Evaluator issues the next Subsequent OEPR (if any) that is required or permitted under Section 4 (Preparation of OEPR) of Attachment U (Calculation and Adjustment of Net Energy Potential) to this Agreement.

iii. Lump Sum Payment Following Second Benchmark Period.

- a. As of the first Day of the fourth (4th) Contract Year, the estimate of Net Energy Potential that was used to calculate the Lump Sum Payment for the last calendar month of the Second Benchmark Period shall continue in effect as the estimate of Net Energy Potential that is used to calculate the Lump Sum Payment until the end of the calendar month during which an OEPR Evaluator issues the first Subsequent OEPR for an OEPR Period of Record ending on or after the commencement of the fourth (4th) Contract Year and, effective at the end of such calendar month, the Second NEP Benchmark that was in effect immediately prior to the issuance of such Subsequent OEPR shall constitute the "Most Recent Prior NEP Benchmark" under clause (i) of the definition of that term set forth in this Agreement. For avoidance of doubt, if no Subsequent OEPR is issued for an OEPR Period of Record ending on or after the commencement of the fourth (4th) Contract Year, the Second NEP Benchmark that was used to calculate the Lump Sum Payment for the last calendar month of the Second Benchmark

Period shall continue in effect for the balance of the Term as the estimate of Net Energy Potential that is used to calculate the Lump Sum Payment.

- b. In order to facilitate planning for the Company System, no increase in Net Energy Potential (and hence in the monthly Lump Sum Payment) shall be permitted under this Agreement as a consequence of any Subsequent OEPR that is prepared for an OEPR Period of Record ending on or after the expiration of the Second Benchmark Period. Accordingly, if any such Subsequent OEPR is prepared, the monthly Lump Sum Payment shall, for the period commencing on the first Day of the calendar month following the month during which an OEPR Evaluator issues such Subsequent OEPR, be equal to one-twelfth ($1/12^{\text{th}}$) of the product (rounded to the nearest cent) obtained by multiplying the Unit Price by the lesser of (w) the NEP OEPR Estimate obtained from such Subsequent OEPR or (x) the Most Recent Prior NEP Benchmark. The monthly Lump Sum Payment calculated as aforesaid shall remain in effect through the first to occur of (y) the end of the Term or (z) the end of the calendar month during which an OEPR Evaluator issues the next following Subsequent OEPR (if any) that is required or permitted under Section 3 (Subsequent OEPRs) of Attachment U (Calculation and Adjustment of Net Energy Potential) to this Agreement. If any such next following Subsequent OEPR is issued, the monthly Lump Sum Payment shall, for the period commencing on the first Day of the calendar month following the calendar month during which an OEPR Evaluator issues such Subsequent OEPR, be re-calculated and adjusted as provided in this Section 3.iii.b of this Attachment J (Company Payments for Energy, Dispatchability and Availability of BESS) and shall continue in effect for the period provided in the preceding sentence.
- iv. Under the Company's previous forms of as-available power purchase agreements for renewable energy, the independent power producer was compensated for the production and delivery of electrical energy and assumed the risk of non-payment for events such as Force Majeure that prevented such production and delivery. Although under this Agreement most of Seller's compensation will

be in the form of a Lump Sum Payment rather than for the production and delivery of electrical energy, it is not the intent of the Parties that Seller should be entitled to unrestricted compensation in circumstances in which an independent power producer would not have been able to earn compensation under the Company's prior form of power purchase agreements (i.e., if the Facility or any portion thereof is unable to produce and deliver electric energy). Although the liquidated damages that are payable if the PV System Equivalent Availability Factor fails to satisfy the PV System Equivalent Availability Factor Performance Metric address this issue in certain of the circumstances when the PV System or a portion thereof is unable to generate electric energy, the PV System Equivalent Availability Factor does not account for events of Force Majeure because such events are included in the ExcludedTime classification under Section 2.5(a) (Calculation of the PV System Equivalent Availability Factor) of this Agreement. Accordingly, and without limitation to the generality of the foregoing provisions of this Section 3 (Calculation of Lump Sum Payment) of this Attachment J (Company Payments for Energy, Dispatchability and Availability of BESS), the monthly Lump Sum Payment shall be adjusted downward pro rata for each Day or portion thereof during the calendar month in question that the Facility inverter(s) or a portion thereof was not available to respond to Company Dispatch because of a Force Majeure condition (i) affecting the Facility or any portion thereof or (ii) that otherwise delays or prevents the Seller from making the Facility inverter(s) in question or a portion thereof available for Company Dispatch.

- v. Example 1: if a Facility has ten inverter(s) and, during the month of May (which has 31 calendar days), one inverter is not available to respond to Company Dispatch for a period of 15 Days due to a Force Majeure condition as aforesaid, the monetary amount of the resulting downward adjustment to the monthly Lump Sum Payment for the month of May would be calculated as follows:

$$\begin{array}{l} \text{Monetary Amount} \\ \text{of Downward} \\ \text{Adjustment} \end{array} = \begin{array}{l} (\text{MLSP} \times 1/10) \\ \times 15/31 \end{array}$$

where:

MLSP = The monthly Lump Sum Payment that would be payable for such month but for the downward adjustment.

For purposes of determining the monetary amount of the foregoing downward adjustment, the product obtained by multiplying a monetary value by a fraction shall be rounded to the nearest cent.

4. Test Energy. Company shall use reasonable efforts to accept test energy that is delivered as part of the normal testing for generators (such as energy delivered to Company during the Control System Acceptance Test but not during the Acceptance Test), provided Seller shall use reasonable efforts to coordinate such normal testing with Company so as to minimize adverse impacts on the Company System and operations. Company shall not compensate Seller for test energy.
5. Tax Credit Pass Through. Company acknowledges and agrees that the Federal Refundable Tax Credit and Federal Non-Refundable Tax Credit shall inure to the benefit of the Claiming Entity; provided, however, that Seller acknowledges and expressly agrees that the Federal Refundable Tax Credit and Federal Non-Refundable Tax Credit, with regard to Seller's Facility, have been calculated into the Contract Pricing based on the maximization of such credits. In the event that Seller's Facility does not gain the benefit of the Federal Refundable Tax Credit and/or the Federal Non-Refundable Tax Credit, Seller expressly acknowledges and agrees that it shall not seek to amend the Contract Pricing.
 - (a) Because the Hawai'i tax treatment that will apply to renewable energy technologies on the Commercial Operations Date is uncertain, the parties acknowledge that the Contract Pricing was set assuming Seller will not be eligible for any Hawai'i Renewable Energy Tax Credit. The intent of this Section 5 (Tax Credit Pass Through) is to entitle Company, for the benefit of its customers, to a payment equal to 100% of the maximum Hawai'i Renewable Energy Tax Credit for which Seller is eligible with respect to the Facility and receives during the Term, as more fully set forth in this Section 5 (Tax Credit Pass Through).
 - (b) If, as of the Commercial Operations Date, or, if not available at the Commercial Operations Date, at any subsequent time during the Term, a Hawai'i Refundable

Tax Credit is reasonably available to Seller or its Affiliates with respect to the Facility, the following shall apply:

- (i) Seller or Seller's Affiliate will apply for such Hawai'i Refundable Tax Credit, it being understood and agreed that if Seller applies for a Hawai'i Refundable Tax Credit as of the Commercial Operations Date, it shall have fulfilled its obligations hereunder to apply for the Hawai'i Refundable Tax Credit;
 - (ii) Seller shall make a payment to Company in an amount equal to one hundred percent (100%) of the Net Amount of such Hawai'i Refundable Tax Credit within thirty (30) Days after funds are received from the Hawai'i Department of Taxation;
 - (iii) Upon application for the Hawai'i Refundable Tax Credit, an officer of Seller will deliver to Company a notice (A) describing Seller's efforts to apply for and obtain the Hawai'i Refundable Tax Credit, (B) confirming that Seller has applied for the Hawai'i Refundable Tax Credit, and (C) certifying that Seller has used commercially reasonable efforts to apply for and obtain the maximum reasonably available Hawai'i Refundable Tax Credit as provided in this Section 5 (Tax Credit Pass Through);
 - (iv) Upon receipt of any funds from the Hawai'i Department of Taxation for the Hawai'i Refundable Tax Credit, an officer of Seller or an Affiliate of Seller, if applicable, will deliver a notice to Company certifying (A) the amount of funds received, (B) and the amount of payment that will be made to Company, net of federal tax and any documented and reasonable financial, legal, administrative, and other costs required to claim and transfer such funds to Seller, as supported by the officer's certificate as to the amount of such costs and the reasonableness thereof.
- (c) If, as of the Commercial Operations Date, a Hawai'i Refundable Tax Credit is unavailable, but a Hawai'i Non-Refundable Tax Credit is available to Seller or its Affiliates with respect to the Facility, or at any

subsequent time during the Term, a Hawai'i Non-Refundable Tax Credit becomes available to Seller or its Affiliates with respect to the Facility, notwithstanding that Seller may have applied for a Hawai'i Refundable Tax Credit, and in either case Seller can utilize, or enable its investors to utilize, such Hawai'i Non-Refundable Tax Credit, the following shall apply:

- (i) Seller or an Affiliate of Seller will apply for any available Hawai'i Non-Refundable Tax Credit, it being understood and agreed that if Seller applies for a Hawai'i Non-Refundable Tax Credit as of the Commercial Operations Date, it shall have fulfilled its obligations hereunder to apply for the Hawai'i Non-Refundable Tax Credit;
- (ii) Seller shall make a payment to Company in an amount equal to one hundred percent (100%) of the Net Amount of such Hawai'i Non-Refundable Tax Credit that Seller can utilize in the tax year in question within sixty (60) Days after the filing date of the applicable tax return for the tax year in which such Hawai'i Non-Refundable Tax Credit is utilized;
- (iii) Upon the filing of the applicable tax return(s), an officer of Seller or an Affiliate of Seller, if applicable, will deliver a notice to Company (A) describing Seller's efforts to apply for and obtain the Hawai'i Non-Refundable Tax Credit, (B) confirming that Seller has applied for the Hawai'i Non-Refundable Tax Credit, and (C) certifying that Seller has used commercially reasonable efforts to apply for and obtain the maximum reasonably available Hawai'i Non-Refundable Tax Credit as provided in this Section 5 (Tax Credit Pass Through);
- (iv) Upon receipt of any funds for the Hawai'i Non-Refundable Tax Credit, an officer of Seller or an Affiliate of Seller, if applicable, will deliver a notice to Company certifying (A) the amount of funds received, (B) and the amount of payment that will be made to Company, net of federal tax and any documented and reasonable financial, legal, administrative, and other costs required to claim, monetize and transfer such funds to Seller, as

supported by the officer's certificate as to the amount of such costs and the reasonableness thereof;

- (d) Seller shall use commercially reasonable efforts to apply for and obtain the maximum reasonably available Hawai'i Refundable and/or Non-Refundable Tax Credit as provided in this Section 5 (Tax Credit Pass Through). If Seller fails to apply for and to use commercially reasonable efforts to obtain such Hawai'i Renewable Energy Tax Credit as described above, then Company shall be entitled to liquidated damages in an amount equal **[\$150,000 per MW of Contract Capacity]**. Seller and Company agree and acknowledge that (i) the failure to use commercially reasonable efforts as provided in the preceding sentence would result in damages to Company in the form of reduction or loss of a benefit for Company's customers that would be difficult or impossible to calculate with certainty and (ii) **[Note - insert amount that equals \$150,000 per MW of Contract Capacity]** is an appropriate approximation of such damages. Company's right to collect liquidated damages as described in this Section 5(d) shall constitute Company's exclusive remedy and fulfillment of all Seller's liability with respect to its obligations to maximize the amount of Hawai'i Renewable Energy Tax Credit. Such liquidated damages shall be provided to Company in the form of a lump sum payment by Seller or as an energy price credit against any amounts due by Company to Seller for energy purchases under this Agreement, as Company reasonably determines.
- (e) If, prior to the application in Section 5(b) or filing in Section 5(c) of this Attachment J (Company Payments for Energy, Dispatchability and Availability of BESS), as applicable, a change in tax law occurs to introduce a Hawai'i Production Tax Credit or an alternative renewable tax credit, Seller will use commercially reasonable efforts to determine which tax strategy is likely to result in the larger Net Amount (based on net present value for tax credits earned over time) of usable tax credits. If, based on such efforts, Seller determines that either Section 5(b) or Section 5(c) would result in a larger Net Amount of usable tax credits, an officer of Seller will deliver a notice to Company certifying that Seller has reasonably determined that the selected form of Hawai'i Renewable Energy Tax

Credit is likely to result in the larger Net Amount (based on net present value for tax credits earned over time) of usable tax credits and explaining the rationale for such determination. If, however, Seller reasonably determines that such Hawai'i Production Tax Credit is likely to result in the larger Net Amount (based on net present value for tax credits earned over time) of usable tax credits and that it reasonably can obtain such Hawai'i Production Tax Credit, Seller shall promptly notify Company in writing and explain the rationale for such determination, and Seller and Company shall negotiate in good faith and use commercially reasonable efforts to agree upon lump sum payments and/or credits or adjustments to the Contract Price and other terms of this Agreement as may be required to best benefit Company's customers with 100% of the Net Amount of such tax benefits and preserve the intended economic benefits to the Parties arising from this Agreement.

- (f) Company reserves the right to have Seller's application for the Hawai'i Renewable Energy Tax Credit in Section 5(b) or Section 5(c), or the Hawai'i Production Tax Credit or alternative tax credit under Section 5(e) of this Attachment J (Company Payments for Energy, Dispatchability and Availability of BESS) reviewed by an Independent Tax Expert to determine if such application is expected to maximize available tax credits to best benefit Company's customers, in which case, the provisions of this Section 5(f) shall apply. Company shall deliver to Seller a written notice (the "Nomination Notice") of: (i) the names of three persons qualified and willing to accept appointment as an Independent Tax Expert; (ii) a description provided by each nominee of his or her qualifications to serve as an Independent Tax Expert; (iii) a written undertaking by each nominee to review Seller's tax credit strategy and application, and (iv) each nominee's fee proposal. Seller and Company shall agree on a mutually acceptable person to serve as the Independent Tax Expert within ten (10) Business Days of Seller's receipt of Company's written notice. If the Parties fail to agree upon a mutually acceptable Independent Tax Expert within the aforesaid ten Business Day period, such disagreement shall be resolved pursuant to Section 3(g) of this Attachment J (Company Payments for Energy, Dispatchability and Availability of BESS). Seller shall pay the fees and expenses of the Independent Tax Expert.

- (g) Any dispute arising under this Attachment J (Company Payments for Energy, Dispatchability and Availability of BESS) shall constitute a "Dispute" within the meaning of Article 28 (Dispute Resolution) of this Agreement and shall be resolved as provided in said Article 28 (Dispute Resolution).

- (h) For purposes of this Attachment J (Company Payments for Energy, Dispatchability and Availability of BESS), an Affiliate of Seller is a company that directly or indirectly controls, is controlled by, or is under common control with Seller, and Seller may perform its obligations under this Attachment J (Company Payments for Energy, Dispatchability and Availability of BESS) directly or through one or more Affiliates.

**[ATTACHMENT K WILL BE REVISED TO REFLECT
THE RESULTS OF IRS]**

ATTACHMENT K
GUARANTEED PROJECT MILESTONES

[For Developer Interconnection Build]

Guaranteed Project Milestone Date	Description of Each Guaranteed Project Milestone
[SPECIFY DATE CERTAIN]	<u>Construction Financing Milestone</u> : Provide Company with documentation reasonably satisfactory to Company evidencing (i) the closing on financing for the Facility including ability to draw on funds by [insert same date certain as in left column] or (ii) the financial capability to construct the Facility (" <u>Construction Financing Closing Milestone</u> ").
[SPECIFY DATE CERTAIN]	<u>Permit Application Filing Milestone</u> : Provide Company with documentation reasonably satisfactory to Company evidencing the filing by or on behalf of Seller of the following applications for Governmental Approvals required for the ownership, construction, operation and maintenance of the Facility: County Plan Approval
[SPECIFY DATE CERTAIN]	<u>Guaranteed Commercial Operations Date</u> .

**[ATTACHMENT K WILL BE REVISED TO REFLECT
THE RESULTS OF IRS]**

ATTACHMENT K-1
SELLER'S CONDITIONS PRECEDENT AND COMPANY MILESTONES

[For Developer Interconnection Build]

Seller's Conditions Precedent Date	Description of Each of Seller's Conditions Precedent
	Seller shall make payment to Company of the amount required under <u>Section 3(b)(ii) of Attachment G</u> (Company-Owned Interconnection Facilities)
	Seller shall provide Company a right of entry for the Company-Owned Interconnection Facilities site(s).
	Seller shall make payment to Company of the amount required under <u>Section 3(b)(iii) of Attachment G</u> (Company-Owned Interconnection Facilities)
	Seller's engineering, procurement and construction (" <u>EPC</u> ") contractor shall obtain grading permit.
	Seller's EPC contractor shall obtain and provide Company all permits (other than any required occupancy permits, if applicable), licenses, easements and approvals to construct the Company-Owned Interconnection Facilities, including the building permit.
No later than three (3) months prior to the commencement of the Acceptance Test	Seller shall provide station service power, if applicable, as required by Company.

<p>No later than three (3) months prior to the commencement of the Acceptance Test</p>	<p>Seller or Seller's EPC contractor shall have Hawaiian Telcom Backup (or equivalent) installed which shall consist of a 1.5 Mbps Routed Network Services circuit for backup SCADA communications from Company's Substation at Seller's Facility to Company's EMS located at the Company's control center.</p>
	<p>Seller's EPC contractor shall complete installation of physical bus and structures within Company's substation up to the demark point as necessary to interconnect.</p>
<p>[specify date] ("Test Ready Deadline")</p>	<p>Seller's EPC contractor shall complete construction of the Seller-Owned Interconnection Facilities, the Seller shall have satisfied the conditions precedent to the conduct of the Acceptance Test set forth in <u>Section 2 (f) (ii) of Attachment G</u> (Company-Owned Interconnection Facilities) and Seller is otherwise ready to conduct the Acceptance Test.</p>
	<p>Seller shall close grading permit, unless Seller provides documentation establishing, to Company's reasonable satisfaction, that closing the grading permit is not required by the relevant Governmental Authority prior to energization, testing and use of the Facility.</p>

COMPANY MILESTONES

If Seller satisfies the foregoing Seller's Conditions Precedent, the following Company Milestones shall apply:

Company Milestone Date	Description of Each Company Milestone
[] Business Days following the Test Ready Deadline	Company shall, subject to Seller's continued satisfaction of the requirements set forth in <u>Section 2 (f) (ii)</u> and <u>Section 2 (f) (iii)</u> of <u>Attachment G</u> (Company-Owned Interconnection Facilities), commence Acceptance Testing.
	Energization of Company-Owned Interconnection Facilities, provision of back-feed power to support commissioning.

**[ATTACHMENT L WILL BE REVISED TO REFLECT
THE RESULTS OF IRS]**

ATTACHMENT L
REPORTING MILESTONES

[For Developer Interconnection Build]

Reporting Milestone Date	Description of Each Reporting Milestone
[Date]	Seller shall provide Company with a redacted copy of the executed Facility equipment, engineering, procurement and construction (" <u>EPC</u> ") or other general contractor agreements. Under no circumstances shall redactions conceal information that is necessary for Company to verify its rights under the Agreement.
[Date]	Seller shall provide Company with redacted copies of executed purchase orders/contracts for the delivery of Facility inverters.
[Date]	Building Permit: Seller or Seller's EPC contractor shall obtain building permit.
[Date]	Construction Start Date (defined as the start of civil work on Site).
[Date]	Seller shall have laid the foundation for all Facility buildings, generating facilities and step-up transformer facilities.
[Date]	All inverters for the Facility shall have been installed at the Site.
[Date]	The step-up transformer shall have been installed at the Site.

ATTACHMENT M
FORM OF LETTER OF CREDIT

Page 1 of 2

[Bank Letterhead]

[Date]

Beneficiary: Hawai'i Electric Light Company, Inc.

[Address]

[Bank's Name]

[Bank's Address]

Re: **[Irrevocable Standby Letter of Credit Number]**

Ladies and Gentlemen:

We hereby establish, in your favor, our irrevocable standby Letter of Credit Number _____ (this "Letter of Credit") for the account of **[Applicant's Name]** and **[Applicant's Address]** in the initial amount of \$_____ **[dollar value]** and authorize you, Hawai'i Electric Light Company, Inc. ("Beneficiary"), to draw at sight on **[Bank's Name]**.

Subject to the terms and conditions hereof, this Letter of Credit secures **[Project Entity Name]**'s certain obligations to Beneficiary under the Power Purchase Agreement dated as of _____ between **[Project Entity Name]** and Beneficiary.

This Letter of Credit is issued with respect to the following obligations:_____.

This Letter of Credit may be drawn upon under the terms and conditions set forth herein, including any documentation that must be delivered with any drawing request.

Partial draws of this Letter of Credit are permitted. This Letter of Credit is not transferable. Drafts on us at sight shall be accompanied by a Beneficiary's signed statement signed by a representative of Beneficiary as follows:

The undersigned hereby certifies that (i) I am duly authorized to execute this document on behalf of Hawai'i Electric Light Company, Inc. and [(ii) the

amount of the draft accompanying this certification is due and owing to Hawai'i Electric Light Company, Inc. under the terms of the Power Purchase Agreement dated as of _____, between _____, and Hawai'i Electric Light Company, Inc.][(ii) the Letter of Credit will expire in less than thirty (30) days, it has not been replaced or extended and collateral is still required under Section _____ of the Power Purchase Agreement*].

Such drafts must bear the clause "Drawn under **[Bank's Name and Letter of Credit Number _____ and date of Letter of Credit.]**"

All demands for payment shall be made by presentation of originals or copies of documents, or by facsimile transmission of documents to **[Bank Fax Number]** or other such number as specified from time to time by the bank. If presentation is made by facsimile transmission, you may contact us at **[Bank Phone Number]** to confirm our receipt of the transmission. Your failure to seek such a telephone confirmation does not affect our obligation to honor such a presentation. If presented by facsimile, original documents are not required.

This letter of credit shall expire one year from the date hereof. Notwithstanding the foregoing, however, this letter of credit shall be automatically extended (without amendment of any other term and without the need for any action on the part of the undersigned or Beneficiary) for one year from the initial expiration date and each future expiration date unless we notify you and Applicant in writing at least thirty (30) days prior to any such expiration date that this letter of credit will not be so extended. Any such notice shall be delivered by registered or certified mail, or by FedEx, both to:

Beneficiary at:

and to

* For draw relating to lapse of Letter of Credit while credit support is still required pursuant to the Power Purchase Agreement.

And to Applicant at:

We hereby agree with drawers that drafts and documents as specified above will be duly honored upon presentation to **[Bank's Name]** and **[Bank's Address]** if presented on or before the then-current expiration date hereof.

Payment of any amount under this Letter of Credit by **[Bank]** shall be made as the Beneficiary shall instruct on the next Business Day after the date the **[Bank]** receives all documentation required hereunder, in immediately available funds on such date. As used in this Letter of Credit, the term "Business Day" shall mean any day other than a Saturday or Sunday or any other day on which banks in the State of **[Note - insert State of bank's location]** are authorized or required by law to be closed.

Unless otherwise expressly stated herein, this irrevocable standby letter of credit is issued subject to the rules of the International Standby Practices, International Chamber of Commerce publication no. 590 ("ISP98").

[Bank's Name]:

By: _____
[Authorized Signature]

ATTACHMENT N
ACCEPTANCE TEST GENERAL CRITERIA

**[THIS ATTACHMENT WILL NEED TO BE MODIFIED
BASED ON THE RESULTS OF THE IRS]**

Upon final completion of Company review of the Facility's drawings, final test criteria and procedures shall be agreed upon by Company and Seller no later than thirty (30) Days prior to conducting the Acceptance Test in accordance with the Agreement. The Acceptance Test shall include, but not be limited to, the following:

1. Interconnection.
 - (A) A visual inspection of all Interconnection equipment and verification of as-built drawings.
 - (B) Phase rotation testing to verify proper phase connections.
 - (C) Based on manufacturer's specification, test the local operation of the Facility's generator breaker(s) and inter-tie breaker(s), and other breaker(s) which connect the Facility equipment to Company System - must open and close locally using the local controls remotely from Company's EMS. Test and ensure that the status shown on the EMS is the same as the actual physical status in the field.
 - (D) Relay test engineers to connect equipment and simulate certain inputs to test and ensure that the protection schemes such as any under/over frequency and under/over voltage protection or the Direct Transfer Trip operate as designed. (For example, a fault condition may be simulated to confirm that the breaker opens to sufficiently clear the fault. Additional scenarios may be tested and would be outlined in the final test criteria and procedures.) Seller to also test the synchronizing mechanisms to which the Facility would be synchronizing and closing into the Company System to ensure correct operation. Other relaying also to be tested as specified in the protection review of the IRS and on the single line diagram, Attachment E (Single-Line Drawing and Interface Block Diagram) for the Facility.
 - (E) All 69 kV breaker disconnects and other high voltage switches will be inspected to ensure they are properly aligned and operated manually or automatically (if designed).
 - (F) Step-Up Transformer Enclosure(s) inspections - The Step-Up Transformer Enclosure(s) may be inspected to

test and ensure that the equipment that Seller has installed is installed and operating correctly based upon agreed to design. Wiring may be field verified on a sample basis against the wiring diagrams to ensure that the installed equipment is wired properly. The grounding mat at the Step-Up Transformer Enclosure(s) may be tested to make sure there is adequate grounding of equipment.

- (G) Communication testing - Communication System testing to occur to ensure correct operation. Detailed scope of testing will be agreed by Company and Seller to reflect installed systems and communication paths that tie the Facility to Company's communications system.
- (H) Various contingency scenarios to be tested to ensure adequate operation, including testing contingencies such as loss of communications, and fault simulations to ensure that the Facility's 69 kV breakers, if any, open as they are designed to open. (Back up relay testing)
- (I) Metering section inspection; verification of metering PTs, CTs, and cabinet and the installation of the two Company meters.

2. Telephone Communication.

- (A) Test to confirm Company has a direct line to the Facility control room at all times and that it is programmed correctly.
- (B) Test to confirm that the Facility operators can sufficiently reach Company System Operator.
- (C) Verification of dial-up telephone connection for 69 kV metering cabinet.

3. Drawings, Documentation and Equipment Warranties.

The items below are required components of the Acceptance Test and must be satisfied for successful completion of this Test.

- (A) Electronic and three (3) hard copies of all Switchyard construction drawings, specifications, calibrations, and settings including as-built drawings.

- (B) Equipment operating and maintenance manuals, spare parts lists, commissioning notes, as-built equipment settings, and other information related to the switchyard equipment.
- (C) Contractor construction warranties and equipment warranties.
- (D) Phase rotation testing to verify proper phase connections.
- (E) Switching Station inspections - The Switching Station may be inspected to test and ensure that the equipment that Seller has installed is installed and operating correctly based upon agreed-to design. Wiring may be field verified on a sample basis against the wiring diagrams to ensure that the installed equipment is wired properly. The grounding mat at the Switching Station may be tested to make sure there is adequate grounding of equipment.
- (F) If agreed by the Parties in writing, some requirements may be postponed to the Control Systems Acceptance Test.

ATTACHMENT O
CONTROL SYSTEM ACCEPTANCE TEST CRITERIA

**[THIS ATTACHMENT WILL NEED TO BE MODIFIED BASED ON THE RESULTS OF
THE IRS]**

- a. The Acceptance Test for the Facility will be conducted, following installation of the Facility. The Acceptance Test procedures will be in accordance with criteria set forth herein. The Acceptance Test shall be performed in accordance with Good Engineering and Operating Practices and demonstrate to Company's satisfaction that the Facility and the interconnection portion of the Facility, including Company-Owned Interconnection Facilities, have met the provisions of Article 8 (Company Dispatch) and Section 3 (Performance Standards) of Attachment B (Facility Owned by Seller).
- b. Acceptance Test procedures will be developed by Company for the Seller's review at least sixty (60) Days in advance of performing the tests based on the date provided by Company.
- c. The procedures will include, but not be limited to, demonstration of the functional requirements of the Facility defined in Article 8 (Company Dispatch) and Section 3 (Performance Standards) of Attachment B (Facility Owned by Seller) such as, but not limited to:
 - i. Interconnection equipment and communications to support remote monitoring of the Facility and control of Facility breakers
 - ii. Droop characteristic and change of frequency control / response modes (if applicable)
 - iii. Real power delivery under remote Company Dispatch, Active Power Dispatch. For facilities with directly controlled storage, the storage will be operated to perform at least two full charging/discharging cycles.
 - iv. Accurate provision of limits for Minimum and Maximum Dispatch (Power Possible, Minimum load capability)
 - v. Ramp rates for controlled actions
 - vi. Control of Facility breakers

- vii. Voltage regulation
- vii. Grid forming and Black start (if applicable)
- viii. BESS Capacity Test and demonstration of the round trip efficiency of the BESS, each as described in Attachment W (Capacity Tests)
- d. Testing of primary and redundant communications between Company System Operator and Facility Operator
- e. The actual dynamic response of the Facility equipment will be confirmed to allow Company transient stability model to reflect the as-left conditions of the unit. During the commissioning the following will be required:
 - i. A final review by Company engineers of the equipment installed to control the operation and protect the plant will be needed upon installation and prior to the start of commercial operation.
 - ii. The review will include off-line tuning and testing results of the excitation and governor control and/or control system and the IEEE block diagram utilized for the PSS/E dynamics program.
 - iii. During the commissioning of the actual Facility, equipment system testing will be conducted to ensure that similar, well damped, expected responses will be produced by the facility. The as-left parameters obtained from real and reactive local response tuning will be determined for use in the Company planning model. The Seller will provide an estimate of the earliest date for the Acceptance Test at least ninety (90) Days before the date.
- f. The Acceptance Test procedures for the Facility will be mutually agreed upon between Seller and Company prior to conducting the test.
- g. When the Facility is ready for the Acceptance Test, Seller shall notify Company at least seven (7) Days prior to the test and shall coordinate with Company. Seller shall perform and Company shall monitor such test no earlier than seven (7) Days from Company's receipt of such notice.

- h. The Control Acceptance Test is to be successfully completed prior to the Commercial Operation Date.

Examples of the type of tests conducted to meet the aforementioned objectives may include, but are not limited to the following:

On-site Tests:

1. SCADA Test to verify the status and analog telemetry, and if the remote controls between the Company's EMS and the Facility are working properly end-to-end.
2. Dispatch Test to verify if the Facility's active power limit controls and the Active Power Control Interface with the Company's EMS are working properly. The Test is generally conducted by setting different active power setpoints and limits and observing the proper dispatch at the appropriate ramp rate limiting of the Facility's real power output.
3. Control Test for Voltage Regulation to verify the Facility can properly perform automatic voltage regulation as defined in this Agreement. Test is generally conducted by making small adjustments of the voltage setpoint and verifying by observation that the Facility regulates the voltage at the point of regulation to the setpoint by delivering/receiving reactive power to/from the Company System to maintain the applicable setpoint according to the reactive power control and the reactive amount requirements of Sections 3(a) (Reactive Power Control) and Section 3(b) (Reactive Power Characteristics) of Attachment B (Facility Owned by Seller) to this Agreement.
4. Frequency Response Test to verify the Facility provides a frequency droop response as defined in this Agreement. Test is generally conducted by making adjustments of the frequency reference setting and verifying by observation that the Facility responds per droop and deadband settings, and appropriately modifies the Company issued Dispatch Setpoint. If different modes of frequency response are provided, each mode is tested (i.e.; isochronous, fast frequency response, active power droop response).
5. Loss-of-Communication Test to verify the Facility will properly shutdown upon the failure of the direct-transfer-trip communication system. Test is generally conducted by simulating a communications failure and observing the proper shutdown of the Facility. [If DTT required for the Project]

6. Round trip efficiency test, as described in Attachment W (Capacity Tests) to verify that the round trip efficiency of the BESS is not less than [_____] percent ([_____]%).
[DRAFTING NOTE: The round trip efficiency percentage will be taken from Seller's response to the RFP.]
7. BESS Capacity Test to verify the BESS Capacity Ratio.

Monitoring Test:

- a) The monitoring test requires the Facility to operate as it would in normal operations.
- b) To ensure useful and valid test data is collected for variable facilities, the monitoring test shall end when one of the following criteria is met:
 - A. For variable energy resources, Facility's gross power production is greater than 85% of its Allowed Capacity, for at least four (4) hours in any continuous 24-hour CSAT period.
 - B. For solar facilities, the recorded renewable energy resource at the Facility is above 600 W/m² for at least eight (8) hours in any continuous 48-hour CSAT period.
 - C. For wind facilities, the recorded wind speed is sufficient for turbines to operate for at least 8 hours in any continuous 48-hour CSAT period.
 - D. 14 continuous Days from the start of the CSAT.
- c) At the end of the test, an evaluation period is selected based on the criteria that triggered the end of the test.
- d) The performance of the Facility during the period of the successfully completed monitoring test is evaluated for, e.g., voltage regulation, frequency response, dispatch control, operating limits and ramp rate performance, to verify the performance meets the requirements of this Agreement according to the criteria set forth in the testing procedures. Certain requirements, such as disturbance ride-through requirements, cannot be adequately tested without actual grid disturbances. These requirements will be confirmed following a grid event based on operational data, which may be after the completion of the Acceptance Test. The Parties understand and agree that a successful completion of the test does not constitute a waiver of any of the performance standards of Seller, all of which are hereby reserved, and shall not alleviate Seller from any of its obligations under the Agreement, in particular, as required in Article 8 (Company Dispatch) and the Performance Standards

in Section 3 (Performance Standards) of Attachment B
(Facility Owned by Seller).

ATTACHMENT P
SALE OF FACILITY BY SELLER

1. Company's Right of First Negotiation Prior to End of the Term.
 - (a) Right of First Negotiation. Commencing as of the Commercial Operations Date, should Seller desire to sell, transfer or dispose of its right, title, or interest in the Facility, in whole or in part, including a Change in Control (as defined below), then, other than through an "Exempt Sale" (as defined below):
 - (i) Seller shall first offer to sell such interest to Company by providing Company with written notice of the same (the "Offer Notice"), which notice shall identify the proposed purchase price for such interest (including a description of any consideration other than cash that will be accepted) (the "Offer Price") and any other material terms of the intended transaction, and Company may, but shall not be obligated to, purchase such interest at the Offer Price and upon the other material terms and conditions specified in the Offer Notice, and in accordance with the terms and conditions of this Attachment P (Sale of Facility by Seller). Seller shall provide to Company as part of the Offer Notice, information in its possession regarding the Facility to allow Company to conduct due diligence on the potential purchase, including, but not limited to information on the operational status of the Facility and its components, and the amount of debt or other material Seller obligations remaining with respect to the Facility (the Offer Notice and due diligence information on the Facility are collectively referred to as, the "Offer Materials"). Within five (5) Days of Company's receipt of the Offer Materials, if Company believes the due diligence information is incomplete, Company shall specify in writing the additional information Company requires to conduct its due diligence. The date on which Company receives the Offer Materials from Seller is referred to hereinafter as the "Offer Date."
 - (ii) If Company desires to purchase such interest, Company shall indicate so by delivering to Seller a binding, written offer to purchase such interest at

the Offer Price and on the terms and conditions specified in the Offer Notice within thirty (30) Days of the Offer Date (an "Acceptance Notice"). In the event Company timely delivers an Acceptance Notice, Seller shall sell and transfer to Company the interest substantially on the terms and conditions contained in the Offer Notice consistent with this Attachment P (Sale of Facility by Seller) and in accordance with definitive documentation to be entered into between Seller and Company. The Parties shall have sixty (60) Days from the Company's Acceptance Notice, or such other extended timeframe as agreed to by the Parties in writing, to negotiate in good faith, the terms and conditions of a purchase and sale agreement. The period beginning with the Offer Date and ending with such sixty (60) Day period (as may be extended as aforesaid) is referred to as the "Right of First Negotiation Period".

- (iii) Seller shall not solicit any offers for the sale of such interest to any other party during the Right of First Negotiation Period unless, during that period, Company provides Seller with written notice that Company no longer desires to purchase such interest, whereupon negotiations shall terminate.
- (iv) In the event that (A) Company fails to timely deliver an Acceptance Notice, (B) Company delivers a notice to Seller that it no longer desires to purchase the interest, or (C) the Parties are not able to execute a purchase and sale agreement within the 60-Day period set forth in Section 1(a)(ii) of this Attachment P (Sale of Facility by Seller), Seller may for a period of two hundred seventy (270) Days following the event specified in subsection (A), (B) or (C) above, commence solicitation of offers and negotiations from and with other parties for the sale of such interest. If the interest is not transferred to a purchaser or purchasers for any reason within the two hundred seventy (270) Day period, the interest may only be transferred by again complying with the procedures set forth in this Section 1(a) (Right of First Negotiation) of Attachment P (Sale of Facility by Seller); provided, however, if Seller and the

prospective purchaser have entered into definitive agreement(s) for the sale of the interest that was reasonably expected to close within such two hundred seventy (270) Day period and such agreement(s) remain in full force and effect between Seller and such prospective purchaser and are subject to conditions precedent that are expected to be satisfied within a reasonable period, the two hundred seventy (270) Day period shall be extended as to such agreement(s) and such prospective purchaser for up to one hundred eighty (180) additional Days or, if sooner, until such date that such agreement(s) have been terminated, cancelled or otherwise become no longer in full force and effect.

(v) After expiration of the Right of First Negotiation Period, Company will not be precluded from providing offers or proposals to Seller along with other prospective purchasers in accordance with any offer or bid procedures established by Seller in its discretion.

(b) Change in Ownership Interests and Control of Seller. Commencing as of the Commercial Operations Date, the Right of First Negotiation shall also be triggered by a transfer or sale of an ownership interest in Seller (whether in a single transaction or a series of related or unrelated transactions) following which **[Note - insert parent entity]** or an entity controlled by **[parent entity]** is no longer a direct or indirect owner of at least fifty-one percent (51%) of the equity interest or voting control of Seller (excluding any equity interest or voting control of Seller held by a tax equity investor or for Financing Purposes (as defined below)) (such transfer of ownership interest and change in control collectively referred to as a "Change in Control"); provided, however that a transfer or sale whereby **[parent entity]** retains the possession, directly or indirectly, or the power to direct or cause the direction of the management and policies of Seller, whether through ownership, by contract, or otherwise, shall not be deemed a Change in Control.

(c) Exempt Sales. Exempt Sales shall not trigger a Right of First Negotiation and shall not require the consent of Company. As used herein, "Exempt Sales" means: (i) a

change in ownership of the Facility or equity interests in Seller resulting from the direct or indirect transfer or assignment by or of Seller in connection with financing or refinancing of the Facility ("Financing Purposes"), including, without limitation, any exercise of rights or remedies (including foreclosure) with respect to Seller's right, title, or interest in the Facility or equity interests in Seller undertaken by any financing party in accordance with applicable financing documents, and including, without limitation, (x) a sale and leaseback of the Facility, (y) an inverted lease, (z) a sale or transfer of equity in Seller to facilitate a tax credit financing (including any partnership "flip" transaction), (ii) a disposition of equipment in the ordinary course of operating and maintaining the Facility, (iii) a sale that does not result in a Change in Control, and (iv) a sale or transfer of any interest in Seller or the Facility to one or more companies directly or indirectly controlling, controlled by or under common control with Seller.

- (d) Seller's Right to Transfer. The provisions of this Section 1(d) (Seller's Right to Transfer) shall apply (i) from the Execution Date through the Commercial Operations Date and (ii) from the Commercial Operations Date in the event that Company does not consummate a purchase pursuant to its exercise of the Right of First Negotiation in accordance with the terms and conditions of this Attachment P (Sale of Facility by Seller). In such circumstances, Seller shall, subject to the prior written consent of Company, which consent shall not be unreasonably withheld, conditioned or delayed, have the right to transfer or sell the Facility to any person or entity which proposes to acquire the Facility with the intent to continue the operation of the Facility in accordance with the provisions of this Agreement pursuant to an assignment of this Agreement. Company shall consent to the assignment of this Agreement to such prospective purchaser upon receiving documentation from Seller establishing, to Company's reasonable satisfaction, that the assignee (i) has a tangible net worth of \$100,000,000 or a credit rating of "BBB-" or better and has the ability to perform its financial obligations hereunder (or provides a guaranty from an entity that meets this description) in a manner consistent with the terms and conditions of this Agreement; and (ii) has experience in the ownership and

at least five (5) years of experience in the operation (or contracts with an entity that has at least five (5) years of experience in the operation) of power generation and BESS facilities; provided, however, that Company shall be deemed to have consented to the assignment if, within ten (10) Business Days of receiving from Seller the documentation establishing that the assignee meets all the foregoing criteria, Company does not either (y) deliver the required consent to Seller, or (z) notify Seller which of the foregoing criteria is not established by such documentation. Notwithstanding the foregoing, Company consent shall not be required for any Exempt Sale.

- (e) Purchase and Sale Agreement and PUC Approval. In the event that Company exercises its Right of First Negotiation under Section 1(a) (Right of First Negotiation) of this Attachment P (Sale of Facility by Seller) and the Parties conclude a purchase and sale agreement, such agreement shall contain, at a minimum, the terms set forth in Section 4 (Purchase and Sale Agreement) of this Attachment P (Sale of Facility by Seller), and such agreement shall be subject to PUC Approval as provided in Section 5 (PUC Approval) of this Attachment P (Sale of Facility by Seller).
- (f) Right of First Refusal. In the event the Parties fail to agree upon a sale of the Facility or an interest in the Facility to Company prior to the expiration of the Right of First Negotiation Period, the provisions of this Section 1(f) (Right of First Refusal) of this Attachment P (Sale of Facility by Seller) shall apply if (i) Seller thereafter offers to sell the Facility to a third party for less than (as applicable) the final amount Company had offered to purchase the Facility or (ii) an ownership interest in the Facility that would result in a Change in Control is offered for sale to a third party that is less than the proportionate share of (as applicable) the final amount Company had offered to purchase the Facility. (By way of example, if the final amount offered by Company to purchase the Facility was \$100, and the ownership interest being offered for sale is 75%, the "proportionate share" is \$75, such that an offer to sell such ownership interest for less than \$75 would trigger this Section 1(f) (Right of First Refusal) of this Attachment P (Sale of Facility by Seller).) Seller shall notify Company in writing of an offer that

triggers this Section 1(f) (Right of First Refusal) of this Attachment P (Sale of Facility by Seller) and Company shall have the right to purchase the Facility for the amount of such offer on similar terms and conditions consistent with this Attachment P (Sale of Facility by Seller) and subject to PUC Approval; provided, that Company shall have one (1) month in which to notify Seller of its intent to exercise this right. If the offer of which Seller notifies Company as aforesaid is an offer to sell the Facility, Company shall have the right to purchase the Facility for the amount of such offer on similar terms and conditions. If the offer of which Seller notifies Company as aforesaid is an offer to sell an ownership interest that could result in a Change in Control, Company shall have the right to purchase the Facility by a price that is proportionate to the amount at which such ownership interest was offered on the terms and conditions to be negotiated by the Parties on the basis of Section 4 (Purchase and Sale Agreement) of this Attachment P (Sale of Facility by Seller), and otherwise consistent with this Attachment P (Sale of Facility by Seller). (By way of example, if a 75% ownership Interest is being offered for sale at \$75, the proportionate amount at which Company shall have the right to purchase the Facility would be \$100.)

2. Company's Right of First Negotiation to Purchase at End of Term.

- (a) Option of Exclusive Negotiation Period. Company shall have the option of an exclusive negotiation period to negotiate a purchase of the Facility on the last Day of the Term, and all rights of Seller therein or relating thereto. Company shall indicate its preliminary interest in exercising the option for exclusive negotiation by delivering to Seller a notice of its preliminary interest not less than two (2) years prior to the last Day of the Term. If Company fails to deliver such notice by such date, Company's option shall terminate.
- (b) Negotiations. Once Company has given such notice of preliminary interest to Seller, for a period not to exceed three (3) months, Company shall have the exclusive right to negotiate in good faith with Seller,

the terms of a purchase and sale agreement pursuant to which Company may purchase the Facility, which purchase and sale agreement shall include, without limitation, the terms set forth in Section 4 (Purchase and Sale Agreement) of this Attachment P (Sale of Facility by Seller) and a price equal to the Offer Price as presented by Seller in accordance with the procedures identified in Section 1(a)(i) through (v) of this Attachment P (Sale of Facility by Seller). The Parties may agree in writing to extend this period for negotiations. (Such period, as extended as aforesaid, is referred to herein as the "Exclusive Negotiation Period.") Seller shall not solicit any offers or negotiate the terms for the sale of the Facility with any other entity during the Exclusive Negotiation Period, unless, during the Exclusive Negotiation Period, Company gives written notice that such negotiations are terminated.

- (c) Purchase and Sale Agreement and PUC Approval. In the event that Company exercises its right of exclusive negotiation under Section 2(a) (Option of Exclusive Negotiation Period) of this Attachment P (Sale of Facility by Seller) and the Parties conclude a purchase and sale agreement pursuant to Section 2(b) (Negotiations) of this Attachment P (Sale of Facility by Seller), such agreement shall contain, at a minimum, the terms set forth in Section 4 (Purchase and Sale Agreement) of this Attachment P (Sale of Facility by Seller), and such agreement shall be subject to PUC Approval as provided in Section 5 (PUC Approval) of this Attachment P (Sale of Facility by Seller).
- (d) Right of First Refusal. In the event the Parties fail to agree upon a sale of the Facility to Company prior to the expiration of the Exclusive Negotiation Period provided in Section 2(b) (Negotiations) of this Attachment P (Sale of Facility by Seller), and Seller thereafter offers to sell the Facility to a third party for less than the final amount Company had offered to purchase the Facility, Seller shall notify Company in writing of such offer and Company shall have the right to purchase the Facility for the amount of such offer and on no less favorable terms and conditions consistent

with this Attachment P (Sale of Facility by Seller) and subject to PUC Approval; provided, however, that Company shall have one (1) month in which to notify Seller of its intent to exercise this right. The Right of First Refusal shall not apply to any offer to purchase the Facility received from a third party more than twelve (12) months after the end of the Term.

3. Procedure to Determine Fair Market Value of the Facility.

- (a) If the Parties have agreed to effectuate a sale of the Facility pursuant to Section 24.5 (Consolidation) and are unable to agree on the fair market value of the Facility, each of Company and Seller shall engage the services of an independent appraiser experienced in appraising power generation assets similar to the Facility to determine separately the fair market value of the Facility. Subject to the appraisers' execution and delivery to Seller of a suitable confidentiality agreement in form reasonably acceptable to Seller, Seller shall provide both appraisers full access to the books, records and other information related to the Facility required to conduct such appraisal. Company shall pay all reasonable fees and costs of both appraisers, subject to Section 3(c) of this Attachment P (Sale of Facility by Seller). Each of Company and Seller shall use reasonable efforts to cause its appraisal to be completed within two (2) months following the engagement of the independent appraisers. If for any reason (other than failure by Seller to provide full access to Company's appraiser) one of the appraisals is not completed within such two (2) month period, the results of the other, completed appraisal shall be deemed to be the Appraised Fair Market Value of the Facility. Each Party may provide to both appraisers (with copies to each other) a list of factors which the Parties suggest be taken into consideration when the appraisers generate their appraisals.
- (b) Company and Seller shall exchange the results of their respective appraisals when completed and, in connection therewith, the Parties and their appraisers shall confer in an attempt to agree upon the fair market value of the Facility.

- (c) If, within thirty (30) Days after completion of both appraisals, the Parties cannot agree on a fair market value for the Facility, within ten (10) Days thereafter, the first two appraisers shall by mutual consent choose a third independent appraiser. If the first two appraisers fail to agree upon a third appraiser, such appointment shall be made by DPR upon application of either Party. The Parties shall direct the third appraiser (i) to select one of the appraisals generated by the first two appraisers as the Appraised Fair Market Value of the Facility (without compromise, aka "baseball" arbitration), and (ii) to complete his or her work within one month following his or her retention. If the third appraiser selects the appraisal originally generated by Seller's appraiser, Company shall pay the fees and costs of the third appraiser. If the third appraiser selects the appraisal originally generated by Company's appraiser, Seller shall pay the fees and costs of the third appraiser and shall pay or reimburse Company for the costs of Seller's original appraiser.
- (d) The "Appraised Fair Market Value of the Facility" means the fair market value determined by appraisal pursuant to Section 3(a) or Section 3(c) of this Attachment P (Sale of Facility by Seller) as applicable.
4. Purchase and Sale Agreement. The purchase and sale agreement ("PSA") concluded by the Parties pursuant to this Attachment P (Sale of Facility by Seller) (as applicable) shall contain, among other provisions, the following:
- (a) Seller shall, as of the closing of the sale, convey title to the Facility consistent with the state of title in existence as of the date of execution of the PSA, including all rights of Seller in the Facility or relating thereto, free and clear of all liens, claims, encumbrances, or rights of others, except any Permitted Lien;
- (b) To the extent assignable or transferrable, Seller shall assign or transfer to Company all of Seller's interest in all Project Documents and Governmental Approvals that are then in effect and that are utilized for the operation or maintenance of the Facility;

- (c) Seller shall execute and deliver to Company such deeds, bills of sale, assignments and other documentation as Company may reasonably request to convey title to the Facility consistent with the state of title in existence as of the date of execution of the PSA, free from all liens, claims, encumbrances, or rights of others, except any Permitted Lien;
- (d) Seller shall cause all liens on the Facility for monies owed (including liens arising from Financing Documents), and any liens in favor of Seller's affiliates, to be released prior to closing on the sale of the Facility to Company;
- (e) Seller shall warrant, as of the date of the closing of the sale of the Facility to Company, title to the Facility consistent with the state of title in existence as of the date of execution of the PSA, is free and clear of all other liens, claims, encumbrances and rights of others, except any Permitted Lien;
- (f) Company shall have no liability for damages (including without limitation, any development and/or investment losses, liabilities or damages, and other liabilities to third parties) incurred by Seller on account of Company's purchase of the Facility, nor any other obligation to Seller except for the purchase price, and Seller shall indemnify Company against any such losses, liabilities or damages;
- (g) Company shall assume all of Seller's obligations with respect to the Facility accruing from and after the date of closing on the sale of the Facility to Company, including (i) to the extent assignable, all Permits held by, for, or related to the Facility, and (ii) all of Seller's agreements with respect to the Facility provided to and approved by Company at least thirty (30) Days prior to the date of closing on the sale of the Facility to Company, except for such agreements Company has elected to terminate, in which case any related termination expenses shall be, at Company's option, paid directly by Company and deducted from the purchase price;
- (h) Seller shall indemnify Company against all of Seller's obligations with respect to the Facility accruing through the date of closing the sale of the Facility to

Company, and Company shall indemnify Seller against all of Company's obligations with respect to the Facility accruing from and after the date of closing on the sale of the Facility to Company;

- (i) Unless otherwise agreed to by the Parties, Seller makes no representations or warranties with respect to the condition of the Facility, and Company shall purchase the Facility on an as-is basis;
- (j) Seller shall warrant that, except as disclosed to and approved by Company in writing at least thirty (30) Days prior to the date of closing on the sale of the Facility to Company, the Facility has been operated by Seller in conformity with all Laws;
- (k) Seller shall warrant that Seller provided full access to Company and each appraiser in connection with the procedure to determine fair market value provided in Section 3 (Procedure to Determine Fair Market Value of the Facility) of this Attachment P (Sale of Facility by Seller);
- (l) If applicable, Seller's lease of the Site from Company will terminate and Seller will relinquish all rights, privileges and obligations relating to such lease; and
- (m) Seller shall maintain the Facility in accordance with Good Engineering and Operating Practices between appraisal and the closing date.

As used in this Attachment P (Sale of Facility by Seller), "Permitted Lien" shall mean (i) any lien for taxes not yet due or delinquent or being contested in good faith by appropriate proceedings, (ii) any lien arising in the ordinary course of business by operation of applicable Laws with respect to a liability not yet due or delinquent or that is being contested in good faith, (iii) all matters that are disclosed (whether or not subsequently deleted or endorsed over) on any survey, in the title policies insuring any Land Rights or in any title commitments, title reports or other title materials, (iv) any matters that would be disclosed by a complete and correct survey of the Property, (v) zoning, planning, and other similar limitations and restrictions, and all rights of any Governmental Authority to regulate the Site and/or the Facility, (vi) all matters of record, (vii) any lien that is released on or prior to closing of the sale of the Facility to Company, (viii) statutory or common law liens

in favor of carriers, warehousemen, mechanics and materialmen, and statutory or common law liens to secure claims for labor, materials or supplies arising in the ordinary course of business which are not delinquent, and (ix) the matters agreed by the Parties, to the extent that such Permitted Liens are taken into account at arriving at the appraised value.

5. PUC Approval. Any purchase and sale agreement related to the Facility entered into by the Parties is subject to approval by the PUC and the Parties' respective obligations thereunder are conditioned upon receipt of such approval, except as specifically provided otherwise therein.

(a) Company shall submit the purchase and sale agreement to the PUC for approval within thirty (30) Days after execution by both Parties, but Company does not extend any assurances that PUC approval will be obtained. Seller will provide reasonable cooperation to expedite obtaining an approval order from the PUC, including providing information requested by the PUC and parties to the PUC proceeding in which approval is being sought. Seller understands that lack of cooperation may result in Company's inability to file an application with the PUC and/or failure to receive PUC approval. Unless otherwise agreed to in writing by the Parties, neither Company nor Seller shall seek reconsideration, appeal, or other administrative or judicial review of any unfavorable PUC order. The Parties agree that neither Party has control over whether or not a PUC approval order will be issued and each Party hereby assumes any and all risk arising from, or relating in any way to, the inability to obtain a satisfactory PUC order and hereby releases the other Party from any and all claims relating thereto.

(b) Seller shall seek participation without intervention in the PUC docket for approval of the purchase and sale agreement pursuant to applicable rules and orders of the PUC. The scope of Seller's participation shall be determined by the PUC. However, Seller expressly agrees to seek participation for the limited purpose and only to the extent necessary to assist the PUC in making an informed decision regarding the approval of the purchase and sale agreement. If the Seller chooses not to seek participation in the docket, then Seller expressly agrees and knowingly waives the right to claim, before

the PUC, in any court, arbitration or other proceeding, that the information submitted and the application requesting the PUC approval are insufficient to meet Company's burden of justifying that the terms of the purchase and sale agreement are just and reasonable and in the public interest, or otherwise deficient in any manner for purposes of supporting the PUC's approval of the purchase and sale agreement. Seller shall not seek in the docket and Company shall not disclose any confidential information to Seller that would provide Seller with an unfair business advantage or would otherwise harm the position of others with respect to their ability to compete on equal and fair terms.

- (c) In order to constitute an approval order from the PUC under this Section 5 (PUC Approval) of this Attachment P (Sale of Facility by Seller), the order must approve the purchase and sale agreement, Company's funding arrangements and Company's acquisition of the Facility, shall not contain any terms and conditions deemed to be unacceptable by Company, and be in a form deemed reasonable by Company in its sole, but non-arbitrary, discretion.
- (d) The Final Non-Appealable Order from the PUC must be obtained within six (6) months of the submission of the purchase and sale agreement to the PUC, or any extension of such period as agreed by the Parties in writing within ten (10) Days of the expiration of the six (6) month period; provided, however, that if the purchase and sale agreement governs a sale of the Facility executed pursuant to Section 24.5 (Consolidation) of this Agreement, the Final Non-Appealable Order must be obtained within twelve (12) months of the submission of the purchase and agreement to the PUC, or any extension of such period as agreed by the Parties in writing within ten (10) Days of the expiration of the twelve (12) month period. The term "Final Non-appealable Order from the PUC" means an Approval Order from the PUC (i) that is not subject to appeal to any Circuit Court of the State of Hawai'i, Intermediate Court of Appeals of the State of Hawai'i, or the Supreme Court of the State of Hawai'i, because the period permitted for such an appeal has passed without the filing of notice of such an appeal, or (ii) that was affirmed on appeal to any Circuit Court of the State of Hawai'i, Intermediate Court of Appeals of the State of Hawai'i, or the Supreme

Court of the State of Hawai'i, or was affirmed upon further appeal or appellate process, and that is not subject to further appeal, because the jurisdictional time permitted for such an appeal and/or further appellate process such as a motion for reconsideration or an application for writ of certiorari has passed without the filing of notice of such an appeal or the filing for further appellate process. Such Final Non-Appealable Order from the PUC shall constitute and be referred to as "PUC Approval" for purposes of this Attachment P (Sale of Facility by Seller).

- (e) If a Final Non-Appealable Order from the PUC has not been obtained prior to the deadline provided in Section 5(b) of this Attachment P (Sale of Facility by Seller), either Party may give written notice to the other Party that it does not wish to proceed further with a sale of the Facility to Company.
 - (f) If the Final Non-appealable Order from the PUC does not satisfy the conditions set forth in Section 5(a) of this Attachment P (Sale of Facility by Seller), either (i) the Parties may agree to renegotiate and submit a revised purchase and sale agreement to the PUC, or (ii) either Party may give written notice to the other Party that it does not wish to proceed further with a sale of the Facility to Company.
6. Make Whole Amount. For purposes of Section 24.5 (Consolidation), the "Make Whole Amount" shall be equal to the sum of the following: (a) Seller's book value (including depreciation on a twenty-five (25) year straight line basis) of all actual verifiable costs of studies, designs, engineering, and construction of the Facility and all Interconnection Facilities (including any Company-Owned Interconnection Facilities paid for by Seller), including cancellation charges and other costs of unwinding construction and demobilization if the determination is made prior to the Commercial Operation Date, (b) Seller's book value of all actual verifiable costs and expenses acquiring real estate rights for the Facility and Interconnection Facilities, (c) Seller's book value of all actual verifiable costs and expenses incurred in obtaining Governmental Approvals, (d) Seller's book value of all actual verifiable costs of financing the Facility and the Interconnection Facilities, including fees and expenses of bankers, consultants and counsel, and any discounts or premiums paid

in connection with any financing, (e) any actual verifiable costs of repaying any financing in connection with a sale, including prepayment penalties or premiums, make whole payments, minimum interest payments, breakage fees, payments on account of taxes, duties and other costs, and other costs of unwinding swaps or other hedges, (f) other breakage, make whole or indemnity payments arising as the result of Company's purchase of the Facility, (g) tax costs, including recapture of federal or state tax credits and payment of transfer taxes, and (h) interest on the foregoing amounts at annual rate equal to the Prime Rate plus two percent (2%) as in effect from time to time from the date incurred through the date of payment, with all such costs being demonstrated by Seller with support and verified by Company. The items described in clauses (e), (f) and (g) (and clause (h) to the extent applicable to clauses (e), (f) and/or (g)) are referred to as the "Financial Termination Costs".

ATTACHMENT Q
[RESERVED]

ATTACHMENT R
REQUIRED INSURANCE

(See also Article 18 (Insurance))

1. Worker's Compensation and Employers' Liability. This coverage shall include Worker's Compensation, Temporary Disability and other similar insurance required by applicable State or U.S. federal laws. If exposure exists, coverage required by the Longshore and Harbor Worker's Compensation Act (33 U.S.C. §688) shall be included. Employers' Liability coverage limits shall be no less than:

Bodily Injury by Accident - \$1,000,000 each Accident
Bodily Injury by Disease - \$1,000,000 each Employee
Bodily Injury by Disease - \$1,000,000 policy limit

2. General Liability Insurance.

- (i) This coverage shall include Commercial General Liability Insurance or the reasonable equivalent thereof, covering all operations by or on behalf of Seller. Such coverage shall provide insurance for bodily injury and property damage liability for the minimum limits of liability indicated below and shall include coverage for:

- (a) Premises, operations, and mobile equipment,
- (b) Products and completed operations,
- (c) Claims resulting from alleged damage to the environment and damage or injury caused by hazardous conditions or hazardous materials to the extent such coverage is appropriate and available at a commercially reasonable cost,
- (d) Blanket contractual liability,
- (e) Broad form property damage (including completed operations),
- (f) No exclusion for (XCU) explosion, collapse and underground hazard,
- (g) Personal injury liability, and
- (h) Failure to supply liability, which may be provided as a sublimit of \$1,000,000 per occurrence under

the general liability policy, on ISO endorsement CG 22 50 or equivalent, so long as such coverage is available on a commercially reasonable basis.

(ii) Limits of liability for Bodily Injury & Property Damage shall be:

\$10,000,000 combined single limit per occurrence and;
\$20,000,000 aggregate annually

(iii) Coverage limits may be satisfied using Umbrella and/or Excess Liability insurance policies.

3. Automobile Liability Insurance. This insurance shall include coverage for owned (if any), leased and non-owned automobiles. The minimum limits of liability shall be a combined single limit for bodily injury and property damage of Two Million Dollars (\$2,000,000) for each occurrence and in the aggregate annually. If exposure exists, the policy shall be endorsed to include Transportation Pollution Liability insurance, covering hazardous materials to be transported by Seller, as appropriate.
4. Builders All Risk Insurance. This insurance shall include but not be limited to coverage for wind including named windstorm, earthquake, flood, perils, property in transit (excluding ocean transit), off-site storage - property in temporary storage or assembly away from the project site, testing, covering all materials, equipment, machinery and supplies of any nature whatsoever, the property of the Seller or of others for which the Seller may have assumed responsibility, used or to be used in or incidental to the site preparation, demolition of existing structures, erection and/or fabrication and/or reconstruction and/or repair of the project insured, including temporary works (all scaffolding, formworks, fences, shoring, hoarding, false work and temporary buildings and all incidental to the project) from the start of construction through the earlier of the Commercial Operations Date or the effective date of the policy coverage set forth in Section 5 (All Risk Property/Comprehensive Mechanical and Electrical Breakdown Insurance (Upon Completion of Construction)) of this Attachment R (Required Insurance). The amount of coverage shall be purchased on a full replacement cost basis, except for earthquake, windstorm and flood perils which shall be provided as sublimits and aggregate limits supported by a Probable Maximum Loss (PML) study and/or Catastrophe (CAT) Modeling report, if such insurance amounts are appropriate

and available on commercially reasonable terms. The coverage shall be written on an "All Risks" completed value form and may allow for reasonable other sublimits for transit and for incidental offsite storage. Coverage shall be extended to include testing. Such policies shall be endorsed to require that the coverage afforded shall not be canceled (except for nonpayment of premiums) or reduced without at least thirty (30) Days' prior written notice to Seller and Company; provided, however, that such endorsement shall provide (i) that the insurer may not cancel the coverage for non-payment of premium without giving Seller and Company ten (10) Days' notice that Seller has failed to make timely payment thereof, and (ii) that, subject to the consent of the Facility Lender, Seller or Company shall thereupon have the right to pay such premium directly to the insurer.

5. All Risk Property/Comprehensive Mechanical and Electrical Breakdown Insurance (Upon Completion of Construction). This insurance shall provide All Risk Property Coverage (including the perils of wind including named windstorm, earthquake, and flood) and Comprehensive Mechanical and Electrical Breakdown Coverage against damage to the Facility. The amount of coverage shall be purchased on a full replacement cost basis (no coinsurance shall apply) except for earthquake, windstorm and flood perils which shall be provided as sublimits and aggregate limits supported by a Probable Maximum Loss (PML) study and/or Catastrophe (CAT) Modeling reports, if such insurance amounts are appropriate and available on commercially reasonable terms. Such coverage may allow for other reasonable sublimits. Such policies shall be endorsed to require that the coverage afforded shall not be canceled (except for nonpayment of premiums) or reduced without at least thirty (30) Days' prior written notice to Seller and Company; provided, however, that such endorsement shall provide (i) that the insurer may not cancel the coverage for non-payment of premium without giving Seller and Company ten (10) Days' notice that Seller has failed to make timely payment thereof, and (ii) that, subject to the consent of the Facility Lender, Seller or Company shall thereupon have the right to pay such premium directly to the insurer.
6. Business Interruption Insurance (Upon Completion of Construction). This insurance shall provide coverage for all of Seller's costs to the extent that they would not be eliminated or reduced by the failure of the Facility to operate for a period of at least twelve (12) months following

a covered physical damage loss deductible period or reasonable dollar deductible or waiting period.

7. [Reserved]
8. Ocean Transit. Seller shall take reasonable action to ensure that the risk of loss or damage to any material items of equipment which are subject to ocean transit is adequately protected against by the terms of delivery from contractors or suppliers of such equipment or Seller's own insurance coverage.

ATTACHMENT S
FORM OF MONTHLY PROGRESS REPORT

1. Instructions

Any capitalized terms used in this report which are not defined herein shall have the meaning ascribed to them in the Power Purchase Agreement for Renewable As-Available Energy by and between [_____] ("Seller"), and Hawai'i Electric Light Company, Inc., a Hawai'i corporation, dated _____, (the "Agreement").

In addition to the remedial action plan requirement set forth in Article 13 (Guaranteed Project Milestones Including Commercial Operations) of the Agreement, Seller shall review the status of each Construction Milestone of the construction schedule (the "Schedule") for the Facility and identify such matters referenced in clauses (i)-(v) below as known to Seller and which in Seller's reasonable judgment are expected to adversely affect the Schedule, and with respect to any such matters, shall state the actions which Seller intends to take to ensure that the Construction Milestones will be attained by their required dates. Such matters may include, but shall not be limited to:

(i) Any material matter or issue arising in connection with a Governmental Approval, or compliance therewith, with respect to which there is an actual or threatened dispute over the interpretation of a law, actual or threatened opposition to the granting of a necessary Governmental Approvals, any organized public opposition, any action or expenditure required for compliance or obtaining approval that Seller is unwilling to take or make, or in each case which could reasonably be expected to materially threaten or prevent financing of the Facility, attaining any Construction Milestone, or obtaining any contemplated agreements with other parties which are necessary for attaining any Construction Milestone or which otherwise reasonably could be expected to materially threaten Seller's ability to attain any Construction Milestone.

(ii) Any development or event in the financial markets or the independent power industry, any change in taxation or accounting standards or practices or in Seller's business or prospects which reasonably could be expected to materially threaten financing of the Facility, attainment of any Construction Milestone or materially threaten any contemplated agreements with other parties which are necessary for attaining

any Construction Milestone or could otherwise reasonably be expected to materially threaten Seller's ability to attain any Construction Milestone;

(iii) A change in, or discovery by Seller of, any legal or regulatory requirement which would reasonably be expected to materially threaten Seller's ability to attain any Construction Milestone;

(iv) Any material change in the Seller's schedule for initiating or completing any material aspect of the Facility;

(v) The status of any matter or issue identified as outstanding in any prior Monthly Progress Report and any material change in the Seller's proposed actions to remedy or overcome such matter or issue.

For the purpose of this report, "EPC Contractor" means the contractor responsible for engineering, procurement and construction of the Facility, including Seller if acting as contractor, and including all subcontractors.

2. Executive Summary

2.1 Major activities completed

Please provide a cumulative summary of the major activities completed for each of the following aspects of the Facility (provide details in subsequent sections of this report):

- 2.1.1 **[Insert Construction Milestones from Attachment K and Attachment L, if needed]**
- 2.1.2 Financing
- 2.1.3 Governmental Approvals for Development
- 2.1.4 Site Control
- 2.1.5 Land Rights for Company-Owned Interconnection Facilities
- 2.1.6 Design and Engineering
- 2.1.7 Major Equipment Procurement
- 2.1.8 Construction

- 2.1.9 Interconnection
- 2.1.10 Startup Testing and Commissioning

2.2. Major activities recently performed

Please provide a summary of the major activities performed for each of the following aspects of the Facility since the previous report (provide details in subsequent sections of this report):

- 2.2.1 [Insert Construction Milestones from Attachment K and Attachment L, if needed]**
- 2.2.2 Financing
- 2.2.3 Development Permits
- 2.2.4 Site Control
- 2.2.5 Land Rights for Company-Owned Interconnection Facilities
- 2.2.6 Design and Engineering
- 2.2.7 Major Equipment Procurement
- 2.2.8 Construction
- 2.2.9 Interconnection
- 2.2.10 Startup Testing and Commissioning

2.3 Major activities planned but not completed

Please provide a summary of the major activities that were planned to be performed since the previous report but not completed as scheduled, including the reasons for not completing the activities, for each of the following aspects of the Facility:

- 2.3.1 [Insert Construction Milestones from Attachment K and Attachment L, if needed]**
- 2.3.2 Financing
- 2.3.3 Governmental Approvals for Development

- 2.3.4 Site Control
- 2.3.5 Land Rights for Company-Owned Interconnection Facilities
- 2.3.6 Design and Engineering
- 2.3.7 Major Equipment procurement
- 2.3.8 Construction
- 2.3.9 Interconnection
- 2.3.10 Startup Testing and Commissioning

2.4 Major activities expected during the current month

Please provide a summary of the major activities to be performed during the current month for each of the following aspects of the Facility (provide details in subsequent sections of this report):

- 2.4.1 Construction Milestones
- 2.4.2 Financing
- 2.4.3 Governmental Approvals
- 2.4.4 Site Control
- 2.4.5 Land Rights for Company-Owned Interconnection Facilities
- 2.4.6 Design and Engineering
- 2.4.7 Major Equipment procurement
- 2.4.8 Construction
- 2.4.9 Interconnection
- 2.4.10 Startup Testing and Commissioning

3. Milestones

3.1 Milestone schedule

Please list all Construction Milestones specified in Attachment K and Attachment L and state the current status of each.

Construction Milestone	Milestone Date Specified in the Agreement	Status (e.g., on schedule, delayed due to [<i>specify reason</i>]; current expected completion date)
-------------------------------	--	--

3.2 Remedial Action Plan (if applicable)

Provide a detailed description of Seller's course of action and plan to achieve the missed Construction Milestones and all subsequent Construction Milestones by the Guaranteed Commercial Operation Date using the outline provided below.

- 3.2.1 Identify Missed Construction Milestone
- 3.2.2 Explain plans to achieve missed Construction Milestone
- 3.2.3 Explain plans to achieve subsequent Construction Milestones
- 3.2.4 Identify and discuss (a) delays in engineering schedule, equipment procurement, and construction and interconnection schedule and (b) plans to remedy delays as a result of the missed Construction Milestones

4. Financing

Please provide the schedule Seller intends to follow to obtain financing for the Facility. Include information about each stage of financing.

Activity (e.g., obtain \$xx for yy stage from zz)	Completion Date
	__/__/____ (expected / actual)
	__/__/____ (expected / actual)

5. Project Schedule

Please provide a copy of the current version of the overall Facility schedule (e.g., Work Breakdown Structure, Gantt chart, MS Project report, etc.). Include all major activities for Governmental Approvals for Development, design and engineering, procurement, construction, interconnection and testing.

6. Governmental Approvals

6.1 Environmental Impact Review

Please provide information about the primary environmental impact review for the Facility. Indicate whether dates are expected or actual.

Agency

Date of application/submission

__/__/____
 (expected /
 actual)

**Date application/submission deemed
 complete by agency**

__/__/____
 (expected /
 actual)

Date of initial study (if applicable)

__/__/____
 (expected /
 actual)

Process (e.g., Notice of Exemption,
 Negative Declaration, Mitigated
 Negative Declaration, Environmental
 Impact Report)

Date of Notice of Preparation

__/__/____
 (expected /
 actual)

Date of Draft ND/MND/EIR

__/__/____
 (expected /
 actual)

**Date Notice of Determination filed at
 OPR or County Clerk**

__/__/____
 (expected /
 actual)

Governmental Approvals

Please describe each of the Governmental Approvals to be obtained by Seller and the status of each:

Agency / Approval	Status Summary e.g., dates of application / hearing / notice / etc. (note whether dates are anticipated or actual); major activities (indicate whether planned, in progress and/or completed); primary reasons for possible delay, etc.
--------------------------	---

6.3 Governmental Approval activities recently performed

Please list all Governmental Approval activities that occurred since the previous report.

6.4 Governmental Approval activities expected during the current month

Please list all Governmental Approval activities that are expected to occur during the current month.

6.5 Governmental Approval Notices received from EPC Contractor

Please attach to this Monthly Progress Report copies of any notices related to Governmental Approval activities received since the previous report, whether from EPC Contractor or directly from Governmental Authorities.

7. Site Control

7.1 Table of Site Control schedule

If not obtained prior to execution of the Agreement, please provide the schedule Seller intends to follow to obtain control of the Site (e.g., purchase, lease).

Activity	Completion Date
	__/__/____ (expected / actual)
	__/__/____ (expected / actual)

7.2 Site Control activities recently performed

Please explain in detail the property acquisition activities that were performed since the previous report.

7.3 Site Control activities expected during the current month

Please explain in detail the site control activities that are expected to be performed during the current month.

8. Land Rights for the Company-Owned Interconnection Facilities

8.1 Table of Land Rights schedule for Company-Owned Interconnection Facilities

If not obtained prior to execution of the Agreement, please provide the schedule Seller intends to follow to obtain control of the Land for the Company-Owned Interconnection Facilities (e.g., purchase, lease).

Activity	Completion Date
	__/__/____ (expected / actual)
	__/__/____ (expected / actual)

8.2 Land Control activities recently performed

Please explain in detail the property acquisition activities that were performed since the previous report.

8.3 Land Control activities expected during the current month

Please explain in detail the Land control activities that are expected to be performed during the current month.

9. Design and Engineering

9.1 Design and engineering schedule

Please provide the name of the EPC Contractor, the date of execution of the EPC Contract, and the date of issuance of a full notice to proceed (or equivalent).

Please list all major design and engineering activities, both planned and completed, to be performed by Seller and the EPC Contractor.

Name of EPC Contractor / Subcontractor	Activity	Completion Date
		___/___/_____ (expected / actual)
		___/___/_____ (expected / actual)

9.2 Design and engineering activities recently performed

Please explain in detail the design and engineering activities that were performed since the previous report.

9.3 Design and engineering activities expected during the current month

Please explain in detail the design and engineering activities that are expected to be performed during the current month.

10. Major Equipment Procurement

10.1 Major equipment to be procured

Please list all major equipment to be procured by Seller or the EPC Contractor:

Equipment Description	Manufacturer	Delivery Date (indicate whether expected or actual)	Installation Date (indicate whether expected or actual)
		__/__/____ (expected / actual)	__/__/____ (expected / actual)
		__/__/____ (expected / actual)	__/__/____ (expected / actual)

Equipment Description	No. Ordered	No. Made	No. On-Site	No. Installed	No. Tested

10.2 Major Equipment procurement activities recently performed

Please explain in detail the major equipment procurement activities that were performed since the previous report.

10.3 Major Equipment procurement activities expected during the current month

Please explain in detail the major equipment procurement activities that are expected to be performed during the current month.

11. Construction

11.1 Construction activities

Please list all major construction activities, both planned and completed, to be performed by Seller or the EPC Contractor.

Activity	EPC Contractor / Subcontractor	Completion Date
		___/___/_____ (expected / actual)
		___/___/_____ (expected / actual)

11.2 Construction activities recently performed

Please explain in detail the construction activities that were performed since the previous report.

11.3 Construction activities expected during the current month

Please explain in detail the construction activities are expected to be performed during the current month.

11.4 EPC Contractor Monthly Construction Progress Report

Please attach a copy of the Monthly Progress Reports received since the previous report from the EPC Contractor pursuant to the construction contract between Seller and EPC Contractor, certified by the EPC Contractor as being true and correct as of the date issued.

12. Interconnection

12.1 Interconnection activities

Please list all major interconnection activities, both planned and completed, to be performed by Seller or the EPC Contractor.

Activity	Name of EPC Contractor / Subcontractor	Completion Date
		___/___/_____ (expected / actual)
		___/___/_____ (expected / actual)

12.2 Interconnection activities recently performed

Please explain in detail the interconnection activities that were performed since the previous report.

12.3 Interconnection activities expected during the current month

Please explain in detail the interconnection activities that are expected to be performed during the current month.

13. Startup Testing and Commissioning

13.1 Startup testing and commissioning activities

Please list all major startup testing and commissioning activities, both planned and completed, to be performed by Seller or the EPC Contractor.

Activity	Name of EPC Contractor / Subcontractor	Completion Date
		___/___/_____ (expected / actual)
		___/___/_____ (expected / actual)

13.2 Startup testing and commissioning activities recently performed

Please explain in detail the startup testing and commissioning activities that were performed since the previous report.

13.3 Startup testing and commissioning activities expected during the current month

Please explain in detail the startup testing and commissioning activities that are expected to be performed during the current month.

14. Safety and Health Reports

14.1 Accidents

Please describe all Facility-related accidents reported since the previous report.

14.2 Work stoppages

Please describe all Facility-related work stoppages from that occurred since the previous report.

Please describe the effect of work stoppages on the Facility schedule.

15. Community Outreach

Please describe all community outreach efforts undertaken since the last report.

16. Certification

I, _____, on behalf of and as an authorized representative of [_____], do hereby certify that any and all information contained in this Seller's Monthly Progress Report is true and accurate, and reflects, to the best of my knowledge, the current status of the construction of the Facility as of the date specified below.

By: _____

Name: _____

Title: _____

Date: _____

ATTACHMENT T
MONTHLY REPORTING AND DISPUTE
RESOLUTION BY INDEPENDENT AF EVALUATOR

1. Monthly Report. Commencing with the month during which the Commercial Operations Date is achieved, and for each calendar month thereafter during the Term, Seller shall provide to Company a Monthly Report in Excel, Lotus or such other format as Company may require, which Monthly Report shall include (i) the data for the calendar month in question populated into the form of "Monthly Report" below, (ii) the data for the BESS Measurement Period ending with the calendar month in question populated into the form of "BESS Measurement Period Report" below, and (iii) Seller's calculations of the performance metrics, other than the Fast Frequency Response Performance Metric, and any liquidated damages assessments for the LD Period ending with such calendar month as set forth below. Seller shall deliver such Monthly Report to Company by the fifth (5th) Business Day following the close of the calendar month in question. Seller shall deliver the Monthly Report electronically to the address provided by the Company. Company shall have the right to verify all data set forth in the Monthly Report by inspecting measurement instruments and reviewing Facility operating records. Upon Company's request, Seller shall promptly provide to Company any additional data and supporting documentation necessary for Company to audit and verify any matters in the Monthly Report.

Monthly Report

NAME OF IPP FACILITY: [Facility Name]
MONTHLY REPORT PERIOD: [Month Day, Year] to [Month Day, Year]

BESS Measurement Period Report

NAME OF IPP FACILITY: [Facility Name]
BESS MEASUREMENT PERIOD: [Month Day, Year] to [Month Day, Year]

Enter the applicable information from which the IPP is using to demonstrate satisfaction of the BESS Capacity Performance Metric during the reporting period. This can either be from a BESS Capacity Test performed during the period or taken from operational data reflecting the net output of the BESS.

Date/Time Start	Date/Time End	Total MWh delivered to the POI (A)	BESS Contract Capacity (MWh) (B)	BESS Capacity Ratio 100% x (A/B)

Enter the applicable information from which the IPP is using to demonstrate satisfaction of the RTE Performance Metric during the reporting period. This can either be from a RTE Test performed during the period or taken from operational data reflecting the charging/discharging of the BESS.

Date/Time Start	Date/Time End	Total MWh delivered to the POI during Capacity Test (A)	Charging Energy measured at POI (MWh) (B)	RTE Ratio 100% x (A ÷ B)

Enter the information for each ExcludedTime event during the reporting period. Dates and times should be entered to the nearest minute. Duration, size of reduction, maximum rated output, and equivalent hours should be rounded to 1 decimal place.

Date/Time Start (A)	Date/Time End (B)	Duration (hrs) (C) = (B-A)	Size of Reduction (MW) (D)	Maximum Rated Output (MW) (E)	Equivalent Hours (hrs) (C x D)/E
...					

Calendar hours in the reporting period: _____

Total equivalent ExcludedTime for the reporting period (from above): _____

Period Hours (PH) in the reporting period: _____

PH from the last three (3) reporting periods: _____

PH for the last four (4) reporting periods: _____

Enter the information for each Outage during the reporting period. Dates and times should be entered to the nearest minute. Duration should be rounded to 1 decimal place.

Date/Time Start	Date/Time End	Duration

(A)	(B)	(hrs) (B-A)
...		

Calendar hours in the reporting period: _____

Total Outage hours for the reporting period (from above): _____

Available Hours (AH) in the reporting period: _____

AH from the last three (3) reporting periods: _____

AH for the last four (4) reporting periods: _____

Enter the information for each Planned Deration event during the reporting period. Dates and times should be entered to the nearest minute. Duration, size of reduction, maximum rated output, and equivalent hours should be rounded to 1 decimal place.

Date/Time Start (A)	Date/Time End (B)	Duration (hrs) (C) = (B-A)	Size of Reduction (MW) (D)	Maximum Rated Output (MW) (E)	Equivalent Hours (hrs) (C x D)/E
...					

Total equivalent planned derated hours (EPDH) for the reporting period: _____

EPDH from the last three (3) reporting periods: _____

EPDH for the last four (4) reporting periods: _____

Enter the information for each Unplanned Deration event during the reporting period. Dates and times should be entered to the nearest minute. Duration, size of reduction, maximum rated output, and equivalent hours should be rounded to 1 decimal place.

Date/Time Start (A)	Date/Time End (B)	Duration (hrs) (C) = (B-A)	Size of Reduction (MW) (D)	Maximum Rated Output (MW) (E)	Equivalent Hours (hrs) (C x D)/E
...					

Total equivalent unplanned derated hours (EUDH) for the reporting period: _____

EUDH for the last three (3) reporting periods: _____

EUDH for the last four (4) reporting periods: _____

Enter the Available Hours, EPDH, EUDH, and Period Hours for the last four (4) reporting periods as calculated above.

AH (A)	EPDH (B)	EUDH (C)	PH (D)	BESS Annual Equivalent Availability Factor $100\% \times (A - B - C)/D$

Enter the information for each Forced Outage during the reporting period. Dates and times should be entered to the nearest minute. Duration should be rounded to 1 decimal place.

Date/Time Start (A)	Date/Time End (B)	Duration (hrs) (B-A)
...		

Total Forced Outage Hours (FOH) for the reporting period (from above): _____

FOH from the last three (3) reporting periods: _____

FOH for the last four (4) reporting periods: _____

Enter the FOH and EUDH for the last four (4) reporting periods as calculated above.

FOH (A)	EUDH (B)	BESS Annual Equivalent Forced Outage Factor $100\% \times (A + B)/8760$

2. Monthly Report Disagreements.

- (a) Notice of Disagreement With Monthly Report. Within ten (10) Business Days following the close of the

calendar month in question, Seller shall provide to Company the Monthly Report for such calendar month and the LD Period, the MPR Assessment Period and the BESS Measurement Period (if any) ending with such calendar month, as provided in Section 1 (Monthly Report) of this Attachment T (Monthly Reporting and Dispute Resolution by Independent AF Evaluator). Within ten (10) Business Days after Company's receipt of a Monthly Report, Company shall provide written notice to Seller of any Monthly Report Disagreement, including with respect to the data for the calendar month covered by such Monthly Report and Seller's calculation of, as applicable, (i) the PV System Equivalent Availability Factor for the LD Period ending with such calendar month, (ii) the MPR for the MPR Assessment Period ending with such calendar month, or (iii) any of the BESS Capacity Ratio, the RTE Ratio, the BESS Annual Equivalent Availability Factor or the BESS Equivalent Forced Outage Factor for the BESS Measurement Period (if any) ending with such calendar month ("Notice of Disagreement"). Together with any such Notice of Disagreement, the Company shall include its own calculations and other support for its position. If Company fails to provide a Notice of Disagreement within said 10-Business Day period, the Monthly Report provided by Seller shall be deemed to be accepted by Company and shall no longer be subject to dispute by Company or Seller.

(b) [Reserved]

(c) Submission of Monthly Report Disagreement to Independent AF Evaluator. Upon issuance of a Notice of Disagreement, the Parties shall review the contents of the Monthly Report(s) together with such Notice of Disagreement and attempt to resolve such Monthly Report Disagreement. If the Parties are able to agree on a resolution of any Monthly Report Disagreement, the resulting corrected Monthly Report(s) in question shall be set forth in a writing executed by both Parties, following which (i) such corrected Monthly Reports shall no longer be subject to dispute by either Party and (ii) to the extent such resolution of such Monthly Report Disagreement affects future Monthly Reports, such future Monthly Reports shall be prepared, and the PV System Equivalent Availability Factor, the MPR, the BESS Annual Equivalent Factor and

the BESS Annual Equivalent Forced Outage Factor in such future Monthly Reports shall be calculated, in a manner consistent with such resolution. If the Parties are unable to resolve such Monthly Report Disagreement within ten (10) Business Days after Company's issuance of such Notice of Monthly Report Disagreement, either Party may, within five (5) Business Days after the end of such 10-Business Day period, submit the unresolved Monthly Report Disagreement to an Independent AF Evaluator for resolution.

- (d) [Reserved]
- (e) Appointment of Independent AF Evaluator. If either Party decides to submit an unresolved Monthly Report Disagreement to an Independent AF Evaluator, it shall provide written notice to that effect (the "Submission Notice") to the other Party, which notice shall designate which of the engineering firms on the OEPR Consultants List is to act as the Independent AF Evaluator for purposes of resolving such dispute; provided, however, for purposes of facilitating consistency in the resolution of Monthly Report Disagreements, all Monthly Report Disagreements concerning the same Performance Metric arising out of any one or more of the twelve (12) Monthly Reports issued for a given Contract Year shall be submitted to the same Independent AF Evaluator unless such Independent AF Evaluator declines to accept any such submission(s). A Submission Notice must be provided within the 5-Business Day period provided in Section 2(c) (Submission of Monthly Report Disagreement to Independent AF Evaluator) of this Attachment T (Monthly Reporting and Dispute Resolution by Independent AF Evaluator). The Parties shall each pay fifty percent (50%) of the fees and expenses charged by the Independent AF Evaluator.
- (f) Eligibility for Appointment as Independent AF Evaluator. Both Parties agree that the engineering firms listed in Section 4(j) (Acceptable Persons and Entities) of Attachment U (Calculation and Adjustment of Net Energy Potential) are fully qualified to serve as Independent AF Evaluator. By mutual agreement between the Parties in writing, a name or names may be added to or removed from the OEPR Consultants List at

any time. In no event shall there be less than three (3) names on the OEPR Consultants List.

- (g) Participation of Parties. Promptly following the issuance of a Submission Notice as provided in Section 2(e) (Appointment of Independent AF Evaluator) of this Attachment T (Monthly Reporting and Dispute Resolution by Independent AF Evaluator), Seller and Company shall provide the Independent AF Evaluator which such data as they consider to be material to the resolution of the disputed issue(s). Seller and Company shall also provide such additional data and information as the Independent AF Evaluator may reasonably request. The Parties shall assist the Independent AF Evaluator throughout the process of resolving such dispute, including making key personnel and records available to the Independent AF Evaluator, but neither Party shall be entitled to participate in any meetings with personnel of the other Party or review of the other Party's records. However, the Independent AF Evaluator will have the right to conduct meetings, hearing or oral arguments in which both Parties are represented.
- (h) Written Decision of Independent AF Evaluator. The terms of engagement with the Independent AF Evaluator shall require the Independent AF Evaluator to issue its written decision resolving the disputed issues submitted to it within the applicable time period set forth below, which time periods are subject to any tolling that may be applicable pursuant to Section 2(i) (Sequence to Resolving Interrelated Disagreements) of this Attachment T (Monthly Reporting and Dispute Resolution by Independent AF Evaluator):
- (a) 30 Days as measured from the issuance of the Submission Notice; or
 - (b) such other time period as the Parties may agree in writing. Unless otherwise agreed by the Parties in writing:
- (i) for a Performance Metric Disagreement concerning the PV System Equivalent Availability Factor, the written decision of the Independent AF Evaluator shall set forth (aa) for the calendar month in question, the correct values for AH, EPDH, EUDH and PH to be used in calculations under Section 2.5 (PV System Equivalent Availability Factor; Liquidated Damages; Termination Damages) of this

Agreement as determined by such Independent AF Evaluator if any such values were in dispute and (bb) for the LD Period ending with the calendar month in question, the PV System Equivalent Availability Factor for such LD Period as determined by such Independent AF Evaluator if such PV System Equivalent Availability Factor was in dispute;

- (ii) for a Performance Metric Disagreement concerning the MPR, the written decision of the Independent AF Evaluator shall set forth (aa) the correct data points from the operational data set for the calendar month in question to be used in the calculation of MPR under Section 2.6(a) (Calculation of Measured Performance Ratio) for the MPR Assessment Periods that include such calendar month if any such data points were in dispute, (bb) if a MPR Test was conducted during the month in question, the correct data points from such MPR Test to be used in the calculation of MPR under Section 2.6(a) (Calculation of Measured Performance Ratio) of this Agreement for the MPR Assessment Periods that include the month preceding the month covered by the Monthly Report in question if any such data points were in dispute and (cc) for the MPR Assessment Period ending with the calendar month in question, the Measured Performance Ratio if such Measured Performance Ratio was in dispute;
- (iii) for a Performance Metric Disagreement concerning the BESS Capacity Ratio or the RTE Ratio, the written decision of the Independent AF Evaluator shall set forth the BESS Capacity Ratio and/or the RTE Ratio for the BESS Measurement Period ending with the calendar month in question;
- (iv) for a Performance Metric Disagreement concerning the BESS Annual Equivalent Availability Factor, the written decision of the Independent AF Evaluator shall set forth (aa) the correct values to be used for AH, EPDH, EUDH and PH under Attachment X (BESS Annual Equivalent Availability Factor) for the calendar month in question if any such values were in dispute and (bb) the BESS

Annual Equivalent Availability Factor for the BESS Measurement Period ending with the calendar month in question if such BESS Annual Equivalent Availability Factor was in dispute; and

- (v) for a Performance Metric Disagreement concerning the BESS Annual Equivalent Forced Outage Factor, the written decision of the Independent AF Evaluator shall set forth (aa) the correct values for FOH and EUDH under Attachment Y (BESS Annual Equivalent Forced Outage Factor) for the calendar month in question if any such values were in dispute and (bb) the BESS Annual Equivalent Forced Outage Factor for the BESS Measurement Period ending with the calendar month in question if such BESS Annual Equivalent Forced Outage Factor was in dispute.

- (i) Sequence for Resolving Interrelated Disagreements. If at the time a Performance Metric Disagreement is submitted to an Independent AF Evaluator pursuant to Section 2(e) (Appointment of Independent AF Evaluator) of this Attachment T (Monthly Reporting and Dispute Resolution by Independent AF Evaluator) there are one or more other unresolved Performance Metric Disagreements concerning the same Performance Metric and the same LD Period that are pending before a different Independent AF Evaluator, and the resolution of such other Performance Metric Disagreement(s) is necessary to the resolution of the Performance Metric Disagreement that has been newly submitted to a new Independent AF Evaluator as aforesaid, the time period for such new Independent AF Evaluator to issue its written decision resolving such newly submitted Performance Metric Disagreement shall be tolled until such pending Performance Metric Disagreement(s) have been resolved. For avoidance of doubt, it is the intent of the Parties that disagreements over performance ratio data and calculations for a given calendar month or a given BESS Measurement Period shall (i) not be subject to resolution twice and (ii) once resolved, shall not be reopened.

- (j) Final, Conclusive and Binding. The Parties acknowledge the inherent uncertainty in calculating the Performance Metrics, and hereby assume the risk of

such uncertainty and waive any right to dispute the qualification of the person or entity appointed as the Independent AF Evaluator pursuant to Section 2(e) (Appointment of Independent AF Evaluator) of this Attachment T (Monthly Reporting and Dispute Resolution by Independent AF Evaluator) and/or the appropriateness of the methodology used by Independent AF Evaluator in resolving such Performance Metric Disagreements. Without limitation to the generality of the preceding sentence, the decision of the Independent AF Evaluator as to each Performance Metric Disagreement submitted to an Independent AF Evaluator shall be final, conclusive and binding upon Company and Seller and shall not be subject to further dispute under Article 28 (Dispute Resolution) of the Agreement.

3. Periodic Review of Method of Calculating and Reporting Performance Metric. At least once per Contract Year, Company shall review the method of calculating and reporting Performance Metric under this Agreement to determine if other variables should be incorporated into such calculations. Any revisions to the Performance Metric calculations in this Agreement shall be mutually agreed to by both Seller and Company.
4. Future Changes in Reporting Requirements. Seller shall reasonably cooperate with any Company requested revisions to the Monthly Report to include additional data that may be necessary from time to time to enable Company to comply with any new reporting requirements directed by the PUC or otherwise imposed under applicable Laws.

ATTACHMENT U
CALCULATION AND ADJUSTMENT OF NET ENERGY POTENTIAL

1. Net Energy Potential.

(a) Net Energy Potential and the Intent of the Parties.

The essence of this Agreement is that Company is paying to Seller a Lump Sum Payment in exchange for Company's right to dispatch, subject to Renewable Resource Variability, the Facility's Net Energy Potential. Under this Agreement, "Net Energy Potential": (i) constitutes an estimated single number with a P-Value of 95 for annual Net Energy that could be produced by the Facility based on the estimated long-term monthly and annual total of such production over a period of ten years; (ii) is subject to adjustment from time to time as provided in this Attachment U (Calculation and Adjustment of Net Energy Potential); and (iii) as so adjusted, provides a basis for calculating and adjusting the Lump Sum Payment, as provided in Section 3 (Calculation of Lump Sum Payment) of Attachment J (Company Payments for Energy, Dispatchability and Availability of BESS) to this Agreement. It is the intent of the Parties that the estimate of Net Energy Potential, as calculated and adjusted as foresaid, should reflect the following risk allocation between the Parties under this Agreement:

(i) Seller has assumed the risk of downward adjustment to the Net Energy Potential (and hence the Lump Sum Payment) to account for any of the following circumstances:

(aa) if the Renewable Resource Baseline (as estimated on the basis of the typical meteorological year as derived from the Site's measured meteorological data) is lower than Seller had assumed when it submitted its RFP Proposal;

(bb) if the as-built design and construction of the Facility is not as efficient in generating electrical energy and delivering such electric energy to the Point of

Interconnection as Seller had assumed when it submitted its RFP Proposal; and

- (cc) if the Facility's level of operational efficiency is below the standard of comparable facilities;
- (ii) Company has assumed the risk of the following (i.e., the following are to be disregarded for purposes of estimating Net Energy Potential (and hence the Lump Sum Payment)):
 - (aa) Renewable Resource Variability; and
 - (bb) the possibility that, at any given moment, Company does not need to dispatch any or all of the electric energy that the Facility is then capable of generating and delivering to the Point of Interconnection.

The foregoing is not intended as an exhaustive list of the risks assumed by either Party under this Agreement or as a limitation on the circumstances that an OEPR Evaluator, in its professional judgment, may decide to take into account in preparing its OEPR under Section 4(e) (Terms of Engagement) of this Attachment U (Calculation and Adjustment of Net Energy Potential).

- (b) NEP RFP Projection. In its RFP Proposal, the Seller projected that the Facility would have a Net Energy Potential (as defined in this Agreement) of MWh [**Note - insert NEP from RFP proposal**] and provided the plane of array irradiance data used in arriving at the NEP RFP Projection, and Company relied on Seller's NEP RFP Projection in deciding to contract with Seller in lieu of other developers. Among the fundamentals of the bargain evidenced in this Agreement is that there will be consequences to Seller if (i) the IE Energy Assessment does not support the NEP RFP Projection and/or (ii) the operational performance of the Facility indicates a Net Energy Potential that is below the applicable thresholds set forth in this Attachment U (Calculation and Adjustment of Net Energy Potential).
- (c) NEP IE Estimate and Company-Designated NEP Estimate. Prior to the closing of the construction financing for

the Facility but in no event later than the Commercial Operations Date, the Seller shall provide Company with a copy of the IE Energy Assessment Report and the data on plane of array irradiance and corresponding power output used in arriving at the NEP IE Estimate. In addition, Seller shall obtain from the administrative agent of the Facility Lender and provide to Company, at financial close of the construction debt financing, a confirmation letter confirming to Company that the IE Energy Assessment Report including the data on plane of array of irradiance and corresponding power output used in arriving at the NEP IE Estimate provided by Seller to Company is the final energy assessment prepared for the Facility Lender as part of the Facility Lender's due diligence leading up to the Facility Lender's legally binding commitment (subject to certain conditions precedent) to provide a specific amount of financing for the Project as evidenced by the Facility Lender's execution of the Financing Documents. If the IE Energy Assessment Report fails to provide a NEP IE Estimate that is consistent with the requirements of this Agreement in all material respects, or if the data on plane of array of irradiance and corresponding power output used in arriving at the NEP IE Estimate is not provided, or if the aforementioned confirmation letter is not provided, Company shall have the option, exercisable by written notice to Seller issued no later than 30 Days, or such longer period as the Parties may agree in writing, following the first to occur of Company's receipt of (i) the IE Energy Assessment Report or (ii) notice that Company will not be provided with a copy of the IE Energy Assessment Report and the data on plane of array of irradiance and corresponding power output used in arriving at the NEP IE Estimate, to designate such Company-Designated NEP Estimate as Company, in its sole discretion, determines to be reasonable in light of the information then available to Company. In connection with Company's decision as to whether to designate a Company-Designated NEP Estimate, Company shall have the right to require Seller to pay for an energy assessment to be performed by an independent engineer selected by Company. In such case, the aforesaid 30-Day period for Company's decision to designate a Company-Designated NEP Estimate shall be tolled for the time necessary to prepare such assessment. If Company fails, within the

aforesaid 30-Day period as such period may be tolled as provided in the preceding sentence, to designate a Company-Designated NEP Estimate, the NEP RFP Projection shall constitute the First NEP Benchmark, unless the Parties agree in writing on a lower First NEP Benchmark.

- (d) NEP IE Estimate, Liquidated Damages and Seller's Null and Void Right. If the NEP IE Estimate is higher than the NEP RFP Projection, the NEP RFP Projection shall constitute the First NEP Benchmark. In any other case, Seller shall have the option to declare this Agreement null and void by written notice to Company as follows:
- (i) if (aa) the NEP IE Estimate is lower than the NEP RFP Projection and (bb) Seller issues its null and void notice to Company not later than 30 Days after issuance of the IE Energy Assessment Report; or
 - (ii) if (aa) Company exercises its right to designate a Company-Designated NEP Estimate under Section 1(c) (NEP IE Estimate and Company-Designated NEP Estimate) of this Attachment U (Calculation and Adjustment of Net Energy Potential), (bb) such Company-Designated NEP Estimate is lower than the NEP RFP Projection, and (cc) Seller issues its null and void notice to Company not later than 30 Days after Company's notice of the Company-Designated NEP Estimate.

If Seller fails to declare this Agreement null and void under the conditions set forth in either clause (i) or clause (ii) above, then: (x) the NEP IE Estimate or the Company-Designated NEP Estimate, as applicable, shall thereafter constitute the First NEP Benchmark and (y) Seller shall, within five (5) Business Days following the expiration of the applicable 30-Day period for the issuance of Seller's null and void notice, pay liquidated damages equal to \$10 for every MWh by which the NEP RFP Projection exceeds the First NEP Benchmark for the initial Contract Year.

2. Initial OEPR. Following the Initial NEP Verification Date, the Initial OEPR shall be prepared pursuant to the process

set forth in Section 4 (Preparation of OEPR) of this Attachment U (Calculation and Adjustment of Net Energy Potential) and the Initial NEP OEPR Estimate shall be as set forth in or derived from the Initial OEPR, as more fully set forth in Section 4(e) (Terms of Engagement) of this Attachment U (Calculation and Adjustment of Net Energy Potential). If the Initial NEP OEPR Estimate differs from the First NEP Benchmark, the Lump Sum Payment shall be recalculated and adjusted as provided in Section 3.ii (Lump Sum Payment During Second Benchmark Period) of Attachment J (Company Payments for Energy, Dispatchability and Availability of BESS) to this Agreement.

3. Subsequent OEPRs.

- (a) Required Subsequent OEPR. If Seller makes any changes to the Facility that involve (i) replacing any step-up transformer(s) or (ii) making any other changes (e.g., changing the characteristics of the Facility equipment or the specifications used in the IRS) that Company reasonably determines require an updated IRS, then Seller shall also be required to have a subsequent OEPR prepared as of the first Day of the calendar month following the second anniversary of the date such change to the Facility was completed.
- (b) Voluntary Subsequent OEPR. Without limitation to the generality of Section 3(a) (Required Subsequent OEPR) of this Attachment U (Calculation and Adjustment of Net Energy Potential), if the Seller makes any changes to the Facility (e.g., replacing original equipment) that does not trigger a required Subsequent OEPR but which changes Seller has reasonable grounds to believe will improve the Facility's Net Energy Potential, Seller shall have a one-time option, exercisable by written notice to Company issued not less than 120 Days prior to the Applicable NEP Verification Date, of having a subsequent OEPR prepared as of a date no sooner than 12 months following completion of the then most recent OEPR.
- (c) Subsequent OEPR and Adjustment to Lump Sum Payment. If the Subsequent NEP OEPR Estimate differs from the Most Recent Prior NEP Benchmark, the Lump Sum Payment shall be recalculated and adjusted as provided in Section 3.iii (Lump Sum Payment Following Second Benchmark Period) of Attachment J (Company Payments

for Energy, Dispatchability and Availability of BESS) to this Agreement.

4. Preparation of OEPR. The following provisions apply to the Initial OEPR and any Subsequent OEPR:

- (a) Selection of OEPR Evaluator. No later than 90 Days prior to the Applicable NEP Verification Date, Company and Seller shall select, in accordance with the terms of this Section 4(a) (Selection of OEPR Evaluator), an independent engineering firm from the firms listed on the OEPR Consultants List (the "OEPR Evaluator") to prepare an operational energy production report ("OEPR"). Each party shall select the names of two (2) firms from the OEPR Consultants List. If there is mutual agreement on one or both of the named firms, then the Seller shall select one of the named firms to serve as the OEPR Evaluator. If there is no agreement on any of the named firms, then Seller shall select one of the firms named by the Company.
- (b) Eligibility for Appointment as OEPR Evaluator. Both Parties agree that the engineering firms listed in Section 4(j) of this Attachment U (Calculation and Adjustment of Net Energy Potential) are fully qualified to prepare the OEPR. By mutual agreement between the Parties in writing, a name or names may be added to or removed from the OEPR Consultants List at any time. In no event shall there be less than three (3) names on the OEPR Consultants List.
- (c) OEPR Period of Record. It is the intent of the Parties that the OEPR shall be prepared using measured meteorological and production data from the OEPR Period of Record. However, although the OEPR Period of Record is a twelve-month period, the Parties acknowledge that, in certain circumstances (e.g., Force Majeure), there may not be twelve months of data available for the OEPR Period of Record. In such case, (i) it is the intent of the Parties that the OEPR be prepared using such measured meteorological and production data that is available from the OEPR Period of Record and (ii) Parties may, by written agreement, direct the OEPR Evaluator to use such additional data outside of the OEPR Period of Record as the Parties may agree. The preceding sentence does not constitute a limitation on the professional

judgment of the OEPR Evaluator as to the appropriateness of using measured meteorological and/or production from outside of the OEPR Period of Record.

- (d) Participation of Parties. Promptly following the Applicable NEP Verification Date, Seller and Company shall provide the OEPR Evaluator with such data from the OEPR Period of Record as they consider to be material to the preparation of the OEPR. Seller and Company shall also provide such additional data and information as the OEPR Evaluator may reasonably request. The Parties shall assist the OEPR Evaluator throughout the process of preparing the OEPR, including making key personnel and records available to the OEPR Evaluator, but neither Party shall be entitled to participate in any meetings with personnel of the other Party or review of the other Party's records. However, the OEPR Evaluator will have the right to conduct meetings, hearings or oral arguments in which both Parties are represented. Seller and Company shall have forty-five (45) Days from issuance of the draft OEPR Report to review and provide feedback to the OEPR Evaluator on such report.
- (e) Terms of Engagement. Upon selection of the OEPR Evaluator, as set forth in this Attachment U (Calculation and Adjustment of Net Energy Potential), the Seller shall retain and contract with the OEPR Evaluator in accordance with the terms of this Attachment U (Calculation and Adjustment of Net Energy Potential). The OEPR Evaluator's scope of work and expected deliverables for all OEPRs must be acceptable to Company and shall, among other things, require the OEPR Evaluator to provide (i) an estimated single number with a P-Value of 95 for annual Net Energy that could be produced by the Facility based on the estimated long-term monthly and annual total of such production over a period of ten years; (ii) the data on plane of array of irradiance and corresponding power output used in arriving at the aforementioned estimated annual Net Energy; (iii) the GPR Performance Metric as provided in Section 2.6(b)(ii) (Commencing With Initial OEPR) or Section 2.6(b)(iii) (Commencing With First Subsequent OEPR and Thereafter) of this Agreement, as applicable; and (iv) any additional information that may be reasonably required by a Party

with respect to the methodology used by the OEPR Evaluator to reach its conclusion. The provisions of this Attachment U (Calculation and Adjustment of Net Energy Potential) do not impose a limit on the OEPR Evaluator's professional judgment as to what other estimates (if any) to include in the OEPR. Without limiting the professional judgment of the OEPR Evaluator in estimating the Net Energy Potential and GPR Performance Metric, the following is a general description of how the Parties anticipate that the OEPR Evaluator will proceed:

The purpose of an OEPR is to implement the intent of the Parties as set forth in Section 1(a) (Net Energy Potential and the Intent of the Parties) of this Attachment U (Calculation and Adjustment of Net Energy Potential) by evaluating (i) whether, when the Renewable Resource Baseline (as estimated by the OEPR Evaluator on the basis of the typical meteorological year as derived from the Site's measured meteorological data) is present and the Facility is in Full Dispatch, the Facility is capable of doing what the Parties expected the Facility to do: i.e., generating and delivering to the Point of Interconnection electric energy in an amount consistent with the then applicable Net Energy Potential of the Facility (i.e., the estimate of Net Energy Potential then being used to calculate the monthly Lump Sum Payment pursuant to Section 3 (Calculation of Lump Sum Payment) of Attachment J (Company Payments for Energy, Dispatchability and Availability of BESS to this Agreement); and (ii) if the Facility is not doing what the parties expected in this regard, identifying a new estimated single number with a P-Value of 95 for annual Net Energy that could be generated and delivered by the Facility based on the estimated long-term monthly and annual total of such production over a period of the next ten years.

At a high level, the analysis relies on reported Actual Output (i.e., energy delivered to the Point of Interconnection) during the OEPR Period of Record to estimate Facility performance over a future evaluation period of ten years. The data from the OEPR Period of Record are first quality screened and evaluated. One-time events are assessed and removed from the record where appropriate. Values for potential energy are then calculated from the reported energy production measured at the Point of Interconnection by adjusting for 100% availability and undispached energy. Suitable long-term reference data sets are then identified by analyzing the reference for irradiance and the normalized values for potential energy production at the Point of Interconnection over the OEPR Period of Record. Relationships between selected long-term reference irradiance data sets and normalized values for potential energy production at the Point of Interconnection are used to calculate long-term values for such on a monthly and annual basis. Finally, estimates of future Facility availability (taking into account anticipated maintenance) and losses (such as system degradation and balance of plant losses) are applied in order to calculate the Net Energy Potential. For this purpose, no reductions are made for future estimates of energy that Company may choose not to dispatch. If a copy of the IE Energy Assessment Report is available to the OEPR Evaluator, the OEPR Evaluator should review such Report before commencing preparation of the OEPR and evaluate whether it is appropriate for the OEPR Evaluator to take into account any of the work reflected in the IE Energy Assessment Report.

- (f) Timeline and Fees. The terms of engagement with the OEPR Evaluator shall require the OEPR Evaluator to issue an OEPR that shall include a NEP OEPR Estimate and a Guaranteed Measured Performance Ratio Benchmark within 30 Days following the NEP Applicable

Verification Date ("First OEPR"). The Parties shall each pay fifty percent (50%) of the fees and expenses charged by the OEPR Evaluator in connection with the Initial OEPR. For the Initial OEPR, the OEPR Evaluator's fees and costs must be acceptable to Company. Seller shall pay all of the fees and expenses charged by the OEPR Evaluator in connection with any Subsequent OEPR. Seller shall also pay for any reasonable internal fees and costs incurred by the Company as a result of its participation in the process set forth in Section 4(d) (Participation of Parties) of this Attachment U (Calculation and Adjustment of Net Energy Potential).

- (g) Review of the First OEPR Evaluator Report. In the event Company or Seller does not agree with the NEP OEPR Estimate or GPR Performance Metric determined by the First OEPR Evaluator, Seller or Company may, within 30 Days of issuance of the First OEPR, engage, at its own cost, a different expert evaluator from the OEPR Consultants List (the "Second OEPR Evaluator") to prepare a second OEPR that shall include a NEP OEPR Estimate or GPR Performance Metric, as applicable ("Second OEPR"). The terms of engagement with the Second OEPR Evaluator shall require the Second OEPR Evaluator to issue the Second OEPR within 60 Days following the date of its appointment. In the event the NEP OEPR Estimates or GPR Performance Metric, as applicable, provided by the First OEPR Evaluator and the Second OEPR Evaluator are different then, within ten (10) Days of the issuance of the Second OEPR, the Parties shall, with the two evaluators, confer in an attempt to mutually agree upon a NEP OEPR Estimate or GPR Performance Metric, as applicable ("OEPR Conference").
- (h) Review of the Second OEPR Evaluator Report. If the Parties are unable to agree upon an NEP OEPR Estimate or GPR Performance Metric, as applicable, within 30 Days of the OEPR Conference, then within ten (10) Days thereafter the First OEPR Evaluator and Second OEPR Evaluator shall, by mutual agreement, select a third firm from the OEPR Consultants List to act as an independent OEPR Evaluator ("Third OEPR Evaluator"). The Third OEPR Evaluator shall not be a person from the same entity as the First OEPR Evaluator or the Second OEPR Evaluator. The Parties shall direct the

Third OEPR Evaluator to review the First OEPR and Second OEPR and select one as the final and binding NEP OEPR Estimate and/or GPR Performance Metric, as applicable ("Third OEPR"). The Third OEPR Evaluator shall complete its review and selection of the NEP OEPR Estimate within thirty (30) Days following his or her retention. If the Third OEPR Evaluator selects the First OEPR, then the Party requesting the Second OEPR shall pay for the cost of the Third OEPR. If the Third OEPR Evaluator selects the Second OEPR, then the Parties shall each pay fifty percent (50%) of the fees and expenses charged by the Third OEPR Evaluator in connection with the Third OEPR.

- (i) Final, Binding and Conclusive. The Parties acknowledge the inherent uncertainty in estimating the Net Energy Potential and GPR Performance Metric and hereby assume the risk of such uncertainty and waive any right to dispute any of the qualification of the person or entity appointed as the OEPR Evaluator pursuant to Section 4(a) (Selection of OEPR Evaluator) and Section 4(b) (Eligibility for Appointment as OEPR Evaluator) of this Attachment U (Calculation and Adjustment of Net Energy Potential) of this Agreement, the appropriateness of the methodology used by OEPR Evaluator in preparing the OEPRs, the NEP OEPR Estimate and/or the GPR Performance Metric. Without limitation to the generality of the preceding sentence, the determination of the NEP OEPR Estimate and GPR Performance Metric in the First OEPR, Second OEPR (if applicable), or final decision of the Third OEPR Evaluator (if applicable) shall be final, conclusive and binding upon Company and Seller and shall not be subject to further dispute under Article 28 (Dispute Resolution) of the Agreement; provided that, nothing in this Section 4(i) (Final, Binding and Conclusive) of this Attachment U (Calculation and Adjustment of Net Energy Potential) shall preclude Seller from engaging an OEPR Evaluator to issue a Subsequent OEPR as allowed pursuant to Section 3 (Subsequent OEPRs) of this Attachment U (Calculation and Adjustment of Net Energy Potential).
- (j) Acceptable Persons and Entities. The OEPR Evaluator and Second OEPR Evaluator shall be selected from the following engineering firms listed below, subject to such additions or deletions effectuated by the Parties

as provided in Section 2(f) (Eligibility for Appointment as Independent AF Evaluator) of Attachment T (Monthly Reporting and Dispute Resolution by Independent AF Evaluator) to this Agreement and Section 4(b) (Eligibility for Appointment as OEPR Evaluator) of this Attachment U (Calculation and Adjustment of Net Energy Potential):

DNV GL

UL

Black & Veatch

Leidos Engineering

Attachment V
SUMMARY OF MAINTENANCE AND INSPECTION PERFORMED
IN PRIOR CALENDAR YEAR

(See Article 5)

DATE WORK ORDER SUBMITTED: 06/28/96
WO#: 11451
EQUIPMENT #: 1CCF-TNK-1
EQUIPMENT DESCRIPTION: AMMONIA STORAGE TANK 1
PROBLEM DESCRIPTION: PURCHASE EMERGENCY ADAPTER FITTINGS FOR
UNLOADING GASPRO TANKS TO STORAGE TANK

WORK PERFORMED: PURCHASED THE NEW ADAPTERS AND VERIFIED THEIR
OPERATION.

COMPLETION DATE: 06/28/96
WORK ORDER COMPLETED BY: AA

-----END OF CURRENT WORK ORDER-----

DATE WORK ORDER SUBMITTED: 05/19/96
WO#: 11136
EQUIPMENT #: 1WSA-BV-12
EQUIPMENT DESCRIPTION: MAKE-UP PI ISOLATION
PROGRAM DESCRIPTION: 'D' MAKE-UP PUMP PI ISOLATION FITTING LEAKING
ON SPOOL SIDE

WORK PERFORMED: REMOVED AND REPLACED FITTINGS AND FLANGES WITH
STAINLESS STEEL. THIS WORK WAS DONE DURING PUMP OVERHAUL ON WO
1374. JH

COMPLETION DATE: 06/28/96
WORK ORDER COMPLETED BY: BB

-----END OF CURRENT WORK ORDER-----

ATTACHMENT W
BESS TESTS

Prior to achieving Commercial Operations and in each BESS Measurement Period, unless waived by Company, Seller shall demonstrate that the BESS satisfies the following:

Maintains output provided by the Company through a control setpoint, as measured at the Point of Interconnection, and is able to continuously dispatch the full BESS Contract Capacity ("BESS Capacity Test").

Demonstrates the charging/discharging requisite to satisfy the performance standard set forth in Section 3(w) (Round Trip Efficiency) of Attachment B (Facility Owned by Seller) ("RTE Test").

The RTE Test requires measurement of Charging Energy at the Point of Interconnection (MWh from the grid) from BESS 0% State of Charge to bring the BESS to a 100% State of Charge, followed by measurement at the Point of Interconnection of the MWh delivered to the grid to bring the BESS to a 0% State of Charge. The RTE Test will be conducted concurrently with the BESS Capacity Test.

The BESS Capacity Test can only be performed when the BESS is at the lower of: (i) its maximum State of Charge or (ii) 100% State of Charge prior to the start of the BESS Capacity Test and during the BESS Capacity Test the Company Dispatch allows for continuous dispatch of the BESS to 0% State of Charge with energy delivered to the Point of Interconnection.

For the purposes of evaluating the BESS Capacity Test, the "BESS Capacity Ratio" shall be equal to the number, expressed as a percentage, equal to the total MWh delivered to the Point of Interconnection during the BESS Capacity Test, divided by the BESS Contract Capacity. Further, the BESS Capacity Test will be deemed to be "passed" or "satisfied" to the extent the BESS Capacity Ratio is not less than **100%** (the "BESS Capacity Performance Metric").

For the purposes of evaluating the RTE Test, the RTE Ratio shall be equal to the number, expressed as a percentage, equal to the total MWh delivered to the Point of Interconnection during the BESS Capacity Test, divided by the "Charging Energy" measured at the Point of Interconnection. For purposes of the RTE Test, the

charging cycle shall begin when the BESS is at a 0% State of Charge prior to the commencement of the BESS Capacity Test and the Charging Energy is the amount of energy imported from the grid, as measured at the Point of Interconnection, that brings the BESS to a 100% State of Charge. The formula is $RTE\ Ratio = \frac{MWh\ discharge}{MWh\ charge}$. The RTE Test will be deemed to have been "passed" or "satisfied" to the extent the RTE Ratio is not less than the performance standard (the "RTE Performance Metric") set forth in Section 3(w) (Round Trip Efficiency of Attachment B (Facility Owned by Seller)).

Except for the BESS Capacity Test conducted prior to Commercial Operations, Seller shall, in lieu of conducting a BESS Capacity Test, be permitted to demonstrate satisfaction of the BESS Capacity Performance Metric by reference to the operational data reflecting the net output of the BESS from the Point of Interconnection for such BESS Measurement Period.

Except for the RTE Test conducted prior to Commercial Operations, Seller shall, in lieu of conducting a RTE Test, be permitted to demonstrate satisfaction of the RTE Performance Metric by reference to the operational data reflecting the charging/discharging of the BESS from the Point of Interconnection during such BESS Measurement Period.

Any BESS Capacity Test or RTE Test (each a "BESS Test" and collectively, the "BESS Tests"), other than where the BESS Capacity Performance Metric or RTE Performance Metric, as applicable, is demonstrated by reference to operational data as provided below, shall be performed at a time reasonably requested by the Company in its sole discretion. For purposes of the preceding sentence, the PV System may be shutdown to ensure there are no restrictions or limitations imposed that would lower the maximum output of the BESS, provided that any such shutdown of the PV System would be considered Reserve Shutdown Hours for the purpose of calculation of the PV System Equivalent Availability Factor pursuant to Section 2.5(a) (Calculation of the PV System Equivalent Availability Factor). Within a BESS Measurement Period, Seller shall be permitted up to a total of three (3) BESS Tests to demonstrate satisfaction of the BESS Capacity Performance Metric and the RTE Performance Metric for such BESS Measurement Period, unless additional such tests are authorized by Company. Company shall provide notice to Seller no less than three (3) Business Days prior to conducting a BESS Test.

At any time prior to conducting the third BESS Capacity Test noticed by Company for a BESS Measurement Period, Seller may demonstrate satisfaction of the BESS Capacity Performance Metric by reference to operational data reflecting the net output of the BESS from the Point of Interconnection for such BESS Measurement Period. If, during a BESS Measurement Period, Seller both fails to pass a BESS Capacity Test noticed by Company and fails to demonstrate satisfaction of the BESS Capacity Performance Metric by reference to operational data for such BESS Measurement Period, the BESS shall nevertheless be deemed to have satisfied the BESS Capacity Performance Metric for the applicable BESS Measurement Period if either (i) Company failed to notice at least three BESS Capacity Tests during such BESS Measurement Period, or (ii) Seller was unable to perform at least two (2) such noticed BESS Capacity Tests during such BESS Measurement Period due to (a) conditions on the Company System other than Seller-Attributable Non-Generation or (b) an act or omission by Company.

At any time prior to conducting the third RTE Test noticed by Company for a BESS Measurement Period, Seller may demonstrate satisfaction of the RTE Performance Metric by reference to operational data reflecting charging/discharging of the BESS from the Point of Interconnection during such BESS Measurement Period. If, during a BESS Measurement Period, Seller both fails to pass a RTE Test noticed by Company and fails to demonstrate satisfaction of the RTE Performance Metric by reference to operational data for such BESS Measurement Period, the BESS shall nevertheless be deemed to have satisfied the RTE Performance Metric for the applicable BESS Measurement Period if either (i) Company failed to notice at least three RTE Tests during such BESS Measurement Period, or (ii) Seller was unable to perform at least two (2) such noticed RTE Tests during such BESS Measurement Period due to (a) conditions on the Company System other than Seller-Attributable Non-Generation or (b) an act or omission by Company.

Company shall have the right to attend, observe and receive the results of all BESS Tests. Seller shall provide to Company the results of each BESS Test (including time stamped graphs of system performance based in operational data or test data) no later than ten (10) Business Days after the performance of such BESS Test.

ATTACHMENT X
BESS ANNUAL EQUIVALENT AVAILABILITY FACTOR

To the extent the Commercial Operations Date occurs on a date other than the first day of a BESS Measurement Period, the period between the Commercial Operations Date and the first day of the next BESS Measurement Period if any, shall be ignored for purposes of this BESS Availability Test.

For the purposes of calculating the BESS Annual Equivalent Availability Factor for the first three (3) full BESS Measurement Periods in the first Contract Year, the calculation will assume that the BESS is one hundred percent (100%) available for the remaining hours of the Contract Year.

"BESS Annual Equivalent Availability Factor" shall be calculated as follows:

$$\begin{array}{l} \text{BESS Annual} \\ \text{Equivalent} \\ \text{Availability} \\ \text{Factor} \end{array} = 100\% \times \frac{AH-EPDH-EUDH}{PH}$$

Where:

PH is period hours (8760 hours; except leap year is 8784) minus ExcludedTime.

Available Hours (AH) is the number of hours that the BESS is not on Outage. It is sum of all Service Hours (SH) + Reserve Shutdown Hours (RSH).

An "Outage" exists whenever the entire BESS is offline and unable to charge or discharge electric energy and is not in Reserve Shutdown state.

Service Hours (SH) is the number of hours during the LD Period the BESS is online and (i) charging from the PV System or (ii) discharging electric energy to the Company System.

Reserve Shutdown Hours (RSH) is the number of hours the BESS is available but not charging or discharging electric energy or is offline for reasons other than Seller-Attributable Non-Generation.

EPDH is the equivalent planned derated hours, including Planned Derations (PD) and Maintenance Derations (D4). A Planned Deration is when the BESS experiences a Deration scheduled well in advance and for a predetermined duration. A Maintenance Deration is a Deration that can be deferred beyond the end of the next weekend (Sunday at midnight or before Sunday turns into Monday) but requires a reduction in capacity before the next Planned Deration (PD). Each individual Deration is transformed into equivalent full outage hour(s) by multiplying the actual duration of the Deration (hours) by (i) the size of the reduction (MW) divided by (ii) Maximum Rated Output. These equivalent hour(s) are then summed.

EUDH is the equivalent unplanned derated hours. An Unplanned Deration (Forced Derating) occurs when the BESS experiences a Deration that requires a reduction in availability before the end of the nearest following weekend. Unplanned Derations include only those due to Seller-Attributable Non-Generation or those by Company pursuant to Section 8.3 (Company Rights of Dispatch). Each individual Unplanned Deration is transformed into equivalent full outage hour(s) by multiplying the actual duration of the Deration (hours) by (i) the size of the reduction (MW) divided by (ii) the Maximum Rated Output. These equivalent hour(s) are then summed.

A "Deration" exists when, due to Seller-Attributable Non-Generation, the BESS is available but at less than full capacity. Each individual Deration is transformed into equivalent full outage hour(s) by multiplying the actual duration of the derating (hours) by the size of the reduction (MW) and dividing by the Maximum Rated Output. These equivalent hour(s) are then summed. For the avoidance of doubt, if the BESS is in an Outage it cannot also be in a Deration.

ExcludedTime is unavailability as a result of the entire BESS or a portion of the BESS being unavailable due to Force Majeure. The hours and/or equivalent hours of ExcludedTime shall not be added to Available Hours and shall be subtracted from Period Hours. Each event that counts as ExcludedTime is transformed into equivalent full outage hour(s) by multiplying the

actual duration of the event by the size of the reduction (MW) and dividing by Maximum Rated Output. These hour(s) are then summed.

The effect of Force Majeure is taken into account in calculating the BESS Annual Equivalent Availability Factor over a 12 calendar month period as follows: When such 12 month period contains a month during which the BESS or a portion of the BESS is unavailable due to Force Majeure, then such month shall be excluded from the 12 month period and the calculation period shall be extended back in time to include the next previous month during which there was no such unavailability of the BESS or a portion thereof due to Force Majeure.

The following examples are provided as illustrative examples only:

Example A: BESS System was continuously available, with no maintenance or Unplanned (Forced) Derations. In this case AH = 8760, EPDH and EUDH = 0 hours

$$\text{BESS EAF} = 100\% \times \frac{8,760-0}{8,760} = 100\%$$

Example B: Maintenance Deration Hours = 168 hours

Equivalent Unplanned (Forced) Derated Hours = 100 hours

$$\text{AH} = 8,760 - 168 = 8,592$$

$$\text{BESS EAF} = 100\% \times \frac{8,592-100}{8,760} = 96.9\%$$

ATTACHMENT Y
BESS ANNUAL EQUIVALENT FORCED OUTAGE FACTOR

$$EFOF = 100\% \times \frac{(FOH + EUDH)}{8760}$$

Where:

Equivalent Unplanned (Forced) Derated Hours (EUDH) is the equivalent unplanned derated hours. Each (Unplanned Forced) Deration of the BESS is transformed into equivalent full outage hour(s). This is calculated by multiplying the actual duration of the Deration (hours) by (i) the size of the reduction (MW) divided by (ii) the Maximum Rated Output. These equivalent hour(s) are then summed for the BESS Measurement Period and added to the sum of the EUDH for the immediately preceding three (3) full BESS Measurement Periods.

- Hours of Deration x Size of Reduction)/Maximum Rated Output

Forced Outage Hours (FOH) = Sum of all hours experienced during Forced Outages during the applicable BESS Measurement Period and the sum of all hours experienced during Forced Outages during the immediately preceding three (3) full BESS Measurement Periods, in each case caused by Seller-Attributable Non-Generation.

Unplanned (Forced) Derating: A Deration that requires a reduction in capacity of the BESS before the end of the nearest following weekend.

Unplanned (Forced) Outage: An outage that requires removal of the entire BESS from service before the end of the nearest following weekend that is not planned.

EXAMPLE CALCULATION:

Assume a 50 MW BESS that for the BESS Measurement Period in question was completely out of service for 50 hours. For the BESS Measurement Period in question, it also had the following deratings:

Duration of Derating	MW Size Reduction
100 Hours	25 MW
20 Hours	20 MW
50 Hours	5 MW

During the three preceding BESS Measurement Periods, the BESS had a total of 150 Forced Outage Hours and a total of 100 Equivalent Forced Derated Hours.

FOH = 50 hours + 150 hours = 200 hours

EUDH = ((100x25)/50)+((20x20)/50)+((50x5)/50)+100 = 163 hours

$$EFOF = 100\% \times \frac{(200 + 163)}{8760} = 4.1\%$$