

BEFORE THE PUBLIC UTILITIES COMMISSION
OF THE STATE OF HAWAII

In The Matter of the Application of)
)
HAWAIIAN ELECTRIC COMPANY, INC.,)
HAWAII ELECTRIC LIGHT COMPANY, INC.)
MAUI ELECTRIC COMPANY, LIMITED)
)
For Approval to Establish a Rule to Implement)
a Community-Based Renewable Energy Program,)
and Other Related Matters.)
_____)

DOCKET NO. 2015-0389

**THE HAWAIIAN ELECTRIC COMPANIES’
COMMUNITY BASED RENEWABLE ENERGY (CBRE) - PHASE 2
TARIFF AND APPENDICES, AND RFPS AND MODEL CONTRACTS
FOR LMI CUSTOMERS, MOLOKAI AND LANAI**

Book 4 of 14

Filed September 8, 2020

EXHIBIT 9

Draft RFP for Variable Renewable Dispatchable
Generation Paired with Energy Storage and CBRE
for the Island of Lanai

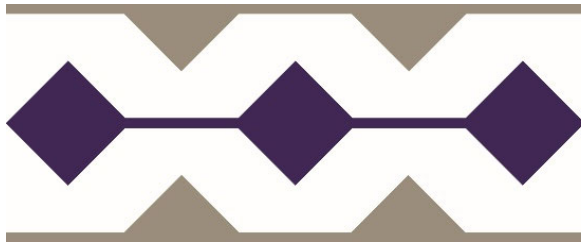

**Maui
Electric**

DRAFT

REQUEST FOR PROPOSALS

FOR

VARIABLE RENEWABLE DISPATCHABLE GENERATION

PAIRED WITH ENERGY STORAGE

AND

COMMUNITY-BASED RENEWABLE ENERGY

ISLAND OF LĀNA‘I

SEPTEMBER 8, 2020

Docket No. 2015-0389

This Request for Proposals (“RFP”) is a DRAFT only. Maui Electric Company, Ltd. (“Maui Electric”) will employ a competitive bidding process to select renewable energy projects including Community Based Renewable Energy consistent with the State of Hawai‘i Public Utilities Commission’s (“PUC”) Competitive Bidding Framework. Under the Competitive Bidding Framework. Maui Electric files the initial draft RFP with the (PUC). Then, Maui Electric sought input from prospective Proposers and other stakeholders through a Technical Conference as described in the draft RFP and modified the draft RFP to the extent feasible to address input received in order to foster a robust competitive process. The proposed final RFP is being submitted to the PUC for approval and is subject to further revision based upon direction received from the PUC. After approval by the PUC, Maui Electric will issue the final RFP.

Table of Contents

Chapter 1: Introduction and General Information	1
1.1 Authority and Purpose of the Request for Proposals	2
1.2 Scope of the RFP	2
1.3 Competitive Bidding Framework	4
1.4 Role of the Independent Observer	4
1.5 Communications Between the Company and Proposers – Code of Conduct Procedures Manual.....	5
1.6 Company Contact for Proposals	6
1.7 Proposal Submittal Requirements.....	6
1.8 Proposal Fee.....	7
1.9 Procedures for the Self-Build or Affiliate Proposals	8
1.10 Dispute Resolution Process.....	10
1.11 No Protest or Appeal.....	11
1.12 Modification or Cancellation of the Solicitation Process	11
1.13 Community Outreach.....	11
Chapter 2: Resource Needs and Requirements	11
2.1 Performance Standards	11
2.2 Distribution-Level System Information.....	12
2.3 Interconnection to the Company System	12
Chapter 3: Instructions to Proposers.....	13
3.1 Schedule for the Proposal Process	13
3.2 Company RFP Website / Electronic Procurement Platform.....	14
3.3 Information Exchange.....	15
3.4 Preparation of Proposals	15
3.5 Organization of the Proposal	16
3.6 Proposal Limitations	16
3.7 Proposal Compliance and Bases for Disqualification.....	16
3.8 Power Purchase Agreement	17
3.9 Pricing Requirements.....	18
3.10 Project Description.....	19
3.11 Project Site	20

3.12	Confidentiality	21
3.13	Credit Requirements Under the PPA	22
Chapter 4: Evaluation Process and Evaluation Criteria		22
4.1	Proposal Evaluation and Selection Process	22
4.2	Eligibility Requirements Assessment	25
4.3	Threshold Requirements Assessment	26
4.4	Evaluation – Price and Non-Price Analysis.....	27
4.5	Selection of the Final Award Group	34
Chapter 5: Post Evaluation Process		35
5.1	Interconnection Requirements Study Process.....	35
5.2	Contract Negotiation Process.....	36
5.3	Final Award Group Commitments.....	36
5.4	Greenhouse Gas Emission Analysis	38
5.5	PUC Approval of PPA	38
5.6	Facility In-Service.....	39

List of Appendices

Appendix A	Definitions
Appendix B	Proposer's Response Package / Project Interconnection Data Request
Appendix C	Code of Conduct Procedures Manual
Appendix D	PowerAdvocate User Information
Appendix E	Mutual Confidentiality and Non-Disclosure Agreement
Appendix F	Description of the Pūlama Site
Appendix G	Self-Build Option and Self Build Option Team Certification Form
Appendix H	Interconnection Facilities and Cost Information
Appendix I	Rule 19 Tariff
Appendix J	Rule 29 Tariff
Appendix K	Lāna'i Community Comments
Appendix L	Lāna'i RDG PPA (PV+Storage only)
Appendix M	RESERVED
Appendix N	RESERVED
Appendix O	Grid Needs Assessment

Chapter 1: Introduction and General Information

Maui Electric Company, Ltd. (“Maui Electric” or the “Company”) seeks proposals for the supply of qualified variable renewable dispatchable generation paired with energy storage for the Maui Electric System on the island of Lāna‘i in accordance with this Request for Proposals (“RFP”). The total amount of variable renewable dispatchable generation being solicited in this RFP is 35,800 megawatt hours (“MWh”) annually of photovoltaic (“PV”) paired with energy storage in a single project. The energy storage must be sized to store at least 70 percent of the photovoltaic energy.¹ Of the total amount of capacity being solicited a minimum of 3 MW must be dedicated to Community-Based Renewable Energy (“CBRE”). The total targeted amount assumes Lāna‘i Sustainability Research (“LSR”) and Mānele Bay Combined Heat and Power (“CHP”) facilities are no longer available as further described in this RFP.

The Company or its Affiliates may submit a Proposal in response to this RFP subject to the requirements of this RFP.

The Company seeks a PV project that is paired with an energy storage system in this RFP. The Company intends to contract for a single project through this RFP using its Model Renewable Dispatchable Generation Power Purchase Agreement (“RDG PPA”), which treats variable renewable generation facilities as fully dispatchable. The Company has created a PV + BESS (“battery energy storage system”) version of its RDG PPA attached as Appendix L to this RFP.²

The successful Proposer will provide variable renewable dispatchable generation paired with energy storage to the Company pursuant to the terms of the RDG PPA, which will be subject to review and approval by the State of Hawai‘i Public Utilities Commission (“PUC”).

The Company’s Model RDG PPA employs an innovative contracting mechanism which is very different than traditional PPA structures. Proposers are instructed to thoroughly review the Model RDG PPA attached as Appendix L. The structure of the RDG PPA intends to provide payments to the Proposer by the Company on a monthly lump sum basis, based upon the energy potential of the facility, regardless of the actual energy dispatched. In exchange, the utility maintains full dispatch control of the Facility as needed. Under the RDG PPA, each Facility must meet certain requirements to receive the full lump sum payment each month. These requirements ensure that each plant is available to the Company for dispatch to meet system needs.

The Company will evaluate Proposals using the evaluation and selection process described in Chapter 4. The Company will evaluate and select a Proposal based on both price and non-price factors that impact the Company, its customers, and communities affected by the proposed Project.

All requirements necessary to submit a Proposal(s) are stated in this RFP. A description of the technical requirements for Proposers is included in the body of this RFP, Appendix B, and in the RDG PPA attached as Appendix L.

¹ For example, 17.5MW/35,000MWh of PV paired with 17.5MW/70MWh energy storage or 14MW/35,800 MWh of PV paired with 17.5 MW/70MWh energy storage.

² The RDG PPA for PV + BESS is available on the Company’s RFP website and through the Electronic Procurement Platform for the RFP.

All capitalized terms used in this RFP shall have the meaning set forth in the glossary of defined terms attached as Appendix A. Capitalized terms that are not included in Appendix A shall have the meaning ascribed in this RFP.

1.1 Authority and Purpose of the Request for Proposals

- 1.1.1 This RFP is issued in response to Order No. 36776 issued on November 15, 2019 in Docket No. 2019-0178 and Order No. 37070 issued on April 20, 2020 and Order No. 37139 issued on May 14, 2020 in Docket No. 2015-0389 as part of a procurement process established by the PUC. On June 8, 2020, the Company filed a letter in Docket No. 2019-0178 explaining its intention to combine its Request for Proposals for Variable Renewable Dispatchable Generation Paired with Energy Storage, Island of Lāna‘i with the Community Based Renewable Energy Request for Proposals for the Island of Lāna‘i specified in Order No. 37070.
- 1.1.2 This RFP is subject to Decision and Order (“D&O”) No. 23121 in Docket No. 03-0372 (To Investigate Competitive Bidding for New Generating Capacity in Hawai‘i), which sets forth the PUC’s Framework for Competitive Bidding (“Framework” or “Competitive Bidding Framework”).
- 1.1.3 Proposers should review Appendix O, Grid Needs Assessment, to inform Proposers as to the system needs and costs based on inputs and assumptions developed through the Company’s integrated grid planning process, and recent renewable dispatchable generation procurements.³ The Grid Needs Assessment is intended to inform the development of their Proposals that best meets the needs of the system.

1.2 Scope of the RFP

- 1.2.1 The targeted amount of variable renewable dispatchable generation assumes both the LSR and CHP facilities will be removed from service. The Company consulted with the Independent Observer during the selection of the targeted amount of variable renewable dispatchable generation and the modeling assumptions, including assumptions of maximum displacement of fossil generation.
- 1.2.2 The Company will only accept Proposals that utilize PV technology combined with storage and include a CBRE portion as specified in Chapter 1. The CBRE portion must meet the CBRE Program and eligibility requirements identified in Part II of Rule 29 Community-Based Renewable Energy Program Phase 2 attached as Appendix J. Proposed projects must be located on the Site specified in Section 3.11. No other generation technologies or project locations may be proposed.
- 1.2.3 At least 40% of the 3 MW CBRE portion of the Project’s capacity must be reserved for residential Subscribers with unsubscribed RDG compensation subject to the requirements in Article 2 of the RDG PPA.

³ See <https://www.hawaiianelectric.com/clean-energy-hawaii/our-clean-energy-portfolio/renewable-project-status-board>

- 1.2.4 Preference will be given to Projects whose Subscriber portion reserves an amount greater than 40% of the CBRE portion of the Project capacity for residential customers and/or any additional amount of CBRE portion of the Project capacity dedicated to Low- and Moderate-Income Customers (“LMI”), as defined in Tariff Rule 29 in Appendix J.
- 1.2.5 Each Proposal submitted in response to this RFP must represent a Project that is capable of meeting the requirements of this RFP without having to rely on the completion or implementation of any other Project, or without having to rely on a proposed change in law, rule, or regulation.
- 1.2.6 Projects must interconnect to the Company’s System at the Miki Basin switchyard located on the Island of Lāna‘i (See Section 3.11 and Appendix F).
- 1.2.7 To prevent adverse impacts to a single point of failure of 2.5 MW the interconnection designs must limit single point of failure to no greater than 2.5 MW to meet this requirement. When dispatched by the Company, the Facility must be configured such that no single point of failure from the equipment will exceed 2.5 MW loss to the interconnection. Revisions will need to be made to the RDG PPA to account for multiple points of interconnection. The Company will provide such revisions upon completion of the Interconnection Requirements Study for the Final Award Group.
- 1.2.8 The contract for the project selected through this RFP shall use the RDG PPA, as described in Section 3.8. Under the RDG PPA, the Company will maintain exclusive rights to fully direct dispatch of the Facility, subject to availability of the resource and Section 1.2.9 below. The term of the PPA will be 20 years.
- 1.2.9 Proposals must be submitted with an energy storage component. The energy storage component can be charged during periods when full potential export of the generation Facility is not being dispatched by the Company and can be used to provide energy to the Company during other times that are beneficial to the system. The energy storage component must be able to store and discharge 70 percent of the PV produced energy, and continuously charge and discharge at a minimum of 10 MVA (8.5 MW at a 0.85 power factor) throughout the term of the PPA.
- 1.2.10 After the 5-year federal Investment Tax Credit (“ITC”) recapture period has lapsed, the energy storage component must be capable of being 100% charged from the grid at the direction of the Company. Energy storage components that are incapable of claiming the ITC must be capable of being 100% charged from the grid from the GCOD.
- 1.2.11 The maximum amount of energy discharged from the energy storage component in a year will be limited to 70 percent of the MWh target (or approximately 70 MWh) energy storage contract capacity multiplied by the number of Days in that year. An energy storage component may be dispatched more than once per Day, subject to such discharge energy limitations.
- 1.2.12 Proposals must specify a Guaranteed Commercial Operations Date (“GCOD”) no later than December 31, 2024. Preference will be given to Proposals that specify an earlier GCOD during the non-price evaluation.

- 1.2.13 A Proposer's GCOD set forth in its Proposal will be the GCOD in any resulting PPA if such Proposal is selected to the Final Award Group. Proposers will not be able to request a change in the GCOD set forth in their Proposals.
- 1.2.14 The selected Proposer will be responsible for all Project costs throughout the term of the PPA, including but not limited to Project development, completion of an Interconnection Requirements Study ("IRS"), the cost of conducting a greenhouse gas analysis, land leasing, permitting, financing, construction of the Facility and all Interconnection Facilities, and the operations and maintenance ("O&M") of the Facility.
- 1.2.15 The selected Proposer will be solely responsible for the decommissioning of the Project and the restoration of the Site upon the expiration of the PPA, as described in Attachment G, Section 7 of the RDG PPA.
- 1.2.16 The selected Proposer shall pursue all available applicable federal and state tax credits. Proposal pricing must be set to incorporate the benefit of such available federal tax credits. However, to mitigate the risk on Proposers due solely to potential changes to the state's tax credit law before a selected project reaches commercial operations, Proposal pricing shall be set without including any state tax credits. If a Proposal is selected, the PPA for the project will require the Proposer to pursue the maximum available state tax credit and remit tax credit proceeds to the Company for customers' benefit as described in Attachment J of the RDG PPA. The PPA will also provide that the Proposer will be responsible for payment of liquidated damages for failure to pursue the state tax credit.

1.3 Competitive Bidding Framework

Consistent with the Framework, this RFP outlines the Company's requirements in relation to the resources being solicited and the procedures for conducting the RFP process. It also includes information and instructions to prospective Proposers participating in and responding to this RFP.

1.4 Role of the Independent Observer

- 1.4.1 Part III.C.1 of the Framework sets forth the circumstances under which an Independent Observer is required in a competitive bidding process. The Independent Observer will advise and monitor all phases of the RFP process and will coordinate with PUC staff throughout the RFP process to ensure that the RFP is undertaken in a fair and unbiased manner. In particular, the Company will review and discuss with the Independent Observer decisions regarding the evaluation, disqualification, non-selection, and selection of Proposals.
- 1.4.2 The role of the Independent Observer, as described in the Framework, will include but is not limited to:
- Monitor all steps in the competitive bidding process
 - Monitor communications (and communications protocols) with Proposers
 - Monitor adherence to the Company's Code of Conduct
 - Submit comments and recommendations, if any, to the PUC concerning the RFP

- Review the Company’s Proposal evaluation methodology, models, criteria, and assumptions
- Review the Company’s evaluation of Proposals
- Advise the Company on its decision-making
- Participate in dispute resolution as set forth in Section 1.10
- Monitor contract negotiations with Proposers
- Report to the PUC on monitoring results during each stage of the competitive bidding process
- Provide an overall assessment of whether the goals of the RFP were achieved
- Monitor the ongoing discussions between Maui Electric and Pūlama Lāna‘i

1.4.3 The Independent Observers for this RFP is **Arroyo Seco Consulting**.

1.5 Communications Between the Company and Proposers – Code of Conduct Procedures Manual

1.5.1 Communications and other procedures under this RFP are governed by the “Code of Conduct Procedures Manual,” (also referred to as the “Procedures Manual”) developed by the Company as required by the Framework, and attached as Appendix C.

1.5.2 All pre-Proposal communication with prospective Proposers will be conducted via the Company’s RFP website, Electronic Procurement Platform, and/or electronic mail (“Email”) through the address specified in Section 1.6 (the “RFP Email Address”). Phone communication or face-to-face meetings will not be supported. Frequently asked questions submitted by prospective Proposers and the answers to those questions may be posted on the Company’s RFP website. The Company reserves the right to respond only to comments and questions it deems are appropriate and relevant to the RFP. Proposers shall submit questions no later than fifteen Days before the Proposal Due Date (see RFP Schedule in Section 3.1, Items 6 and 7). The Company will endeavor to respond to all questions no later than five Days before the Proposal Due Date.

1.5.3 After Proposals have been submitted, the Company may contact individual Proposers for purposes of clarifying their Proposal(s).

1.5.4 Any confidential information deemed by the Company, in its sole discretion, to be appropriate to share, will only be transmitted to the requesting party after receipt of a fully executed Mutual Confidentiality and Non-Disclosure Agreement⁴ (“NDA”). See Appendix E.

1.5.5 Except as expressly permitted and in the manner prescribed in the Procedures Manual, any unsolicited contact by a Proposer or prospective Proposer with personnel of the Company pertaining to this RFP is prohibited.

⁴ See Section 3.12.1 of this RFP.

1.6 Company Contact for Proposals

The primary contact for this RFP is:

Mery Apple
Energy Contract Manager
Hawaiian Electric Company, Inc.

RFP Email Address: cbrrfp@hawaiianelectric.com

1.7 Proposal Submission Requirements

- 1.7.1 All Proposals must be prepared and submitted in accordance with the procedures and format specified in the RFP. Proposers are required to respond to all questions and provide all information requested in the RFP, as applicable, and only via the communication methods specified in the RFP.
- 1.7.2 Detailed requirements regarding the form, submission, organization and information for the Proposal are set forth in Chapter 3 and Appendix B.
- 1.7.3 Proposals must not rely on any information that is not contained within the Proposal itself in demonstrating compliance for any requirement in this RFP.
- 1.7.4 In submitting a Proposal in response to this RFP, each Proposer certifies that the Proposal has been submitted in good faith and without fraud or collusion with any other unaffiliated person or entity. The Proposer shall acknowledge this in the Response Package submitted with its Proposal. Furthermore, in executing the NDA provided as Appendix E, the Proposer agrees on behalf of its Representatives (as defined in the NDA) that the Company's negotiating positions will not be shared with other Proposers or their respective Representatives.

In addition, in submitting a Proposal, a Proposer will be required to provide Company with its legal counsel's written certification in the form attached as Appendix B Attachment 1 certifying in relevant part that irrespective of any Proposer's direction, waiver, or request to the contrary, that the attorney will not share a Proposer's confidential information associated with such Proposer with others, including, but not limited to, such information such as a Proposer's or Company's negotiating positions. If legal counsel represents multiple unaffiliated Proposers whose Proposals are selected for the Final Award Group, such counsel will also be required to submit a similar certification at the conclusion of power purchase agreement negotiations that he or she has not shared a Proposer's confidential information or the Company's confidential information associated with such Proposer with others, including but not limited to, such information as a Proposer's or Company's negotiating positions.

- 1.7.5 All proposals must be submitted via the Electronic Procurement Platform by 2:00 pm Hawai'i Standard Time ("HST") on the Proposal Due Date shown in the RFP Schedule in Section 3.1. No hard copies of these Proposals will be accepted by the Company.⁵

It is the Proposer's sole responsibility to ensure that complete and accurate information has been submitted on time and consistent with the instructions of this RFP. With this assurance, Company shall be entitled to rely upon the completeness and accuracy of every Proposal. Any errors identified by the Proposer or Company after the Proposal Due Date has passed may jeopardize further consideration and success of the Proposal. If an error or errors are later identified, Company, in consultation with the Independent Observer, may permit the error(s) to be corrected without further revision to the Proposal, or may require Proposer to adhere to terms of the Proposal as submitted without correction. Additionally, and in Company's sole discretion, if such error(s) would materially affect the Final Award Group, Company reserves the right, in consultation with the Independent Observer, to remove or disqualify a Proposal upon discovery of the material error(s). The Proposer of such Proposal shall bear the full responsibility for such error(s) and shall have no recourse against Company's decision to address Proposal error(s), including removal or disqualification. The Energy Contract Manager, in consultation with the Independent Observer, will confirm that the Self-Build Proposal is submitted by the Self-Build Proposal Due Date in Section 3.1, Table 1, Item 6. The Electronic Procurement Platform automatically closes to further submissions after the IPP and Affiliate Proposal Due Date in Section 3.1, Table 1, Item 7.

1.8 Proposal Fee

- 1.8.1 IPP and Affiliate proposers are required to tender a non-refundable Proposal Fee of \$5,000 for each Proposal submitted.
- 1.8.2 The Proposal Fee must be in the form of a cashier's check or equivalent from a U.S.-chartered bank made payable to "Maui Electric Company, Ltd." and must be delivered and received by the Company by 2:00 pm HST on the Proposal Due Date shown in the RFP Schedule in Section 3.1. The cashier's check should include a reference to the Proposal(s) for which the Proposal Fee is being provided. Proposers are strongly encouraged to utilize a delivery service method that provides proof of delivery to validate delivery date and time.

If the Proposal Fee is delivered by U.S. Postal Service (with registered, certified, receipt verification), the Proposer shall address it to:

Mery Apple
Energy Contract Manager
Hawaiian Electric Company, Inc.
Mail Code CP21-IU
PO Box 2750
Honolulu, Hawai'i 96840

⁵ A Proposal for the SBO has additional submission requirements to the PUC specified in Section 1.9 below.

If the Proposal Fee is delivered by other courier services, the Proposer shall address it to:

Hawaiian Electric Company, Inc
Ward Receiving
Attention: Mery Apple, Energy Contract Manager
Mail Code CP21-IU
799 S. King St.
Honolulu, Hawai'i 96813

Due to COVID-19 disease prevention measures, Proposal Fees cannot be delivered in person.

1.9 Procedures for the Self-Build or Affiliate Proposals

- 1.9.1 Order No. 37070 states that the CBRE RFPs will be open to all bidders, including the Company. The Competitive Bidding Framework allows the Company the option to offer a Proposal(s) in response to this RFP (“Self-Build Option” or “SBO”). Accordingly, the Company must follow certain requirements and procedures designed to safeguard against and address concerns associated with: (1) preferential treatment of the SBO or members, agents, or consultants of the Company formulating the SBO (the “Self-Build Team”); and (2) preferential access to proprietary information by the Self-Build Team. These requirements are specified in the Code of Conduct (“CBRE Code of Conduct”) required under the Framework and implemented by certain rules and procedures found in the Procedures Manual submitted to the PUC in Docket No. 2015-0389 on July 9, 2020. The CBRE Code of Conduct will apply to all CBRE Phase 2 RFPs, regardless of whether the Company will submit an SBO Proposal. A copy of the Procedures Manual is attached as Appendix C.

The Competitive Bidding Framework also allows Affiliates of the Company to submit Proposals⁶ to RFPs issued by the Company. All Self-Build and Affiliate Proposals are subject to the Company’s Code of Conduct and the Procedures Manual. Affiliate Proposals are also subject to any applicable Affiliate Transaction Requirements issued by the PUC in Decision and Order No. 35962 on December 19, 2018, and subsequently modified by Order No. 36112, issued on January 24, 2019, in Docket No. 2018-0065. Affiliate Proposals will be treated identically to an IPP Proposal and must be submitted electronically through the Electronic Procurement Platform by IPP and Affiliate Proposal Due Date in RFP Table 1, Item 7.

- 1.9.2 The Company will require that the Proposal for the SBO(s) and Affiliate Proposals be submitted electronically through the Electronic Procurement Platform. SBO Proposals will be due a minimum of one (1) Day before other Proposals are due. A Proposal for the SBO will be uploaded into the Electronic Procurement Platform in the same manner Proposals from other Proposers are uploaded. The Energy Contract Manager, in consultation with the Independent Observer, will confirm that the Self-Build Proposals are timestamped by Milestone (6) Self-Build Proposal Due Date in RFP Table 1.

⁶ A Proposal will also be treated as an Affiliate Proposal if the Affiliate is a partner for the Proposal.

1.9.3 Detailed requirements for an SBO Proposal can be found in Appendix G. These requirements are intended to provide a level playing field between SBO Proposals and third-party Proposals. Except where specifically noted, an SBO Proposal must adhere to the same price and non-price Proposal requirements as required of all Proposers, as well as certain PPA requirements, such as milestones and liquidated damages, as described in Appendix G. The non-negotiability of the Performance Standards shall apply to any SBO to the same extent it would for any other Proposal. Notwithstanding the fact that it will not be required to enter into an RDG PPA with the Company, a Self-Build Proposer will be required to note its exceptions, if any, to the RDG PPA in the same manner required of other Proposers, and will be held to such modified parameters if selected. In addition to its Proposal, the Self-Build Team will be required to submit Appendix G Attachment 1, Self-Build Option Team Certification Form, acknowledging it has followed the rules and requirements of the RFP to the best of its ability and has not engaged in any collusive actions or received any preferential treatment or information providing an impermissible competitive advantage to the Self-Build Team over other proposers responding to this RFP, as well as adherence to PPA terms and milestones required of all proposers and the SBO's proposed cost protection measures.

The cost recovery methods between a regulated utility SBO Proposal and IPP Proposals are fundamentally different due to the business environments they operate in. As a result, the Company has instituted a process to compare the two types of proposals for the evaluation of the price related criteria on a 'like' basis through comparative analysis.

At the core of an SBO Proposal are its total project capital cost and any associated annual operations and maintenance ("O&M") costs. During the RFP's pricing evaluation step, these capital costs⁷ and O&M costs will be used in a revenue requirement calculation to determine the estimated revenues needed from customers which would allow the Company to recover the total cost of the project. The SBO revenue requirements are then used in a levelized price calculation to determine a Levelized Benefit ("LB") (\$/MWh) which will then be used for comparison to IPP Proposals.

The Company, in conjunction with the Independent Observer, may also conduct a risk assessment of the SBO Proposal to ensure an appropriate level of customer cost protection measures are included in such Proposal.

The SBO will be permitted to submit a shared savings mechanism with its Proposal to share in any cost savings between the amount of cost bid in the SBO Proposal and the actual cost to construct the Project. If the SBO Proposal is selected to the Final Award Group, the proposed shared savings mechanism will need to be approved by the PUC. Submission of a shared savings mechanism is not required and will not be considered in the evaluation of the SBO Proposal.

⁷ SBO Proposals will be required to provide a table identifying project costs by year. These capital costs should be all inclusive, including but not limited to costs associated with equipment, Engineering, Procurement, and Construction ("EPC"), interconnection, overhead, and Allowance for Funds Used During Construction ("AFUDC").

1.10 Dispute Resolution Process

- 1.10.1 If disputes arise under the RFP, the provisions of Section 1.10 and the dispute resolution process established in the Framework will control. See Part V of the Framework.
- 1.10.2 Proposers who challenge or contest any aspect of the RFP process must first attempt to resolve their concerns with the Company and the Independent Observer (“Initial Meeting”). The Independent Observer will seek to work cooperatively with the parties to resolve any disputes or pending issues and may offer to mediate the Initial Meeting to resolve disputes prior to such issues being presented to the PUC.
- 1.10.3 Any and all disputes arising out of or relating to the RFP which remain unresolved for a period of twenty (20) Days after the Initial Meeting takes place may, upon the agreement of the Proposer and the Company, be submitted to confidential mediation in Honolulu, Hawai‘i, pursuant to and in accordance with the Mediation Rules, Procedures, and Protocols of Dispute Prevention Resolution, Inc. (“DPR”) (or its successor) or, in its absence, the American Arbitration Association then in effect (“Mediation”). The Mediation will be administered by DPR. If the parties agree to submit the dispute to Mediation, the Proposer and the Company shall each pay fifty percent (50%) of the cost of the Mediation (i.e., the fees and expenses charged by the mediator and DPR) and shall otherwise each bear their own Mediation costs and attorneys’ fees.
- 1.10.4 If settlement of the dispute is not reached within sixty (60) Days after commencement of the Mediation, or if after the Initial Meeting, the parties do not agree to submit any unresolved disputes to Mediation, then as provided in the Framework, the Proposer may submit the dispute to the PUC in accordance with the Framework.
- 1.10.5 In accordance with the Framework, the PUC will serve as the arbiter of last resort for any disputes relating to this RFP involving Proposers. The PUC will use an informal expedited dispute resolution process to resolve the dispute within thirty (30) Days, as described in Parts III.B.8 and V of the Framework.⁸ There will be no right to hearing or appeal from this informal expedited dispute resolution process.
- 1.10.6 If any Proposer initiates a dispute resolution process for any dispute or claim arising under or relating to this RFP, other than that permitted by the Framework and this Section 1.10 (e.g., a court proceeding), then such Proposer shall be responsible for any and all attorneys’ fees and costs that may be incurred by the Company or the PUC in order to resolve such claim.

⁸ The informal expedited dispute resolution process does not apply to PUC review of contracts that result from the RFP. See Decision and Order No. 23121 at 34-35. Further, the informal expedited dispute resolution process does not apply to the Framework’s process relating to issuance of a draft and final RFP, and/or to the PUC approval of the RFP because: (1) the Framework (and the RFP) set forth specific processes whereby interested parties may provide input through the submission of comments; and (2) the Framework’s dispute resolution process applies to “Bidders” and there are no “Bidders” at this stage in the RFP process.

1.11 No Protest or Appeal

Subject to Section 1.10, no Proposer or other person will have the right to protest or appeal any award or disqualification of a Project made by the Company.

By submitting a Proposal in response to the RFP, the Proposer expressly agrees to the terms and conditions set forth in this RFP.

1.12 Modification or Cancellation of the Solicitation Process

1.12.1 Unless otherwise expressly prohibited, the Company may, at any time up to the final execution of an RDG PPA, as may be applicable, in consultation with the Independent Observer, postpone, withdraw, and/or cancel any requirement, term, or condition of this RFP, including deferral of the award or negotiation of any contract, and/or cancellation of the award all together, all of which will be without any liability to the Company.

1.12.2 The Company may modify this RFP subject to requirements of the Framework, whereby the modified RFP will be reviewed by the Independent Observer and submitted to the PUC thirty (30) Days prior to its issuance, unless the PUC directs otherwise. See Framework Part IV.B.10. The Company will follow the same procedure with regard to any potential postponement, withdrawal, or cancellation of the RFP or any portion thereof.

1.13 Community Outreach

The Company held a community meeting on Lāna‘i to explain the RFP process and the Company’s intent to procure a PV with storage project on the island of Lāna‘i. At the community meeting, the Company solicited feedback from the community of Lāna‘i regarding the RFP process and planned procurement. The Company has provided the comments received at the meeting in Appendix K. Proposers are encouraged to review such comments and take such comments into account when developing Proposals in response to this RFP.

Chapter 2: Resource Needs and Requirements

2.1 Performance Standards

Proposals must meet the attributes set forth in this RFP, Rule 29, and the requirements of the RDG PPA. This RFP, Rule 29, and the RDG PPA set forth the minimum requirements that all Proposals must satisfy to be eligible for consideration in this RFP. Additional Performance Standards may be required based on the results of the IRS.

Facilities must be able to operate in grid-forming mode as defined in the RDG PPA. The ability to startup without requiring energy from the grid (Black start capability) is required including energization of the interconnection transformers. The facility may be also utilized as the cranking path for island system restoration, based upon energy availability and storage state of charge.

The functionality and characteristics of the storage must be maintained throughout the term of the PPA. To be clear, Proposers may not propose any degradation for either capacity or efficiency in their Proposals.

2.2 Distribution-Level System Information

The Company has performed a preliminary evaluation of the Distribution System which indicates that a PV project of the requested size is able to be supported at the Miki Basin switchyard. A detailed IRS will be required to assess whether additional system mitigation measures will be required to integrate any specific project selected through this RFP. Per [Section 3.11](#) and [Appendix F](#), projects must interconnect to the Miki Basin switchyard. The estimated configuration of the interconnection is provided in [Appendix H](#). Any questions regarding the interconnection may be directed to the RFP Email Address in [Section 1.6](#).

2.3 Interconnection to the Company System

- 2.3.1 The Proposer must provide all information pertaining to the design, development, and construction of the Interconnection Facilities as specified in [Appendix B](#). Interconnection Facilities include both: (1) Seller-Owned Interconnection Facilities; and (2) Company-Owned Interconnection Facilities.
- 2.3.2 All Proposals must include a description and conceptual or schematic diagrams of the Proposer's plan to transmit power from the Facility to the Company System. The proposed Interconnection Facilities must be compatible with the Company System. In the design, Projects must adequately consider Company requirements to address impacts on the performance and reliability of the Company System.
- 2.3.2.1 In addition to the Performance Standards and findings of the IRS, the design of the Interconnection Facilities, including power rating, Point(s) of Interconnection with the Company System, and scheme of interconnection, must meet Company standards. The Company will provide its construction standards and procedures to the Proposer (Engineer, Procure, Construct Specifications for Hawaiian Electric Power Lines and Substations) if requested via the communication methods identified in [Section 1.5](#) and upon the execution of an NDA as specified in [Section 3.12.1](#). These specifications are intended to illustrate the scope of work typically required to administer and perform the design and construction of a Maui Electric substation and power line.
- 2.3.2.2 Interconnection Facilities must be designed such that it meets or exceeds the applicable single line diagram in [Appendix H](#), Attachment 1.
- 2.3.3 Tariff Rule No. 19, a copy of which is attached as [Appendix I](#), establishes provisions for Interconnection and Transmission Upgrades. While the Lānaʻi System does not have a traditional Transmission System, the tariff provisions are intended to simplify the rules regarding who pays for, installs, owns, and operates interconnection facilities in the context of competitive bidding. Proposers will be required to build the Company-Owned Interconnection Facilities, including any potential line extensions, except for any work in the Company's existing energized facilities and the final tap. Construction of Company-

Owned Interconnection Facilities by the Proposer must comply with industry standards, laws, rules, and licensing requirements, as well as the Company's specific construction standards and procedures that the Company will provide upon request. (See Section 2.3.2.1) Attachment A of Appendix I is provided to illustrate certain defined terms in Appendix I and does not represent the Company's design requirements. The design of all Interconnection Facilities will be subject to the requirements outlined in Section 2.3.2.1.

- 2.3.4 The Proposer shall be responsible for all costs required to interconnect a Project to the Company System, including but not limited to any work in the Company's existing energized facilities, the final tap, and all Seller-Owned Interconnection Facilities and Company-Owned Interconnection Facilities.
- 2.3.5 Proposers are required to include in their pricing proposal all costs for interconnection and distribution equipment expected to be required between their Facility and their proposed Point of Interconnection. Appendix H includes some information related to Company-Owned Interconnection Facilities and costs that may be helpful to Proposers. The selected Proposer shall be responsible for the actual final costs of all Seller-Owned Interconnection Facilities and Company-Owned Interconnection Facilities (see Appendix H, Attachment 1), whether or not such costs exceed the costs set forth in a Proposer's Proposal. No adjustments will be allowed to the proposed price in a Proposal if actual costs for Interconnection Facilities exceed the amounts proposed.
- 2.3.6 Proposers are required to include in their pricing proposal all costs for distribution-level service interconnection for station power.
- 2.3.7 All Projects will be screened for general readiness to comply with the requirements for interconnection. The selected Proposal will be subject to further study in the form of an IRS. The IRS process is further described in Section 5.1. The results of the completed IRS, as well as any mitigation measures identified, will be incorporated into the terms and conditions of a final executed PPA.

Chapter 3: Instructions to Proposers

3.1 Schedule for the Proposal Process

Table 1 sets forth the proposed schedule for the proposal process (the "RFP Schedule"). The RFP Schedule is subject to PUC approval. The Company reserves the right to revise the RFP Schedule as necessary. Changes to the RFP Schedule prior to the RFP Proposal Due Date will be posted to the RFP website. Changes to the RFP Schedule after the Proposal Due Date will be communicated via email to the Proposers and posted on the RFP Website.

**Table 1
RFP Schedule**

Milestone	Schedule Dates
(1) Draft RFP filed	July 9, 2020
(2) Technical Status Conference	July 29, 2020
(3) Parties and Participants file Comments by	August 12, 2020
(4) Proposed Final RFP filed	September 8, 2020
(5) Final RFP is Issued	October 20, 2020 ⁹
(6) Self-Build Proposal Due Date	December 21, 2020 at 2:00 pm HST
(7) IPP and Affiliate Proposal Due Date	December 22, 2020 at 2:00 pm HST
(8) Selection of Final Award Group	March 5, 2021
(9) Contract Negotiations Start	March 12, 2021

3.2 Company RFP Website/Electronic Procurement Platform

3.2.1 The Company has established a website for general information to share with potential Proposers. The RFP website is located at the following link:

<https://www.hawaiianelectric.com/clean-energy-hawaii/selling-power-to-the-utility/competitive-bidding-for-new-generation/lanai-rfp>

The Company will provide general notices, updates, schedules and other information on the RFP website throughout the process. Proposers should check the website frequently to stay abreast of any new developments. This website will also contain the link to the Electronic Procurement Platform employed by the Company for the receipt of Proposals.

“Sourcing Intelligence” developed by Power Advocate is the Electronic Procurement Platform that the Company has licensed and will utilize for the receipt of Proposals in this RFP. Proposers who do not already have an existing account with PowerAdvocate and who intend to submit a Proposal for this RFP will need to register as a “Supplier” with PowerAdvocate.

3.2.2 There are no license fees, costs, or usage fees to Proposers for the use of the Electronic Procurement Platform.

See Appendix D for user information on and screenshots of PowerAdvocate’s Sourcing Intelligence procurement platform.

⁹ Per Section IV.B.6.e.ii of the Competitive Bidding Framework “[t]he utility shall have the right to issue the RFP if the Commission does not direct the utility to do otherwise within thirty (30) days after the Commission receives the proposed RFP and the Independent Observer’s comments and recommendations.” October 20, 2020 assumes the Company issues a Final RFP to comply with Commission guidance received after 30 days. The Final RFP may be issued sooner, but the Company will not issue the Final RFP without Commission guidance.

3.3 Information Exchange

The PUC has conducted a Technical Status Conference on July 29, 2020 to discuss this draft RFP. Parties and Participants had the opportunity to submit comments on the draft RFP. The Company then revised the RFP after considering comments received and filed a final RFP for PUC review and approval.

Additionally, the Company will hold a prerecorded webinar for CBRE in accordance with the Competitive Bidding Framework for prospective Proposers to learn about the provisions and requirements of this RFP. This prerecorded webinar will be posted to the Company's website within one week of the issuance of the final RFP. Prospective Proposers may also submit written questions regarding the RFP to the RFP Email Address set forth in Section 1.6. The Company will endeavor to address all questions that will be helpful to prospective Proposers via a Q&A section on the RFP website.

Prospective Proposers should review the RFP Website's Q&A section prior to submission of their Proposal. Duplicate questions will not be answered.

3.4 Preparation of Proposals

- 3.4.1 Each Proposer shall be solely responsible for reviewing the RFP (including all attachments and links) and for thoroughly investigating and informing itself with respect to all matters pertinent to this RFP, the Proposer's Proposal, and the Proposer's anticipated performance under the RDG PPA. It is the Proposer's responsibility to ensure it understands all requirements of the RFP, to seek clarification if the RFP's requirements or Company's request is not clear, and to ask for any confirmation of receipt of submission of information. Under Section 1.7.5, the Proposer is solely responsible for all errors in its Proposal(s). The Company will not accept any assertion by a Proposer that it was incumbent on the Company to catch any error.
- 3.4.2 Proposers shall rely only on official information provided by the Company in this RFP when preparing their Proposal. The Company will rely only on the information included in the Proposals and additional information solicited by the Company to Proposers in the format requested, to evaluate the Proposals received. Evaluation will be based on the stated information in this RFP and on information submitted by Proposers in response to this RFP. Proposals must clearly state all capabilities, functionality and characteristics of the Project; must clearly detail plans to be performed; must explain applicability of information; and must provide all referenced material if it is to be considered during the Proposal evaluation. Referencing previous RFP submissions or projects for support will not be considered. Proposers should not assume that any previous RFP decisions or preferences also apply to this RFP.
- 3.4.3 Each Proposer shall be solely responsible for, and shall bear all of its costs incurred in the preparation of its Proposal and/or its participation in this RFP, including, but not limited to, all costs incurred with respect to the following: (1) review of the RFP documents; (2) status conference participation; (3) Site visits; (4) third-party consultant consultation; and

(5) investigation and research relating to its Proposal and this RFP. The Company will not reimburse any Proposer for any such costs, including the selected Proposer.

3.4.4 Each Proposal must contain the full name and business address of the Proposer and must be signed by an authorized officer or agent¹⁰ of the Proposer.

3.5 Organization of the Proposal

3.5.1 The Proposal must be organized as specified in Appendix B. It is the Proposer's responsibility to ensure the information requested in this RFP is submitted and contained within the defined Proposal sections as specified in Appendix B.

3.6 Proposal Limitations

Proposers expressly acknowledge that Proposals are submitted subject to the following limitations:

The RFP does not commit or require the Company to award a contract, pay any costs incurred by a Proposer in the preparation of a Proposal, or procure or contract for products or services of any kind whatsoever. The Company reserves the right, in consultation with the Independent Observer, to accept or reject, in whole or in part, any or all Proposals submitted in response to this RFP, to negotiate with any or all Proposers eligible to be selected for award, or to withdraw or modify this RFP in whole or in part at any time.

- The Company reserves the right, in consultation with the Independent Observer, to request additional information from any or all Proposers relating to their Proposals or to request that Proposers clarify the contents of their Proposals. Proposers who are not responsive to such information requests may be eliminated from further consideration upon consultation with the Independent Observer.
- The Company reserves the right, in consultation with the Independent Observer, to solicit additional Proposals from Proposers after reviewing the initial Proposals. Other than as provided in this RFP, no Proposer will be allowed to alter its Proposal or add new information to a Proposal after the Proposal Due Date.
- All material submitted in response to this RFP will become the sole property of the Company, subject to the terms of the NDA.

3.7 Proposal Compliance and Bases for Disqualification

Proposers may be deemed non-responsive and/or Proposals may not be considered for reasons including, but not limited to, the following:

¹⁰ Proposer's officer or agent must be authorized to sign the Proposal. Such authorization must be in writing and may be granted via Proposer's organizational documents (i.e., Articles of Incorporation, Articles of Organization, By-laws, etc.), resolution, or similar documentation.

- Any unsolicited contact by a Proposer or prospective Proposer with personnel of the Company pertaining to this RFP as described in Section 1.5.5.
- Any illegal or undue attempts by or on behalf of the Proposer or others to influence the Proposal Review process.
- The Proposal does not meet one or more of the Eligibility Requirements specified in Section 4.2.
- The Proposal does not meet one or more of the Threshold Requirements specified in Section 4.3.
- The Proposal is deemed to be unacceptable through a fatal flaws analysis as described in Section 4.4.2.
- The Proposer does not respond to a Company request for additional information to clarify the contents of its Proposal within the timelines specified by the Company.
- The Proposal contains misrepresentations or errors.

3.8 Power Purchase Agreement

- 3.8.1 The Power Purchase Agreement for proposals selected under this RFP will be in the form of the RDG PPA, attached as Appendix L.
- 3.8.2 If selected, any Affiliate Proposer will be required to enter into the RDG PPA with the Company.
- 3.8.3 If selected, a Self-Build Proposer will not be required to enter into a PPA with the Company. However, the Self-Build Proposer will be held to the proposed modifications to the RDG PPA, if any, it submits as part of the SBO in accordance with Section 3.8.5. Moreover, the SBO will be held to the same performance metrics and milestones set forth in the RDG PPA to the same extent as all Proposers, as attested to in the SBO's Appendix G, Attachment 1, Self-Build Option Certification submittal. If liquidated damages are assessed, they will be paid from shareholder funds and returned to customers through the Purchased Power Adjustment Clause ("PPAC") or other appropriate rate adjustment mechanisms.

To retain the benefits of operational flexibility of a Company-owned facility, the SBO Proposal will be permitted to adjust operational requirements and performance metrics with the approval of the PUC. The process for adjustment would be similar to a negotiated amendment to a PPA with PUC approval.

- 3.8.4 In general, under the RDG PPA, payment to the Seller consists of a Lump Sum Payment component to cover the costs of the Project. In return, the Seller shall guarantee minimum performance and availability metrics to ensure that the Facility is maintained and available for energy storage and dispatch, as well as provide an indication of the

available energy in near real-time for the Company's dispatch. Company shall not be obligated to accept, nor shall it be required to pay for, test energy generated by the Facility during acceptance testing or other test conditions.

- 3.8.5 The Performance Standards identified in Section 2.1 in the RDG PPA establish the minimum requirements a Proposal must satisfy to be eligible for consideration in this RFP. A proposed Facility's ability to meet these Performance Standards is both a Threshold Requirement and a Non-Price Related Criteria under Sections 4.3 and 4.4.2, respectively. As such, these Performance Standards included in the RDG PPA are non-negotiable. Proposers may propose modifications to other sections of the RDG PPA but are encouraged to accept such terms as written in order to expedite the overall RFP process and potential contract negotiations. As a component of their Proposals, Proposers who elect to propose modifications shall provide a Microsoft Word red-line version of the relevant document identifying specific proposed modifications to the model language that the Proposer is agreeable to, as well as a detailed explanation and supporting rationale for each modification.
- 3.8.5.1 General comments, drafting notes and footnotes such as "parties to discuss", and reservation of rights to propose modifications at a later time are unacceptable and will be considered non-responsive. Proposed modifications to the RDG PPA will be evaluated as a non-price evaluation criterion as further described in Section 4.4.2. In order to facilitate this process, the Company will make available an electronic version of the model agreement on the RFP website and through the Electronic Procurement Platform for the RFP. Any proposed modifications to the RDG PPA will be subject to negotiation between the Company and the Final Award Group and should not be assumed to have been accepted either as a result of being selected to the Final Award Group or based on any previously executed PPA. As stated above, since general comments, drafting notes, and footnotes without accompanying specific proposed language modifications are unacceptable and non-responsive, the Company will not negotiate provisions simply marked by such general comments, drafting notes, and footnotes.
- 3.8.5.2 The Company has an interest in maintaining consistency for certain provisions of the RDG PPAs, such as the calculation of availability and payment terms. Therefore, for such provisions, the Company will endeavor to negotiate similar and consistent language across PPAs for the Final Award Group.
- 3.8.6 Proposals that do not include specific proposed modifications to the attached RDG PPA will be deemed to have accepted the RDG PPA in its entirety.

3.9 Pricing Requirements

- 3.9.1 Proposers are responsible for understanding the terms of the RDG PPA. Pricing cannot be specified as contingent upon other factors (e.g., changes to federal tax policy or receiving all Investment Tax Credits assumed).
- 3.9.2 Escalation in pricing over the term of the RDG PPA is prohibited.

3.9.3 Pricing information must only be identified within specified sections of the Proposal instructed by this RFP's Appendix B Proposer's Response Package (i.e., Proposal pricing information must be contained within defined Proposal sections of the Proposal submission). Pricing information contained anywhere else in a Proposal will not be considered during the evaluation process.

3.9.4 The Proposer's Response Package must include the following prices for each Proposal:

For IPP or Affiliate proposals:

- **Lump Sum Payment (\$/year):** Payment amount for full dispatchability of the Facility. Payment will be made in monthly increments.

For the Self-Build Proposal:

- **Total Project Capital Costs (\$/year):** Total capital costs for the project (identified by year).
- **Annual O&M Costs (\$/year):** Initial year operations and maintenance costs, annual escalation rate.
- **Annual Revenue Requirement (\$/year):** Annual revenue requirements (ARR) calculated for each year.

Additional description and detail on the Total Project Capital Costs, Annual O&M Costs, and Annual Revenue Requirement for the SBO Proposal is located in Appendix G.

3.9.5 As identified in the Schedule of Defined Terms in the PPA under "BESS Allocated Portion of the Lump Sum Payment", the allocated portion of the Lump Sum Payment specified for energy storage for the Facility is 50% and shall be a non-negotiable percentage in the PPA.

3.10 Project Description

3.10.1 Proposals are required to provide a Net Energy Potential ("NEP") RFP Projection for the Project. The NEP RFP Projection associated with the proposed Project represents the estimated annual net energy (in MWh) that could be produced by the Facility and delivered to the Point of Interconnection over a ten-year period with a probability of exceedance of 95%. The energy generated by the Facility in excess of Company Dispatch but below the Facility's Allowed Capacity that is stored in the Facility's energy storage component and can later be discharged to the POI considering the BESS Contract Capacity and Maximum Rated Output should be included in the NEP RFP Projection. Any energy in excess of what is allowed to be delivered to the POI and would exceed the BESS Contract Capacity shall be excluded from the Net Energy Potential. Any energy generated outside of the proposed Facility that is used to charge the energy storage component should not be factored into the NEP RFP Projection. Any losses that may be

incurred from energy being stored and then discharged from the energy storage (round trip efficiency losses) should be excluded from the NEP RFP Projection, but the NEP should consider auxiliary loads in developing the value relative to the POI. The NEP RFP Projection will be used in the RFP evaluation process and therefore Proposers will be held to their provided value.¹¹

- 3.10.2 Proposals are required to provide a single value Round Trip Efficiency (“RTE”), measured at the Point of Interconnection, that the Facility will maintain throughout the term of the PPA. This RTE value will be used in the RFP evaluation process and therefore Proposers will be held to this provided value. The RTE is specified in Appendix B Section 2.
- 3.10.3 Each Proposer must also agree to provide Project financial information, including proposed Project finance structure information specified in Appendix B. Such information will be used to evaluate Threshold Requirements and non-price criteria (e.g., Financial Viability of Proposer, Financial Strength and Financing Plan, State of Project Development and Schedule) set forth in Sections 4.3 and 4.4.2. Upon selection, the Final Award Group may be requested to provide further detailed cost information if requested by the PUC or the Consumer Advocate as part of the PPA approval process. If requested, such information would be provided to the PUC, Consumer Advocate, and Company pursuant to a protective order in the docket.
- 3.10.4 The Proposer agrees that no material changes or additions to the Facility from what is submitted in its Proposal will be made without the Proposer first having obtained prior written consent from the Company. Evaluation of all Proposals in this RFP is based on the information submitted in each Proposal at the Proposal Due Date. If any Proposer requests that any Proposal information be changed after that date, the Company, in consultation with the Independent Observer, and in consideration of whether the evaluation is affected, will determine whether the change is permitted.

3.11 Project Site

All proposals must be sited on a pre-determined Project Site owned by Pūlama Lāna‘i, referred to as the Pūlama Site.¹² The available area is approximately seventy-three (73) acres and is located adjacent to Miki Road and Miki Basin Plant, less than one (1) mile from the airport.

¹¹ If a PPA is executed between the Company and the selected Proposer, the NEP RFP Projection will be further evaluated at several steps throughout the process as set forth in the RDG PPA, and adjustments to the Lump Sum Payment will be made accordingly. Additionally, because the Company will rely on an accurate representation of the NEP RFP Projection in the RFP evaluation, a one-time liquidated damage as described in the RDG PPA will be assessed if the First NEP benchmark is less than the Proposer’s NEP RFP Projection. After the Facility has achieved commercial operations, the performance of the Facility will be assessed on a continuing basis against key metrics identified in the RDG PPA. See Article 2 and Attachment U of the RDG PPA.

¹² The location and acreage of the Pūlama Site in this RFP is different from the Pūlama Site identified in the RFP for Variable Renewable Dispatchable Generation Paired with Energy Storage, Island of Lāna‘i, dated November 27, 2019 and revised March 10, 2020.

The selected Proposer will be required to execute a lease for the Pūlama Site coterminous with the term of the PPA with the landowner. A draft copy of the proposed form of lease and lease term sheet are included as Attachment 2 and Attachment 3, respectively, to Appendix F. The terms of the lease will be negotiable with the landowner. Additional information regarding the site, including a link to an Environmental Assessment and associated studies can also be found in Appendix F.

Due to COVID-19 travel restrictions, a site visit will not be available at this time. The Company will endeavor to provide as much information as possible to interested potential Proposers. Additional site information, beyond the details included in Appendix F, may be provided by the Company. Information on how to request such additional information, if available, will be posted on the Company's website.

3.12 Confidentiality

- 3.12.1 Each prospective Proposer must submit an executed NDA in the form attached as Appendix E by the Proposal Due Date specified in the RFP Schedule in Section 3.1. If a Proposer had previously executed an NDA for the Request for Proposal for Variable Renewable Dispatchable Generation Paired with Energy Storage, Island of Lānaʻi, dated November 29, 2019, that executed NDA will be accepted. The form of the NDA is not negotiable. Information designated as confidential by the Company will be provided on a limited basis, and only those prospective Proposers who have submitted an executed NDA will be considered. Proposers must clearly identify all confidential information in their Proposals. However, Proposers should designate as confidential only those portions of their Proposals that genuinely warrant confidential treatment. The Company discourages the practice of marking every page of a Proposal as confidential. The Company will make reasonable efforts to protect any such information that is clearly marked as confidential. Consistent with the terms of the NDA, the Company reserves the right to share any information, even if marked confidential, with its agents, contractors, or the Independent Observer for the purpose of evaluating the Proposal and facilitating potential contract negotiations.
- 3.12.2 Proposers, in submitting any Proposal to Company in response to this RFP, certify that such Proposer has not shared its Proposal, or any part thereof, with any other Proposer of a Proposal responsive to this RFP.
- 3.12.3 The Company will request that the PUC issue a Protective Order to protect confidential information provided by Proposers to the Company and to be filed in a proceeding before the PUC. A copy of the Protective Order, once issued by the PUC, will be provided to Proposers. Proposers should be aware that the Company may be required to share certain confidential information contained in Proposals with the PUC, the State of Hawaiʻi Department of Commerce and Consumer Affairs, Division of Consumer Advocacy, and the parties to any docket instituted by the PUC, provided that recipients of confidential information have first agreed in writing to abide by the terms of the Protective Order. Notwithstanding the foregoing, no Proposer will be provided with Proposals from any

other Proposer, nor will Proposers be provided with any other information contained in such Proposals or provided by or with respect to any other Proposer.

3.13 Credit Requirements Under the PPA

- 3.13.1 The Proposer with whom the Company enters into a PPA must post Development Period Security and Operating Period Security in the form of an irrevocable standby letter of credit from a bank chartered in the United States as required and set forth in Article 14 of the RDG PPA.
- 3.13.2 The Development Period Security and Operating Period Security identified in the RDG PPA are minimum requirements. Proposers shall not propose an amount lower than that set forth in the RDG PPA.
- 3.13.3 Each Proposer shall be required to provide a satisfactory irrevocable standby letter of credit in favor of the Company from a bank chartered in the United States to guarantee Proposer's payment of interconnection costs for all Company-Owned Interconnection Facilities in excess of the Total Estimated Interconnection Costs and/or all relocation costs in excess of Total Estimated Relocation Costs that are payable to Company as required and set forth in Attachment G to the RDG PPA.
- 3.13.4 Proposers may be required to provide an irrevocable standby letter of credit in favor of the Company from a bank chartered in the United States in lieu of the required Source Code Escrow in an amount and as required and set forth in Attachment B to the RDG PPA.

Chapter 4: Evaluation Process and Evaluation Criteria

4.1 Proposal Evaluation and Selection Process

The Company will employ a multi-step evaluation process. Once the Proposals are received, the Proposals will be subject to a consistent and defined review, evaluation, and selection process. This Chapter provides a description of each step of the process, along with the requirements of Proposers at each step. Figure 1 sets forth the flowchart for the proposal evaluation and selection process.

Upon receipt of the Proposals, the Company will review each Proposal submission to determine if it meets the Eligibility Requirements and the Threshold Requirements. The Company, in coordination with the Independent Observer will determine if a Proposer is allowed to cure any aspect of its Proposal or whether the Proposal will be eliminated based on failure to meet either Eligibility or Threshold Requirements.¹³ If a Proposer is provided the opportunity to cure any aspect of its Proposal, the Proposer shall be given

¹³ As a general rule, if a Proposer does not include a requested document, inadvertently excludes minor information or provides inconsistencies in its information, it may be given a chance to cure such deficiency. If a Proposer fails to provide material required information in its Proposal and providing the Proposer an opportunity to cure is deemed by the Company, in consultation with the Independent Observer, as an unfair advantage to such Proposer, the Proposal could be classified as non-conforming and eliminated for failure to meet Eligibility Requirements.

three (3) business days to cure from the date of notification to cure¹⁴. Proposals that have successfully met the Eligibility and Threshold Requirements will then enter a price and non-price evaluation process, ultimately ending in a Proposal being selected to the Final Award Group.

¹⁴ The initial request will be offered 3 business days to cure. Succeeding inquiries on the deficiencies will be offered cure periods deemed sufficient by the Company and Independent Observer.

Figure 1 – Evaluation Workflow

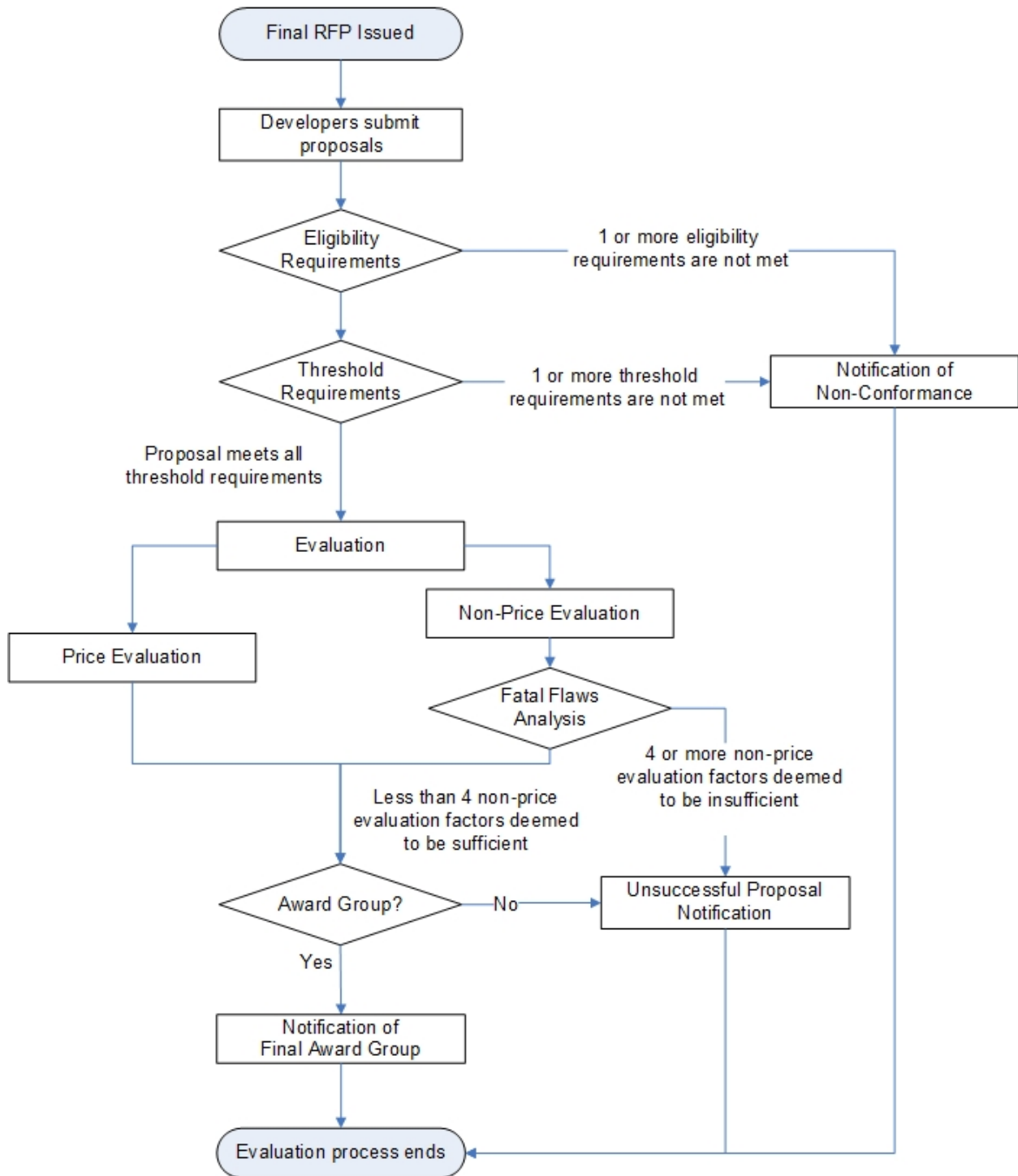

4.2 Eligibility Requirements Assessment

Upon receipt of the Proposals, each Proposal will be reviewed to ensure that it meets the following Eligibility Requirements.

- A Proposer is not eligible to participate in this RFP if the Proposer, its parent company, or an affiliate of the Proposer has:
 - defaulted on a current contract with the Company, or
 - had a contract terminated by the Company, or
 - any pending litigation with the Company.
- The Proposal, including required uploaded files, must be received on time via the Electronic Procurement Platform.
- The Proposal Fee must be received on time on or before the Proposal Due Date.¹⁵
- The Proposal must not contain material omissions.
- The Proposal must be signed and certified by an officer or other authorized agent of the Proposer.
- The Proposers must fully execute the NDA and any other documents required pursuant to this RFP.
- The Proposer must provide a Certificate of Vendor Compliance from the Hawai'i Compliance Express dated issued within 60 days of the date of Proposal submission (a certificate of good standing from the State of Hawai'i Department of Commerce and Consumer Affairs and also federal and Hawai'i state tax clearance certificates for the Proposer may be substituted for the Certificate of Vendor Compliance).
- The Proposal must not be contingent upon changes to existing county, state, or federal laws or regulations.
- The Proposal must be sited on the Pūlama Site.
- The Proposal must be for a PV project and must include an energy storage component.
- The largest contingency size shall be limited to 2.5MW net export at the Miki Basin switchyard. The design to achieve this must be acceptable to the Company.
- A minimum of 3 MW of the Project capacity must be dedicated to CBRE.
- A minimum of 40% of the CBRE portion of the Project must be dedicated to residential Subscribers as described in Section 1.2.3.
- The energy storage component must be able to be charged from the grid at the direction of the Company as described in Section 1.2.11.
- Proposals must provide grid-forming and black start capabilities as described in Section 2.1.
- Proposals must specify a GCOD no later than December 31, 2024.
- Proposers shall agree to post Development Period Security and Operating Period Security as described in Section 3.13.

¹⁵ Proposal Fees will not be required for the SBO Proposal.

4.3 Threshold Requirement Assessment

Proposals that meet all the Eligibility Requirements will then be evaluated to determine compliance with the Threshold Requirements, which have been designed to screen out Proposals that are insufficiently developed, lack demonstrated technology, or will impose unacceptable execution risk for the Company.

Proposals must provide explanations and contain supporting information demonstrating how and why the Project proposed meets each of the Threshold Requirements. Proposals that fail to provide this information or meet a Threshold Requirement will be eliminated from further consideration upon concurrence with the Independent Observer.

The Threshold Requirements for this RFP are the following:

1. **RESERVED**

2. **Performance Standards:** The proposed Facility must be able to meet the performance attributes identified in this RFP and the Performance Standards identified in Section 2.1 of this RFP. Proposals should include sufficient documentation to support the stated claim that the Facility will be able to meet the Performance Standards. The Proposal should include information required to make such a determination in an organized manner to ensure this evaluation can be completed within the evaluation review period.

3. **Proven Technology:** This criterion is intended as a check to ensure that the technology proposed is viable and can reasonably be relied upon to meet the objectives of this RFP. The Company will only consider Proposals utilizing technologies that have successfully reached commercial operations in commercial applications (i.e., a PPA) at the scale being proposed. Proposals should include any supporting information for the Company to assess the commercial and financial maturity of the technology being proposed.

4. **Experience of the Proposer:** The Proposer, its affiliated companies, partners, and/or contractors and consultants on the Proposer's Project team must have experience in financing, designing, constructing, interconnecting, owning, operating, and maintaining at least one (1) electricity generation project, including all components of the project (i.e., storage or other attributes), similar in size, scope, technology, and structure to the Project being proposed by Proposer. The Company will consider a Proposer to have reasonably met this Threshold Requirement if the Proposer can provide sufficient information in its Proposal's RFP Appendix B Section 2.13 tables demonstrating that at least one member of the Proposer's team (identified in the Proposal) has specific experience in each of the following categories: financing, designing, constructing, interconnecting, owning, operating, and maintaining projects similar to the Project being proposed.

5. **Financial Compliance:** The proposed Project must not cause the Company to be subject to consolidation, as set forth in Financial Accounting Standards Board ("FASB") Accounting Standards Codification Topic 810, Consolidation ("ASC 810"), as issued and amended from time to time by FASB. Proposers are required to state to the best of their

knowledge, with supporting information to allow the Company to verify such conclusion, that the Proposal will not result in the Seller under the PPA being a Variable Interest Entity (“VIE”) and result in the Company being the primary beneficiary of the Seller that would trigger consolidation of the Seller’s finances on to the Company’s financial statements under FASB ASC 810. The Company will perform a preliminary consolidation assessment based on the Proposals received. The Company reserves the right to allow a Proposal to proceed through the evaluation process through selection of the Priority List and work with the Proposer on this issue prior to or during PPA negotiations. The Company has determined that for purposes of FASB ASC 842, a generation plus storage facility will be treated as two separate measurements of account. For accounting purposes, the energy storage portion (if applicable) will be treated as a lease, while the generation facility will not. As a result, no lease evaluation will be completed as part of the Proposal evaluation.

6. Community Outreach: Gaining community support is an important part of a Project’s viability and success. A comprehensive community outreach and communications plan (“Community Outreach Plan”) is an essential roadmap that guides a developer as they work with various communities and stakeholders to gain their support for a Project. Proposers must include a Community Outreach Plan that describes the Proposer’s commitment to work with the neighboring community and stakeholders and to provide them timely Project information during all phases of the Project. The Community Outreach Plan shall include, but not be limited to, the following information: Project description, community scoping (including stakeholders and community concerns), Project benefits, government approvals, development process (including Project schedule), and a comprehensive communications plan.

7. RESERVED

4.4 Evaluation – Price and Non-Price Analysis

Proposals that meet both the Eligibility and Threshold Requirements are Eligible Proposals which will then be subject to a price and non-price assessment. Two teams have been established to undertake the Proposal evaluation process: a Price Evaluation Team and Non-Price Evaluation Team. The results of the price and non-price analysis will be a relative ranking and scoring of all Eligible Proposals. Price-related criteria will account for fifty-one percent (51%) of the total score and non-price-related criteria will account for forty-nine percent (49%) of the total score. The non-price criteria and methodology for applying the criteria are explained in Section 4.4.2.

The Company will employ a closed-bidding process for this solicitation in accordance with Part IV.H.3 of the Framework where the price and non-price evaluation models to be used will not be provided to Proposers. However, the Company will provide the Independent Observer with all necessary information to allow the Independent Observer to understand the evaluation models and to enable the Independent Observer to observe the entire analysis to ensure a fair process.

4.4.1 Evaluation of the Price Related Criteria

For the evaluation price analysis, an avoided cost screening approach will be used to rank proposals. Using the forecast and planning assumptions developed for the Company's Integrated Grid Planning process and evaluation methodology proposed in the Solution Evaluation & Optimization Working Group, a resource portfolio will be developed using a capacity expansion model to identify proxy resources that serve the grid needs and inform their marginal avoided costs. For each Proposal, the avoided cost of each grid service would be multiplied by the expected ability of the Proposal to provide that service or others, and summed across the services to determine the potential benefit of the Proposal. The benefit would then be reduced by the Proposal cost and normalized by the NEP provided in the Proposal to calculate a Levelized Benefit ("LB") (\$/MWh).

The Company will conduct the comparative evaluation and award evaluation points to Proposals in accordance with the relative ranking based on LB. The Eligible Proposal with the highest LB will receive 510 points. All other Eligible Proposals will receive points based on a proportionate reduction using the percentage by which the Eligible Proposal's LB is lower than the highest LB. For example, if a Proposal's LB is ten percent (10%) lower than the highest LB, the Proposal will be awarded 459 points (that is, 510 points less 10%). The result of this assessment will be a ranking and scoring of the Proposals.

4.4.2 Evaluation of the Non-Price Related Criteria

For the non-price analysis, each Proposal will be evaluated on each of the non-price criteria categories set forth below:

1. Community Outreach
2. State of Project Development and Schedule
3. Performance Standards
4. RESERVED
5. Commitment to Residential Subscriber Participation
6. CBRE Program
7. Environmental Compliance and Permitting Plan
8. Experience and Qualifications
9. Financial Strength and Financing Plan
10. RDG PPA Contract Exceptions
11. Guaranteed Commercial Operations Date
12. Cultural Resource Impacts

Criteria 1 through 6 (as applicable) – will be weighted twice as heavily as the others to reflect the impact these categories have to achieve a successful and timely procurement. The non-price criteria are generally scored on a scale of 1 (poor) to 5 (highly preferable). A score of 3 means that a Proposal meets the minimum standard for that criteria.

The total non-price score will be the sum of the scores for each of the applicable individual non-price criteria. The Company will then award non-price evaluation points

in accordance with the relative ranking of scores. The Proposal with the highest total non-price score will receive 490 points, and all other Proposals will receive points equal to the Proposal's score divided by the top score, multiplied by 490.

During the non-price criteria evaluation, a fatal flaws analysis will also be conducted such that any Proposal that is deemed not to meet the minimum standards level for four (4) or more applicable non-price criteria will be disqualified given that the Proposal has failed to meet a majority of non-price factors that are indicative as to the general feasibility and operational viability of a proposed Project. Non-price criteria number 5 and 11 above will be excluded from the fatal flaws analysis.

The Company's evaluation of the non-price criteria will be based on the materials provided by a Proposer in its Proposal. Acceptance of any Proposal into the Final Award Group shall not be assumed or construed to be an endorsement or approval that the materials provided by Proposer are complete, accurate or in compliance with applicable law. The Company assumes no obligation to correct, confirm or further research any of the materials submitted by Proposers. Proposers retain sole responsibility to ensure their Proposals are accurate and in compliance with all laws.

The non-price criteria are:

1. **Community Outreach** – Gaining community support is an important part of a Project's viability and success. An effective Community Outreach Plan will call for early meaningful communications with stakeholders and will reflect a deep understanding and respect for the community's desire for information to enable them to make informed decisions about future projects in their communities. Therefore, Proposals will be evaluated on the quality of the Community Outreach Plan to inform the Project's impacted communities.

Proposals should include a Community Outreach Plan that describes the Proposer's commitment to work with the neighboring community and stakeholders and to provide timely Project information during project development, construction and operation. The Community Outreach Plan shall include, but not be limited to the following:

- 1) Project description. A thorough description including a map of the location of the Project. This information will help the community understand the impact that the Project may have on the community.
- 2) Community scoping. Identify stakeholders (individuals, community leaders, organizations), community issues and concerns, and community sentiment.
- 3) Project benefits. An explanation of the need for the Project. This will help the community to understand how the Project might benefit their community.
- 4) Government approvals. Required government permits and approvals, public hearings and other opportunities for public comment. This information will help the community to understand the level of public scrutiny and participation that might occur for the Project and the opportunities to provide public comments.

- 5) Development process. A Project schedule that identifies key milestones will facilitate the community's understanding of the development process.
- 6) Communications Plan. A communications plan including a detailed community outreach schedule that will keep the affected communities and stakeholders informed about the Project's outreach efforts during early Project development period through construction and operations.

Preference will be given to Proposers who have already identified established contacts to work with the local community, have used community input to incorporate changes to the final design of the Project and mitigate community concerns, have proposed a community benefits package (including details of the community recipients and benefits package), or have community consultants as part of the Project team doing business in Hawai'i that have successfully worked with communities in Hawai'i on the development of two or more energy projects or projects with similar community issues. These criteria are aligned with the Company's community engagement expectation whereby all developers will be required to engage in community outreach prior to signing a PPA with the Company. This process is also outlined in RFP Section 5.3. Further information and instructions regarding expectations for the Community Outreach Plan are included as Attachment 4 and 5 to Appendix B.

2. **State of Project Development and Schedule** – Projects that are further along in development generally have lower project execution risk and a greater probability of being able to be successfully placed into service prior to the GCOD (specifically identified in each Proposal). At a minimum, Projects should demonstrate how they plan to capture any ITC safe harbor and reach their GCOD specified, including identification of risks and schedule assumptions. (Schedules must identify the IRS completion date and PUC approval dates assumed.) Proposals should also demonstrate, via a detailed critical path schedule, that there is a high likelihood that the Project will be able to reach commercial operations as specified. Proposals shall include a Gantt chart that clearly illustrates the overall schedule and demonstrates achievement of any ITC safe harbor, if applicable, and commercial operations by their specified GCOD. The Gantt chart shall include task durations and dependencies, identify tasks that will be fast tracked, and identifies slack time and contingencies. This criterion will also look at the high-level Project costs set forth in the Proposal including: costs for equipment, construction, engineering, Seller-Owned Interconnection Facilities, Company-Owned Interconnection Facilities, land, annual O&M, the reasonableness of such costs and the assumptions used for such costs. Project costs that do not appear reasonable for a project of the size proposed may result in a lower ranking for this criterion if the Company reasonably determines that the cost information is unrealistic based on prior experience in the market which may result in a risk that the Project can be built on time and for the price proposed by the Proposer. The Company reserves the right to discuss any cost and financial information with a Proposer to ensure the information provided is accurate and correct.

3. **Performance Standards:** The proposed Facility must be able to meet the performance attributes identified in this RFP and the Performance Standards identified in the RDG PPA. The Company will review the Proposal information received, including design documents and operating procedures materials provided in the Proposal, and evaluate whether the Project as designed is able to meet the Performance Standards identified in the RDG PPA or and in this RFP. At a minimum, in addition to meeting the Performance Standards, the Proposal should include sufficient documentation, provided in an organized manner, to support the stated claim that the Facility will be able to meet the Performance Standards. The Proposal should include information required to make such a determination in an organized manner to ensure this evaluation can be completed on a timely basis. Preference will be given to Proposals that provide detailed technical and design information showing how each standard can be met by the proposed Facility. Preference will also be provided on facilities that offer additional capabilities.
4. **RESERVED**
5. **Commitment to Residential Subscriber Participation** – Proposals will be evaluated on the planned commitments of the Project’s Subscriber Organization to encourage participation of residential Subscribers. At a minimum, Subscriber Organizations will be required to set aside 40% of the CBRE portion of the Project’s capacity for residential Subscribers. Proposers that commit to reserving a portion larger than 40% of the CBRE portion of their Project capacity for residential Subscribers will be given more favorable scoring. In addition, Proposals will also be evaluated on the planned commitments of the Project’s CBRE Subscriber Organization to encourage participation of LMI Customers. Proposers that commit to reserving a portion of the CBRE portion of the Project’s capacity for LMI Customers will be given more favorable scoring.
6. **CBRE Program:** Proposals will be evaluated on several facets of the CBRE program being proposed.
 - 1) **Program Offering:** Proposals will be evaluated to give preference to program offerings that provide the most benefits to residential and LMI Customers, as applicable. Financing options, upfront fees, payment over time, public funding options, and other creative approaches will be preferred along with programs that offer higher expected customer level savings, favorable payback periods and mechanisms, and other customer benefits. In addition, Proposals shall describe the extent to which residential Subscribers will be financially responsible for the Facility’s underperformance.
 - 2) **Marketing and Outreach Plans:** Proposals will be evaluated on the proposed strategies and methods to educate, inform, and stimulate the market in order to achieve their target levels of participation.
 - 3) **Program Experience:** Proposals will also be evaluated on Proposers documented success in reaching and retaining participation of residential and

LMI Customers, as applicable, in other community-based renewable energy programs.

- 7. Environmental Compliance and Permitting Plan** – This criterion relates to the potential (short- and long-term) environmental impacts associated with each project, the quality of the plan offered by the Proposer to mitigate and manage any environmental impacts (including any pre-existing environmental conditions), and the plan of Proposers to remain in environmental compliance over the term of the contract. These impacts are reflected on a technology-specific basis. Completing any necessary environmental review and obtaining the required permitting in a timely manner is also important and Proposals will be evaluated on their plan to identify, apply for, and secure the required permits for the Project, any permitting activity that has been completed to date, including having initial discussions with the applicable regulating agencies such as U.S. Fish and Wildlife and the State of Hawai‘i Department of Land and Natural Resources’ Division of Forestry and Wildlife, prior to submitting a Proposal, and the degree of certainty offered by the Proposer in securing the necessary permits.

At a minimum, proposed Projects should be expected to have minimal environmental impact for most areas and Proposals should provide a comprehensive plan to mitigate the identified potential or actual significant environmental impacts to remain in environmental compliance. The proposed mitigation plans should be included in the Project timeline. Preference will be given to Proposals that provide a more detailed plan as well as those that have proactively taken steps to mitigate potential environmental impacts.

Also, this criterion requires that, at a minimum, Proposers should have identified, and disclosed in their Proposal(s) all major permits, approvals, appurtenances and entitlements (including applicable access, rights of way and/or easements) (collectively, the “permits”) required and have a preliminary plan for securing such permits. Preference will be given to Proposals that are able to provide a greater degree of certainty that its plan to secure the required permits is realistic and achievable, or have already received all or a majority of the required permits. The Proposer should disclose all identified (a) discretionary permits required, i.e., those requiring public or contested case hearings and/or review and discretionary approval by an appropriate government agency and (b) ministerial conditions without discretionary approval conditions. In all cases, the Proposer must provide a credible and viable plan to secure all necessary and appropriate permits necessary for the project. For example, if the project is located within an agricultural district, the Proposer shall provide evidence of Proposer’s verification with the appropriate government agency that the project complies with HRS Section 205-2 and Section 205-4.5, relating to solar energy facilities placed on agricultural land, provided, however that where a special use permit (under Section 205-6), exemption (under Section 205-6), or amendment to land use district boundary lines (under Section 205-4) is required to secure such compliance, Proposer shall identify the need for such permit, exemption or amendment and provide a list of required prerequisites and/or conditions and a realistic timeline necessary to obtain such permit, exemption or amendment satisfactory for Proposer to still meet its designated Guaranteed Commercial Operations Date.

8. **Experience and Qualifications** – Proposals will be evaluated based on the experience of the Proposer in financing, designing, constructing, interconnecting, owning, operating, and maintaining projects (including all components of the project) of similar size, scope and technology. At a minimum, Proposals must show via the table format specified in RFP Appendix B Section 2.13 that at least one (1) member must have specific experience in each of the following categories: financing, designing, constructing, interconnecting, owning, operating, and maintaining at least one electricity generation project including all components of the project similar to the Project being proposed. Preference will be given to Proposers with experience in successfully developing multiple projects that are similar to the one being proposed and/or that have prior experience successfully developing and interconnecting a utility scale project to the Company's System.
9. **Financial Strength and Financing Plan** – This criterion addresses the comprehensiveness and reasonableness of the financial plan for the Project as well as assesses the financial strength and capability of the Proposer to develop the Project. A complete financial plan addresses the following issues: Project ownership, capital cost and capital structure, sources of debt and equity, and evidence that credit-worthy entities are interested in financing the Project. The financial strength of Proposers or their credit support providers will be considered, including their credit ratings. The financing participants are expected to be reasonably strong financially. Developers and their sources of capital that have investment grade credit ratings from a reputable credit rating agency (S&P, Moody's, Fitch) will also be given preference, with those that have higher credit ratings ranked higher.
10. **RDG PPA Contract Proposed Modifications** – Proposers are encouraged to accept the contract terms identified in the model PDG PPA in its entirety in order to expedite the overall RFP process and potential contract negotiations. Proposers who accept the model RDG PPA without edits, will receive a higher score and will be the only proposals that can achieve the highest scoring for this non-price evaluation criterion. Technology-specific or operating characteristic-required modifications, with adequate explanation as to the necessity of such modifications, will not jeopardize a project's ability to achieve the highest score. Proposers who elect to propose modifications to the model agreements shall provide a Microsoft Word red-line version of the applicable document identifying specific proposed modifications to the model agreement language, as well as a detailed explanation and supporting rationale for each modification. General comments without proposed alternate language, drafting notes without explanation or alternate language, footnotes such as "parties to discuss," or a reservation of rights to make additional modifications to the model agreements at a later time are unacceptable, will be considered unresponsive, and will result in a lower score. See also Section 3.8. The Company and Independent Observer will evaluate the impact that the proposed modifications will have on the overall risk assessment associated with the evaluation of each Proposal.

11. **Guaranteed Commercial Operations Date** – Proposers that are able to design for and commit to an earlier GCOD will be given more favorable scoring. Proposers will be held to the GCOD identified in their Proposal. The GCOD will be a Guaranteed Milestone and will be inserted without amendment into the RDG PPA, as applicable.
12. **Cultural Resource Impacts** – At a minimum, Proposers should provide a plan to select and engage with a consultant to assess if there are any historical and/or cultural resources at the Site and how any potential historical or cultural resource issues that arise during the term will be addressed. Proposals will also be evaluated on the extent to which their cultural impact assessment plan has been developed and preference will be given to Proposals that are further along in the assessment process, including but not limited to whether a mitigation/action plan has been provided that addresses any identified cultural resource issues, or a date for when such a plan will be available has been identified, or any portions of such plan have been completed.

4.5 Selection of the Final Award Group

At the conclusion of both the price and non-price analysis, a total score will be calculated for each Eligible Proposal using the 51% price-related criteria/ 49% non-price-related criteria weighting outlined above. The price and non-price analysis, and the summation of both price and non-price scores described above, will result in a ranking of Proposals.

Based on the results of this Evaluation and review with the Independent Observer, the Company will select a Proposal to the Final Award Group from which to begin contract negotiations. All Proposers will be notified at this stage of the evaluation process whether their Proposal is included in the Final Award Group.

Selection to the Final Award Group and/or entering into contract negotiations does not guarantee execution of a PPA.

Further, if at any time during the evaluation process it is discovered that a Proposer's Proposal contains incorrect or misrepresented information that have a material effect on any of the evaluation processes, including selection of the Final Award Group, the Company reserves the right, at any time prior to submission of the PPA application with the PUC, in consultation with the Independent Observer, to disqualify the Proposer from the RFP. If discovery of the incorrect or misrepresented information is made after the Company has filed its PUC application for approval of the PPA with the Proposer, the Company will disclose the incorrect or misrepresented information to the PUC for evaluation and decision as to whether such Proposer should be disqualified and the Company's application dismissed.

Following any removal of a Proposal from the Final Award Group, either by disqualification noted immediately above, or via any other removal or withdrawal of a Proposal, including failure to reach agreement on the PPA, the Company, taking into consideration the timing of such removal and the current status of the Company's needs

under the RFP, in consultation with and concurrence from the Independent Observer, will determine if another Proposal should be added to the Final Award Group.

Chapter 5: Post Evaluation Process

5.1 Interconnection Requirements Study Process

A complete package of Project Interconnection Data Request worksheets and project single line diagram(s) shall be submitted with each Proposal. The models for equipment and controls, list(s) to clearly identify the components and respective files (for inverters and power plant controller), three line diagram which shows the Point of Interconnection, potential transformer (PT) and current transformer (CT) ratios, and details of the generating facility configuration, including relays, meters, and test switches, and complete documentation with instructions, shall be submitted within 30 after selection of the Final Award Group. See Section 2.11.1 of Appendix B. PSSE Generic models, PSSE User models, and ASPEN models shall be configured to represent all of the functional equipment with settings in place to comply with the Company's PPA performance requirements. These must be checked for functionality by the Proposer or its vendors and consultants prior to submission to the Company. Similar and fully accurate PSCAD models shall be submitted in a condition that complies with the PSCAD modeling guidelines provided by the Company. PSSE generic models shall be provided promptly after the PSSE user models have been approved by the Company.

After proposals and models are submitted, the Company will inspect the data packages for general completeness. For any incomplete submissions, a list of missing or non-functional items will be provided. Proposers will be given 15 Days to resolve data and modeling deficiencies. The Company, in consultation with the Independent Observer, may remove Proposals from being selected to the Final Award Group or may terminate PPA negotiations or executed PPAs, if their submission requirements are deemed incomplete for the lack of requested models. Proposals that are complete will be considered for further evaluation. A formal, technical model checkout will be deferred until a later date when IRS Agreements and deposits are in place, so that the expert subject matter work can be provided by the Company's IRS consultant(s).

Upon notification of selection to the Final Award Group, the Company will provide a draft IRS Agreement for the selected project, with a statement of required deposit for individual and prorated work as part of an IRS Scope for a System Impact Study that will involve (a) technical model checkout for the project and (b) any considerations that are specific to the particular project and location. Interconnection cost and schedule, including cost of any required system upgrades, will be determined in a subsequent Facility Study.

The technical model checkouts will be conducted first. Upon identification of any functional problems or deficiencies, corrective action shall be taken immediately and on an interactive basis so that the problems or deficiencies can be resolved within 15 Days, including re-submission of data and updated models, or the Project shall be deemed withdrawn. At the discretion of the Company and provided that there is a demonstration

of good faith action to minimize delay that would affect the schedule for IRS analyses, a second round of model checkout and problem solving may proceed. Thereafter any notice that a Project is deemed withdrawn for lack of completeness shall be final. Subject to consultation with the Independent Observer, failure to provide all requested material within the time(s) specified, or changes to the data provided after the due date(s), shall result in elimination from the Final Award Group.

Proposers shall be responsible for the cost of the IRS, under separate agreements for the System Impact Study and the Facility Study. The overall IRS will provide information including, but not limited to, an estimated cost and schedule for the required Interconnection Facilities for a particular Project and any required mitigation measures. Proposers will be responsible for the actual final costs of all Seller-Owned Interconnection Facilities and Company-Owned Interconnection Facilities. Upon reviewing the results of the IRS, Proposers will have the opportunity to declare the PPA null and void in the event that the estimated interconnection costs and schedule for the Project are higher than what was estimated in the Project Proposal. See Section 12.4 of the RDG PPA.

5.2 Contract Negotiation Process

Within five (5) business Days of being notified by the Company of its intent to enter into contract negotiations, the Proposer selected to the Final Award Group will be required to indicate, in writing to the Company's primary contact for this RFP, whether it intends to proceed with its Proposal. The awarded Proposer will be required to keep its Proposal valid through the award period. Contract negotiations will take place in parallel with the IRS process. The Company intends to execute and file the PPA with the PUC for approval and later amend the PPA to include the results of the IRS.

5.3 Final Award Group Commitments

5.3.1 Community Outreach and Engagement / Cultural Resource Impacts

The public meeting and comment solicitation process described in this Section and Section 29.21 of the PPA (Community Outreach Plan) do not represent the only community outreach and engagement activities that can or should be performed by a Proposer.

The Company will publicly announce the Final Award Group no more than 5 business days after the notification is given to Proposers who are selected to the Final Award Group. Selected Proposers shall not disclose their selection to the public before the Company publicly announces the Final Award Group selection.

On the next business day after the Company notifies a Proposer they were selected, each Proposer shall provide the Company with links to their Project website, which the Company will post on the Company's website. Each Proposer will launch a Project website that will go-live on the day the Company publicly announces the Final Award Group selection. Information on what should be included on the Project website is identified in Appendix B.

Within five (5) business days of notification of selection to the Final Award Group, Proposers must have provided the Company with an updated comprehensive Community Outreach Plan to work with and inform neighboring communities and stakeholders and to provide them timely information during all phases of the Project. The Community Outreach Plan shall include but not be limited to the following information: Project description, Project stakeholders, community concerns and Proposer's efforts to address such concerns, Project benefits, government approvals, Project schedule, and a comprehensive communications plan. The Proposer's Community Outreach Plan shall be a public document available to the public on the Proposer's website and upon request. As an option, Proposers may provide their updated Community Outreach Plan and website information to the Company for review and feedback. If provided at least 30 days prior to the dates required, the Company will endeavor to review such information and provide feedback on the information before it is made available to the public. Details on the Community Outreach Plan can be found in Appendix B, Attachments 4 and 5.

Prior to the execution date of the PPA, Proposers shall also host a public meeting in the community where the proposed Project is to be located for community and neighborhood groups in and around the vicinity of the Project Site that provided the neighboring community, stakeholders and the general public with: (i) a reasonable opportunity to learn about the proposed Project; (ii) an opportunity to engage in a dialogue about concerns, mitigation measures, and potential community benefits of the proposed Project; and (iii) information concerning the process and/or intent for the public's input and engagement, including advising attendees that they will have thirty (30) calendar days from the date of said public meeting to submit written comments to Company and/or Proposer for inclusion in the Company's submission to the PUC of its application for a satisfactory PUC Approval Order. The Proposer shall collect all public comments, and then provide the Company copies of all comments received in their original, unedited form, along with copies of all comments with personal information redacted and ready for filing. If a PPA is executed by the Proposer and the Company, the Company may submit any and all public comments (presented in its original, unedited form) as part of its PUC application for this Project. Proposers shall notify the public at least three weeks in advance of the meeting. The Company shall be informed of the meeting. The Company has provided Proposers with detailed instructions regarding the community meeting requirement after the selection of the Final Award Group (Attachment 4 to Appendix B). (For example, notice will be published in county or regional newspapers/media, as well as media with statewide distribution. The Proposer will be directed to notify certain individuals and organizations. The Proposer will be provided templates to use for the public meeting notices, agenda, and presentation.) Proposers must also comply with any other requirement set forth in the PPA relating to Community Outreach.

Following the submission of the PUC application for the Project, and prior to the date when the Parties' statements of position are to be filed in the docketed PUC proceeding for the Project, the Proposer shall provide another opportunity for the public to comment on the proposed Project. The Proposer's statement of position filed in the docket associated with the Project will contain an attachment including those comments.

The Proposer shall be responsible for community outreach and engagement for the Project, and that the public meeting and comment solicitation process described in this section do not represent the only community outreach and engagement activities that can or should be performed.

Within 5 Days of the start of PPA negotiations, the Proposer shall contract with a consultant to begin a cultural impact assessment for the Project. The consultant shall identify (1) valued cultural, historical, or natural resources in the area in question, including the extent to which traditional and customary native Hawaiian rights are exercised in the area; (2) the extent to which those resources – including traditional and customary native Hawaiian rights – will be affected or impaired by the proposed action; and (3) the feasible action, if any, to be taken to reasonably protect native Hawaiian rights if they are found to exist.

5.3.2 Ocular Impact Study

Due to the proximity to the Lāna‘i Airport, the Proposer shall complete an ocular impact study for review by the State of Hawai‘i Department of Transportation and any other federal or state agency that may request such study. When designing the facility, the developer should take care to develop panel placement and select materials that will not result in glint and glare issues for air traffic at the Lāna‘i Airport.

5.4 Greenhouse Gas Emissions Analysis

The Proposer whose Proposal is selected for the Final Award Group shall cooperate with and promptly provide to the Company and/or Company’s consultant(s) upon request, all information necessary, in the Company’s sole and exclusive discretion, for such consultant to prepare a greenhouse gas (“GHG”) emissions analysis and report in support of a PUC application for approval of the PPA for the project (the “GHG Review”). Proposers shall be responsible for the full cost of the GHG Review associated with their project under a Greenhouse Gas Analysis Letter Agreement between the Proposer and the Company. The GHG Review is anticipated to address whether the GHG emissions that would result from approval of the PPA and subsequent to addition of the Project to the Company’s system are greater than the GHG emissions that would result from the operations of the Company’s System without the addition of the Project, whether the cost for renewable, dispatchable generation, and/or energy storage services as applicable under the PPA is reasonable in light of the potential for GHG emissions, and whether the terms of the PPA are prudent and in the public interest in light of its potential hidden and long-term consequences.

5.5 PUC Approval of PPA

Any signed PPA resulting from this RFP is subject to PUC approval as described in the RDG PPA, including Article 12 and Section 29.20 thereof.

5.6 Facility In-Service

In order to facilitate the timely commissioning of the project selected through this RFP, the Company requires the following be included with the 60% design drawings: relay settings and protection coordination study, including fuse selection and ac/dc schematic trip scheme.

For the Company to test the Facility, coordination between the Company and Project is required. Drawings must be approved by the Company prior to testing. The entire Facility must be ready for testing to commence. Piecemeal testing will not be allowed. Communication infrastructure and equipment must be tested by the Proposer and ready for operation prior to Company testing.

If approved drawings are not available, or if the Facility is otherwise not test ready as scheduled, the Project will be moved to the end of the Company's testing queue. If tests are not completed within the allotted scheduled testing time, the Project will be moved to the end of the Company's testing queue. The Proposer will be allowed to cure if successful testing is completed within the allotted scheduled time. No adjustments will be made to PPA milestones if tests are not completed within the original allotted time. Liquidated damages for missed milestones will be assessed pursuant to the PPA.

DRAFT

REQUEST FOR PROPOSALS

FOR

VARIABLE RENEWABLE DISPATCHABLE GENERATION

PAIRED WITH ENERGY STORAGE

AND

COMMUNITY-BASED RENEWABLE ENERGY

ISLAND OF LĀNA‘I

SEPTEMBER 8, 2020

Docket No. 2015-0389

Appendix A – Definitions

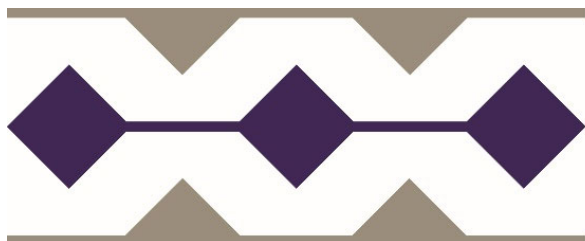

**Maui
Electric**

“Affiliate” means any person or entity that possesses an “affiliated interest” in a utility as defined by section 269-19.5, Hawaii Revised Statutes (“HRS”), including a utility’s parent holding company but excluding a utility’s subsidiary or parent which is also a regulated utility.

“Allowed Capacity” has the meaning set forth in the RDG PPA.

“Code of Conduct” means the code of conduct approved by the PUC in Docket No. 03-0372 (Decision and Order No. 23614, August 28, 2007) with respect to a Self-Build Option. An updated code of conduct was submitted to the PUC in Docket No. 2015-0389 on July 9, 2020.

“Code of Conduct Procedures Manual” or “Procedures Manual” means the manual approved by the PUC, which was put in place to address and to safeguard against preferential treatment or preferential access to information in a Hawaiian Electric, Maui Electric, or Hawaii Electric Light RFP process. The Procedures Manual is attached as Appendix C to this RFP.

“Commercial Operations” has the meaning set forth in the RDG PPA.

“Community Outreach Plan” is a community outreach and communication plan described in Section 4.3 and 4.4.2 of this RFP.

“Company” means Maui Electric Company, Ltd., a Hawai‘i corporation.

“Company-Owned Interconnection Facilities” has the meaning set forth in the RDG PPA.

“Competitive Bidding Framework” or “Framework” means the Framework for Competitive Bidding contained in Decision and Order No. 23121 issued by the Public Utilities Commission on December 8, 2006, and any subsequent orders providing for modifications from those set forth in Order No. 23121 issued December 8, 2006.

“Consumer Advocate” means the Division of Consumer Advocacy of the Department of Commerce and Consumer Affairs of the State of Hawai‘i.

“Day” means a calendar day, unless the term “business day” is used, which means calendar day excluding weekends and federal and State of Hawai‘i holidays.

“Development Period Security” has the meaning set forth in Section 14.2 of the RDG PPA.

“Dispatchable” means the ability to turn on or turn off a generating resource at the request of the utility’s system operators, or the ability to increase or decrease the output of a generating resource from moment to moment in response to signals from a utility’s Automatic Generation Control System, Energy Management System or similar control system, or at the request of the utility’s system operators.

“Electronic Procurement Platform” means the third-party web-based sourcing platform that will be used for the intake of Proposals and associated electronic information, storage and handling of Proposer information, and communication.

“Eligibility Requirements” has the meaning set forth in Section 4.2 of this RFP.

“Eligible Proposals” means Proposals that meet both the Eligibility and Threshold Requirements.

“Energy Contract Manager” is the primary Company contact for this RFP.

“Evaluation Team” means agents of the Company who evaluate Proposals.

“Facility” has the meaning set forth in the RDG PPA.

“Facility Study” means a study to develop the interconnection facilities cost and schedule estimate including the cost associated with the design and construction of the Company-owned interconnection facilities.

“Final Award Group” means the Proposer selected by the Company which the Company will begin contract negotiations with, based on the results of the Company’s evaluation.

“Greenhouse Gas” or “GHG” are gases that contribute to the greenhouse gas effect and trap heat in the atmosphere.

“Guaranteed Commercial Operations Date” or “GCOD” means the date on which a Facility first achieves Commercial Operations.

“Hawaiian Electric” means Hawaiian Electric Company, Inc., a Hawai‘i corporation.

“Hawaiian Electric Companies” or “Companies” means Hawaiian Electric Company, Inc. and its subsidiaries, Hawaii Electric Light Company, Inc. and Maui Electric Company, Limited.

“HRS” means the Hawai‘i Revised Statutes as of the date of this Request for Proposals.

“Imputed Debt” means adjustments to the debt amounts reported on financial statements prepared under generally accepted accounting principles (“GAAP”). Certain obligations do not meet the GAAP criteria of “debt” but have debt-like characteristics; therefore, credit rating agencies “impute debt and interest” in evaluating the financial ratios of a company.

“Independent Observer” has the meaning set forth in Section 1.4 of this RFP.

“Independent Power Producer” or “IPP” means an entity that owns or operates an electricity generating facility that is not included in the Company’s rate base.

“Interconnection Facilities” means the equipment and devices required to permit a Facility to operate in parallel with, and deliver electric energy to, the Company System (in accordance with applicable provisions of the Commission’s General Order No. 7, Company tariffs, operational practices, interconnection requirements studies, and planning criteria), such as, but not limited to, transmission and distribution lines, transformers, switches, and circuit breakers. Interconnection Facilities includes Company-Owned Interconnection Facilities and Seller-Owned Interconnection Facilities.

“Interconnection Requirements Study” or “IRS” means a study, performed in accordance with the terms of the IRS Letter Agreement, to assess, among other things, (1) the system requirements and equipment requirements to interconnect the Facility with the Company

System, (2) the Performance Standards of the Facility, and (3) an estimate of interconnection costs and project schedule for interconnection of the Facility.

“kV” means kilovolt.

“Levelized Benefit” or “LB” means a calculation (\$/MWh) used for comparison of Proposals based on information provided in the Proposal submission in this RFP.

“Low- and Moderate-Income Customer” or “LMI Customer” is as defined in Tariff Rule No. 29 in Appendix J.

“Lump Sum Payment” has the meaning set forth in the RDG PPA. It may also be referred to as a monthly Lump Sum Payment to reflect the portion of the payment made each month.

“Maui Electric” means Maui Electric Company, Ltd., a Hawai‘i corporation.

“Maui Electric System” or “System” means the electric system owned and operated by Maui Electric on the island of Lāna‘i (including any non-utility owned facilities) consisting of power plants, transmission and distribution lines, and related equipment for the production and delivery of electric power to the public.

“Mediation” means the confidential mediation conducted in Honolulu, Hawai‘i, pursuant to and in accordance with the Mediation Rules, Procedures, and Protocols of Dispute Prevention Resolution, Inc. (or its successor) or, in its absence, the American Arbitration Association then in effect.

“MW” means megawatt.

“MWh” means megawatt hour.

“NDA” means the Mutual Confidentiality and Non-Disclosure Agreement attached to this RFP as Appendix E.

“NEP” means Net Energy Potential.

“Non-Price Evaluation Team” means Employees and consultants of the Company who evaluate the Proposal non-price related criteria as set forth in Section 4.4 of this RFP. Non-Price Evaluation Team members will not include any Shared Resources and will be solely made up of Company RFP Team Members.

“O&M” means operation and maintenance.

“Operating Period Security” has the meaning set forth in Section 14.4 of the RDG PPA.

“Performance Standards” means the various performance standards for the operation of the Facility to the Company as set forth in Section 2.10 of Appendix B, as such standards may be revised from time to time pursuant to Article 23 of the RDG PPA, and as described in Chapter 2 of this RFP.

“Point of Interconnection” has the meaning set forth in the RDG PPA.

“Power Purchase Agreement” or “PPA” means an agreement between an electric utility company and the developer of a renewable energy generation facility to sell the power generated by the facility to the electric utility company.

“Price Evaluation Team” means Employees and consultants of the Company who evaluate the Proposal price related criteria as set forth in Section 4.4 of this RFP. Price Evaluation Team members will not include any Shared Resources and will be solely made up of Company RFP Team Members.

“Project” means a Facility proposed to Maui Electric by a Proposer pursuant to this RFP.

“Proposal” means a proposal submitted to Maui Electric by a Proposer pursuant to this RFP.

“Proposal Due Date” means the date stated in RFP Schedule - Row 6 for the Self-Build Proposal and Row 7 for the IPP and Affiliate Proposal of this RFP.

“Proposal Fee” means the non-refundable fee for each proposal submitted as set forth in Section 1.8 of this RFP.

“Proposer” means a person or entity that submits a Proposal to Maui Electric pursuant to this RFP.

“Proposer’s Response Package” means the form in which the Proposal should be submitted, which is attached as Appendix B to this RFP.

“PUC” means the State of Hawai‘i Public Utilities Commission.

“RDG PPA” means the Model PV + BESS Renewable Dispatchable Generation Power Purchase Agreement attached as Appendix L to this RFP.

“Renewable Portfolio Standards” or “RPS” means the Hawai‘i law that mandates that the Company and its subsidiaries generate or purchase certain amounts of their net electricity sales over time from qualified renewable resources. The RPS requirements in Hawai‘i are currently codified in HRS §§ 269-91 through 269-95.

“Request for Proposals” or “RFP” means a request for Proposals issued pursuant to a competitive bidding process authorized, reviewed, and approved by the PUC.

“RFP Schedule” means the schedule set forth in Table 1, Section 3.1 of this RFP.

“Self-Build Option” or “SBO” means a Proposal submitted by the Company that is responsive to the resource need identified in the RFP, as required by Section VI of the Framework.

“Self-Build Team” means agents of the Company who develop Self-Build Option proposals.

“Seller” means the entity that the Company is contracting with, as set forth in the RDG PPA.

“Seller-Owned Interconnection Facilities” has the meaning set forth in the RDG PPA.

“Site” means the parcel of real property on which the Facility, or any portion thereof, will be constructed and located, together with any Land Rights reasonably necessary for the construction, ownership, operation, and maintenance of the Facility.

“System Impact Study” means a study analyzing the steady-state and dynamic impacts on system power flow, voltage, frequency and transient stability. The analyses includes compatibility of design, construction and operation of the Project with Company engineering standards and operating practices.

“Threshold Requirements” has the meaning set forth in Section 4.3 of this RFP.

Any capitalized term not defined in this RFP has the meaning set forth in the RDG PPA.

DRAFT

REQUEST FOR PROPOSALS

FOR

VARIABLE RENEWABLE DISPATCHABLE GENERATION

PAIRED WITH ENERGY STORAGE

AND

COMMUNITY-BASED RENEWABLE ENERGY

ISLAND OF LĀNA‘I

SEPTEMBER 8, 2020

Docket No. 2015-0389

*Appendix B – Proposer’s Response Package /
Project Interconnection Data Request*

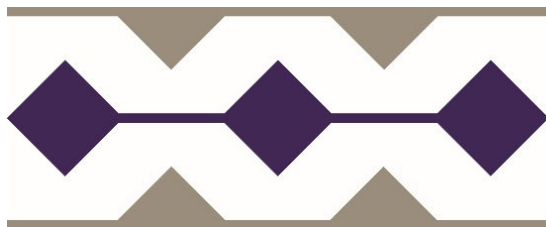

**Maui
Electric**

1.0 GENERAL INSTRUCTIONS TO PROPOSERS

The Company has elected to use the services of PowerAdvocate®, a third-party electronic platform provider. Sourcing Intelligence®, developed by PowerAdvocate®, is the Electronic Procurement Platform that the Company has licensed and will utilize for the RFP process. All Proposals and all relevant information must be submitted via the Electronic Procurement Platform, in the manner described in this RFP.

Proposers must adhere to the response structure and file naming conventions identified in this Appendix for the Proposer's response package. Information submitted in the wrong location/section or submitted through communication means not specifically identified by the Company will not be considered by the Company.

Proposers must provide a response for every item. If input/submission items in the RFP are not applicable to a specific Proposer or Proposal, Proposers must clearly mark such items as "N/A" (Not Applicable) and provide a brief explanation.

Proposers must clearly identify all confidential information in their Proposals, as described in more detail in Section 3.12 of the RFP.

All information (including attachments) must be provided in English. All financial information must be provided in U.S. Dollars and using U.S. credit ratings.

It is the Proposer's sole responsibility to notify the Company of any conflicting requirements, ambiguities, omission of information, or the need for clarification prior to submitting a Proposal.

The RFP will be conducted as a "Sealed Bid" event within Sourcing Intelligence, meaning the Company will not be able to see or access any of the Proposer's submitted information until after the event closes.

1.1 ELECTRONIC PROCUREMENT PLATFORM

To access the RFP event, the Proposer must register as a "Supplier"¹ on Sourcing Intelligence (Electronic Procurement Platform). One Proposal may be submitted with each Supplier registration.

If a Proposer is already registered on Sourcing Intelligence, the Proposer may use their current login information to submit their Proposal. Proposers are asked to refer to their chosen unique company name throughout when referring to it in text responses.

Proposers can register for an account on Sourcing Intelligence by clicking on the "Registration" button (located in the top right corner of the webpage) on the PowerAdvocate website at the following address:

www.poweradvocate.com

The Proposer's use of the Electronic Procurement Platform is governed by PowerAdvocate's Terms of Use. By registering as a "Supplier" on the Electronic Procurement Platform, the Proposer acknowledges that the Proposer has read these Terms of Use and accepts and agrees that, each time the Proposer uses the Electronic Procurement

¹ The language in Appendix B sometimes refers to "Energy Contract Managers" as "Bid Event Coordinator" and to "Proposers" as "Suppliers" (Bid Event Coordinator and Supplier are terms used by PowerAdvocate).

Platform, the Proposer will be bound by the Terms of Use then accessible through the link(s) on the PowerAdvocate login page.

Once a Proposer has successfully registered as a “Supplier” with PowerAdvocate, the Proposer shall request access to the subject RFP event from the Company Contact via Email through the RFP Email address set forth in Section 1.6 of the RFP. The Email request must list the Company Name field and username under which the Proposer has registered with PowerAdvocate. After being added to the event, the Proposer will see the bid event on their dashboard upon logging into Sourcing Intelligence. Once the RFP event opens, the Proposer may begin submitting their Proposal.

After registering and prior to the opening of the RFP, Proposers are encouraged to familiarize themselves with the Electronic Procurement Platform, including tabs, the dashboard, PowerAdvocate Users Guide (RFP Appendix D), etc. Proposers should note that they will not be able to access any bid documents until the event officially opens.

Proposers may contact PowerAdvocate Support for help with registration or modification of registration if desired. Support is available from 8 AM to 8 PM Eastern Time (2 AM to 2 PM Hawai‘i Standard Time when daylight savings is in effect) Monday to Friday, except for Holidays posted on the PowerAdvocate website, both by phone (857-453-5800) and by Email (support@poweradvocate.com).

Contact information for PowerAdvocate Support can also be found on the bottom border of the PowerAdvocate website: www.poweradvocate.com

Once the RFP event is opened, registered Proposers will have online access to general notices and RFP-related documents via the Electronic Procurement Platform. Proposers should also monitor the RFP Website throughout the RFP event.

1.2 PROPOSAL SUBMISSION PROCEDURES

An Email notification will be sent to all registered Proposers when the event has been opened to receive Proposals.

After logging onto the Electronic Procurement Platform, the RFP will be visible on the Proposer’s dashboard with several tabs, including the following:

- **“1. Download Documents:”** Documents stored under this tab are provided for the Proposer’s use and information. All documents can be downloaded and/or printed, as required.
- **“2. Upload Documents:”** Proposal submission documents requested in Appendix B must be uploaded using this tab.
- Note that “3. Commercial Data:”, “4. Technical Data:”, and “5. Pricing Data:” tabs are NOT USED for this event.

Step-by-step instructions for submitting a complete Proposal are provided below:

1. Proposers must upload their Proposal files, including all required forms and files, to submit a complete Proposal. Self-Build, IPP and Affiliates must upload all files before their respective Proposal Due Date (RFP Section 3.1 Items 6 for Self-Build and Item 7 for IPP and Affiliates).

2. Submit (upload) one consolidated PDF representing your Proposal via the “2. Upload Documents” tab. That Proposal PDF must abide by the format specified in this Appendix B. A MSWord.docx template that outlines the format of this document is available under the “1. Download Documents” tab for the Proposer’s use. **Response information must be provided in the order, format, and manner specified in this Appendix B and must clearly identify and reference the Appendix B section number that the information relates to.**
 - a. Proposers shall use a filename denoting: CompanyName.pdf.
(example: AceEnergy.pdf)
3. Proposal information that cannot be easily consolidated into the PDF file described in Step 2 (such as large-scale drawing files) or files that must remain in native file format (such as computer models and spreadsheets) shall be **uploaded separately but must be referenced from within the main Proposal PDF file** (e.g., “See AceEnergy_2.5_SiteMap.kmz”). Such additional files must follow the naming convention below:
 - a. File names must include, in order, Company Name, Appendix B section number, and a file descriptor, as shown in the example file name below:
AceEnergy_2.5_SiteMap.kmz
Proposers may use abbreviations if they are clear and easy to follow.
4. Upload files using the **"2. Upload Documents"** tab on the Electronic Procurement Platform.
 - a. For all documents identify the "Document Type" as “Technical Information.” (Do not identify any documents as “Commercial and Administrative” or “Pricing.”)
 - b. "Reference ID" may be left blank.
 - c. Select "Choose File..." Navigate to and choose the corresponding file from your computer. Select "Open" and then "Submit Document."

There is no limit to the number or size of files that can be uploaded. Multiple files may be grouped into a .zip archive for upload. (Any zipped files must still adhere to the naming directions in #3 above.) When successfully uploaded, documents will appear under the "Bid Submissions" section on the bottom of the tab's page, organized within the “Technical Information” Document Type. Repeat steps a, b, and c, as required for each file upload.

If a file with the same name is uploaded twice, the Platform will automatically append a unique numerical extension to the Document Name. To delete a file that has been previously uploaded, click on the “X” button in the “Actions” column for the file to be deleted. Do not upload any files prior to the issuance of the Final RFP.

5. The Company will not be responsible for technical problems that interfere with the upload or download of Proposal information. Support is available to answer technical questions about PowerAdvocate’s Sourcing Intelligence from 8 AM to 8 PM Eastern Time (2 AM to 2 PM Hawai‘i Standard Time when daylight savings is in effect) Monday to Friday, except for Holidays posted on the PowerAdvocate website, both by phone (857-453-5800) and by Email (support@poweradvocate.com).

6. Proposers are strongly encouraged to start early and avoid waiting until the last minute to submit the required information. Proposers are allowed to add, modify, and/or delete documents that have been previously submitted any time prior to the event close deadline. Repeating, it is the Proposer’s responsibility to ensure a complete Proposal is uploaded into PowerAdvocate before the Proposal Due Date.
7. Any questions or concerns regarding the RFP may be submitted to the Company Contact via the RFP Email address provided in Section 1.6 of the RFP. Per RFP Section 1.4.2, the Independent Observer will monitor messages within the bid event. Proposers are responsible for following instructions and uploading documents in their appropriate locations. Documents uploaded in the wrong tab will not be considered by the Company.

1.3 PROPOSAL COMPLETION AND CONFIRMATION PROCEDURES

To confirm the submission of all proposal files, in the “Status” tab on the Electronic Procurement Platform, confirm that the “Total Uploaded Files” is the number of expected files to be included in the submission by checking it against your list of submitted files.

Example “Status” tab view:

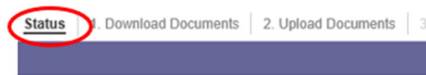

Your Bid Intention: Bidding	
Total Uploaded Files:	0
Saved Commercial Datasheets:	0 of 0
Saved Technical Datasheets:	0 of 0
Saved Pricing Datasheets:	0 of 0

Your Bid Intention: Bidding		
Total Uploaded Files:	18	Last Upload: 02/08/18
Saved Commercial Datasheets:	1 of 1	Last Saved: 02/08/18
Saved Technical Datasheets:	0 of 0	
Saved Pricing Datasheets:	1 of 1	Last Saved: 02/08/18

No documents should be uploaded to the Commercial, Technical, or Pricing Datasheet tabs. Documents uploaded there will not be included in your Proposal submission.

2.0 PROPOSAL SUMMARY TABLE

To be filled out completely by IPP or Affiliate Proposers:

1	Proposer Name (Company Name)	
2	Parent Company/Owner/Sponsor/Business Affiliation/etc.	
3	Project Name	
4	Net AC Capacity of the Facility (MW)	
5	Net Energy Potential (NEP) Projection for the Facility (MWh)	
6	Lump Sum Payment (\$/Year)	
7	Project Energy Storage Technology	
8	Energy Storage Capability for the Facility (MW and MWh)	
9	Is the Project capable of being 100% charged from the grid after the 5 year ITC recapture period? (Yes/No)	
10	The Proposer hereby certifies that no single point of failure from the Facility shall result in a decrease in net electrical output greater than 2.5 MW. (Yes/No)	
11	Is the Project grid-forming and black start capable? (Yes/No)	
12	Proposal Guaranteed Commercial Operations Date (MM/DD/YYYY)	
13	The Proposer hereby certifies that the Project meets all performance attributes identified in this Section 2.1 of the RFP? (Yes/No)	
14	The Proposer hereby certifies that the Proposal (including its pricing elements) is not contingent upon changes to existing County, State, or Federal laws or regulations. (Yes/No)	
15	The Proposer hereby agrees to provide Development Period Security and Operating Period Security as set forth in the applicable RDG PPA. (Yes/No)	
16	The Proposer hereby certifies under penalties of perjury that this Proposal has been made in good faith and without collusion or fraud with any other person. As used in this certification, the word "person" shall mean any natural person, business partnership, corporation, union, committee, club, or organization, entity, or group of individuals. (Yes/No)	
17	The Proposer hereby certifies that the Proposer, its parent company, or any affiliate of the Proposer has not either defaulted on a current contract with the Company, had a contract terminated by the Company, or has any pending litigation with the Company (Yes/No)	

To be filled out completely by Self-Build Proposers:

1	Proposer Name (Company Name)		
2	Parent Company/Owner/Sponsor/Business Affiliation/etc.		
3	Project Name		
4	Net AC Capacity of the Facility (MW)		
5	Net Energy Potential (NEP) Projection for the Facility (MWh)		
6	Project Energy Storage Technology		
7	Energy Storage Capability for the Facility (MW and MWh)		
8	Is the Project capable of being 100% charged from the grid after the 5 year ITC recapture period? (Yes/No)		
9	The Proposer hereby certifies that no single point of failure from the Facility shall result in a decrease in net electrical output greater than 2.5 MW. (Yes/No)		
10	Is the Project grid-forming and black start capable? (Yes/No)		
11	Proposal Guaranteed Commercial Operations Date (MM/DD/YYYY)		
12	The Proposer hereby certifies that the Project meets all performance attributes identified in Section 2.1 of the RFP? (Yes/No)		
13	The Proposer hereby certifies that the Proposal (including its pricing elements) is not contingent upon changes to existing County, State or Federal laws or regulations. (Yes/No)		
14	The Proposer hereby agrees to provide Development Period Security and Operating Period Security as set forth in the applicable Model RDG PPA or Model Mid-Tier SFC. (Yes/No)		
15	The Proposer hereby certifies under penalties of perjury that this Proposal has been made in good faith and without collusion or fraud with any other person. As used in this certification, the word "person" shall mean any natural person, business partnership, corporation, union, committee, club, or organization, entity, or group of individuals. (Yes/No)		
16	Year (YYYY)	Project Capital Cost (\$)	Extend the table for questions 16, 17, and 18 for as many years as needed up to the 20-year PPA term.
17	Year (YYYY)	O&M Cost (\$)	
18	Year (YYYY)	Annual Revenue Requirement (\$)	

2.1 REQUIRED FORMS ACCOMPANYING PROPOSAL PDF

The following forms must accompany each proposal, must be attached to the Proposal PDF, and uploaded via the “2. Upload Documents” tab:

- Document signed by a representative for the Proposer **authorizing the submission** of the Proposal
- Fully executed **Mutual Confidentiality and Non-Disclosure Agreement (“NDA”)** (Appendix E to the RFP, may be downloaded from the “1. Download Documents” tab in the Electronic Procurement Platform) or fully executed **NDA** for the Request for Proposal for Variable Renewable Dispatchable Generation Paired with Energy Storage, Island of Lāna‘i, dated November 29, 2019.
- **Certificate of Vendor Compliance** for the Proposer
 - **Certificate of Good Standing** for the Proposer and **Federal and State tax clearance certificates** for the Proposer may be provided in lieu of the Certificate of Vendor Compliance
- **Certification of Counsel for Proposer**, if applicable. (See Appendix B Attachment 1.)
- Completed applicable **Interconnection Requirement Study Data Request form** for the proposed technology and **project single line diagram(s). Models for equipment and controls, list(s)** identifying components and respective files (for inverters and power plant controller), and **complete documentation with instructions** as specified in the Data Request form shall be submitted within the respective timeframes specified in Section 5.1 of the RFP.² (See Section 2.11.1 below)
- [For Self-Build Only] **Self-Build Option Team Certification Form**. See Appendix G Attachment 1.
- [For Self-Build Only] **Revenue Requirements Worksheets** that support the annual revenue requirements estimates shall be submitted. A starter revenue requirements template file can be requested by the Self-Build Team via email to the RFP Email Address or through the PowerAdvocate Messaging function once the RFP event opens. The revenue requirements worksheets submitted will be modified to reflect the details of the Project’s Proposal. All assumptions used will be reflected in an assumptions input tab.

2.2 PROPOSAL SUMMARY/CONTACT INFORMATION

2.2.1 Provide a **primary point of contact** for the Proposal being submitted:

- Name
- Title
- Mailing Address
- Phone Number
- Email Address - this will be the official communication address used during the RFP process

2.2.2 **Executive Summary of Proposal.** The executive summary must include an approach and description of the important elements of the Proposal.

² If the Models, lists, respective files and complete documentation are not submitted with the Proposal upload, they shall be submitted via PowerAdvocate’s Messaging as attachments within the respective timeframes specified in Section 5.1 of the RFP.

2.2.3 **Pricing information.** Pricing information must be filled out in the Section 2.0 Proposal Summary Table above. Provide any pricing information only in those table sections – do not embed pricing information in any other portion of the Proposal PDF.

2.2.4 Provide a **high-level overview of the proposed Facility**, including at a minimum the following information:

- Facility Generation Size (MW_{AC} and MW_{DC})
- Net Maximum Output Capacity of the Facility at the Point of Interconnection (MW_{AC})
- Identified Available Hosting Capacity of the Distribution-level Circuit Facility Interconnecting to (MW_{AC})
- Technology Type
- Number of Generators
- Rated Output of each Generator
- Generator Facility Design Characteristics

For Storage Component:

- Technology Type (i.e. lithium ion battery)
- Discharge Duration (hours)
- Storage Capacity (i.e. amount of energy released to fully discharge and amount of energy required to fully charge, in MW and MWh)
- Operational Limitations, such as, but not limited to: number of charge/discharge cycles per day-month-year (see the energy discharge requirement in Section 1.2.9 of the RFP; however, operational limitations may not restrict the requirements set forth in these sections).
- Minimum and Maximum Operational Ranges, such as minimum and maximum required state of charge
- Round Trip Efficiency at rated power measured at the Point of Interconnection (i.e., discharge energy divided by charge energy, expressed as a percentage). Specify only a single value that the Facility will maintain throughout the term of the PPA. (See RFP Section 3.10.2).
- Round Trip Efficiency using full duty cycle for a fixed duration measured at the Point of Interconnection (%)
- Estimated useful life of the storage component.

2.3 FINANCIAL

Provide the following financial information identified below. As specified in the General Instructions in Section 1.0 above, all information (including attachments) must be provided in English, be provided in U.S. Dollars and use U. S. credit ratings.

2.3.1 Identification of Equity Participants

2.3.1.1 Who are the **equity participants** in the Project (or the equity partners' other partners)?

2.3.1.2 Provide an **organizational structure** for the Proposer including any general and limited partners and providers of capital that identifies:

- Associated responsibilities from a financial and legal perspective

- Percentage interest of each party

2.3.2 Project Financing

2.3.2.1 **How will the Project be financed** (including construction and term financing)? Address at a minimum:

- The Project's projected financial structure
- Expected source of debt and equity financing

2.3.2.2 [For IPP and Affiliate Proposals] Identify all **estimated development and capital costs** for, at a minimum:

- Equipment
 - Identify the manufacturer and model number for all major equipment
- Construction
- Engineering
- Seller-Owned Interconnection Facilities
- Company-Owned Interconnection Facilities
- Land
- Annual O&M
- Specify a percentage of the total project cost that is estimated to be attributed to the storage functionality of the Facility. As the storage functionality is treated as a lease, the Company will use the percentage for its preliminary calculation of the lease liability only. This percentage requested for the Company's accounting purposes does not affect nor alter the liquidated damage provisions of the PPA, as those provisions reflect the benefit the Company seeks from the Project's storage functionality.

[For Self-Build Only] Identify all **estimated development and capital costs** for, at a minimum:

- Facility (including any generation and storage components)
- Outside Services
- Interconnection
- Overhead Costs
- Allowance for Funds Used During Construction
- Annual O&M
- Specify a percentage of the total project cost that is estimated to be attributed to the storage functionality of the Facility. As the storage functionality is treated as a lease, the Company will use the percentage for its preliminary calculation of the lease liability only. This percentage requested for the Company's accounting purposes does not affect nor alter the liquidated damage provisions of the PPA, as those provisions reflect the benefit the Company seeks from the Project's storage functionality.

2.3.2.3 Discuss and/or provide **supporting information on any project financing guarantees**.

2.3.2.4 Describe any **written commitments obtained from the equity participants**.

2.3.2.5 Describe any **conditions precedent to project financing**, and the Proposer's plan to address them, other than execution of the Power Purchase Agreement or any other applicable project agreements and State of Hawai'i Public Utilities Commission approval of the Power Purchase Agreement and other agreements.

2.3.2.6 Provide any **additional evidence to demonstrate that the Project is financeable**.

2.3.3 Project Financing Experience of the Proposer

Describe **the project financing experience of the Proposer** in securing financing for projects of a similar size (i.e., no less than two-thirds the size) and technology as the one being proposed including the following information for any referenced projects:

- Project Name
- Project Technology
- Project Size
- Location
- Date of Construction and Permanent Financing
- Commercial Operations Date
- Proposer's Role in Financing of the Project
- Off-taker
- Term of the Interconnection Agreement
- Financing Structure
- Major Pricing Terms
- Name(s) of Finance Team Member(s); Time (i.e., years, months) worked on the project and Role/Responsibilities

2.3.4 Evidence of the Proposer's Financial Strength

2.3.4.1 Provide **copies of the Proposer's audited financial statements** (balance sheet, income statement, and statement of cash flows):

- Legal Entity
 - Three (3) most recent fiscal years
 - Quarterly report for the most recent quarter ended
- Parent Company
 - Three (3) most recent fiscal years
 - Quarterly report for the most recent quarter ended

2.3.4.2 Provide the **current credit ratings** for the Proposer (or Parent Company, if not available for Proposer), affiliates, partners, and credit support provider:

- Standard & Poor's
- Moody's
- Fitch

2.3.4.3 Describe any **current credit issues** regarding the Proposer or affiliate entities raised by rating agencies, banks, or accounting firms.

2.3.4.4 Provide any **additional evidence that the Proposer has the financial resources and financial strength** to complete and operate the Project as proposed.

2.3.5 Provide evidence that the Proposer can provide the required securities

2.3.5.1 Describe the Proposer's **ability (and/or the ability of its credit support provider) and proposed plans to provide the required securities** including:

- Irrevocable standby letter of credit
- Sources of security
- Description of its credit support provider

2.3.6 Disclosure of Litigation and Disputes

Disclose any **litigation, disputes, and the status of any lawsuits or dispute resolution** related to projects owned or managed by the Proposer or any of its affiliates

2.4 CONTRACT EXCEPTIONS AND FINANCIAL COMPLIANCE

2.4.1 If Proposers elect to propose modifications to the Model RDG PPA, **provide a Microsoft Word red-line version of the Model RDG PPA** identifying specific proposed modifications to the model language that the Proposer is agreeable to and a detailed explanation and supporting rationale for each modification. General comments, drafting notes, and footnotes such as “parties to discuss” are unacceptable and will be considered non-responsive.

Proposers that do not upload redlines of the applicable RDG PPA with their Proposal submission will be deemed to have accepted the Model RDG PPA in its entirety. If no modifications are proposed, please state in this section “no modifications to the Model RDG PPA”.

As set forth in RFP Section 3.8.5.1, proposed modifications to the RDG PPA will be subject to negotiation between the Company and the Final Award Group and should not be assumed to have been accepted either as a result of being selected to the Final Award Group or based on any previously executed PPA. 2.4.2 State to the best of the Proposer's knowledge: Will the Project result in **consolidation** of the Developer entity's finances onto the Company's financial statements under FASB 810. **Provide supporting information** to allow the Company to verify such conclusion.

2.5 PŪLAMA SITE INFORMATION

2.5.1 Provide a **site layout plan** which illustrates:

- Proposed location of all equipment
- Proposed location of all facilities on the Pūlama Site, including any proposed line extensions
- Site boundaries (if the proposed Project does not cover the entire Pūlama Site)

2.5.2 Describe the **Interconnection route** and include:

- Site sketches of how the facility will be interconnected to the Company's System (above-ground and/or underground)
- Description of the rationale for the interconnection route

2.6 ENVIRONMENTAL REVIEW, PERMITTING PLAN, ENVIRONMENTAL COMPLIANCE/IMPACTS

Scoring of proposals for the 2.6 Environmental Review, Permitting Plan, and Environmental Compliance/Impacts non-price evaluation criteria will be based on the completeness and thoroughness of responses to each of the criteria listed below. The Company recommends that each Proposal incorporate the list below as an outline together with complete and thorough responses to each item in the list. Proposals that closely follow this recommendation will typically be awarded higher scores than proposals that do not.

2.6.1 Describe your **overall land use and environmental permits and approvals strategy** and approach to obtaining successful, positive results from the agencies and authorities having jurisdiction, including:

- Explanation of the conceptual plans for siting
- Studies/assessments
- Permits and approvals
- Gantt format schedule which identifies the sequencing of permit application and approval activities and critical path. (Schedule must be in MM/DD/YY format.)

2.6.2 Discuss the **City Zoning and State Land Use Classification**:

- Identify present and required zoning and the ability to site the proposed Project within those zoning allowances.
- Identify present and required land use classifications and the ability to site the proposed Project within those classifications.
- Provide evidence of proper zoning and land use classifications for selected site and interconnection route.
- If changes in the above are required for the proposed Project, provide a plan and timeline to secure the necessary approvals.

2.6.3 Identify all required discretionary and non-discretionary **land use, environmental and construction permits, and approvals** required for development, financing, construction, and operation of the proposed Project, including but not limited to zoning changes, Environmental Assessments, and/or Environmental Impacts Statements.

Provide a **listing of such permits and approvals** indicating:

- Permit Name
- Federal, State, or Local agencies and authorities having jurisdiction over the issuance
- Status of approval and anticipated timeline for seeking and receiving the required permit and/or license
- Explanation of your basis for the assumed timeline
- Explain any situation where a permit or license for one aspect of the Project may influence the timing or permit of another aspect (e.g., a case where one permit is contingent upon completion of another permit or license), if applicable.
- Explain your plans to secure all permits and approvals required for the Project.

2.6.4 Provide a **preliminary environmental assessment of the site** (including any pre-existing environmental conditions) and potential short- and long-term **impacts** associated with, or resulting from, the

proposed Project – including direct, indirect, and cumulative impacts associated with development, construction, operation, and maintenance of the proposed Project in every area identified below. Discuss if alternatives have been or will be considered. The assessment shall also include Proposer’s short- and long-term plans to mitigate such impacts and explanation of the mitigation strategies for, but not limited to, each of the major environmental areas as presented below:

- Natural Environment
 - Air quality
 - Biology (Natural habitats and ecosystems, flora/fauna/vegetation, and animals, especially if threatened or endangered)
 - Climate
 - Soils
 - Topography and geology
- Land Regulation
 - Land Uses, including any land use restrictions and/or pre-existing environmental conditions/contamination
 - Flood and tsunami hazards
 - Noise
 - Roadways and Road and Air Traffic
 - Utilities
- Socio-Economic Characteristics
- Aesthetic/Visual Resources and Impact
- Solid Waste
- Hazardous Materials
- Water Quality
- Public Safety Services (Police, Fire, Emergency Medical Services)
- Recreation
- Potential Cumulative and Secondary Impacts

2.6.5 Provide a **decommissioning plan**, including:

- Developing and implementing program for recycling to the fullest extent possible, or otherwise properly disposing of installed infrastructure, if any, and
- Demonstrating how restoration of the Site to its original ecological condition is guaranteed in the event of default by the Proposer in the applicable Site Control documentation.

2.7 CULTURAL RESOURCE IMPACTS

2.7.1 Provide a **plan to address the below requirements** as they pertain to the Project Site and interconnection route including the status of any consultant/s with expertise in this field that have been identified and/or contracted with, and documentation of any assessments or work that has been planned or performed to date. Identify any cultural, historical or natural resources in the area in question. For any impacts identified to the categories listed below, provide a mitigation strategy and the expected impact on the Project schedule. Detail the potential impacts of the Proposal on cultural resources in the short- and long-term and the Proposer’s plan to mitigate such impacts. Proposers must provide as much information as possible to allow the Company to understand the considerations.

- Archaeological Resources
- Cultural Practices and Resources

2.8 COMMUNITY OUTREACH

Gaining community support is an important part of a Project's viability and success. An effective Community Outreach Plan will call for early meaningful communications with stakeholders and will reflect a deep understanding and respect for the community's desire for information. The public meeting and comment solicitation process described in Section 5.3 of the RFP is intended to support that premise and the Commission's desire to increase bid transparency within the RFP process. When developers neglect to demonstrate transparency and a willingness to engage in early and frequent communication with Hawaii's communities, costly and timely challenges to their projects have resulted. In some instances, projects have failed. Incorporating transparency during the competitive bidding phase may seem unconventional, but it has become an essential community expectation. Developers must share information and work with communities to address concerns through careful listening, thoughtful responsiveness, and a commitment to respect the environmental and cultural values of Hawai'i.

2.8.1 Provide a **detailed Community Outreach Plan** to work with and inform neighboring communities and stakeholders and to provide them timely information during all phases of the Project. The plan shall address, but not be limited to, the following items:

- Project description
- Community scoping
- Project benefits
- Government approvals
- Development process
- Identification of communities and other stakeholders that may be affected by the proposed Project:
 - How will they be affected?
 - What mitigation strategies will the Proposer implement?
- Comprehensive communication strategy with affected communities and the general public regarding the proposed Project:
 - Describe frequency of communication
 - Provide source of information
 - Identify communication outlets
 - Describe opportunities, if any, for affected communities and general public to provide the developer with feedback and comments on the proposed Project

Proposers are reminded of RFP Section 3.4.2 including Proposals must provide all referenced material if it is to be considered during the Proposal evaluation.

2.8.2 Provide any **documentation of local community support or opposition** including any letters from local organizations, newspaper articles, or communications from local officials.

2.8.3 Provide a **description of community outreach efforts** already taken or currently underway, including the names of organizations and stakeholders contacted about the proposed Project.

2.8.4 Describe any anticipated or negotiated investment in the community and other **community benefits** that the Proposer proposes to provide in connection with the Project, along with an estimated value

of the community benefits in dollars (including the cost to Proposers providing the benefits and supporting details on how those costs and benefits were derived).

2.8.5 Proposer selected to the Final Award Group must provide the below table of information onto their website described in Section 5.3 to provide communities Project information that is of interest to them in a standard format. All information in this table must be included in all community presentations in addition to the Proposer’s project website.

PROJECT SUMMARY AND COMMUNITY OUTREACH PLAN

*	Proposer Name (Company name)	
*	Parent Company/Owner/Sponsor/etc.	
*	Project Name	
*	Net AC Capacity of the Facility (MW) (must match Proposal information)	
*	Project Description (in 200 words or less)	<i>(A description that includes information about the project that will enable the community to understand the impact that the Project might have on the community.)</i>
*	Project site map	<i>(provide a map similar to what was provided in Section 2.5.2)</i>
*	Site layout plan	<i>(provide a layout similar to what was provided in Section 2.5.3)</i>
*	Interconnection route	<i>(provide a map of the route similar to what was provided in Section 2.5.4)</i>
Environmental Compliance, Impacts and Permitting Plan		
*	Overall land use and environmental permits and approvals strategy	<i>(provide information in level of detail as provided in Section 2.6.1)</i>
*	Gantt format schedule which identifies the sequencing of permit applications and approval activities and critical path. Schedule must be in MM/DD/YY format)	<i>(provide information in level of detail as provided in Section 2.6.1)</i>
*	City Zoning and Land Use Classification	<i>(provide information in level of detail as provided in Section 2.6.2)</i>
*	Discretionary and non-discretionary Land use, environmental and construction permits and approvals	<i>(provide information in level of detail as provided in Section 2.6.3)</i>
*	Listing of Permits and approvals	<i>(provide information in level of detail as provided in Section 2.6.3)</i>
*	Preliminary environmental assessment of the site (including any pre-existing environmental conditions)	<i>(provide information in level of detail as provided in Section 2.6.4)</i>
Cultural Resource Impacts		

*	Proposer’s updated Community Outreach Plan must include a plan that (1) identifies any cultural, historic or natural resources that will be impacted by the project (2) describes the potential impacts on these resources and 3) identifies measures to mitigate such impacts.	<i>(provide information in level of detail as provided in Section 2.7)</i>
Community Outreach		
*	Detailed Community Outreach Plan	<i>(provide key information from Community Outreach Plan as specified in Section 2.8.1 or provide a link to updated comprehensive Community Outreach Plan)</i>
*	Local community support or opposition	<i>(provide latest comprehensive information)</i>
*	Community outreach efforts	<i>(provide latest comprehensive information)</i>
*	Community benefits	<i>(provide latest comprehensive information)</i>

2.9 OPERATIONS AND MAINTENANCE (O&M)

2.9.1 To demonstrate the long-term operational viability of the proposed Project, describe the **planned operations and maintenance**, including:

- Operations and maintenance funding levels, annually, throughout the term of the contract.
- Description of the operational requirements by frequency (daily, weekly, monthly, yearly, as-necessary, run hour interval) and maintenance requirements by frequency (daily, weekly, monthly, yearly, as-necessary, run hour interval).
- A discussion of the staffing levels proposed for the Project and location of such staff. If such staff is offsite, describe response time and ability to control the Project remotely.
- Technology specific maintenance experience records.
- Identification of any O&M providers.
- The expected role of the Proposer (Owner) or outside contractor.
- Scheduling of major maintenance activity.
- Plan for testing equipment.
- Estimated life of Generation and/or Storage Facilities and associated Interconnection Facilities.
- Safety plan, including historical safety records with environmental history records, violations, and compliance plans.
- Security plan.
- Site maintenance plan.
- Substation equipment maintenance plan.

2.9.2 State whether the Proposer would **consider 24-hour staffing**. Explain how this would be done.

2.9.3 Describe the **Proposer's contingency plan**, including the Proposer's mitigation plans to address failures. Such information should be described in the Proposal to demonstrate the Project's reliability with regard to potential operational issues.

2.9.4 Describe if the Proposer will **coordinate their maintenance schedule** for the Project with the Company's annual planned generation maintenance. See Article 5 of the model RDG PPA.

2.9.5 Describe the **status of any O&M agreements or contracts** that the Proposer is required to secure. Include a discussion of the Proposer's plan for securing a long-term O&M contract.

2.9.6 Provide **examples of the Proposer's experience** with O&M services for other similar projects.

2.10 PERFORMANCE STANDARDS

2.10.1 Design and operating information. Provide a **description of the project design**. Description shall include:

- Configuration description, including conceptual or schematic diagrams. Overview of the Facility Control Systems – central control and inverter- or resource-level control.
- Diagrams approved by a Professional Electrical Engineer registered in the State of Hawai'i, indicated by the presence of the Engineer's Professional seal on all drawings and documents. Including but not limited to:
 - A single-line diagram, relay list, trip scheme and settings of the generating facility, which identifies the Point of Interconnection, circuit breakers, relays, switches, synchronizing equipment, monitoring equipment, and control and protective devices and schemes.

2.10.1.1 Provide the projected **hourly annual energy potential production profile of the Facility**³ (24 hours x 365 days, 8760 generation profile) for the provided RFP NEP Projection.

2.10.1.2 Provide the **sample rate of critical telemetry** (i.e., frequency and voltage) based on inputs to the facility control systems.

2.10.1.3 Provide a description of the Facility's **capability to be grid-forming and have black-start capability**.

2.10.2 **Capability of Meeting Performance Standards.** The proposed Facility must meet the performance attributes identified in Section 2.1 of the RFP. Provide **confirmation that the proposed Facility will meet the requirements identified** or provide clarification or comments about the Facility's ability to meet the performance standards. Proposals should include sufficient documentation to support the stated claim that the Facility will be able to meet the Performance Standards. The Proposal should include information required to make such a determination in an organized manner to ensure this evaluation can be completed within the evaluation review period.

2.10.3 **Reactive Power Control:** Provide the facility's **ability to meet the Reactive Power Control capabilities**, including Voltage Regulation at the point of interconnection, required in the Performance

³ The projected hourly annual energy production profile is the projected output from the generating facility without curtailment and before any energy is directed to an energy storage component.

Standards, including contribution from the inverters of generation and/or storage and means of coordinating the response. Provide the inverter capability curve(s). Confirm ability to provide reactive power at zero active power.

2.10.4 **Ramp Rate** for Generation Facilities: Confirm the ability to meet the ramp rate requirement specified in the Model PPA.

2.10.5 **Undervoltage ride-through:** Provide the facility's terminal voltage level(s) and elapsed time at which the facility will disconnect from the utility system during the disturbance, if any. Confirm the ability to meet ride-through requirements and include supporting documentation regarding inverter design, control parameters, etc.

2.10.6 **Overvoltage ride-through:** Provide the facility's terminal voltage level(s) and elapsed time at which the facility will disconnect from the utility system during the disturbance, if any. Confirm the ability to meet ride-through requirements and include supporting documentation regarding inverter design, control parameters, etc.

2.10.7 **Transient stability ride-through:** Provide the facility's ability to stay online (# of cycles) during Company System in the following 2 conditions: (1) three-phase fault located anywhere on the Company System and lasting up to __ cycles; and (2) a single line to ground fault located anywhere on the Company System and lasting up to __ cycles. Provide the Facility's ability to withstand subsequent events.

2.10.8 **Underfrequency ride-through:** Provide the facility's terminal frequency level(s) and elapsed time at which the facility will disconnect from the utility system during the disturbance, if any. Confirm the ability to meet ride-through requirements and include supporting documentation regarding inverter design, control parameters, etc.

2.10.9 **Overfrequency ride-through:** Provide the facility's terminal frequency level(s) and elapsed time at which the facility will disconnect from the utility system during the disturbance, if any. Confirm the ability to meet ride-through requirements and include supporting documentation regarding inverter design, control parameters, etc.

2.10.10 **Frequency Response:** Provide the facility's frequency response characteristics as required by the Model PPA, including time of response, tunable parameters, alternate frequency response modes, and means of implementing such features.

2.10.11 **Auxiliary Power Information:** Proposer must provide the maximum auxiliary power requirements for:

- Start-up
- Normal Operations (from generator)
- Normal Operating Shutdown
- Forced Emergency Shutdown
- Maintenance Outage

2.10.12 **Coordination of Operations:** Provide a description of the control facilities required to coordinate generator operation with and between the Company's System Operator and the Company's System.

- Include a description of the equipment and technology used to facilitate dispatch to the Company and communicate with the Company.
- Include a description of the control and protection requirements of the generator and the Company's System.

2.10.13 **Cycling Capability:** Describe the Facility's ability to cycle on/off and provide limitations.

2.10.14 **Active Power Control Interface:** Describe the means of implementing active power control and the Power Possible, including the contribution to the dispatch signal from paired storage, if any. Provide the Proposer's **experience** dealing with active power control, dispatch, frequency response, and ride-through.

2.10.15 Provide the details of the **major equipment** (i.e., batteries, inverters, battery management system), including, but not limited to, name of manufacturer, models, key metrics, characteristics of the equipment, and performance specifications.

2.10.16 **Energy Storage performance standards:** Provide additional performance standard descriptions as follows:

- MWh storage output for a full year
- Ramp Rate: Provide the Facility's ramp rate, which should be no more than 2 MW/minute for all conditions other than those under control of the Company System Operator and/or those due to desired frequency response.
- System Response Time – Idle to Design Maximum (minutes)
- Discharge Start-up time (minutes from notification)
- Charge Start-up time (minutes from notification)
- Start and run-time limitations, if any
- Ancillary Services provided, if any (i.e., Spinning Reserves, Non-Spinning Reserves, Regulation Up, Regulation Down, Black Start capability, other)

2.10.17 Provide the description and details of the **grid-charging capabilities of the Facility**. Include a description on the ability to control the charging source.

2.11 INTERCONNECTION REQUIREMENT STUDY

2.11.1 Provide the completed **Interconnection Requirement Study Data Request form** for the proposed technology with the Proposal submission. (The form can be found in the "1. Download Documents" tab as Appx B Att 2 Project Interconnection Data Request Form (PV Generation) MS Excel file.) Also provide all **project single line diagram(s)** with the Proposal submission. **Models for equipment and controls, list(s)** identifying components and **respective files** (for inverters and power plant controller), and **complete documentation with instructions** shall be submitted within the timeframes specified in Section 5.1 of the RFP. Proposers may also download the PSCAD model requirements memo labelled as Appx B Att 3 from the "1. Download Documents" tab.

2.12 PROVEN TECHNOLOGY

2.12.1 Provide all supporting information for the Company to assess the **commercial and financial maturity of the technology** being proposed. Provide any supporting documentation that shows examples of projects that:

- Use the technology at the scale being proposed
- Have successfully reached commercial operations (for example, by submitting a PPA)
- Demonstrate experience in providing Active Power dispatch

2.13 EXPERIENCE AND QUALIFICATIONS

Proposers, its affiliated companies, partners, and/or contractors and consultants are required to demonstrate project experience and management capability to successfully develop and operate the proposed Project.

2.13.1 Provide an **organizational chart** for the Project that lists the project participants and identifies the management structure and responsibilities. In addition to the organizational chart, Proposers must provide a completed table:

- For each of the project participants (including the Proposer, partners, and proposed contractors), fill out the table below and provide statements that list the specific experience of the firm in: financing, designing, constructing, interconnecting, owning, operating, and maintaining renewable energy generating or storage facilities, or other projects of similar size and technology, and
- Provide any evidence that the project participants have worked jointly on other projects.

EXPERIENCE:							
In the applicable columns below, include project details (i.e., project name, location, technology, size) and relevant job duties (role/responsibilities) and time (in years/months) spent on the project. List multiple projects if applicable.							
Participant Name:	Financing	Designing	Constructing	Interconnecting	Owning	Operating	Maintaining
1.							
2.							
3.							
...							

2.13.2 Identify those **member(s) of the team** the Proposer is submitting to meet the experience Threshold Requirement and demonstrate the member(s) firm commitment to provide services to the Proposer.

2.13.3 Identify those **members of the team with experience and qualifications**, including affiliates, and their principal personnel who will be involved in the project contracting to sell and deliver energy. If the Proposer consists of multiple parties, such as joint ventures or partnerships, provide this information for each party, clearly indicating the proposed role of each party, including an ownership chart indicating direct and indirect ownership, and percentage interests in the partnership or joint venture.

2.13.4 Provide a **management chart** which lists the key personnel dedicated to this Project and provide **biographies / resumes** of the key personnel, including position, years of relevant experience, and similar

project experience. Provide specifics as they relate to financing of renewable energy projects. Identify architects and engineers or provision to provide same that are licensed to practice in the State of Hawai‘i.

2.13.5 Provide a **listing in the table format below, of all renewable energy generation or energy storage projects** the Proposer has successfully developed or that are currently under construction. Describe the Proposer’s role and responsibilities associated with these projects (lead developer, owner, investor, etc.). Provide the following information as part of the response:

Project Name	Location (City, State)	Technology (wind, PV, hydro, plus storage, etc.)	Size (MW/ MWh)	Commercial Operation Date	Offtaker (if applicable)	Role & Responsibilities
1.						
2.						
3.						
...						

2.14 PROJECT SCHEDULE

2.14.1 Provide a **project schedule in GANTT chart format** with complete **critical path activities** identified for the Proposal from the Notice of Selection of the Proposal to the start of Commercial Operations.

- The **schedule** must include:
 - Interconnection Requirement Study (IRS) assumptions
 - Anticipated contract negotiation period assumptions
 - Regulatory assumptions
 - Anticipated submittal and approval dates for permitting (including but not limited to environmental and archaeological compliance)
 - Cultural Resource implications and mitigation activities
 - Community outreach and engagement activities
 - Energy resource assessment
 - Financing
 - Engineering
 - Procurement
 - Facility construction including construction management events
 - Applicable reporting milestone events specified in the Model PPA
 - Testing
 - Interconnection (including engineering, procurement, and construction)
 - Commercial Operations Date
 - All other important elements outside of the direct construction of the Project
- For each project element, list the start and end date (must be in MM/DD/YY format), and include predecessors to clearly illustrate schedule dependencies and durations.
- Proposers must also list and describe critical path activities and milestone events, particularly as they relate to the integration and coordination of the project components and the Company’s Electric System. Proposers must ensure that the schedule provided in this section is consistent with the milestone events contained in the PPA and/or other agreements.

- 2.14.2 Describe the **construction execution strategy** including:
- Identification of contracting/subcontracting plans
 - Modular construction
 - Safety plans⁴
 - Quality control and assurance plan
 - Labor availability
 - Likely manufacturing sites and procurement plans
 - Similar projects where these construction methods have been used by the Proposer.

2.14.3 Provide a description of any **project activities that have been performed to date**.

2.14.4 Explain how you plan to reach **safe harbor milestones** (if applicable) and **guaranteed commercial operations**, including durations and dependencies which support this achievement.

3.0 PROPOSED CBRE PROGRAM

Provide a detailed description of the CBRE program that will be offered to eligible subscribers, including at a minimum, but not limited to, a discussion of the following:

- Financing Options
 - Subscriber fees and payments
 - Upfront payments
 - Ongoing payments
 - Public funding options
 - Extent to which subscribers will be financially responsible for any facility underperformance
- Percentage of the project's capacity that will be available to subscribers vs. unsubscribed capacity
 - Commitments to residential Subscribers
 - Commitments to Low- and Moderate- Income Customers ("LMI Customers")
- Marketing or outreach plans to advertise the proposed project/program to LMI (if applicable) and non-LMI eligible customers
- Strategies for LMI (if applicable) and non-LMI customer retention and maintaining LMI (if applicable) and non-LMI customer participation levels
- Estimated benefits to LMI (if applicable) and non-LMI customer participants
 - Expected savings
 - Payback periods
 - Payback mechanisms
 - Other benefits
- Prior experience, specifically relating to community-based renewable energy projects
- Plans for CBRE program administration

⁴ A document that describes the various safety procedures and practices that will be implemented on the Project and how applicable safety regulations, standards, and work practices will be enforced on the Project.

Appendix B Attachment 1

**Certification of Counsel for Proposer
Hawaiian Electric Company, Inc., Maui Electric Company, Ltd, and Hawai'i Electric Light
Company, Inc.**

Pursuant to Section 1.7.4 of Hawaiian Electric Company, Inc., Hawai'i Electric Light Company, Inc. and Maui Electric Company, Limited's (each a "Company" and collectively, the "Companies") Request For Proposals for Variable Renewable Dispatchable Generation Paired with Energy Storage and Community-Based Renewable Energy, Island of Lāna'i ("RFP"), the Companies may require legal counsel who represent multiple unaffiliated proposers to sign a certification that they have not shared confidential information obtained through the representation of one proposer with any other unaffiliated proposer.

Accordingly, by signing below, I hereby acknowledge, agree and certify that:

(1) in connection with the RFP, I represent the following company that has submitted a proposal(s) for the RFP: _____ ("Proposer");

(2) irrespective of any proposer's direction, waiver or request to the contrary, I will not share a proposer's confidential information or the Company's confidential information associated with such proposer, including, but not limited to, a proposer's or Company's negotiating positions, with third parties unaffiliated with Proposer (by contract or organizational structure), including other proposers responding to the RFP;

(3) the Companies may rely on this certification for purposes of the RFP; and

(4) at the conclusion of power purchase agreement negotiations, if any, the Company may require me to sign a certificate certifying that I have not shared a proposer's confidential information or the Company's confidential information associated with such proposer, including, but not limited to, a proposer's or Company's negotiating positions, with third parties unaffiliated with Proposer (by contract or organizational structure), including other proposers responding to the RFP.

Name (print)

Law Firm (if applicable)

Signature

Date

Section 1.7.4 of the RFP provides in relevant part that:

In submitting a Proposal in response to this RFP, each Proposer certifies that the Proposal has been submitted in good faith and without fraud or collusion with any other unaffiliated person or entity. The Proposer shall acknowledge this in the Response Package submitted with its Proposal. Furthermore, in executing the NDA provided as Appendix E, the Proposer agrees on behalf of its Representatives (as defined in the NDA) that the Company's negotiating positions will not be shared with other Proposers or their respective Representatives.

In addition, in submitting a Proposal, a Proposer will be required to provide Company with its legal counsel's written certification in the form attached as Appendix B Attachment 1 certifying in relevant part that irrespective of any proposer's direction, waiver, or request to the contrary, that the attorney will not share a proposer's confidential information associated with such Proposer with others, including, but not limited to, such information such as a Proposer's or Company's negotiating positions. If legal counsel represents multiple unaffiliated proposers whose

Appendix B Attachment 1

Proposals are selected for the Final Award Group, such counsel will also be required to submit a similar certification at the conclusion of power purchase agreement negotiations that he or she has not shared a proposer's confidential information or the Company's confidential information associated with such Proposer with others, including but not limited to, such information as a Proposer's or Company's negotiating positions.

Appendix B Attachment 2

**Project Interconnection - Data Request
 FOR PV GENERATION**

Updated 7/13/2020

PROJECT: _____

DATE: _____

(Nonexclusive Preliminary List)

***ALL ITEMS ARE REQUIRED AND ALL RESPONSES MUST BE FILLED UNLESS NOT APPLICABLE.

	Response
1) Please provide a plan map of the Renewable Generation facility. Please indicate the interconnection point to the HECO system.	
2) Please provide the following generation and load information for the Renewable Generation facility	
a. Gross and net output of the facility	
b. Expected KW and KVAR loads including, but not limited to, generators' auxiliary load curve, process load(s) profile(s), etc.	
c. Expected minimum and maximum MW and MVAR "import from" AND "export to" HECO.	
3) Please provide Single-Line Diagram(s), Three-Line Diagram(s), and Protective Relay List & Trip Schedule for the generation and interconnection facilities	
a. The Single-line diagram s and Three-line diagram s should include:	
i. For main and generator step up transformer s, please show:	
• Transformer voltage and MVA ratings.	
• Transformer impedance(s).	
• Transformer winding connections and grounding. If neutrals are grounded through impedance, please show the impedance value.	
ii. The protective relaying and metering for the generators, transformers, buses, and all other main substation equipment.	
iii. For the potential transformers, please indicate the type, quantity, ratio, and accuracy rating.	
iv. For the current transformers, please indicate the type, quantity, ratio, and accuracy rating, and thermal rating factor.	
v. Auxiliary power devices e.g. capacitors, reactors, storage systems, etc. and their rating(s); additional inquiries may be made to obtain technical data for these devices.	
vi. For the interconnection / tie lines (overhead or underground) and the plant's generation system, please provide the following, as applicable:	
• Installation details such as cross-section(s), plan and profiles, etc.	
• Conductor data such as size, insulation, length etc.	
• Continuous and emergency current ratings.	
• Voltage rating nominal and maximum KV.	
• BIL rating.	
• Positive, negative, and zero-sequence impedances (resistance, reactance, and susceptance)	
• Capacitance or charging current.	
• Short-circuit current capability.	
vii. Include station power for facility and all applicable details.	
viii. All applicable notes pertaining to the design and operation of the facility.	
b. The Protective relay list trip schedule should list the protected equipment; the relay description, type, style number, quantity, ANSI Device No., and range; and the breaker s /switching device(s) tripped, for both the generator protection and the interconnection facilities protection.	
c. Please provide both a paper and an electronic version (e.g. dgn, dxf, or pdf) of the single-line diagram s and the protective relay list trip schedule.	
d. Single-line diagrams should be provided for both the generation plant and the interconnection substation.	

Appendix B Attachment 2

**Project Interconnection - Data Request
 FOR PV GENERATION**

Updated 7/13/2020

PROJECT: _____

DATE: _____

(Nonexclusive Preliminary List)

***ALL ITEMS ARE REQUIRED AND ALL RESPONSES MUST BE FILLED UNLESS NOT APPLICABLE.

	Response
4) For the PV Inverter Based Generating Facility, please provide the following data	
a. Inverter manufacturer, Type, Size, Impedances. Attach copy of inverter data sheet.	
b. Power Factor Range Capability	
c. Inverter Reactive Power Capability Curve	
d. Auxillary loads P, Q, Power Factor	
e. Inverter s Internal Isolation Transformer Grounding Method, if used (i.e. effectively grounded, resonant grounded, low inductance grounded, high-resistance grounded, low-resistance grounded, ungrounded). If the transformer is not solidly grounded, provide the impedance value for the grounding neutral and the impedance for the isolation transformer.	
f. Diagram for Inverter s internal isolation transformer	
g. Switching and service restoration practice	
h. Protection data (voltage ride-through and trip settings, frequency ride-through and trip settings etc.). Include setpoint and clearing time ranges for voltage and frequency settings.	
i. Description of harmonic spectrum of inverter injection (order, magnitude)	
5) Energy Storage System, if applicable	
a. Operation characteristics	
b. Voltage level	
c. Capacity (how long and how much can the battery support)	
d. Deployment strategy/schedule	
e. Energy storage system data sheet	
6) For the PV plant s collector system, please provide the following, as applicable	
a. Conductor data such as size, insulation, etc.	
b. Continuous and emergency current ratings.	
c. Voltage rating (nominal and maximum kV).	
d. B L rating.	
e. Positive, negative, and zero-sequence impedances (resistance, reactance, and susceptance).	
f. Capacitance or charging current.	
g. Short-circuit current capability.	

Appendix B Attachment 2

**Project Interconnection - Data Request
FOR PV GENERATION**

Updated 7/13/2020

PROJECT: _____

DATE: _____

(Nonexclusive Preliminary List)

***ALL ITEMS ARE REQUIRED AND ALL RESPONSES MUST BE FILLED UNLESS NOT APPLICABLE.

	Response
7) Please provide the following software models that accurately represent the Facility For model requirements, refer to the HECO Facility Technical Model Requirements and Review Process and PSCAD Model Requirements Rev.9)	
a. Validated PSS/E load flow model up to the point of interconnection. The PSS/E model shall include the main transformer, collection system, generator step-up transformers, inverter systems, and any other components including capacitor banks, energy storage systems, DVAR, etc. An equivalent representation of the collection system, generator step-up transformers, and inverter systems is acceptable. Documentation on the model shall be provided.	
b. Validated PSS/E dynamic model for the inverter; and other components including energy storage system, DVAR, etc. if applicable. The inverter model shall include the generator/converter, electrical controls, plant-level controller, and protection relays. Generic and Detailed models shall be provided. Documentation on the model(s) shall be provided, including the PSS/E dyre file with model parameters.	
i. Generic models shall parameterize models available within the PSS/E standard model library.	
ii. Detailed models shall be supplied by the vendor/manufacturer as user-written models. The uncompiled source code for the user-written model shall be provided to ensure compatability with future versions of PSS/E. In lieu of the uncompiled source code, a compiled object file and applicable library files shall be provided in PSS/E versions 33 AND 34 format. Updates of the object file compatible with future PSS/E versions must be provided as requested for the life of the project as written in the power purchase agreement. Documentation shall include the characteristics of the model, including block diagrams, values, names for all model parameters, and a list of all state variables.	
c. Validated PSCAD model of the inverter; and other components including energy storage system, DVAR, auxiliary plant controllers, etc. if applicable. Documentation on the model s shall be provided. Refer to PSCAD Model Requirements Memo for model requirements.	
d. Overlaid plots validating the performance of the three dynamic models for a three-phase fault. Plots shall include voltage, real and reactive power, real and reactive current.	
e. Validated Aspen Oneliner short circuit model that accurately represents the facility including energy storage system if applicable), and is valid for all faults conditions anywhere on the Utility system. Documentation on the model(s) shall be provided. (OTHERWISE SEE ADDITIONAL TABS FOR REQUIRED NFORMATION TO MODEL INVERTER AS A GENERATOR OR A VOLTAGE CONTROLLED CURRENT SOURCE	
8) For the main transformer and generator step-up transformers, please provide	
a. Transformer voltage and MVA ratings, and available taps. Attach copy of transformer test report or data sheet	
b. The tap settings used.	
c. The LTC Control Scheme.	
d. Transformer winding connections and grounding used. If the transformer is not solidly grounded, provide the impedance value for the grounding method.	
e. Positive, negative, and zero sequence impedance values.	
9) For the circuit breakers and fault-clearing switching devices, including the generator breakers, please provide	
a. The voltage, continuous current and interrupting capability ratings.	
b. The trip speed (time to open).	

Appendix B Attachment 2

**Project Interconnection - Data Request
 FOR PV GENERATION**

Updated 7/13/2020

PROJECT: _____

DATE: _____

(Nonexclusive Preliminary List)

*****ALL ITEMS ARE REQUIRED AND ALL RESPONSES MUST BE FILLED UNLESS NOT APPLICABLE.**

		Response
10)	For the power fuses, please provide	
	a. The manufacturer, type, size, and interrupting capability.	
	b. The minimum melt and total clearing curves.	
11)	For the protective relaying, please provide	
	a. Data for the CTs used with the relaying including the manufacturer, type of CT, accuracy class, and thermal rating factor.	
	b. Data for the PTs used with the relaying including the manufacturer, type of PT, voltage ratings, and quantity.	

Updated 7/13/2020

Appendix B Attachment 2

Instructions:

Please fill in the data in the green blanks below

(Note: This does not include the internal isolation transformer, if used)

[1] Maximum rated output power = kVA

[2] Impedances in **Per Unit** based on kVA from [1]

	R	X
Subtransient =	<input type="text"/>	<input type="text"/>
Transient =	<input type="text"/>	<input type="text"/>
Synchronous =	<input type="text"/>	<input type="text"/>
Negative Sequence =	<input type="text"/>	<input type="text"/>
Zero Sequence =	<input type="text"/>	<input type="text"/>

[3] Neutral impedance (if any) in actual Ohms:

R	X
<input type="text"/>	<input type="text"/>

NOTE: These parameters should reflect the inverter response for all types of faults at any point on the electrical system to which the inverter is connected. This includes faults at the inverter output terminals, and also on the 138 kV transmission system. If the stated parameters do not cover this range, please state the adjustments needed to these parameters to accurately represent the inverter response across this range.

These parameters will be used to model the inverter in the Aspen Oneliner program as shown in the sample dialog box below:

Generating Unit Info

ID= Unit rating= MVA

Impedances (pu based on unit MVA)

Subtransient	<input type="text" value="0.1"/>	+j	<input type="text" value="0.1"/>	<input type="button" value="Fill"/>
Transient	<input type="text" value="0.1"/>	+j	<input type="text" value="0.1"/>	
Synchronous	<input type="text" value="0.1"/>	+j	<input type="text" value="0.1"/>	
- sequence	<input type="text" value="0.15"/>	+j	<input type="text" value="0.15"/>	
o sequence	<input type="text" value="9999.0"/>	+j	<input type="text" value="9999.0"/>	

Neutral Impedance (in actual Ohms)

<input type="text" value="0.0"/>	+j	<input type="text" value="0.0"/>
----------------------------------	----	----------------------------------

Scheduled generation. Enter MVAR for PQ buses only

MW= <input type="text" value="0.0"/>	MVAR= <input type="text" value="0.0"/>
--------------------------------------	--

P and Q limits (MW and MVAR)

Pmax= <input type="text" value="9999.0"/>	Qmax= <input type="text" value="9999.0"/>
Pmin= <input type="text" value="-9999.0"/>	Qmin= <input type="text" value="-9999.0"/>

Instructions:

Please fill in the data in the green blanks below

- [1] Internal open circuit voltage
Magnitude = Per Unit
Angle = Degrees
- [2] AC Output Current Limit = Amps

NOTE: These parameters should reflect the inverter response for all types of faults at any point on the electrical system to which the inverter is connected. This includes faults at the inverter output terminals, and also on the 138 kV transmission system. If the stated parameters do not cover this range, please state the adjustments needed to these parameters to accurately represent the inverter response across this range.

These parameters will be used to model the inverter in the Aspen Oneliner program as shown in the sample dialog box below:

Generator Data

Generators at 200 INVERTER 0.2kV

Unit 1' On-Line

Edit
On/Off-Line
New
Delete

Internal V-Source
p.u. = 1
Ref. angle = 0

Current Limits (A)
A: 900 B: 0

Power Flow Regulation
 Regulates voltage Fixed P+jQ output

Memo:

Tags: None

Done Help

Last changed Apr 18, 2010

Updated 7/13/2020

Appendix B Attachment 2

Instructions:

Please fill in the data in the green blanks below

- [1] Inverter MVA Rating: MVA
- [2] Voltage-Current Characteristics:
- | Voltage PU | Current (A) | PF Angle (deg) |
|----------------------|----------------------|----------------------|
| <input type="text"/> | <input type="text"/> | <input type="text"/> |
| <input type="text"/> | <input type="text"/> | <input type="text"/> |
| <input type="text"/> | <input type="text"/> | <input type="text"/> |
| <input type="text"/> | <input type="text"/> | <input type="text"/> |
- [3] Location of Voltage Measurement:
- Device Terminal OR
 Network side of Transformer
- [4] Maximum Voltage: Times prefault value
- [5] Minimum Voltage Per Unit

These parameters will be used to model the inverter in the Aspen Oneliner program as shown in the sample dialog box below:

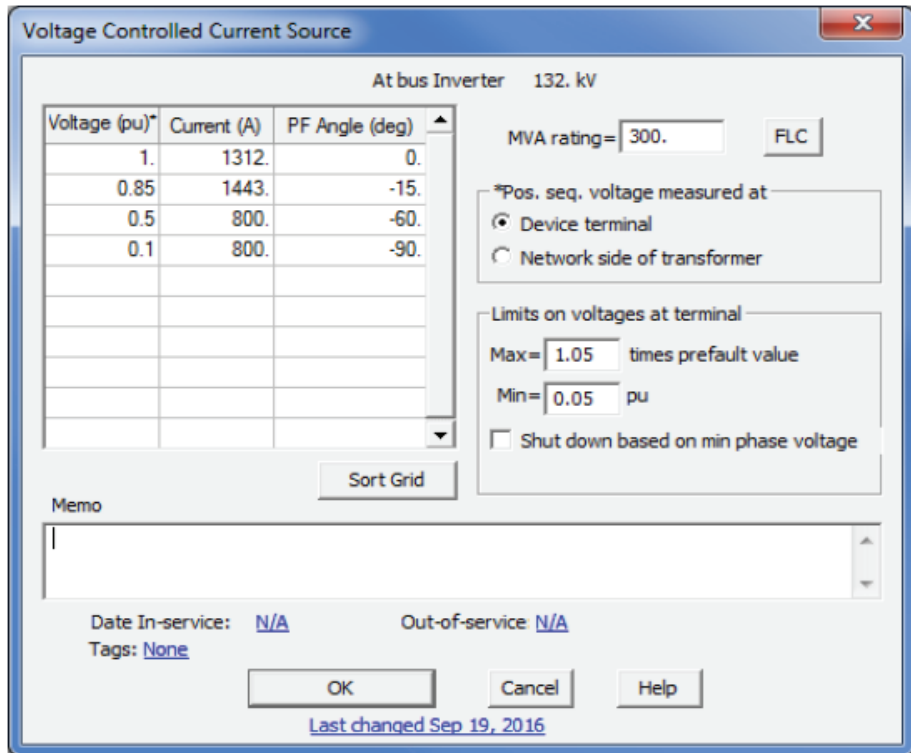

Updated 7/13/2020

Appendix B Attachment 2

Instructions:

Please fill in the data in the green blanks below

(Note: This is not required if an internal isolation transformer is not used)

[1] Transformer rated power = kVA

[2] Winding Configuration
 Inverter Side = Delta/Wye
 Customer Side = Delta/Wye

[2] Impedances in **Per Unit** based on kVA

	R	X
Positive Sequence =	<input style="width: 100%; height: 20px;" type="text"/>	
Zero Sequence =		

[3] Neutral impedance (if any) in actual **Ohms**:

R	X
<input style="width: 100%; height: 20px;" type="text"/>	

These parameters will be used to model the inverter in the Aspen Oneliner program as shown in the sample dialog box below:

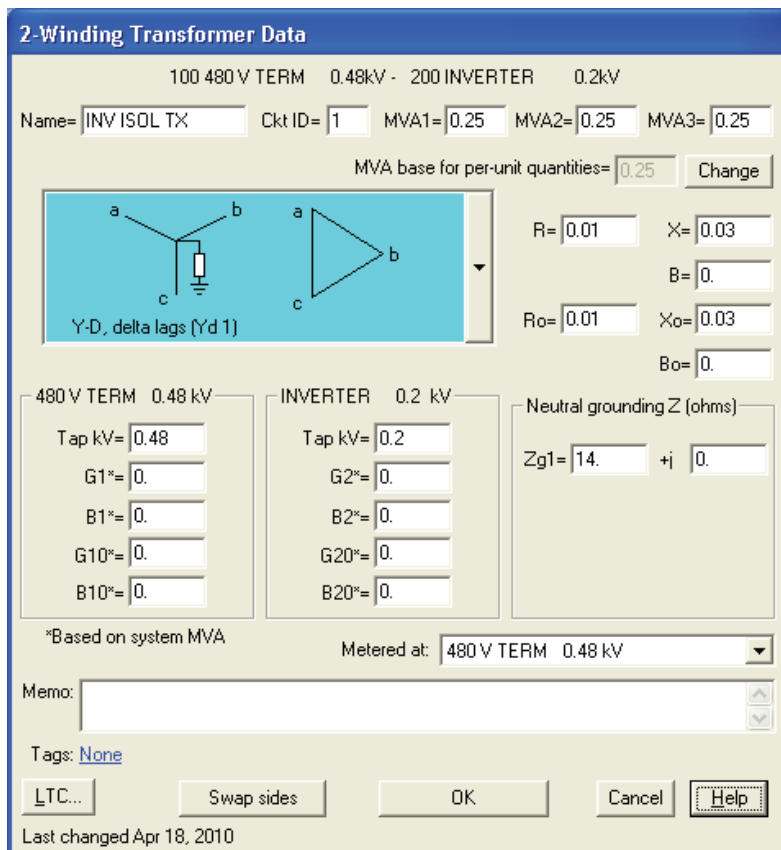

Appendix B Attachment 3

HECO FACILITY TECHNICAL MODEL REQUIREMENTS AND REVIEW PROCESS

March 17, 2020

Table of Contents

FACILITY TECHNICAL MODEL REQUIREMENTS AND REVIEW PROCESS.....	0
1 INTRODUCTION	1
2 FACILITY TECHNICAL MODEL REQUIREMENTS.....	2
2.1 General requirements for all technical models	2
2.2 Requirements for generation facility PSCAD model	3
2.3 Requirements for generation facility generic PSS/E power flow model	3
2.4 Requirements for generation facility user defined PSS/E dynamic model	3
2.5 Requirements for generation facility user defined PSS/E dynamic model	4
2.6 Requirements for generation facility ASPEN model	5
3 GENERATION FACILITY TECHNICAL MODEL REVIEW PROCESS	6
3.1 Model review in PSCAD	6
3.2 Model review in PSS/E.....	6
4 TYPICAL ISSUES IDENTIFIED FROM THE FACILITY MODEL DURING THE PAST RFP PROCESS ...	8
REFERENCE	9
APPENDIX A: SAMPLE OVERLAID GENERATION FACILITY TECHNICAL MODEL OUTPUT PLOT FOR THREE-PHASE FAULT	10
APPENDIX B: SAMPLE TEST SYSTEM EQUIVALMENT IMPEDANCE INFORMATION	12

1 INTRODUCTION

This document summarizes requirements of generation facility technical model submittals for request for proposals for variable renewable dispatchable generation and energy storage and describes the review process for model submittals.

2 FACILITY TECHNICAL MODEL REQUIREMENTS

To fully investigate impacts of the proposed generation facility on Hawaiian Electric's system and correctly identify any mitigation measures, the proposed generation facility technical model, along with related technical documents, will need to be submitted as part of the project interconnection review and prior to the Interconnection Requirements Study (IRS). The generation facility technical model includes:

1. PSCAD model
2. Generic PSS/E power flow model
3. User defined PSS/E dynamic model
4. Generic PSS/E dynamic model, and
5. ASPEN model

Along with the technical models, following documents should also be submitted for review:

6. User manual for all technical models
7. Generation facility one-line diagram
8. Generation unit manufacturer datasheet
9. Generation unit reactive power capability curve
10. Overlaid generation facility technical model output data for three-phase fault and single-phase fault. (Sample plots are shown in Appendix A)

2.1 General requirements for all technical models

All technical models need to represent the whole generation facility, not only a generation unit such as one inverter. At minimum, the following equipment shall be included in the generation facility model:

1. Generation unit, such as inverter with DC side model, rotation machine with model of exciter and governor.
2. Step up transformer
3. Collection system
4. Main interconnection transformer, or GSU, with its tap changer if applicable
5. Grounding transformer
6. Conductor
7. Var compensation device, such as cap bank or STATCOM, if applicable
8. Power plant controller (not for ASPEN model)
9. Documentation
10. Gen-tie line (as applicable)

An equivalent representation of the collection system, generator step-up transformers, and inverter systems is acceptable.

2.2 Requirements for generation facility PSCAD model

In addition to the general requirements mentioned above, the generation facility PSCAD model shall satisfy requirements as described in the document "PSCAD Model Requirements Rev. 9" provided by Hawaiian Electric.

2.3 Requirements for generation facility generic PSS/E power flow model

The generation facility PSS/E power flow model shall be provided for both PSS/E version 33 and version 34. Besides the general requirements mentioned above, the following modeling data shall be provided in the model:

1. Conductor
 - a. Impedance, both positive sequence and zero sequence
 - b. Rating: Rating A – normal rating, and Rating B – emergency rating
2. Transformer
 - a. Nominal voltages of windings
 - b. Impedance data: specified R and X
 - c. Tap ratios
 - d. Min and Max tap position limits
 - e. Number of tap positions
 - f. Regulated bus
 - g. Ratings: Rate A – normal rating; Rate B – emergency rating
 - h. Winding configuration
3. Reactive power compensation, if applicable
 - a. Fixed Shunts: G-Shunt (MW), B-Shunt (MVar)
 - b. Switched Shunts: Voltage limits (V_{hi} and V_{low}), mode of operation (fixed, discrete, continuous), regulated bus, Binit (MVar), steps and step size (MVar)
4. Generation unit
 - a. P_{max}
 - b. P_{min}
 - c. Q_{max}
 - d. Q_{min}
 - e. Name plate MVA
 - f. Transformer data: R_{Tran}, X_{Tran}, and G_{entap}.
 - g. Voltage control point

2.4 Requirements for generation facility user defined PSS/E dynamic model

The submitted user defined PSS/E dynamic model should meet the following requirements:

1. The generation facility PSS/E dynamic model shall be provided for both PSS/E version 33 and version 34.
2. The project shall be modeled at full output per the project's Interconnection Request.
3. User defined dynamic models must accurately model all the relevant control modes and characteristics of the equipment, such as:

Appendix B Attachment 3

- a. All available voltage/reactive power control modes
 - b. Frequency/governor response control modes
 - c. Voltage and frequency ride-through characteristics
 - d. Power plant controller or group supervisory functionality
 - e. Appropriate aggregate modeling capability
 - f. Charging mode if applicable (e.g., for a battery energy storage device)
4. Dynamic model source code (.flx) or dynamic linked library (.dll), and PSS/E dyr file shall be provided.
 5. User defined dynamic model plant-specific settings shall comply with requirements listed in the Power Purchase Agreement, including ride-through thresholds and other specified control settings if applicable.
 6. User defined dynamic models related to individual units shall be editable in the PSS/E graphic user interface. All model parameters (CONS, ICONS, and VARS) shall be accessible and shall match the description in the model's accompanying documentation.
 7. User defined dynamic models shall have all their data reportable in the "DOCU" listing of dynamics model data, including the range of CONS, ICONS, and VARS numbers. Models that apply to multiple elements (e.g., park controllers) shall also be fully formatted and reportable in DOCU.
 8. User defined dynamic models shall be capable of correctly initializing and run through the simulation throughout the range of expected steady state starting conditions without additional manual adjustments.
 9. User defined dynamic models shall be capable of allowing all documented (in the model documentation) modes of operation without error.
 10. User defined dynamic model shall be accompanied by the following documentation:
 - a. A user's guide for each model
 - b. Appropriate procedures and considerations for using the model in dynamic simulations
 - c. Technical description of characteristics of the model
 - d. Block diagram for the model, including overall modular structure and block diagrams of any sub-modules
 - e. List of plant-specific settings, which may include:
 - i. Ride-through thresholds and parameters
 - ii. Plant-level voltage controller settings
 - iii. Power ramp rate settings
 - iv. ICON flag parameters for specific control modes
 - v. Deadbands
 - vi. Initial State of Charge (SOC)
 - f. Values, names and detailed explanation for all model parameters
 - g. List of all state variables, including expected ranges of values for each variable

2.5 Requirements for generation facility generic PSS/E dynamic model

The submitted generic PSS/E dynamic model should meet the following requirements:

1. All generic PSS/E dynamic models must be standard library models in PSS/E.

Appendix B Attachment 3

2. The generation facility PSS/E dynamic model shall be provided for both PSS/E version 33 and version 34.
3. The project shall be modeled at full output per the project's Interconnection Request.
4. Generic dynamic models must accurately model all the relevant control modes and characteristics of the equipment, such as:
 - a. All available voltage/reactive power control modes
 - b. Frequency/governor response control modes
 - c. Voltage and frequency ride-through characteristics
 - d. Power plant controller or group supervisory functionality
 - e. Appropriate aggregate modeling capability
 - f. Charging mode if applicable (e.g., for a battery energy storage device)
5. PSS/E dyr file shall be provided.
6. Generic dynamic models' plant-specific settings should comply with requirements listed in the Power Purchase Agreement, including ride-through thresholds and other specified control settings if applicable.
7. Generic dynamic models shall be capable of correctly initializing and run through the simulation throughout the range of expected steady state starting conditions without additional manual adjustments.
8. Generic dynamic models shall be accompanied by the following documentation:
 - a. A user's guide for each model
 - b. Appropriate procedures and considerations for using the model in dynamic simulations
 - c. Technical description of characteristics of the model
 - d. List of plant-specific settings, which may include:
 - i. Ride-through thresholds and parameters
 - ii. Plant-level voltage controller settings
 - iii. Power ramp rate settings
 - iv. ICON flag parameters for specific control modes
 - v. Deadbands
 - vi. Initial State of Charge (SOC)

2.6 Requirements for generation facility ASPEN model

Besides the general requirements, validation results of single phase and three-phase fault current from the generation unit represented in the generation facility ASPEN model shall be provided.

3 GENERATION FACILITY TECHNICAL MODEL REVIEW PROCESS

To review the generation facility technical model, the following procedures are performed in the PSCAD and PSS/E environment. A review of the results will be documented and provided to the Customer for confirmation of model acceptance or further model updates.

3.1 Model review in PSCAD

- 1) Review model data against “Technical memo PSCAD requirements V5.pdf” provided by Hawaiian Electric. In this step, it will be determined whether the model is complete, generation facility settings are according to the Power Purchase Agreement, and if the model can be compiled and run without any error.
- 2) Initialization test:
In this step, the generation facility PSCAD model will be determined whether the model initialization is acceptable. Hawaiian Electric requires that:
 - a. The PSCAD model shall initialize as quickly as possible (e.g. <1-3 seconds) to user defined terminal conditions.
 - b. Project PSCAD model shall initialize properly and that the same power flow and voltage conditions shall be observed between the PSCAD and PSS/E models after initialization.
- 3) Voltage and frequency ride-through tests:
In this step, the generation facility PSCAD model ride-through performance will be reviewed by performing voltage and frequency ride-through simulations in PSCAD. The review will focus on the generation facility model dynamic response during and after ride-through and generation facility trip time.
- 4) Fault simulation tests:
Two types of fault tested at the Point of Interconnection bus of the generation facility will be performed in this step.
 - i) 3-phase to ground fault with 6-cycle clearing time (same as the PSS/E ring down model test described in the following section).
 - ii) 1-phase to ground fault simulation with 6-cycle clearing time.

In this test, fault current contribution from the generation facility observed in the simulation will be reviewed by comparing it against the generation facility technical document.

3.2 Model review in PSS/E

- 1) Model data review:
Review model data based on the requirements for PSS/E power flow and dynamic model provided by Hawaiian Electric. In this step, the review determines whether the model is complete, generation facility settings is according to the PPA, and model can be compiled and run without any error.
- 2) Flat start test:

Appendix B Attachment 3

PSS/E models shall initialize correctly and be capable of successful “flat start” testing using the 20 Second No-Fault simulation: This test consists of a 20 second simulation with no disturbance applied.

3) Ring down test:

PSS/E models shall initialize correctly and be capable of successful “ring down” testing using the 60 Second Disturbance Simulation: This test consists of the application of a 3-phase fault for 6 cycles at POI bus, followed by removal of the fault without any lines being tripped. The simulation is run for 60 seconds to allow the dynamics to settle.

4) Voltage and frequency ride-through tests:

In this step, the generation facility PSS/E model ride-through performance will be reviewed by performing voltage and frequency ride-through simulation in PSS/E. The review will focus on the generation facility model dynamic response during and after ride-through and generation facility trip time.

4 TYPICAL ISSUES IDENTIFIED FROM THE FACILITY MODEL SUBMITTALS DURING THE PAST RFP PROCESS

1. Missing documentation

Only generation technical facility models are submitted, but no model user manual or any other documentation. Without model documentation, it is very difficult to know the correct procedures of using the technical models and identifying issues during the review.

2. Model incompleteness

Often, the model of a single generation unit, such as an inverter, is submitted instead of model of the whole generation facility, which is insufficient. The model of the generation facility should include models for all equipment listed in the section of "General requirements for all technical models".

3. Settings in the model

Type issues in this category are:

- The PSCAD and PSS/E model ride-through settings are not consistent with the settings defined in the Power Purchase Agreement.
- Generation MW is not set as defined.
- Model is set for 50 Hz instead of 60 Hz

4. Model function issues

Some models do not function as expected during different test scenarios. For example:

- Fault current contribution from the generation facility is higher than what is described in the generation facility datasheet
- Generation level is not stable as settings during the initialization test
- Long time oscillation observed in the ringdown test
- Ride-through performance does not reach requirements defined in the Power Purchase Agreement

REFERENCE

- [1] New England Iso Planning procedure – Interconnection planning procedure for generation and elective transmission upgrades
- [2] ERCOT Planning Guide, 2019
- [3] PJM MOD-032 Steady State, Dynamics, and Short Circuit Modeling Data Requirements and Reporting Procedures Document

APPENDIX A: SAMPLE OVERLAID GENERATION FACILITY TECHNICAL MODEL OUTPUT PLOT FOR THREE-PHASE FAULT

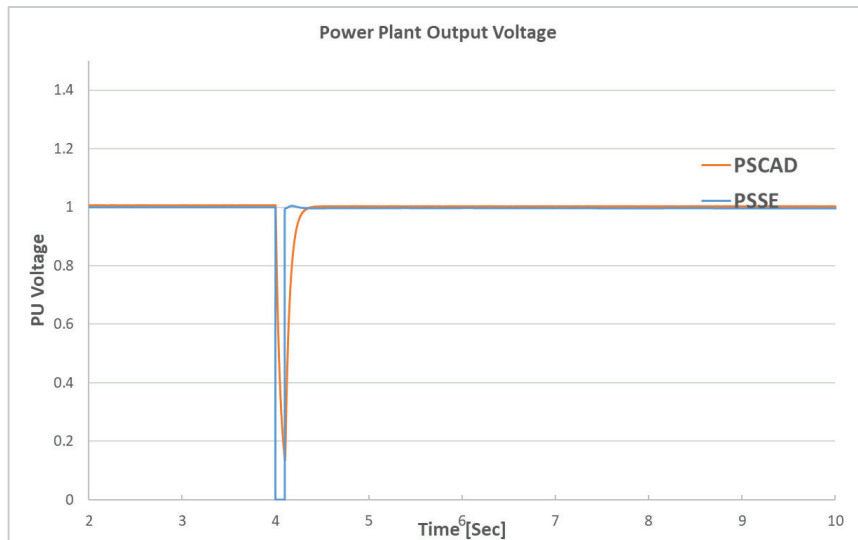

Figure 1: Overlaid plot for power plant voltage

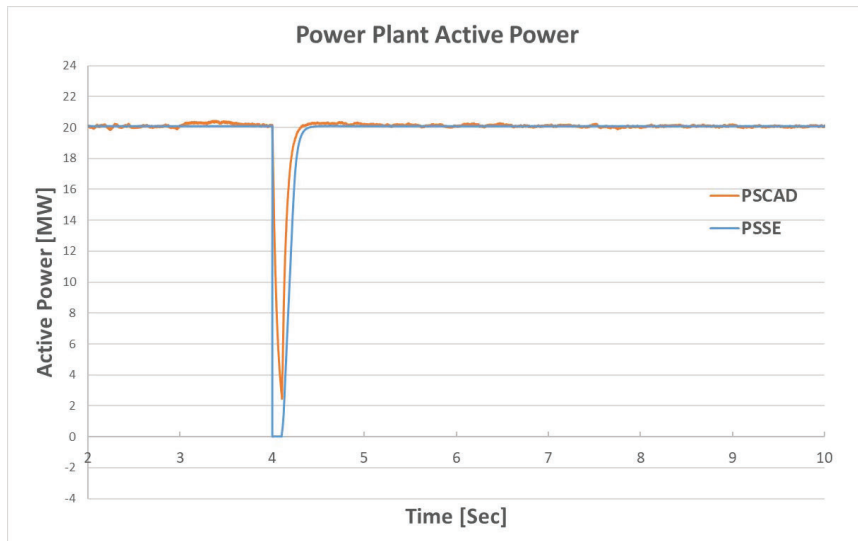

Figure 2: Overlaid plot for power plant active power generation

Appendix B Attachment 3

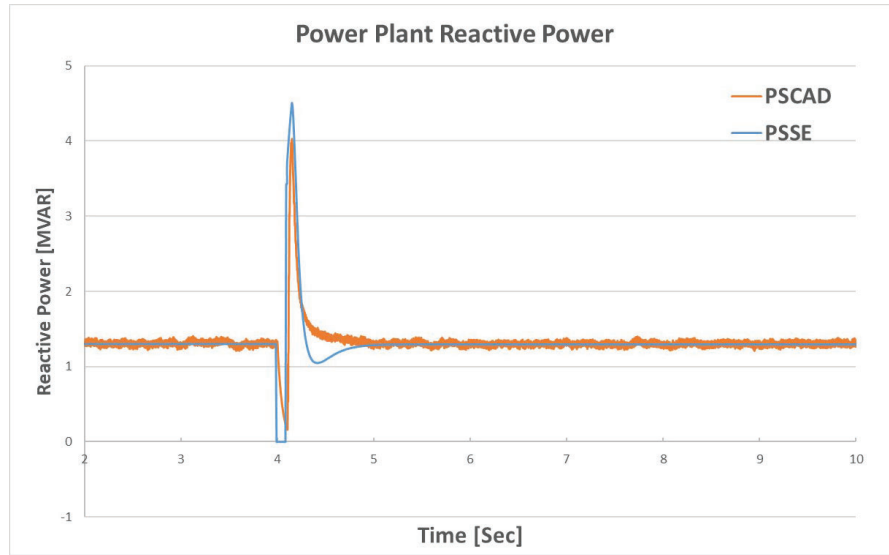

Figure 3: Overlaid plot for power plant reactive power generation

APPENDIX B: SAMPLE TEST SYSTEM TOPOLOGY INFORMATION

On weak grids such as island systems, it is important to test the models using a representative high Thevenin equivalent impedance.

A typical topology of testing circuit which represents Hawaiian Electric system for 46 kV project is shown in Figure 4. Sample 46 kV Thevenin equivalent impedance is available upon request for model testing.

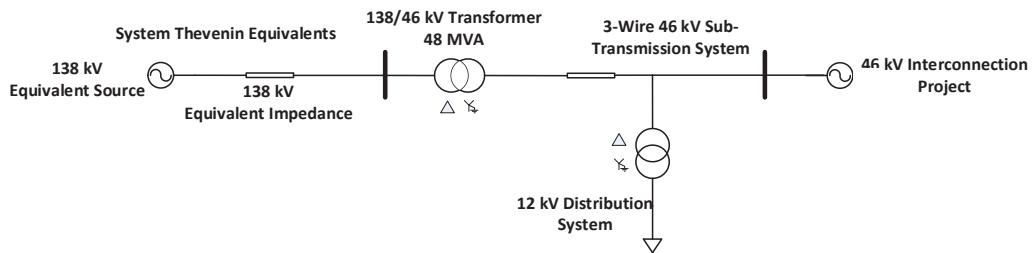

Figure 4: Testing circuit single line diagram for 46 kV project

A typical topology of testing circuit which represents Hawaiian Electric system for 138 kV project is shown in Figure 5. Sample 138 kV Thevenin equivalent impedance is available upon request for model testing.

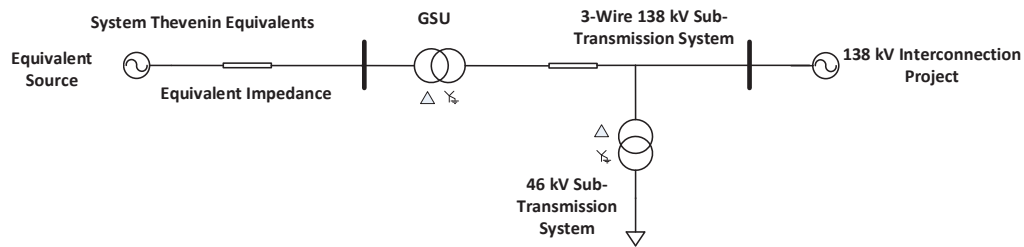

Figure 5: Testing circuit single line diagram for 138 kV project

PSCAD Model Requirements Rev. 9

Date: May 8, 2020
Prepared By: Andrew L. Isaacs
Lukas Unruh
Garth Irwin

This document includes the following attachments:

Attachment #1: PSCAD Model Test Checklist

Attachment #2: PSCAD Model Requirements Supplier Checklist

Electranix makes no representations or warranties of any kind concerning this document, whether express, implied, statutory, or other. This includes, without limitation, warranties of title, merchantability, fitness for a particular purpose, non-infringement, absence of latent or other defects, accuracy, or the presence or absence of errors, whether or not known or discoverable. Electranix will not be held liable for any direct, special, indirect, incidental, consequential, punitive, exemplary, or other losses, costs, expenses, or damages arising out of use of this document or any material herein, even if Electranix has been advised of the possibility of such losses, costs, expenses, or damages.

Copyright PSCAD Model Requirements Supplier Checklist © 2020 by Electranix Corporation. Please contact info@electranix.com for information regarding use or modification of this document.

12-75 Scurfield Blvd.
Winnipeg, MB, Canada, R3Y 1P6
www.electranix.com



This work is licensed under the Creative Commons Attribution 4.0 International License. To view a copy of this license, visit <http://creativecommons.org/licenses/by/4.0/> or send a letter to Creative Commons, PO Box 1866, Mountain View, CA 94042, USA.

Introduction

Specific model requirements for a PSCAD study depend on the type of study being done. A study with a scope covering weak system interconnections, ride-through evaluation, short term¹ event response, and fast control interaction with nearby devices (for example) would require a model which has the following characteristics. Some specialty studies may require other features. Refer to “Attachment #1: PSCAD Model Test Checklist” and “Attachment #2: PSCAD Model Requirements Supplier Checklist”, appended to this document, for additional information on how these requirements may applied.

Model Accuracy Features

For the model to be sufficiently accurate, it must:

- A. *Represent the full detailed inner control loops of the power electronics.* The model cannot use the same approximations classically used in transient stability modeling, and should fully represent all fast inner controls, as implemented in the real equipment. Models which embed the actual hardware code into a PSCAD component are currently wide-spread, and this is the recommended type of model.²
- B. *Represent all control features pertinent to the type of study being done.* Examples include external voltage controllers, plant level controllers, customized PLLs, ride-through controllers, SSCI damping controllers and others. As in point A, actual hardware code is recommended to be used for most control and protection features. Operating modes that require system specific adjustment should be user accessible. Plant level voltage control should be represented along with adjustable droop characteristics. If multiple plants are controlled by a common controller, this functionality should be included.
- C. *Represent all pertinent electrical and mechanical configurations.* This includes any filters and specialized transformers. There may be other mechanical features such as gearboxes, pitch controllers, or others which should be modelled if they impact electrical performance within the timeframe of the study. Any control or dynamic features of the actual equipment which may influence behaviour in the simulation period which are not represented or which are approximated should be clearly identified.

¹ Example analysis periods could be 2 to 10 seconds from fault inception. Some studies could require longer periods.

² The model must be a full IGBT representation (preferred), or may use a voltage source representation that approximates the IGBT switching but maintains full detail in the controls. A three phase sinusoidal source representation is not acceptable. Models manually translated block-by-block from MATLAB or control block diagrams may be unacceptable because the method used to model the electrical network and interface to the controls may not be accurate, or portions of the controls such as PLL circuits or protection circuits may be approximated or omitted. Note that firmware code may be directly used to create an extremely accurate PSCAD model of the controls. The controller source code may be compiled into DLLs or binaries if the source code is unavailable due to confidentiality restrictions.

It is not recommended to assemble the model using standard blocks available in the PSCAD master library, as approximations are usually introduced, and specific implementation details for important control blocks may be lost. In addition, there is a significant risk that errors will be introduced in the process of manually assembling the model. For this type of manually assembled model, (not using a direct “real code” embedding process), extra care is required, and validation is required.

- D. *Have all pertinent protections modeled in detail for both balanced and unbalanced fault conditions.* Typically this includes various OV and UV protections (individual phase and RMS), frequency protections, DC bus voltage protections, converter overcurrent protections, and often other inverter specific protections. As in point A, actual hardware code is recommended to be used for these protection features.
- E. *Be configured to match expected site-specific equipment settings.* Any user-tunable parameters or options should be set in the model to match the equipment at the specific site being evaluated, as far as they are known. Default parameters may not be appropriate.

Model Usability Features

In order to allow study engineers to perform system analysis using the model, the PSCAD model must:

- F. *Have control or hardware options which are pertinent to the study accessible to the user.* Examples of this could include protection thresholds, real power recovery ramp rates, or SSCI damping controllers.³ Diagnostic flags (eg. flags to show control mode changes or which protection has been activated) should be visible to aid in analysis.
- G. *Be accurate when running at a simulation time step of 10 μ s or higher.* Often, requiring a smaller time step means that the control implementation has not used the interpolation features of PSCAD, or is using inappropriate interfacing between the model and the larger network. Lack of interpolation support introduces inaccuracies into the model at larger simulation time-steps. In cases where the IGBT switching frequency is so high that even interpolation does not allow accurate switching representation at 10 μ s (eg. 40 kHz), an average source approximation of the inverter switching may be used to allow a larger simulation time step².
- H. *Operate at a range of simulation time steps.* The model should not be restricted to operating at a single time step, but should be able to operate within a range (eg. 10 μ s – 20 μ s)
- I. *Have the ability to disable protection models.* Many studies result in inadvertent tripping of converter equipment, and the ability to disable protection functions temporarily provides study engineers with valuable system diagnostic information.
- J. *Include documentation and a sample implementation test case.* Test case models should be configured according to the site-specific real equipment configuration up to the Point of Interconnection. This would include (for example): aggregated generator model, aggregated generator transformer, equivalent collector branch, main step up transformers, gen tie line, and any other static or dynamic reactive resources. Test case should use a single machine infinite bus representation of the system, configured with an appropriate representative SCR, such as 2.5. Access to technical support engineers is desirable.
- K. *Have an identification mechanism for configuration.* The model documentation should provide a clear way to identify the specific settings and equipment configuration which will be used in any

³ Care should be taken to ensure that any user-settable options are not changed in a way that is not implementable in the real hardware, and that any selectable options are actually available at the specific site being considered. Discussion is recommended with the manufacturer prior to any changes being made in model configuration.

- study, such that during commissioning the settings used in the studies can be checked. This may be control revision codes, settings files, or a combination of these and other identification measures.
- L. *Accept external reference variables.* This includes real and reactive power ordered values for Q control modes, or voltage reference values for voltage control modes. Model should accept these reference variables for initialization, and be capable of changing these reference variables mid-simulation, ie. dynamic signal references.
 - M. *Be capable of initializing itself.* Once provided with initial condition variables, the model must initialize and ramp to the ordered output without external input from simulation engineers. Any slower control functions which are included (such as switched shunt controllers or power plant controllers) should also accept initial condition variables if required.
 - N. *Have the ability to scale plant capacity.* The active power capacity of the model should be scalable in some way, either internally or through an external scaling transformer⁴. This is distinct from a dispatchable power order, and is used for modeling different capacities of plant or breaking a lumped equivalent plant into smaller composite models.
 - O. *Have the ability to dispatch its output to values less than nameplate.* This is distinct from scaling a plant from one unit to more than one, and is used for testing plant behaviour at various operating points.
 - P. *Initialize quickly.* Model must reach its ordered initial conditions as quickly as possible (for example <5 seconds) to user supplied terminal conditions.

Study Efficiency Features

In addition, the following elements are required to improve study efficiency, model compatibility, and enable other studies which include the model to be run as efficiently as possible. If these features are not supported, additional discussion is required⁵:

- Q. Model should be compatible with Intel Fortran compiler version 12 and higher.
- R. Model should be compatible with PSCAD version 4.5.3 and higher.
- S. Model supports multiple instances of its own definition in the same simulation case.
- T. Model supports the PSCAD “timed snapshot” feature accessible through project settings.
- U. Model supports the PSCAD “multiple run” feature.
- V. Model does not use or rely upon global variables in the PSCAD environment.
- W. Model should not utilize multiple layers in the PSCAD environment, including ‘disabled’ layers.

⁴ A free publicly available scaling transformer suitable for this purpose is available in the E-Tran library.

⁵ Electrenix has parallelization tools available (E-Tran Plus for PSCAD) which can circumvent compatibility concerns in some cases.

Attachment #1: PSCAD Model Test Checklist

Electranix makes no representations or warranties of any kind concerning this document, whether express, implied, statutory, or other. This includes, without limitation, warranties of title, merchantability, fitness for a particular purpose, non-infringement, absence of latent or other defects, accuracy, or the presence or absence of errors, whether or not known or discoverable. Electranix will not be held liable for any direct, special, indirect, incidental, consequential, punitive, exemplary, or other losses, costs, expenses, or damages arising out of use of this document or any material herein, even if Electranix has been advised of the possibility of such losses, costs, expenses, or damages.

Copyright PSCAD Model Requirements Supplier Checklist © 2020 by Electranix Corporation. Please contact info@electranix.com for information regarding use or modification of this document.

Purpose

This document is a test checklist meant to accompany “PSCAD Model Requirements Rev. 9” provided above and “Attachment #2: PSCAD Model Requirements Supplier Checklist”. The procedures provided in this document are intended to provide an indication of the core model accuracy, performance, and usability features specified in the model requirements. These procedures cannot ultimately prove that the model is compliant with all requirements, as black box models usually hide the details of the equipment controls and protection. It is recommended that the equipment manufacturer supply additional confirmation that the model meets each individual requirement. The requirements in this document do not necessarily represent interconnection criteria for specific individual systems, and may be supplemented or adjusted based on interconnection region.

The tests outlined here are considered “basic”, and may be supplemented by more rigorous testing, including various fault types, depths, and durations, as well as more extensive protection testing and benchmarking against phasor models. This document is not intended to be a guide for thorough benchmarking between PSCAD, PSS/E, and actual equipment, and is subject to revision as the state of the art in EMT modeling evolves.

<i>Model test Summary</i>	
Model Test date:	
Project Name:	
Manufacturer:	
Equipment type: (eg. PV or Wind)	
Equipment version:	
Documentation file:	
Model Files supplied:	

Verification Procedure and Checklist

		Pass/Fail	Comments
<i>Vendor and site specific model verification</i>			
1a	The Vendor's name and the specific version of the model should be clearly observable in the .psc model file.		
1b	Documentation and supporting model filenames should not conflict with model version shown in the .psc model file.		
1c	Model is supplied with a test circuit which is configured for the site specific application. ⁶		
<i>"Real Code" model verification</i>			
2a	Controls are black-boxed, and no PSCAD master library control blocks are visible within control circuits. ⁷ If the model is not based on "real code", a separate validation report is required showing model comparison against hardware tests. ⁸		
<i>Model usability verification</i>			
3a	Model uses a timestep greater than 10 μs ⁹		
3b	Model allows a variation in simulation timestep		
3c	Model compiles using Intel FORTRAN version 12		
3d	Model initializes in 5 seconds or less with a POI level SCR of 2.5. Real power, reactive power, and RMS voltage should reach steady state by this time.		
3e	Model allows multiple instances of itself to be run together in the same case ¹⁰		
<i>Model electrical configuration verification</i>			
4a	Plant level electrical single line diagram (SLD) is included.		

⁶ The test circuit should model all relevant electrical components of the plant and contain a system equivalent. Parameters will be assumed to be site-specific, unless there are obvious indications otherwise, such as an incorrect grid base frequency.

⁷ Black-boxing of controls to a high level does not guarantee that real-code is embedded into the model, however the visibility of PSCAD master-library control blocks in the inner control loops (PLL, inner current controllers, etc.) suggest that the model is generic in nature. Model documentation may contain information on use of real-code in the model.

⁸ All aspects of the controller operation are required to be validated by utilizing a "hardware in loop" platform or other hardware test systems. Model should not be validated against other software models. Validations should include control responses to various types of faults, changes in power and voltage references, changes in system frequency, testing frequency response in sub and super-synchronous ranges, and testing of protection operation. Tests should also be performed under a variety of system strengths, including very weak systems. Other tests may also be required. The validation report is required along with any model updates that result from the more rigorous validation tests.

⁹ Models with timesteps less than 10 μs may be acceptable in situations where a small timestep does not significantly increase the runtime of the total simulation

¹⁰ Depending on specific application and whether E-Tran Plus for PSCAD is allowed to be used to overcome the limitation, this requirement may be waived.

4b	Generator step-up transformer(s) included, with impedance between 5 and 10% on generator base, and matches SLD. ¹¹		
4c	Lumped collector equivalent(s) included, with total charging equal to between 0.5 and 5% of plant rating, and matches SLD. ¹¹		
4d	Substation transformer(s) included, rated appropriately for plant size, and impedance between 6 and 12% on transformer base, and matches SLD. ¹¹		
4e	Model can be scaled to represent any number inverters/turbines, either using a scaling transformer or internal scaling.		
4f	All external devices included in the plant (such as STATCOMs) include appropriate models.		
<i>Plant controller verification</i>			
5a	Model includes power plant controller (PPC)		
5b	PPC accepts an external active power setpoint.		
5c	PPC accepts a voltage setpoint.		
5d	PPC has a mechanism to implement a settable voltage droop.		
5e	Overall plant responds to frequency changes by increasing or decreasing its active power as appropriate. This may be accomplished either at an inverter level or via the PPC. ¹²		
5f	Model initializes to the setpoints specified in the PPC. If droops or deadbands are utilized, the initial values may differ from the setpoints. ¹³		
5g	If external voltage control devices (STATCOM/DVAR, SVC, MSCs) are included in the plant, ensure that the voltage control of these devices is coordinated with the PPC, with no potential for VAR looping or oscillations.		
<i>Basic performance verification¹⁴</i>			
6a	Instantaneous voltage and current waveforms have minimal distortion, and no oscillations are observed.		

¹¹ Impedance range is for sanity checking only. Impedances outside this range may be allowed.

¹² Non-compliance with this item may not require model revision as frequency response may not be required in PSCAD models by some utilities. In this case, a description of the under/over frequency response capabilities of the actual equipment should be provided by the manufacturer.

¹³ If voltage control with droop is implemented, it is preferred that the PPC model requests an initial Q value to match the voltage setpoint. If no initial Q is requested, the voltage setpoint can be biased by the initial Q before it is sent to the PPC. If a non-zero deadband is included in the voltage controller, the deadband can also be considered in the voltage setpoint sent to the PPC.

¹⁴ Performance testing is recommended with a POI level SCR of 2.5 as this is a representative system condition seen during weak system studies. Testing may be performed at higher SCRs if the stable operating SCR of a model is known to be above 2.5.

**PSCAD Model Requirements Rev. 9
May 8, 2020**



6b	Model is able to ride-through and recover from a temporary (no line outage or drop in SCR), 6-cycle, zero-impedance, three-phase fault at the high side of the station transformer, with a POI level SCR of 2.5.		
6c	Model responds to a step change in PPC voltage setpoint, reaching 90% of the new value between 1 and 10 seconds in a test system with POI level SCR of 2.5. (Various systems may have specific speed requirements, which should be met)		
6d	Model responds to a step change in PPC active power setpoint, reaching 90% of the new value between 1 and 10 seconds in a test system with POI level SCR of 2.5. ¹⁵		
<i>Basic protection verification</i> ¹⁶			
7a	Protection settings are implemented. These could be available as inputs in the model, or hard-coded in the black-boxed controls. ¹⁷		
7b	Option to disable protection models is present. ¹⁸		
7c	Model trips or blocks when terminal voltage rises above 1.3 pu for 1.5 second. ¹⁹		
7d	Model trips or blocks when terminal voltage falls below 0.2 pu for 1.5 second. ¹⁹		
7e	Model clearly displays trip / diagnostic signals indicating the status of all pertinent protection elements		
<i>Documentation</i>			
8a	Model documentation states compliance with "PSCAD Model Requirements Rev. 9 Rev. 9" ²⁰ , or is supplied with a completed PSCAD Model Requirements Supplier Checklist.		
8b	Model documentation includes instructions for setup and running of the model, including the recommended range of simulation timesteps. Documentation should give a clear description of trip / operation code signals produced by model.		

¹⁵ Different response time criteria may apply depending on specific interconnection region.

¹⁶ There are many protection functions which should be modelled, per footnote 1, and these basic tests will not be proof that these are modelled.

¹⁷ If settings are not visible in model or documentation, verification that protection settings are implemented in the PSCAD model should be received from the manufacturer.

¹⁸ Non-compliance may not require model revision as many studies do not require testing with protection settings disabled.

¹⁹ Non-compliance with this item should result in verification of protection settings implementation from the manufacturer, as some models may have capabilities beyond what is listed here.

²⁰ Non-compliance may be waived in systems which do not require compliance with the model requirements document.

Attachment #2: PSCAD Model Requirements Supplier Checklist

Electranix makes no representations or warranties of any kind concerning this document, whether express, implied, statutory, or other. This includes, without limitation, warranties of title, merchantability, fitness for a particular purpose, non-infringement, absence of latent or other defects, accuracy, or the presence or absence of errors, whether or not known or discoverable. Electranix will not be held liable for any direct, special, indirect, incidental, consequential, punitive, exemplary, or other losses, costs, expenses, or damages arising out of use of this document or any material herein, even if Electranix has been advised of the possibility of such losses, costs, expenses, or damages.

Copyright PSCAD Model Requirements Supplier Checklist © 2020 by Electranix Corporation. Please contact info@electranix.com for information regarding use or modification of this document.

Purpose

This document is a model requirements checklist which should be completed by the supplier of the model and submitted alongside each PSCAD model. This document accompanies the “PSCAD Model Requirements Rev. 9” document above (PMR), which should be used for further reference to describe the requirements associated with each point. Generic testing of the model may be done using “Attachment #1: PSCAD Model Test Checklist”, which may be used as a reference.

Model supplier must review every item in the checklist and indicate compliance for each item. If the supplied model does not meet any of the requirements an explanation of the deficiency should be provided in the comments column.

<i>Model Submission Summary (to be completed by model supplier)</i>	
Submission date:	
Project Name:	
Primary contact information for model related questions:	
Secondary contact information for model related questions:	
Manufacturer:	
Equipment type: (eg. PV or Wind)	
Equipment version:	
Documentation file(s):	
Model Files supplied:	

Model Requirements Checklist				Model Complies? (Yes/No)	Comments
1	<i>Model Accuracy Features</i>				
1.1	Power electronic controls are modelled by interfacing with actual firmware code from the inverter (“real code” model), or includes detailed validation report.	A, B			
1.2	Operating modes which require system specific adjustment are accessible.	B			
1.3	Plant level controller is included. ²¹	B			
1.4	Model is capable of controlling frequency ²²	B			
1.5	Includes pertinent electrical and mechanical features, such as gearboxes, pitch controllers, or other features which impact the plant performance in the simulation period. ²³	C			
1.6	All protections which could impact ride-through performance are modelled in detail.	D			
1.7	Model is configured for the specific site being evaluated, as far as they are known.	E			
2	<i>Model and Project Documentation</i>				
2.1	Model includes documentation.	J			
2.2	Documentation includes instruction for setup and running the model.	J			

²¹ If the plant is part of a multi-plant control scheme, a description of the overall scheme should be provided, and corresponding PPC models should be configured to control multiple plants accordingly.

²² Frequency control model requirements may vary by region. Example response time may be less than 10 seconds.

²³ Simulation period may vary depending on the model use, but 10 seconds of simulation following an event such as a fault is a typical period.



**Recommended PSCAD Model Requirements Rev. 9
May 8, 2020**

2.3	Model is supplied with a sample test case including site specific plant representation.	J	
2.4	Plant single line diagram is provided, and aligns with model	J	
2.5	Model documentation provides a clear way to identify site-specific settings and equipment configuration.	K	
3	<i>Model Usability Features</i>		
3.01	Control or hardware options are accessible to the user as applicable.	F	
3.02	Diagnostic flags are visible to the user.	F	
3.03	Model uses a timestep greater than 10 μ s.	G	
3.04	Model allows a range of simulation timesteps (ie. not restricted to a single timestep).	H	
3.05	Protection model may be disabled for troubleshooting	I	
3.06	Model accepts external reference variables for active and reactive power and voltage setpoint, and these may be changed dynamically during the simulation.	L	
3.07	Model is capable of initializing itself.	M	
3.08	Active power capacity is scalable.	N	
3.09	Active power is dispatchable.	O	
3.10	Model reaches setpoint P, Q, and V in 5 seconds or less	P	
3.11	Model compatible with Intel FORTRAN version 12 and higher.	Q	
3.12	Model compiles using PSCAD version 4.5.3 or higher.	R	
3.13	Model supports multiple instances of its own definition in a single PSCAD case.	S	
3.14	Model supports PSCAD "snapshot" feature.	T	

This work is licensed under the Creative Commons Attribution 4.0 International License. To view a copy of this license, visit <http://creativecommons.org/licenses/by/4.0/> or send a letter to Creative Commons, PO Box 1866, Mountain View, CA 94042, USA.

**Recommended PSCAD Model Requirements Rev. 9
 May 8, 2020**



3.15	Model supports the PSCAD “multiple run” feature.	U	
3.16	Model does not use PSCAD global variables.	V	
3.17	Model does not use PSCAD layer functionality	W	

This work is licensed under the Creative Commons Attribution 4.0 International License. To view a copy of this license, visit <http://creativecommons.org/licenses/by/4.0/> or send a letter to Creative Commons, PO Box 1866, Mountain View, CA 94042, USA.



Transmission and Distribution Planning Division - Interconnection Services Department
Simulation Tests
CBRE RFP Interconnection Requirement Study-System Impact Study
Date: July 7, 2020

1. Introduction

This document describes the simulation tests that Hawaiian Electric IRS study consultants will perform to check the models submitted for CBRE IRS. Results of these tests, combined with other checks on project input data and model parameters, will determine if the models are acceptable for the IRS studies. The models to be tested are PSS E user-written model, PSCAD model and ASPEN short-circuit model for each project.

It is recommended that the model submitters should also perform these tests to self-check on your models, so that your models will become acceptable for the IRS study in a timely manner.

2. Separate Models Required for Grid Following Mode and Grid Forming Mode

For the CBRE IRS, modeling of inverter Grid Forming capabilities may be required. For each project, separate models should be submitted: one with the project in Grid Forming (GFM) mode (if applicable), and the other with the project in Grid Following (GFL) mode. This requirement applies to all models mentioned above.

3. General Requirements

All submitted models should be accompanied by proper documentation.

There should be a reasonable match between the PSS E user-written model and the PSCAD model responses for the simulation tests performed for both models.

4. List of Simulation Tests

4.1 GFL Mode Simulation Tests

4.1.1 Tests to be performed for PSS E models

- a. Flat run in a two-machine system (one machine is a synchronous machine, e.g., GENCLS model, and the other machine is a project's model.)
- b. Ringdown (3ph-ground fault simulation test) in a two-machine system.



GFL-Tests to be performed for PSS E models - continued

- c. Voltage ride-through and response in a two-machine system.
- d. Frequency ride-through and response in a two-machine system.
- e. Weak grid operation in a two-machine system
Gradually increase/decrease MVA of the synchronous machine within a range and check if the project's model is able to work with the studied MVA range.
- f. Simulation in a relevant HECO island system model for a couple of selected faults
The purpose here is to identify potential issues with a project's PSS E model ahead of dynamic stability analysis to limit study delays due to model issues.

Note: also refer to "Siemens PTI Model Review process_200317.pdf".

4.1.2 Tests to be performed for PSCAD models only (includes model adequacy and documentation checks)

- g. Tests and checks outlined in "PSCAD Requirements Rev 9 May 2020.pdf", inclusive of ringdown, voltage and frequency ride-through tests.



4.2 GFM Mode Simulation Tests

4.2.1 Tests to be performed for both PSS E and PSCAD models

Test notes:

- Applicable for projects which include grid-forming BESS only
- Assumption is that BESS has available energy and is dispatched suitably for the tests (i.e. Not at current limit)

- a. Able to black start and operate in island mode

Test sequence: energize main power transformer from project side, then connect project to a load, then apply a bus fault at the POI, then remove the fault. Results: voltage and frequency should be stable and settle back to close to their nominal values after the disturbances.

- b. Loss of the last synchronous machine

Test system will be a three-machine system including: a synchronous machine modeled by GENROU with a simple excitation system model (e.g., SCRX) and a simple governor model (e.g., TGOV1), a load with both real and reactive components, and duplicates of a project's model. Duplicates of a project's model are utilized here to check if the project is able to share real and reactive power properly with other generators. Test event: trip the synchronous generator. Results: voltage and frequency should be stable and settle back to close to their nominal values after the disturbance.

- c. Weak grid operation

Test system is the two-machine system. Gradually increase/decrease MVA of the synchronous machine within a range and check if the project's model is able to work with the studied MVA range.

- d. Able to operate in harmony with other converter resources and synchronous machines

Test system is the three-machine system including: a synchronous machine modeled by GENROU with a simple excitation system model and a simple governor model, a load with both real and reactive components, and duplicates of a project's model. Simulation tests to be performed may include load step up/down, ringdown, voltage ride through and frequency ride-through tests. Results: voltage and frequency should be stable and settle back to close to their nominal values after the disturbances.



GFM Mode Simulation Tests – Tests to be performed for both PSS E and PSCAD models - continued

Particularly related to frequency control characteristics, we will test for configurable frequency droop control and configurable deadband characteristics. The frequency deadband should be settable in the range from +/- 0.01 Hz to +/- 1.0 Hz and the frequency droop shall be settable in the range of 0.1% to 10% with a typical value of 4%. A sample characteristic of frequency droop control with deadband is shown in Figure 1.

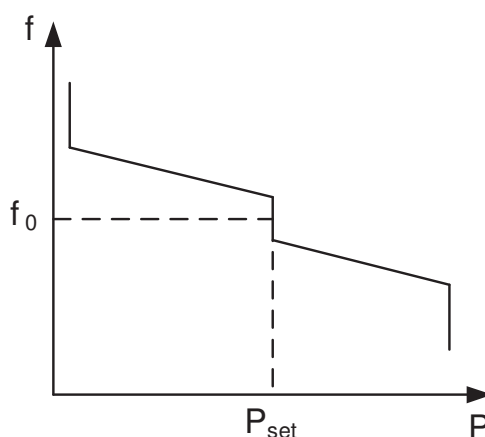

Figure 1 – Frequency Droop Control Characteristic with Deadband

e. Switching between GFL mode and GFM mode

Test system is the two-machine system. Test sequence: energize main power transformer from project side, then connect project to a load. At this point, the project will be operating in island mode, performing frequency control. Then switch in the synchronous generator; the project will be operating in power/frequency droop control mode. Results: voltage and frequency should be stable and settle back to close to their nominal values after the disturbances.

4.2.2 Tests to be performed for PSS E models only

a. Reduction in frequency deviation in GFM mode

Test system will be a relevant HECO island system model. Test event is loss of a large generator. Project model will be in GFL mode and GFM mode. Result: less degree of frequency deviation is expected when project is in GFM mode than when the project is in GFL mode.



4.3 ASPEN Model Check

A review of the ASPEN models will be performed. As mentioned above, two models are expected for each project: one model for GFL mode, and the other for GFM mode. Documentation associated with the models should be provided. The model review will check if the components of a project are modeled properly, such as transformers, equivalent collector system, equivalent generator, etc., and that the model data are consistent to the PSS E and PSCAD model data. A fault simulation test will also be performed in a two-machine system. Total current at the fault location and contribution from each machine will be reviewed and documented.



Siemens Industry, Inc.
Siemens Power Technologies International
 4000 East Third Avenue - Suite 400
 Foster City, CA 94404 USA
 Tel: +1 (650) 772-2289
 www.siemens.com/power-technologies

Date: March 17, 2020

From: Osazuwa Oriakhi, Wenchun Zhu and Kavita Shenoi, Siemens PTI

RE: HECO IRS Model Review Process

Message from Interconnection Services: This document shows you an example of the model data review and tests that a study consultant performs on your model data submittal under the Interconnection Requirement Study, System Impact Study (IRS SIS Agreement). The Test Package that you are receiving is repeated for the IRS. By performing these tests as a Do-it-Yourself (DIY), model data submittals when we receive them for the IRS SIS are understood to be accurate and have usability and efficiency features to integrate the facility model data with the Company's system model data and commence the IRS SIS analyses in a prompt and efficient manner.

Siemens PTI performs the following data checks and tests as a part of our Model review process.

A. Steady State Data Review

Siemens PTI will review the ratings and impedances of all equipment in the ASPEN, PSS®E and PSCAD models and check for discrepancies. Table 1 below shows the comparison of power flow data for all equipment in the PSS®E and PSCAD models.

Table 1. Steady State Data Review

Equipment	Comments
Gen-Tie line	PSS®E, PSCAD and ASPEN models should match
Main Power Transformer Impedance	PSS®E, PSCAD and ASPEN models should match
Main Power Transformer Configuration	PSCAD and ASPEN models should match
PV Collector System Data	PSS®E, PSCAD and ASPEN models should match
BESS Collector System Data	PSS®E, PSCAD and ASPEN models should match
Inverter Pad Mount Transformer Impedance	PSS®E, PSCAD and ASPEN models should match
Inverter Pad Mount Transformer Configuration	PSCAD and ASPEN models should match
Inverter Power Flow Data	PSS®E and PSCAD models should match
Voltage Control Point	PSS®E and PSCAD models should match

This document was prepared by Siemens Industry, Inc., Siemens Power Technologies International (Siemens PTI), solely for the benefit of the recipient named in this memorandum. Siemens PTI nor any party acting on its behalf (a) makes any warranty, expressed or implied, with respect to the use of any information or methods disclosed in this document; or (b) assumes any liability with respect to the use of any information or methods disclosed in this document. Any party other than the named recipient of this memorandum, by their acceptance or use of this document, releases Siemens PTI from any liability for direct, indirect, consequential or special loss or damage whether arising in contract, warranty, express or implied, tort or otherwise, and irrespective of fault, negligence, and strict liability.

B. Dynamic Model Data Review

There are three types of models which show the transient/dynamic behavior of the generation facility:

1. A PSS®E user-written dynamic model which is a detailed model of the specific inverters and controls provided by the manufacturer.
2. A PSS®E generic model which utilizes PSS®E library models to specify the dynamic behavior of the facility.
3. A PSCAD model which is a detailed transient model of the inverters and controls

Siemens PTI will compare the various dynamic model parameters across the three models and note any discrepancies in the data fields shown in Table 2.

Table 2. Comparison of Dynamic Model Parameters

Parameters	Comments
Power Plant Controller (PPC)	Review number of PPCs
Control Flags	PSS®E and PSCAD control flags should match.
Control Bus/Point of Measurement	Control buses should match in PSS®E and PSCAD models.
Frequency Control Dead Band	The frequency thresholds for primary and secondary control should match in the PSCAD and PSS®E models.
Initial State of Charge (SOC)	Make sure the initial state of charge is set up correctly to prevent initialization issues.
Voltage and Frequency Ride Through Settings	The voltage and frequency ride through settings should match in the PSS®E user-written, PSS®E generic and PSCAD models.
P/Q priority data	The P/Q priority flags should match in the PSS®E user-written, PSS®E generic and PSCAD models

C. Model tests

Siemens PTI will perform the following tests to check the active power, reactive power, voltage and frequency responses of the generation facility and review if the three models (PSS®E user-written, PSS®E generic and PSCAD models) show consistent responses.

1. **Flat Run Test:** This is a no-disturbance simulation to check a model's initialization. This test is applicable to all three types of models.
2. **Ring Down Test:** In this simulation, a fault is placed at the facility's POI for a duration of 6-cycles. The fault is subsequently cleared, and the post-disturbance response of the facility is observed. This test is applicable to all three types of models.
3. **High and Low Frequency Response Test:** In these simulations, the system frequency is varied to test the facility's responses to grid's frequency excursions. In the PSS®E tests, high and low frequency excursions are simulated to mimic the frequency ride through thresholds specified in the PPA and the response of the facility is observed. Both the frequency ride-through capability of the facility and its active power response to frequency excursions are tested in the PSS®E simulations.

In the PSCAD simulations, the focus is on testing the facility's active power responses to frequency excursions, and not on testing the frequency ride-through capability. However, it should be noted that the duration of the frequency excursions in the PSCAD tests are well-

Appendix B Attachment 3

within the no-trip zones according to the PPA, and so the facility is not expected to trip during these simulations. Table 3 and Table 4 show the frequency excursions that were simulated in the PSCAD tests.

Table 3 Frequency Excursions for PSCAD High Frequency Response Test

Frequency level (Hz)	Duration (secs)
60.1	2.0
63.0	2.0

Table 4 Frequency Excursions for PSCAD Low Frequency Response Test

Frequency level (Hz)	Duration (secs)
59.9	2.0
56.0	2.0

4. **High and Low Voltage Ride-through and Response Tests:** In these simulations, the POI voltage is varied to test the facility’s ride-through capabilities and responses to POI voltage excursions. In the PSS[®]E simulations, two sets of tests are performed: one for testing the ride-through capabilities and the other for testing the responses to voltage excursions. These two sets of tests are similar, except that the grid equivalent representation is different. For the ride-through tests, the grid equivalent is represented by a generator with a very large MVA, which connects to the POI bus directly. For the voltage excursion response tests, the grid equivalent is represented by a 500 MVA generator which connects to the POI through a branch with a reactance of 0.1 p.u.

In the PSCAD simulations, the focus is on testing the facility’s reactive power responses to POI voltage excursions, and not on testing the voltage ride-through capability. However, it should be noted that the duration of the voltage excursions in the PSCAD tests are well-within the no-trip zones according to the PPA, and so the facility is not expected to trip during these simulations.

Table 5 shows the voltage excursions that will be simulated in the PSCAD tests.

Table 5 POI Voltage Excursions for PSCAD Voltage Response Test

POI Voltage level (pu)	Duration (secs)
1.20	0.8
1.10	2.0
0.88	2.0
0.70	2.0

Each of the above discussed tests were performed for the following three generation dispatches:

- **PV output only:** In this dispatch, the PV unit is at maximum output and the BESS unit is online at 0 MW.
- **BESS output only:** In this dispatch, the BESS unit is discharging at maximum output and the PV unit is online at 0 MW.

Appendix B Attachment 3

- **PV charging BESS:** In this dispatch, the PV unit is at its maximum output and is charging the BESS at its minimum level.

D. Expected Model Performance

1. Matching steady-state model parameters between the PSS®E user-written, generic models and the PSCAD model.
2. Matching control options between the three types of models.
3. Matching voltage and frequency ride-through parameters between the three types of models. The settings should meet the ride-through requirements specified in the PPA.
4. Flat run results do not show any movement for any of the three models.
5. Ring-down simulation results show stable and proper responses, and the responses from the three models should show reasonable matches.
6. Ride-through simulation results should show stable and proper responses, and the responses should show reasonable matches. The ride through performance should meet the PPA requirements.

E. Model Review Reporting Requirements

1. Simulation tests should be performed using the python scripts provided by Siemens PTI, and should be readily reproducible.
2. Discuss model review results.
3. Include simulation plots for the simulation tests discussed above.
4. Related to high and low frequency ride through tests, document frequency response droops shown in the simulations.

PSCAD Model Requirements Rev. 9

Date: May 8, 2020
Prepared By: Andrew L. Isaacs
Lukas Unruh
Garth Irwin

This document includes the following attachments:

Attachment #1: PSCAD Model Test Checklist

Attachment #2: PSCAD Model Requirements Supplier Checklist

Electranix makes no representations or warranties of any kind concerning this document, whether express, implied, statutory, or other. This includes, without limitation, warranties of title, merchantability, fitness for a particular purpose, non-infringement, absence of latent or other defects, accuracy, or the presence or absence of errors, whether or not known or discoverable. Electranix will not be held liable for any direct, special, indirect, incidental, consequential, punitive, exemplary, or other losses, costs, expenses, or damages arising out of use of this document or any material herein, even if Electranix has been advised of the possibility of such losses, costs, expenses, or damages.

Copyright PSCAD Model Requirements Supplier Checklist © 2020 by Electranix Corporation. Please contact info@electranix.com for information regarding use or modification of this document.

12-75 Scurfield Blvd.
Winnipeg, MB, Canada, R3Y 1P6
www.electranix.com

ELECTRANIX
SPECIALISTS IN POWER SYSTEM STUDIES

This work is licensed under the Creative Commons Attribution 4.0 International License. To view a copy of this license, visit <http://creativecommons.org/licenses/by/4.0/> or send a letter to Creative Commons, PO Box 1866, Mountain View, CA 94042, USA.

Introduction

Specific model requirements for a PSCAD study depend on the type of study being done. A study with a scope covering weak system interconnections, ride-through evaluation, short term¹ event response, and fast control interaction with nearby devices (for example) would require a model which has the following characteristics. Some specialty studies may require other features. Refer to “Attachment #1: PSCAD Model Test Checklist” and “Attachment #2: PSCAD Model Requirements Supplier Checklist”, appended to this document, for additional information on how these requirements may applied.

Model Accuracy Features

For the model to be sufficiently accurate, it must:

- A. *Represent the full detailed inner control loops of the power electronics.* The model cannot use the same approximations classically used in transient stability modeling, and should fully represent all fast inner controls, as implemented in the real equipment. Models which embed the actual hardware code into a PSCAD component are currently wide-spread, and this is the recommended type of model.²
- B. *Represent all control features pertinent to the type of study being done.* Examples include external voltage controllers, plant level controllers, customized PLLs, ride-through controllers, SSCI damping controllers and others. As in point A, actual hardware code is recommended to be used for most control and protection features. Operating modes that require system specific adjustment should be user accessible. Plant level voltage control should be represented along with adjustable droop characteristics. If multiple plants are controlled by a common controller, this functionality should be included.
- C. *Represent all pertinent electrical and mechanical configurations.* This includes any filters and specialized transformers. There may be other mechanical features such as gearboxes, pitch controllers, or others which should be modelled if they impact electrical performance within the timeframe of the study. Any control or dynamic features of the actual equipment which may influence behaviour in the simulation period which are not represented or which are approximated should be clearly identified.

¹ Example analysis periods could be 2 to 10 seconds from fault inception. Some studies could require longer periods.

² The model must be a full IGBT representation (preferred), or may use a voltage source representation that approximates the IGBT switching but maintains full detail in the controls. A three phase sinusoidal source representation is not acceptable. Models manually translated block-by-block from MATLAB or control block diagrams may be unacceptable because the method used to model the electrical network and interface to the controls may not be accurate, or portions of the controls such as PLL circuits or protection circuits may be approximated or omitted. Note that firmware code may be directly used to create an extremely accurate PSCAD model of the controls. The controller source code may be compiled into DLLs or binaries if the source code is unavailable due to confidentiality restrictions.

It is not recommended to assemble the model using standard blocks available in the PSCAD master library, as approximations are usually introduced, and specific implementation details for important control blocks may be lost. In addition, there is a significant risk that errors will be introduced in the process of manually assembling the model. For this type of manually assembled model, (not using a direct “real code” embedding process), extra care is required, and validation is required.

- D. *Have all pertinent protections modeled in detail for both balanced and unbalanced fault conditions.* Typically this includes various OV and UV protections (individual phase and RMS), frequency protections, DC bus voltage protections, converter overcurrent protections, and often other inverter specific protections. As in point A, actual hardware code is recommended to be used for these protection features.
- E. *Be configured to match expected site-specific equipment settings.* Any user-tunable parameters or options should be set in the model to match the equipment at the specific site being evaluated, as far as they are known. Default parameters may not be appropriate.

Model Usability Features

In order to allow study engineers to perform system analysis using the model, the PSCAD model must:

- F. *Have control or hardware options which are pertinent to the study accessible to the user.* Examples of this could include protection thresholds, real power recovery ramp rates, or SSCI damping controllers.³ Diagnostic flags (eg. flags to show control mode changes or which protection has been activated) should be visible to aid in analysis.
- G. *Be accurate when running at a simulation time step of 10 μ s or higher.* Often, requiring a smaller time step means that the control implementation has not used the interpolation features of PSCAD, or is using inappropriate interfacing between the model and the larger network. Lack of interpolation support introduces inaccuracies into the model at larger simulation time-steps. In cases where the IGBT switching frequency is so high that even interpolation does not allow accurate switching representation at 10 μ s (eg. 40 kHz), an average source approximation of the inverter switching may be used to allow a larger simulation time step².
- H. *Operate at a range of simulation time steps.* The model should not be restricted to operating at a single time step, but should be able to operate within a range (eg. 10 μ s – 20 μ s)
- I. *Have the ability to disable protection models.* Many studies result in inadvertent tripping of converter equipment, and the ability to disable protection functions temporarily provides study engineers with valuable system diagnostic information.
- J. *Include documentation and a sample implementation test case.* Test case models should be configured according to the site-specific real equipment configuration up to the Point of Interconnection. This would include (for example): aggregated generator model, aggregated generator transformer, equivalent collector branch, main step up transformers, gen tie line, and any other static or dynamic reactive resources. Test case should use a single machine infinite bus representation of the system, configured with an appropriate representative SCR, such as 2.5. Access to technical support engineers is desirable.
- K. *Have an identification mechanism for configuration.* The model documentation should provide a clear way to identify the specific settings and equipment configuration which will be used in any

³ Care should be taken to ensure that any user-settable options are not changed in a way that is not implementable in the real hardware, and that any selectable options are actually available at the specific site being considered. Discussion is recommended with the manufacturer prior to any changes being made in model configuration.

- study, such that during commissioning the settings used in the studies can be checked. This may be control revision codes, settings files, or a combination of these and other identification measures.
- L. *Accept external reference variables.* This includes real and reactive power ordered values for Q control modes, or voltage reference values for voltage control modes. Model should accept these reference variables for initialization, and be capable of changing these reference variables mid-simulation, ie. dynamic signal references.
 - M. *Be capable of initializing itself.* Once provided with initial condition variables, the model must initialize and ramp to the ordered output without external input from simulation engineers. Any slower control functions which are included (such as switched shunt controllers or power plant controllers) should also accept initial condition variables if required.
 - N. *Have the ability to scale plant capacity.* The active power capacity of the model should be scalable in some way, either internally or through an external scaling transformer⁴. This is distinct from a dispatchable power order, and is used for modeling different capacities of plant or breaking a lumped equivalent plant into smaller composite models.
 - O. *Have the ability to dispatch its output to values less than nameplate.* This is distinct from scaling a plant from one unit to more than one, and is used for testing plant behaviour at various operating points.
 - P. *Initialize quickly.* Model must reach its ordered initial conditions as quickly as possible (for example <5 seconds) to user supplied terminal conditions.

Study Efficiency Features

In addition, the following elements are required to improve study efficiency, model compatibility, and enable other studies which include the model to be run as efficiently as possible. If these features are not supported, additional discussion is required⁵:

- Q. Model should be compatible with Intel Fortran compiler version 12 and higher.
- R. Model should be compatible with PSCAD version 4.5.3 and higher.
- S. Model supports multiple instances of its own definition in the same simulation case.
- T. Model supports the PSCAD “timed snapshot” feature accessible through project settings.
- U. Model supports the PSCAD “multiple run” feature.
- V. Model does not use or rely upon global variables in the PSCAD environment.
- W. Model should not utilize multiple layers in the PSCAD environment, including ‘disabled’ layers.

⁴ A free publicly available scaling transformer suitable for this purpose is available in the E-Tran library.

⁵ Electrenix has parallelization tools available (E-Tran Plus for PSCAD) which can circumvent compatibility concerns in some cases.

Attachment #1: PSCAD Model Test Checklist

Electranix makes no representations or warranties of any kind concerning this document, whether express, implied, statutory, or other. This includes, without limitation, warranties of title, merchantability, fitness for a particular purpose, non-infringement, absence of latent or other defects, accuracy, or the presence or absence of errors, whether or not known or discoverable. Electranix will not be held liable for any direct, special, indirect, incidental, consequential, punitive, exemplary, or other losses, costs, expenses, or damages arising out of use of this document or any material herein, even if Electranix has been advised of the possibility of such losses, costs, expenses, or damages.

Copyright PSCAD Model Requirements Supplier Checklist © 2020 by Electranix Corporation. Please contact info@electranix.com for information regarding use or modification of this document.

Purpose

This document is a test checklist meant to accompany “PSCAD Model Requirements Rev. 9” provided above and “Attachment #2: PSCAD Model Requirements Supplier Checklist”. The procedures provided in this document are intended to provide an indication of the core model accuracy, performance, and usability features specified in the model requirements. These procedures cannot ultimately prove that the model is compliant with all requirements, as black box models usually hide the details of the equipment controls and protection. It is recommended that the equipment manufacturer supply additional confirmation that the model meets each individual requirement. The requirements in this document do not necessarily represent interconnection criteria for specific individual systems, and may be supplemented or adjusted based on interconnection region.

The tests outlined here are considered “basic”, and may be supplemented by more rigorous testing, including various fault types, depths, and durations, as well as more extensive protection testing and benchmarking against phasor models. This document is not intended to be a guide for thorough benchmarking between PSCAD, PSS/E, and actual equipment, and is subject to revision as the state of the art in EMT modeling evolves.

<i>Model test Summary</i>	
Model Test date:	
Project Name:	
Manufacturer:	
Equipment type: (eg. PV or Wind)	
Equipment version:	
Documentation file:	
Model Files supplied:	

Verification Procedure and Checklist

		Pass/Fail	Comments
<i>Vendor and site specific model verification</i>			
1a	The Vendor's name and the specific version of the model should be clearly observable in the .psc model file.		
1b	Documentation and supporting model filenames should not conflict with model version shown in the .psc model file.		
1c	Model is supplied with a test circuit which is configured for the site specific application. ⁶		
<i>"Real Code" model verification</i>			
2a	Controls are black-boxed, and no PSCAD master library control blocks are visible within control circuits. ⁷ If the model is not based on "real code", a separate validation report is required showing model comparison against hardware tests. ⁸		
<i>Model usability verification</i>			
3a	Model uses a timestep greater than 10 μs ⁹		
3b	Model allows a variation in simulation timestep		
3c	Model compiles using Intel FORTRAN version 12		
3d	Model initializes in 5 seconds or less with a POI level SCR of 2.5. Real power, reactive power, and RMS voltage should reach steady state by this time.		
3e	Model allows multiple instances of itself to be run together in the same case ¹⁰		
<i>Model electrical configuration verification</i>			
4a	Plant level electrical single line diagram (SLD) is included.		

⁶ The test circuit should model all relevant electrical components of the plant and contain a system equivalent. Parameters will be assumed to be site-specific, unless there are obvious indications otherwise, such as an incorrect grid base frequency.

⁷ Black-boxing of controls to a high level does not guarantee that real-code is embedded into the model, however the visibility of PSCAD master-library control blocks in the inner control loops (PLL, inner current controllers, etc.) suggest that the model is generic in nature. Model documentation may contain information on use of real-code in the model.

⁸ All aspects of the controller operation are required to be validated by utilizing a "hardware in loop" platform or other hardware test systems. Model should not be validated against other software models. Validations should include control responses to various types of faults, changes in power and voltage references, changes in system frequency, testing frequency response in sub and super-synchronous ranges, and testing of protection operation. Tests should also be performed under a variety of system strengths, including very weak systems. Other tests may also be required. The validation report is required along with any model updates that result from the more rigorous validation tests.

⁹ Models with timesteps less than 10 μs may be acceptable in situations where a small timestep does not significantly increase the runtime of the total simulation

¹⁰ Depending on specific application and whether E-Tran Plus for PSCAD is allowed to be used to overcome the limitation, this requirement may be waived.

4b	Generator step-up transformer(s) included, with impedance between 5 and 10% on generator base, and matches SLD. ¹¹		
4c	Lumped collector equivalent(s) included, with total charging equal to between 0.5 and 5% of plant rating, and matches SLD. ¹¹		
4d	Substation transformer(s) included, rated appropriately for plant size, and impedance between 6 and 12% on transformer base, and matches SLD. ¹¹		
4e	Model can be scaled to represent any number inverters/turbines, either using a scaling transformer or internal scaling.		
4f	All external devices included in the plant (such as STATCOMs) include appropriate models.		
<i>Plant controller verification</i>			
5a	Model includes power plant controller (PPC)		
5b	PPC accepts an external active power setpoint.		
5c	PPC accepts a voltage setpoint.		
5d	PPC has a mechanism to implement a settable voltage droop.		
5e	Overall plant responds to frequency changes by increasing or decreasing its active power as appropriate. This may be accomplished either at an inverter level or via the PPC. ¹²		
5f	Model initializes to the setpoints specified in the PPC. If droops or deadbands are utilized, the initial values may differ from the setpoints. ¹³		
5g	If external voltage control devices (STATCOM/DVAR, SVC, MSCs) are included in the plant, ensure that the voltage control of these devices is coordinated with the PPC, with no potential for VAR looping or oscillations.		
<i>Basic performance verification¹⁴</i>			
6a	Instantaneous voltage and current waveforms have minimal distortion, and no oscillations are observed.		

¹¹ Impedance range is for sanity checking only. Impedances outside this range may be allowed.

¹² Non-compliance with this item may not require model revision as frequency response may not be required in PSCAD models by some utilities. In this case, a description of the under/over frequency response capabilities of the actual equipment should be provided by the manufacturer.

¹³ If voltage control with droop is implemented, it is preferred that the PPC model requests an initial Q value to match the voltage setpoint. If no initial Q is requested, the voltage setpoint can be biased by the initial Q before it is sent to the PPC. If a non-zero deadband is included in the voltage controller, the deadband can also be considered in the voltage setpoint sent to the PPC.

¹⁴ Performance testing is recommended with a POI level SCR of 2.5 as this is a representative system condition seen during weak system studies. Testing may be performed at higher SCRs if the stable operating SCR of a model is known to be above 2.5.

**PSCAD Model Requirements Rev. 9
May 8, 2020**



6b	Model is able to ride-through and recover from a temporary (no line outage or drop in SCR), 6-cycle, zero-impedance, three-phase fault at the high side of the station transformer, with a POI level SCR of 2.5.		
6c	Model responds to a step change in PPC voltage setpoint, reaching 90% of the new value between 1 and 10 seconds in a test system with POI level SCR of 2.5. (Various systems may have specific speed requirements, which should be met)		
6d	Model responds to a step change in PPC active power setpoint, reaching 90% of the new value between 1 and 10 seconds in a test system with POI level SCR of 2.5. ¹⁵		
<i>Basic protection verification</i> ¹⁶			
7a	Protection settings are implemented. These could be available as inputs in the model, or hard-coded in the black-boxed controls. ¹⁷		
7b	Option to disable protection models is present. ¹⁸		
7c	Model trips or blocks when terminal voltage rises above 1.3 pu for 1.5 second. ¹⁹		
7d	Model trips or blocks when terminal voltage falls below 0.2 pu for 1.5 second. ¹⁹		
7e	Model clearly displays trip / diagnostic signals indicating the status of all pertinent protection elements		
<i>Documentation</i>			
8a	Model documentation states compliance with "PSCAD Model Requirements Rev. 9 Rev. 9" ²⁰ , or is supplied with a completed PSCAD Model Requirements Supplier Checklist.		
8b	Model documentation includes instructions for setup and running of the model, including the recommended range of simulation timesteps. Documentation should give a clear description of trip / operation code signals produced by model.		

¹⁵ Different response time criteria may apply depending on specific interconnection region.

¹⁶ There are many protection functions which should be modelled, per footnote 1, and these basic tests will not be proof that these are modelled.

¹⁷ If settings are not visible in model or documentation, verification that protection settings are implemented in the PSCAD model should be received from the manufacturer.

¹⁸ Non-compliance may not require model revision as many studies do not require testing with protection settings disabled.

¹⁹ Non-compliance with this item should result in verification of protection settings implementation from the manufacturer, as some models may have capabilities beyond what is listed here.

²⁰ Non-compliance may be waived in systems which do not require compliance with the model requirements document.

Attachment #2: PSCAD Model Requirements Supplier Checklist

Electranix makes no representations or warranties of any kind concerning this document, whether express, implied, statutory, or other. This includes, without limitation, warranties of title, merchantability, fitness for a particular purpose, non-infringement, absence of latent or other defects, accuracy, or the presence or absence of errors, whether or not known or discoverable. Electranix will not be held liable for any direct, special, indirect, incidental, consequential, punitive, exemplary, or other losses, costs, expenses, or damages arising out of use of this document or any material herein, even if Electranix has been advised of the possibility of such losses, costs, expenses, or damages.

Copyright PSCAD Model Requirements Supplier Checklist © 2020 by Electranix Corporation. Please contact info@electranix.com for information regarding use or modification of this document.

Purpose

This document is a model requirements checklist which should be completed by the supplier of the model and submitted alongside each PSCAD model. This document accompanies the “PSCAD Model Requirements Rev. 9” document above (PMR), which should be used for further reference to describe the requirements associated with each point. Generic testing of the model may be done using “Attachment #1: PSCAD Model Test Checklist”, which may be used as a reference.

Model supplier must review every item in the checklist and indicate compliance for each item. If the supplied model does not meet any of the requirements an explanation of the deficiency should be provided in the comments column.

<i>Model Submission Summary (to be completed by model supplier)</i>	
Submission date:	
Project Name:	
Primary contact information for model related questions:	
Secondary contact information for model related questions:	
Manufacturer:	
Equipment type: (eg. PV or Wind)	
Equipment version:	
Documentation file(s):	
Model Files supplied:	

Model Requirements Checklist				Model Complies? (Yes/No)	Comments
1	<i>Model Accuracy Features</i>				
1.1	Power electronic controls are modelled by interfacing with actual firmware code from the inverter (“real code” model), or includes detailed validation report.	A, B			
1.2	Operating modes which require system specific adjustment are accessible.	B			
1.3	Plant level controller is included. ²¹	B			
1.4	Model is capable of controlling frequency ²²	B			
1.5	Includes pertinent electrical and mechanical features, such as gearboxes, pitch controllers, or other features which impact the plant performance in the simulation period. ²³	C			
1.6	All protections which could impact ride-through performance are modelled in detail.	D			
1.7	Model is configured for the specific site being evaluated, as far as they are known.	E			
2	<i>Model and Project Documentation</i>				
2.1	Model includes documentation.	J			
2.2	Documentation includes instruction for setup and running the model.	J			

²¹ If the plant is part of a multi-plant control scheme, a description of the overall scheme should be provided, and corresponding PPC models should be configured to control multiple plants accordingly.

²² Frequency control model requirements may vary by region. Example response time may be less than 10 seconds.

²³ Simulation period may vary depending on the model use, but 10 seconds of simulation following an event such as a fault is a typical period.

This work is licensed under the Creative Commons Attribution 4.0 International License. To view a copy of this license, visit <http://creativecommons.org/licenses/by/4.0/> or send a letter to Creative Commons, PO Box 1866, Mountain View, CA 94042, USA.

**Recommended PSCAD Model Requirements Rev. 9
May 8, 2020**



2.3	Model is supplied with a sample test case including site specific plant representation.	J	
2.4	Plant single line diagram is provided, and aligns with model	J	
2.5	Model documentation provides a clear way to identify site-specific settings and equipment configuration.	K	
3	<i>Model Usability Features</i>		
3.01	Control or hardware options are accessible to the user as applicable.	F	
3.02	Diagnostic flags are visible to the user.	F	
3.03	Model uses a timestep greater than 10 μs.	G	
3.04	Model allows a range of simulation timesteps (ie. not restricted to a single timestep).	H	
3.05	Protection model may be disabled for troubleshooting	I	
3.06	Model accepts external reference variables for active and reactive power and voltage setpoint, and these may be changed dynamically during the simulation.	L	
3.07	Model is capable of initializing itself.	M	
3.08	Active power capacity is scalable.	N	
3.09	Active power is dispatchable.	O	
3.10	Model reaches setpoint P, Q, and V in 5 seconds or less	P	
3.11	Model compatible with Intel FORTRAN version 12 and higher.	Q	
3.12	Model compiles using PSCAD version 4.5.3 or higher.	R	
3.13	Model supports multiple instances of its own definition in a single PSCAD case.	S	
3.14	Model supports PSCAD “snapshot” feature.	T	

This work is licensed under the Creative Commons Attribution 4.0 International License. To view a copy of this license, visit <http://creativecommons.org/licenses/by/4.0/> or send a letter to Creative Commons, PO Box 1866, Mountain View, CA 94042, USA.

**Recommended PSCAD Model Requirements Rev. 9
 May 8, 2020**



3.15	Model supports the PSCAD “multiple run” feature.	U	
3.16	Model does not use PSCAD global variables.	V	
3.17	Model does not use PSCAD layer functionality	W	

This work is licensed under the Creative Commons Attribution 4.0 International License. To view a copy of this license, visit <http://creativecommons.org/licenses/by/4.0/> or send a letter to Creative Commons, PO Box 1866, Mountain View, CA 94042, USA.

DETAILED INSTRUCTIONS FOR COMMUNITY OUTREACH PLAN

- The Community Outreach Plan should be as current and explanatory as possible.
 - The Community Outreach Plan information must be included in the information Proposers selected to the Final Award Group make available on their website when the website is posted publicly.
- Proposers selected to the Final Award Group must develop a public Project website, which shall include all the information on the Community Outreach Plan table for their Project.
- Proposers must develop Project presentations that include all the information on the Community Outreach Plan table (sample template provided).
- Due to the uncertainty of the duration of the COVID-19 pandemic, all Proposers are required to plan for both in-person and virtual community meetings. As we near the dates that community meetings are scheduled, in the interest of public health and safety, the conditions at the time will determine if in-person meetings or virtual meetings will be required.
 - Virtual community meetings can either be community televised, or online, but must incorporate technology that allows for live engagement and interaction between the Proposer and community participants.
- Proposers must communicate important information about the Project with stakeholders in advance of community meetings.
- Proposers must perform media outreach (earned media) and advertising (paid media) to raise community awareness of any public meeting. Media advisories (sample attached) must be issued to the following media and organizations a minimum of 30 days prior to a public meeting. Media advisories do not need to be reviewed and approved by Hawaiian Electric, but must be shared with Hawaiian Electric for awareness.
 - For Oahu Projects
 - Star Advertiser
 - Civil Beat
 - Hawaii News Now
 - KHON2 News
 - KITV4 News
 - Neighborhood Boards
 - For Maui Projects
 - Maui News
 - Maui Now
 - Civil Beat
 - Hawaii News Now
 - KHON2 News
 - KITV4 News
 - For Hawaii Island Projects
 - Hawaii Tribune Herald
 - West Hawaii Today
 - Civil Beat
 - Hawaii News Now
 - KHON2 News
 - KITV4 News
- Advertisements must be placed in area community publications.
 - Guidance from the Company can be provided upon request
 - Information in the ads must be consistent with the media advisory
- Public comments in support and in opposition to the proposed Project must be compiled and filed verbatim with the Public Utilities Commission.
- Proposers must work with and inform neighboring communities and stakeholders to provide community members timely information during ALL phases of the project, which must include,

Appendix B Attachment 4

but not be limited to the Power Purchase Agreement negotiation period, the permitting process periods, and throughout construction.

- Should any COVID-19 related events interfere with the Proposer's ability to perform the listed actions, Proposer should inform the Company immediately of such effects for Company's consideration and guidance, and possible proposal of alternate actions.

CONTACT: **NAME, 808.XXX.XXXX** **FOR IMMEDIATE RELEASE**
Email address Date

Media Advisory: Title

Project description to be drafted by developer. Description must include the location of proposed project and supporting background information.

Date: TBD

Time: TBD

Location: TBD

Purpose: To share information about a **TYPE (e. g. CBRE solar, etc.)** renewable energy project proposed to be developed in **COMMUNITY** near **AREA REFERENCE** and to solicit public comments to be filed with the Public Utilities Commission.

Contact: For more information, call **808.XXX.XXXX** or visit **(website/social media)**

###

Appendix B Attachment 5

Project Name
Proposer Name

Project Benefits

- Details

Community Benefits

- Details

Proposed Facility Location in/near what City/Area

- Map
- Dimensions of proposed project
- Include all project components

Project Description

- Details

Site Layout Plan

- Project Layout
- Project Visual Simulations
 - Multiple public vantage points

Appendix B Attachment 5

Interconnection Route

- Map

Required Government Permits and Approvals

- Preliminary Schedule
- Opportunities for public comment

Environmental Impacts

- Preliminary environmental assessment of the site (including any pre-existing environmental conditions)

Cultural Impacts

- Identify any cultural, historic or natural resources that will be impacted by the project
- Describe the potential impacts on these resources
- Identify measures to mitigate such impacts.

Where to Find More Information

- Project website
- Proposer email and contact information

Appendix B Attachment 5

How to Provide Comments

DRAFT

REQUEST FOR PROPOSALS

FOR

VARIABLE RENEWABLE DISPATCHABLE GENERATION

PAIRED WITH ENERGY STORAGE

AND

COMMUNITY-BASED RENEWABLE ENERGY

ISLAND OF LĀNA‘I

SEPTEMBER 8, 2020

Docket No. 2015-0389

*Appendix C – Code of Conduct Procedures
Manual*



**Maui
Electric**

I. INTRODUCTION

The Framework for Competitive Bidding ("Framework") adopted on December 8, 2006, by the Public Utilities Commission of the State of Hawaii (the "Commission") pursuant to Decision and Order No. 23121 (Docket No. 03-0372, Instituting a Proceeding to Investigate Competitive Bidding for New Generating Capacity in Hawaii) requires that the utility develop and follow a Code of Conduct whenever a utility or its affiliate seeks to advance an energy generation resource proposal in response to a request for proposals ("RFP") issued by the Company. Section III.A.4 of the Framework required the utility to submit to the Commission for review and approval (subject to modification if necessary) a code of conduct prior to the commencement of any competitive bid process under the Framework. The proposed *Code of Conduct Pertaining to the Implementation of a Competitive Bidding Process for Community-Based Renewable Energy* (the "Code of Conduct") requires the Companies to also propose this *Code of Conduct Procedures Manual* (the "Procedures Manual") to implement the requirements of the Framework and the Code of Conduct.

This Procedures Manual has been developed to outline the procedures to be followed and the policies that have been developed surrounding the implementation of the Companies' competitive bidding process for system resources. This Code of Conduct Procedures Manual has been developed for the Companies' Community-Based Renewable Energy RFPs and in accordance with the requirements of Section IV.H.9.a(iii) of the Framework and outlines requirements (1), (3) and (4) of such section, namely: (1) the protocols for communicating with Proposers, the Company Self-Build team, and others; (3) the documentation forms, including logs for any communications with proposers; and (4) other information consistent with the requirements of the solicitation process. Requirement (2) of the section, the evaluation process in detail and the methodologies for undertaking the evaluation process for the RFP are described in detail in the Community-Based Renewable Energy RFP. The bid evaluation process and methodology will consider both price/system impacts and non-price criteria in accordance with Section IV.E of the Framework and Tariff Rule 19.

The procedures and policies set forth herein have been designed to ensure that the procurement process is undertaken in a fair and equitable manner and that each Proposer is afforded an equal opportunity to participate and compete within the RFP requirements.

This Procedures Manual is intended to be followed by Company personnel in connection with implementing the Companies' solicitation process and to manage communications between Company personnel and consultants participating in the RFP processes covered by the Framework. Necessary additions, deletions, and/or changes depending on the circumstances surrounding the RFP and directions from the IO may be required.

II. DEFINITIONS

- Affiliate – Any person or entity that possesses an “affiliated interest” in a utility as defined by section 269-19.5, Hawaii Revised Statutes (“HRS”), including a utility’s parent holding company but excluding a utility’s subsidiary or parent which is also a regulated utility.
- Affiliate Team – Employees and consultants of an Affiliate of the Company who prepare a proposal to be submitted to the Company in response to a Company RFP.
- ATRs – The Affiliate Transaction Requirements, issued by the Commission, applicable to the Companies and Affiliates, attached as Exhibit B to Order No. 36112 issued on January 24, 2019 in Docket No. 2018-0065.
- Code of Conduct – The *Code of Conduct Pertaining to the Implementation of a Competitive Bidding Process for Community-Based Renewable Energy* developed by Hawaiian Electric Company, Inc., Maui Electric Company, Limited and Hawaii Electric Light Company, Inc. (each, a “Company” and collectively, the “Companies”) to ensure the fairness and integrity of the competitive bidding process, in particular where the host utility or its affiliate seeks to advance its own system resource proposal in response to an RFP. The Code of Conduct follows the requirements described in Section IV.H.9.c of the Framework.

- Code of Conduct Acknowledgement – The Competitive Bidding Code of Conduct Acknowledgement of Receipt form acknowledging review of, and agreeing to abide by, the Code of Conduct and this Procedures Manual.
- Communications Log – A written record to note activities and/or information shared between the Company RFP Team or Company Self-Build Team with Shared Resources or Unassigned Company Resources, accessed via the RFP Communication Tool Kit SharePoint Site.
- Companies' Executive in Charge – The Companies' executive responsible for ensuring compliance with this Code of Conduct and serving as the point of contact for the Independent Observer for reporting any violations by the Companies' of the Code of Conduct. The Companies' Corporate Compliance Officer shall remain responsible for the Companies' independent corporate code of conduct and may support compliance matters and questions arising with employees, agents and other representatives of the Companies, e.g., conflicts of interest, with respect to this Code of Conduct.
- Company RFP Team – The Company personnel and outside consultants responsible for the development of the Company's RFPs conducted under the Framework and the evaluation of bids submitted in response to these RFPs. Subject to the transfer rules specified herein, the Company RFP Team will have fixed team members who will not have any involvement with the Company Self-Build Team for the subject RFP.
- Company Self-Build Team – The Company personnel and outside consultants responsible for the development of the Company's self-build responses to the RFP. Subject to the transfer rules specified herein, the Company Self-Build Team will have fixed team members who will not have any involvement with the Company RFP Team for the subject RFP.
- Confidential Information – Any non-public information developed and provided by the Company (i.e., proprietary system information, etc.) or Proposers during the RFP process (such non-public information may include, for example, the identity of competing Proposers, and their technical, trade or financial information). This term includes any material non-public information regarding the RFP process developed for and used during the competitive bidding solicitation process, such as the evaluation process or criteria. Confidential Information does not include

public information, such as information in the Company's public filings with the Commission.

- Director of Renewable Acquisition – The supervisor of the Division that will oversee the Company's competitive bidding process.
- Eligible Proposer – A Proposer who has met the minimum requirements and threshold requirements in the RFP necessary to remain eligible to compete in the process.
- Energy Contract Manager – The staff position(s) within the Company's Renewable Acquisition Division responsible for managing the Company RFP Team(s). The Energy Contract Manager shall be a member of the Company RFP Team he/she manages.
- Framework – The Framework for Competitive Bidding contained in Decision & Order No. 23121 issued by Commission on December 8, 2006, to establish rules for competitive bidding in response to a request for proposals when a utility seeks to acquire new generation resources.
- Independent Observer ("IO") – The neutral person or entity appointed by either the Commission or utility to monitor the utility's competitive bidding process, and to advise the utility and Commission on matters arising out of the competitive bidding process, as described in Part III.C of the Framework.
- Manager of Energy Procurement - The supervisor of the department within the Company's Renewable Acquisition Division responsible for directing the resources responsible for the implementation of the competitive bidding process pursuant to the Framework. The Manager of Energy Procurement will report to the Director of Renewable Acquisition on the status of the competitive bidding process and shall be a member of the Company RFP Team.
- Non-Price Evaluation Team – Employees and consultants of the Company who evaluate the Proposal non-price related criteria as set forth in these RFPs. Non-Price Evaluation Team members will not include any Shared Resources and will be solely made up of Company RFP Team Members.
- Non-Wires Alternative - An electricity grid project that uses non-traditional transmission and distribution (T&D) solutions, such as distributed generation (DG), energy storage, energy efficiency (EE), demand response (DR) and grid software and controls, to defer or avoid the need for conventional transmission and/or

distribution infrastructure investments.

- Price Evaluation Team – Employees and consultants of the Company who evaluate the Proposal price related criteria set forth in these RFPs. Price Evaluation Team members will not include any Shared Resources and will be solely made up of Company RFP Team Members.
- Proposer – Entity who submits or plans to submit a proposal in response to a Company-issued RFP. An Affiliate of the Company or a Company Self-Build Team participating in the RFP and submitting a proposal shall be considered a Proposer.
- RFP – A written request for proposals issued by one of the Companies to publicly solicit bids to supply future system resources to the Company pursuant to the competitive bidding process established in the Framework.
- Roster – A consolidated list of members that comprise the Company RFP Team, Company Self-Build Team, Shared Resources and Unassigned Company Resources located in the RFP Communication Tool Kit SharePoint Site. Company employee names and titles and consultants in their designated role will be identified.
- Shared Resource – Company employees and consultants who, because of the scarcity of their expertise within the Company, are designated and authorized to provide information or input to both the Company RFP Team and the Company Self-Build Team (but not any Affiliate Team) and is not a resource dedicated to either team. For example, Shared Resources may include an environmental attorney and members of the Company’s Risk Management Department.
- Unassigned Company Resource – Company employees unassigned to an essential team that may be called upon by the Company RFP Team and/or the Company Self-Build Team (but not any Affiliate Team) to assist in meeting unforeseen tasks for the RFP or the self-build proposal. For example, the Company RFP Team may be unable to evaluate an unforeseen technical specification included in a bid. In that event, the Company RFP team would need to request assistance from a Company employee or a consultant that is not already assigned to an essential team and possesses the specific expertise. Such personnel are intended to assist the requesting team only in an ad hoc manner, limited in scope and purpose to the particular task required.

III. STATEMENT OF OBJECTIVES

On April 9, 2020, the Commission issued Order 37070, commencing Phase 2 of the Community-Based Renewable Energy Program ("Phase 2"). Phase 2 requires the Companies to implement competitive bidding to procure CBRE projects on all islands served by the Companies. These procurements will be concurrent and overlapping. Subsequent phases of CBRE may require further procurements through competitive bidding. Accordingly, under the Framework and the Code of Conduct, for each of the competitive procurements under the program, the Companies will undertake a detailed multi-stage review and evaluation process whereby eligible proposals will be selected based upon their ability to most cost-effectively and reliably satisfy the CBRE program requirements.

Given that multiple RFPs for CBRE, including and in addition to other RFPs currently being administered by the Companies, will be active at the same time, and because the Companies must work expeditiously, in order to consistently ensure the competitive benefits of the procurement process while continuing to provide equitable and fair consideration for all proposals, the Companies will endeavor to create, designate and maintain the Roster at all times for quicker and more decisive implementation across all active RFPs. Subject to the transfer rules specified herein, the Roster will be maintained for the durations of the RFPs. The Companies also intend that the evaluation process will be well-documented so that the results of the evaluation can be fully reviewed by an IO to confirm that all proposals were treated in a fair and consistent manner.

The Code of Conduct and this Procedures Manual address (1) communication requirements and procedures associated with the relationship between utility employees (Company RFP Team, Company Self-Build Team, Shared Resources and Unassigned Company Resources); (2) communication requirements and procedures associated with the relationship between the Company RFP Team, the Company Self-Build Team and Proposers; and (3) communication requirements associated with the relationship between Company management and the Company RFP Team.

The Code of Conduct and this Procedures Manual also include procedures for the sharing of resources, where appropriate, by the Company RFP Team and the Company

Self-Build Team for the purposes of completing their efforts to effectively evaluate an RFP or to submit a bid in response to an RFP. The small size of the Companies and limitation of resources will require specialized services, information exchange and sharing of resources in certain limited circumstances. Company personnel and consultants identified as "Shared Resources" shall be designated by the Companies for this specific purpose.

IV. ORGANIZATION AND COMMUNICATION RESPONSIBILITIES

This section outlines the RFP organizational structure for the development of the RFP and the Company self-build options and the organization's responsibilities to ensure that communications between Company personnel and consultants working on their respective RFPs or self-build projects are conducted in a fair, consistent, and equitable basis so that the Company Self-Build Team does not enjoy any unfair advantage over other Proposers responding to an RFP.

A. Organization

The Companies shall identify and maintain two separate teams to facilitate the independence and objectivity of the Company resources working on an RFP and ensure an arms-length relationship with the resources working on the Company's self-build project to avoid any real or perceived inequity in an RFP process. The two essential teams shall be the "Company RFP Team" and the "Company Self-Build Team."

Other limited Company resources, such as select staff from various functional areas of the Company that are in short supply and thus cannot be dedicated solely to either team, may be designated as "Shared Resources" to perform services for the Company RFP Team and Company Self-Build Team. Shared Resource employees are allowed to carry on with both their RFP (for either the Company RFP Team and/or the Company Self-Build Team) and regular functions throughout the resource planning process (including the development of any Company Parallel or Contingency Plan as defined in the Framework), which may require communications with or services performed for the Company Self-Build Team. Shared Resource employees, however, will not participate in the evaluation and selection process of proposals submitted in response to

an RFP. Rules for communications between Shared Resources and the essential teams are specified below.

Company employees unassigned to an RFP may be called upon by the Company RFP Team, Company Self-Build Team, or both for help to meet unforeseen tasks. After completing the Code of Conduct training, these "Unassigned Company Resources" are eligible to assist on an ad hoc basis with the requirement that all communications as an Unassigned Company Resource must be memorialized and logged in the same manner as communications with Shared Resources on the Communication Log. If an Unassigned Company Resource is called upon repeatedly for a substantial amount of assistance by a particular team, the employee should be assigned to such team or evaluated for designation as a shared resource.

B. Essential Teams

1. Company RFP Team. The Company RFP Team, tasked with preparing the RFP and evaluating the responses and bids in response to the RFP, will consist primarily of Director/Manager-level and other experienced employees together with possible outside consultants, with backgrounds in a number of disciplines necessary to conduct a thorough evaluation of each proposal. The Company RFP Team will be comprised of a Price Evaluation Team and a Non-Price Evaluation Team and will be prepared to evaluate proposals on the basis of their price and non-price aspects pertaining to their level of expertise. Members of the Company RFP Team will include professionals with experience in the following areas of expertise: engineering, siting/land use, environmental, transmission planning, fuel procurement, legal, financial planning, system operations, integrated resource planning, generation planning, production cost analysis, and others as needed.

The Price Evaluation Team and the Non-Price Evaluation Team will conduct their sections of the bid evaluation process separately and will not share the results of their evaluation with members of the other sub-team. Each team will submit their evaluation results to an oversight team, which will be responsible for compiling the results of the evaluations and selecting the Priority List.

The Energy Contract Manager will be responsible for directing the evaluation efforts of the Company RFP Team when the proposals are received. The Energy Contract Manager will be responsible for maintaining the documentation underlying the evaluation of each proposal as well as all communications with Proposers.

2. The Company Self-Build Team. The Company Self-Build Team, tasked with preparing any Company proposal to be submitted by the Company in response to a Company RFP, will consist primarily of Company employees, along with possible outside consultants with backgrounds in a number of disciplines necessary to complete a competitive proposal in response to a Company RFP. The members of the team will include professionals with experience in the following areas of expertise: engineering, siting/land use, environmental, transmission planning, fuel procurement, legal, financial planning, system operations, integrated resource planning, generation planning, production cost analysis, and others as needed.

3. Affiliate Team. Any Affiliate Team will be comprised solely of employees and consultants of the Affiliate and no Company employee or consultant shall serve as a member of an Affiliate Team; provided, however, that a consultant may perform services for an Affiliate and the Company so long as appropriate "walls" are established satisfactory to the Company that ensures that employees of the consultant working for the Affiliate Team do not also perform work for the Company nor communicate with employees of the consultant performing work for the Company, and vice versa. The Company will inform consultants providing services for the Company RFP Team of these separation requirements, and will seek confirmation in writing from any consultant performing services for an Affiliate and the Company that such separation requirements will be met. Affiliate Teams will be considered and treated as separate independent third-party Proposers for all purposes within any RFP and shall have no access to, interaction or communications with Shared Resources or Unassigned Company Resources for the purpose of completing a proposal in response to any RFP. Affiliate Teams shall also be subject at all times to the terms, conditions and restrictions specified in the Company's ATRs.

4. Transfers between Teams. As members of both the Company RFP

Team and the Company Self-Build Team are intended to be fixed, transfers between teams should not be permitted. However, there will be instances where a member of a particular team (whether Company RFP or Company Self-Build) transfers to a position in which he/she may be requested, as part of his/her new job responsibilities, to participate as a member of the other team. Such employee shall not be permitted to transfer from one team to the other during the pendency of any particular RFP (or stage or phase of a particular RFP). After completion of the RFP (or stage or phase of a particular RFP) under which the employee recently participated, the employee may transfer to the other team under the following conditions: (a) the employee is prohibited from disclosing any Confidential Information known to such employee as a result of being a member of his/her former team with members of the new team he/she is joining; and (b) for a period of one (1) year, such employee shall not participate or be involved in the evaluation of any subsequent stage(s) or phase(s) of a prior RFP which such employee participated in with his/her former team.

Transfers of employees between the Company and any Affiliate and their subsequent work on RFPs shall be subject to the terms, conditions and restrictions specified in the ATRs.

C. Communications Protocols

1. Overview and General Requirements.

The Company has developed policies and procedures governing communication between the Company RFP Team, the Company Self-Build Team, Shared Resources, the Proposers, the IO, and with the Commission regarding RFP design and bid evaluation. Bid information and evaluation data and information shall not be communicated between members of the Company RFP Team, outside parties and other employees within the Companies except to those with a business need to know.

To ensure that the competitive bidding process is fair and unbiased, that all Proposers have access to the same information so that no Proposer has an unfair advantage, and that any Company self-build and/or Affiliate proposals do not have any unfair competitive advantage over third-party bids, the Companies shall follow the Code

of Conduct whenever the utility or its Affiliate is seeking to advance a resource proposal as provided in Section IV.H.9.b of the Framework.

Each employee or consultant on the Company RFP Team, Company Self-Build Team and Shared Resources shall read, acknowledge and sign the Code of Conduct Acknowledgement. Unassigned Company Resources who are called upon by the Company RFP Team or Company Self-Build Team for help to meet unforeseen tasks shall also read, acknowledge and sign the Code of Conduct Acknowledgement.

The Company issuing the RFP will establish a shared drive on its corporate computer network designed to maintain the bid evaluation documentation and other information associated with the bidding process. Only Company RFP Team members will have access to all the files on the shared drive.

In cases where staffing and resources are limited or constrained, the Company may identify Shared Resources or those employees eligible to provide information or serve as a resource to both the Company RFP Team and the Company Self-Build Team. Specific rules to log communications with the Company RFP Team or the Company Self-Build Team are described below.

Shared Resources will not have access to the Company's shared drive established for the RFP process which will include the documentation of the bid evaluation results.

Team members should clearly mark all e-mails, documents, or other communications that contain Confidential Information and make clear which team should not receive it with the following header or a substantially similar message: "This communication contains self-build information that must be kept confidential. DO NOT copy, forward, or discuss the contents with Company RFP Team members" OR "This communication contains Company RFP Team information that must be kept confidential. DO NOT copy, forward, or discuss the contents with Company Self-Build Team members."

2. Communications Between the Company RFP Team and

Proposers, including the Company Self-Build Team and any Affiliate Team.

During the RFP process, the Energy Contract Manager shall serve as the primary contact person for all RFP communications with Proposers. This is important from the standpoint of maintaining consistency and confidentiality of information between Proposers and the Company. For documentation and oversight purposes, all communications from Proposers must be submitted to an established website link provided by the Company (the "Company RFP website"). The IO will monitor all communications through the Company RFP website. To ensure fair and equal access to information, any Company Self-Build Team and/or Affiliate Team shall be considered a Proposer for communication purposes and any request for information from the Company Self-Build Team or Affiliate Team to the Company RFP Team shall be through the Company RFP website.

Subject to confidentiality obligations, it is the objective of the Code of Conduct that all Proposers, including the Company Self-Build Team and any Affiliate Team, receive access to information released by the Company RFP Team, whether in response to a question from a Proposer or not, at the same time.

The communications process for addressing questions and requests for information from Proposers, and for the Company RFP Team to provide information to Proposers, is provided below:

- a. Other than during Company sponsored conferences, Proposers must submit all questions to the Company RFP website or the designated RFP email address (if the Company RFP website has not been opened yet for the RFP).
- b. Questions will be reviewed and responses will be coordinated with the appropriate functional area within the Company for a response. Every reasonable effort will be made to provide responses in a timely manner.

- c. All responses, including the classification of such response, i.e., whether non-confidential or confidential as described below, will be provided to the IO for monitoring purposes via email or the PowerAdvocate messaging system. The IO may choose to comment on any response at its discretion.

- d. Depending on the questions received, responses may involve Confidential Information of the Company and/or Proposers. Release of any Company Confidential Information must be approved in advance by the Company executive authorized to release the Confidential Information. Any release of Company Confidential Information shall be accompanied by appropriate confidentiality and non-disclosure agreements, protective orders or other means required to maintain the confidentiality of the Company Confidential Information while still permitting its disclosure under circumstances deemed appropriate by the responsible Company executive. Other non-Company Confidential Information will not be shared without the prior written consent of the owner of such Confidential Information and the execution of appropriate confidentiality and non-disclosure agreements by all recipients of such Confidential Information. Responses will be categorized as follows:
 - i. Non-Confidential Responses: Questions and responses will either be posted directly on the Company RFP website (process-related questions or simple, non-substantive information) or a description of the information that can be made available will be posted and Proposers will be instructed to submit a request to the Company via the Company RFP website to receive a copy.

 - ii. Confidential Responses: Questions and a description or notice of a Confidential Information response will be posted on

the Company RFP website and Proposers will be instructed to submit a request to the Company via the Company RFP website to receive instructions on how to access the Confidential Information. The Confidential Information will only be provided to the requestor after receipt of an executed confidentiality and non-disclosure agreement. Only those who have qualified to submit a bid (i.e., Eligible Proposers) and have executed a confidentiality and non-disclosure agreement will be considered for receipt of Confidential Information.

iii. Process for Distribution of Confidential Information: Confidential Information provided in response to questions from proposers may be made available only to parties as indicated above via the following:

A. Confidential Information that is approved for exchanging on a secured access site: (1) Confidential Information may be made available on a secured website with an individual password provided to each approved Proposer; and (2) Confidential Information in documents may be transmitted to approved recipients through the Company's secure email system.

B. Confidential Information that can be made available for inspection only, but cannot be copied: There may be some types of Confidential Information that the Company may consider making available for inspection only with no copies allowed. This type of Confidential Information will be made available on Company premises for inspection only. Proposers will be advised via the Company RFP website to make arrangements with Company staff to view the Confidential Information.

C. Confidential Information that may not be released:

In the event that Proposers submit questions that require responses that the Company feels are not appropriate to provide for reasons which may include, but not be limited to, safety, security, protection of trade secrets or intellectual property rights, Proposers will be advised as such via the Company RFP website.

- e. Prior to and during the RFP, and outside of the Company RFP website protocol, developers may direct questions to the Company prior to submitting a Proposal to discuss specific questions regarding their specific Proposal. Questions shall be directed to the Company Contact for Proposals listed in the particular applicable RFP. Questions and responses that do not contain Confidential Information and which are deemed relevant to all Proposers will be published without identifying information via the Company RFP website.
- f. Once bids are received, the Company may submit information requests to Proposers to clarify their proposals or request additional information. All contacts with Proposers will be through the Company RFP website. All contacts and information exchanged will be under the oversight of the IO.
- g. A single exception to the communication process outlined above shall be instituted for the purpose of facilitating the verification of proposed project models and documentation required to perform the IRS. For this limited scope, the Company's Manager of Interconnection Services will serve as the primary contact person for all such interconnection communications with the Proposers on the Priority List, provided that all necessary confidentiality and

non-disclosure agreements are in place. The Manager of Interconnection Services and personnel in the Interconnection Services Department shall be members of the Company RFP Team. Interconnection communications will be limited to a Proposer's bid and no more information other than as necessary to facilitate such communications will be permitted. Discussion of locations of proposed projects shall be limited to that necessary only to determine the interconnection requirements of such project. The IO shall have the right to monitor all such communications in his/her discretion.

3. Communications Between the Companies and the Commission.

The Company's Regulatory Affairs staff will be responsible for initiating communication with the Commission regarding the RFP or the Companies' evaluation process. Regular updates may be provided to the Commission regarding the RFP process if requested.

4. Communications Between the Company RFP Team and the IO.

Communications between the Company RFP Team and the IO will be required for many aspects of the evaluation process. The IO is also required to maintain confidentiality of any Confidential Information. The IO will coordinate all activities through the Energy Contract Manager. The IO will be invited to participate in any meetings or discussions between the Company RFP Team and the Proposers and other communications as noted above. Sufficient notice will be provided whenever possible and teleconference and/or web conference alternatives may be utilized.

5. Communications Between the Company RFP Team and the Company Self-Build Team or any Affiliate Team.

Any communication between the Company RFP Team and the Company Self-Build Team or any Affiliate Team with respect to the RFP shall be handled no differently than with Proposers and other outside parties. Accordingly, the Company Self-Build Team or any Affiliate Team will be required to submit any questions or information requests to the Company RFP Team via the Company RFP website and all responses will be provided in the same manner as to other Proposers. Accordingly, as stated in Section 2 above, responses will be provided to the IO for monitoring purposes via email or the PowerAdvocate messaging system. Members of the Company RFP Team are prohibited from providing any input into the development of the self-build option by the Company or an Affiliate. Company RFP Team members are prohibited from sharing any Confidential Information (i.e., detailed evaluation criteria, other proposals, etc.) with any Company Self-Build or Affiliate Teams except in accordance with the procedures in the Code of Conduct, this Manual or the RFP.

Company RFP Team members and Company Self-Build Team members may continue to work with each other on projects not related to the RFP. Further, members of each respective team do not have to be physically separated from each other, but members of each team must make reasonable efforts to keep all Confidential Information (including electronic data) secure and inaccessible to the other team.

Company RFP Team members and Affiliate Team members may continue to work with each other on matters not related to the RFP as permitted under the ATRs.

6. Communications among the Company RFP Team, the Company Self-Build Team and Shared Resources.

Shared Resources may provide services to the Company RFP Team and the Company Self-Build Team (but not any Affiliate Team). Shared Resources shall be limited as much as possible to instances where Company resources cannot provide a dedicated member to the Company RFP Team and the Company Self-Build Team at the same time and still provide the necessary functions of its area to the Company as a whole. Shared

Resources are expressly prohibited from providing any information developed on behalf of the Company RFP Team to the Company Self-Build Team or any information developed on behalf of the Company Self-Build Team with the Company RFP Team, except through the formal communication process outlined above, i.e., through the Company RFP website.

Additionally, a written record of the time, date and substance of all conversations, data and written material directly or indirectly exchanged with the Company RFP Team or the Company Self-Build Team that pertain to the RFP shall be maintained on the Communications Log. The RFP Communication Tool Kit SharePoint Site will be set up and managed by the Energy Contract Manager to provide an easy to use and understand mechanism to log and memorialize these conversations.

Shared Resources will not have direct access to the Company's shared drive developed for the RFP process which will include documentation of the bid evaluation results.

7. Communications between the Company RFP Team, the Company Self-Build Team and any Unassigned Company Resource or consultant that is not a Shared Resource.

There may be times where a Company RFP or Company Self-Build team (but not an Affiliate Team) member may need ancillary or other ministerial or administrative assistance that requires communication and/or assistance from Company personnel who are neither on any team nor considered a Shared Resource. Under those circumstances, such personnel may assist the requesting team member on an ad hoc basis upon the following conditions:

- a. The essential team member making the request must inform the Company personnel that sharing of the requested information or assistance with the other team, be it the Company RFP or Company Self-Build Team, is expressly prohibited under the Code of Conduct.

b. The assisting Company personnel shall complete the Code of Conduct training and sign the Code of Conduct Acknowledgement.

c. The assisting Company personnel shall be directed to the Roster provided by such requesting team member to determine and/or confirm the restrictions on communication with the other team members. The essential team member making the request will ensure the Roster is updated by the Energy Contract Manager to include the assisting Company personnel.

d. A written record of the time, date and substance of all conversations, data and written material directly or indirectly exchanged with the Company RFP Team or the Company Self-Build Team that pertain to the RFP shall be maintained on the Communication Log. The RFP Communication Tool Kit SharePoint Site will be set up and managed by the Energy Contract Manager to provide an easy to use and understand mechanism to log and memorialize these conversations.

e. If assistance from an Unassigned Company Resource becomes more than occasional or more substantive than ancillary, ministerial or administrative services, the Unassigned Company Resource should be considered for inclusion on the team that he/she has been assisting on such basis. Additionally, the Unassigned Company Resource may also be considered for inclusion as a Shared Resource. Members of the Company RFP Team and/or Company Self-Build Team shall consult with the Company executive for resolution.

8. Communications between the Company RFP Team, the Company Self-Build Team and Company Management.

The Company RFP Team and the Company Self-Build Team will necessarily require management approval of the RFP and the Company Self-Build Team proposal. Because of the size of the Company, it may be possible that a single employee (at whatever level) (the "Approver") may have approval responsibility for matters affecting the RFP and the Company Self-Build Team proposal. Approvers in this situation must use their best judgment in making decisions reviewing and approving matters for the respective teams. The Code of Conduct must be adhered to in these situations and the Approver must not communicate matters learned from the Company RFP Team with the Company Self-Build Team.

If an Approver feels that he/she cannot manage this potential conflict, the Approver is recommended to consult with his/her immediate supervisor to determine whether such higher authority could be appointed with the task of reviewing and approving matters for a designated team, either the Company RFP Team or the Company Self-Build Team. In matters where a team of employees (including one or more Approvers) is responsible for reviewing and approving matters for the respective teams, approving employees (from whatever level, including executives) with information from reporting personnel beneath them from both the Company RFP Team and the Company Self-Build Team may consider recusing himself/herself from the decision making if such employee cannot objectively make a decision on the matter.

Finally, an Approver may be a member of the Company RFP Team and have a subordinate reporting to him/her that is a member of the Company Self-Build Team (or vice versa). In such situations, because the Code of Conduct prohibits communication between the teams, the Approver must recuse himself/herself from the decision making and request his/her manager to review and approve the matter in his/her place.

In all instances, it is possible that any particular situation above may be addressed and/or resolved by the terms and conditions of the Company's internal code of conduct implemented for all employees and consultants of the Company. As appropriate, an Approver or any other team member, Energy Contract Manager or Company executive in Charge may involve the Company's Corporate Compliance Officer for input and possible

resolution under the Company's internal corporate code of conduct.

V. WHEN THE CODE OF CONDUCT BECOMES EFFECTIVE

A. Prior to development of the requirements for any particular RFP, the Code of Conduct for that RFP will be activated. However, if the Company Self-Build Team determines at any time that it will not pursue a self-build option for a particular RFP, the Code of Conduct may be de-activated.

B. Upon the activation of the Code of Conduct, members of the Company RFP Team and the Company Self-Build Team must then conduct activities on the RFP or self-build process in compliance with the Code of Conduct. Once identified and having commenced work, no information may be shared outside the respective team members with respect to the RFP or a self-build option except through the formal communication processes outlined above.

C. Immediately upon assignment to a Company team (RFP or Self-Build), designation as a Shared Resource, or request to assist as an Unassigned Company Resource, each such employee or consultant must review this Manual, and sign the Code of Conduct Acknowledgement.

D. Within the RFP process, after a member has been assigned to a particular Company team (RFP or Self-Build), he or she will not be able to transfer to the other Company team during the pendency of any particular RFP (or stage or phase of a particular RFP). It is the responsibility of each team to fill vacant team positions with employees that have not been previously assigned as a team member for a team until the PPA negotiations have been concluded and the final contracts are executed.

E. Each employee and consultant working on the RFP shall review the Code of Conduct and sign the Code of Conduct Acknowledgement attesting to his/her compliance with the Code of Conduct until the employee is no longer working in the position, he/she was in while working on the RFP.

F. The Energy Contract Manager will be responsible for maintaining the Roster and the signed Code of Conduct Acknowledgements. The Company Executive in Charge shall be responsible for ensuring compliance with the Code of Conduct and shall have the written authority and obligation to enforce the Code of Conduct.

VI. IMMEDIATE ACTIONS UPON ACTIVATION OF THE CODE OF CONDUCT

The following items are required to be completed as soon as possible after activation of the Code of Conduct, but no later than the designated events specified for each item below.

A. Prior to development of the requirements for any particular RFP, a Roster listing employee (with their title) and consultants in their designated role; Company RFP Team, Company Self-Build Team, Shared Resource or Unassigned Company Resource. When the IO is appointed, this Roster shall be provided to him/her. The Roster shall be placed in the RFP Communication Tool Kit SharePoint Site so that any Company personnel can access the database to determine the identity of the respective teams and Shared Resources.

B. Upon the finalization of the Roster for the RFP, the Energy Contract Manager shall verify that all employees (whether full-time, part-time, temporary, or contract) and consultants involved in the competitive bidding process, such as members of the Company RFP Team, the Company Self-Build Team, Shared Resources or Unassigned Company Resources, have acknowledged receipt of the Code of Conduct and his or her responsibility to comply with the Code of Conduct by submitting the Code of Conduct Acknowledgement (with electronic acknowledgment being acceptable). If an employee or consultant is later added to a team, the Energy Contract Manager shall also verify that such employee or consultant has submitted the Code of Conduct Acknowledgment.

C. Prior to any solicitation for comments or questions to the RFP, establishment of the Company email address to accept requests for information from Proposers, including the Company Self-Build Team or any Affiliate Team.

D. Prior to the drafting of any documents for any particular RFP, establishment of the Company-secured site that houses the accessible database (such as SharePoint).

VII. WHEN THE CODE OF CONDUCT TERMINATES

- A. The Code of Conduct for a specific RFP will terminate after the following two conditions are met when:
- a. the final contract(s) for RFPs conducted under the Framework with the successful proposer(s) is/are executed, or when written notice of termination of the RFPs to be conducted under the Framework is provided by the Manager of Energy Procurement or his/her designee to the IO and the Commission, and
 - b. a certification of Code of Conduct compliance by all employees participating in the specific RFP process is submitted by affidavit by the Company Executive in Charge.

VIII. DOCUMENTATION FORMS

The following documentation forms may be utilized by those Company personnel involved in the RFP. These forms may be amended from time to time as necessary. Additional forms may also be developed as determined necessary.

- Code of Conduct Acknowledgement
- Communications Log
- Roster

IX. APPLICABILITY OF THE ATRs

Except as specifically made applicable under Section V.C.1.i of the ATRs with respect to wholesale power procurement from Affiliates, the ATRs shall not apply to RFP matters covered by the Framework, the Code of Conduct and this Procedures Manual as it relates to the Companies' interactions between the Company RFP Teams and Affiliate Teams. Reference to the ATRs in the Code of Conduct and/or this Manual are specifically

for matters outside the Companies' administration of the RFP; provided, however, that such applicability may be revised as necessary and as may be directed by the Commission for any RFP.¹

¹ See Decision and Order No. 35962, filed on December 19, 2018, in Docket 2018-0065, at 56-57.

DRAFT

REQUEST FOR PROPOSALS

FOR

VARIABLE RENEWABLE DISPATCHABLE GENERATION

PAIRED WITH ENERGY STORAGE

AND

COMMUNITY-BASED RENEWABLE ENERGY

ISLAND OF LĀNA‘I

SEPTEMBER 8, 2020

Docket No. 2015-0389

Appendix D – PowerAdvocate User Information



**Maui
Electric**



Sourcing Intelligence Quick Start for Suppliers

Logging In

1. Launch a web browser and go to www.poweradvocate.com
2. Click the orange **Login** button.
3. Enter your account **User Name** and **Password** (both are case-sensitive) and click **Login**.
4. Click the **Events** tab if it is not already displayed.

Dashboard

Your Dashboard lists the events you have been invited to. A line divides currently accessible events from others.

Click to view Events

Click to view the event's Status tab

Buyer filter

Navigation bar

Buying entity

Click numbers to view event tabs

Number of unread/total messages
Click to view the event's Messaging tab

Datasheet available

No datasheet available

- Click an event name to view its Status tab, which displays a summary of your activity and key event dates. To view specific details of an event, click the buttons 1-5 to view the corresponding tab.
- To return to the Dashboard, click **Dashboard** in the navigation bar at the top of the window.
- An event will not appear on your Dashboard until you have been added as a participant.



Downloading Bid Packages

All of the Buyer’s bid package documents (if any) are centrally stored on the PowerAdvocate Platform. To view bid documents, click “1” on your Dashboard or on the **1. Download Documents** tab from within the event.

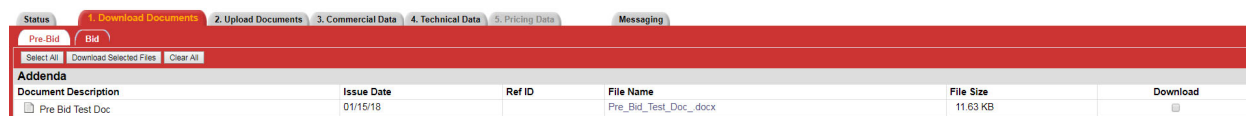

- You can access the **Bid** sub-tab after the event opens. You can access Buyer documents before the event is opened from the **Pre-Bid** sub-tab, if the Buyer utilizes this feature.
- To view or download a document, click the file name.
- To download multiple documents:
 1. Select the checkbox in the Download column for each document you wish to download or click **Select All**.
 2. Click **Download Selected Files**.

Uploading Documents

To upload your documents, click “2” on your Dashboard, or on the **2. Upload Documents** tab from within the event.



- Do not upload any files to the Pre-Bid tab.
- To upload a document to the Bid tab:
 1. Specify a **Document Type** (Reference ID can be left blank).
 2. Click **Choose File**, navigate to and select the document, and then click Open; multiple files can also be compressed into one .zip file for upload.
 3. Click **Submit Document**.



Datasheets

Datasheets (3. Commercial Data, 4. Technical Data, and 5. Pricing Data) will not be used in this RFP event. All Proposal information will be uploaded for submission through the 2. Upload Documents tab above. Buttons/tabs are grayed out (e.g., 4) if the event is not using a particular type of datasheet.

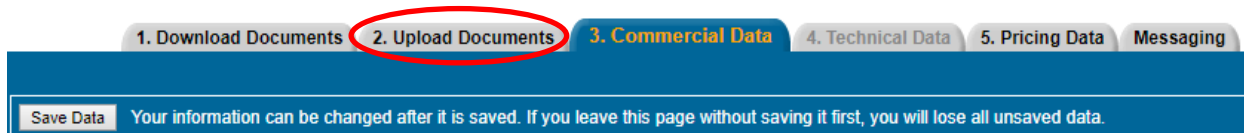

Communicating with the Bid Event Coordinator/Company Contact

Suppliers should use Email to contact the Bid Event Coordinator Company Contact while the bid event is open. In these CBRE RFPs, PowerAdvocate Messaging will not be used.

Getting More Information

- Click **Help** on the navigation bar to display online help.



- Supplier documentation can be downloaded from the online help system.
- Call PowerAdvocate Support at 857-453-5800 (Mon-Fri, 8 a.m. to 8 p.m. Eastern Time) or e-mail support@poweradvocate.com.

DRAFT

REQUEST FOR PROPOSALS

FOR

VARIABLE RENEWABLE DISPATCHABLE GENERATION

PAIRED WITH ENERGY STORAGE

AND

COMMUNITY-BASED RENEWABLE ENERGY

ISLAND OF LĀNA‘Ī

SEPTEMBER 8, 2020

Docket No. 2015-0389

*Appendix E – Mutual Confidentiality and
Non-Disclosure Agreement*



**Maui
Electric**

APPENDIX E
MUTUAL CONFIDENTIALITY AND NON-DISCLOSURE AGREEMENT
Independent Power Producers – (“IPPs”)

This Mutual Confidentiality and Non-Disclosure Agreement (this “Agreement”) is effective as of _____, 20____ (the “Effective Date”) between [INSERT NAME OF IPP], a [State of incorporation/organization] [type of entity] (“IPP”) and Hawaiian Electric Company, Inc., Maui Electric Company, Limited, and Hawaii Electric Light Company, Inc., each a Hawaii corporation (collectively, the “Companies”). In consideration of the mutual promises contained in this Agreement, including the provision of Confidential Information (as defined below) by either party to the other hereunder, and other good and valuable consideration, the receipt and sufficiency of which are hereby acknowledged, the parties agree as follows:

1. Background

The Companies have or intend to issue a Request for Proposals (“RFP”) for Community-Based renewable energy projects. The IPP has or intends to submit one or more proposals for a nominal [] MW [TYPE OF FACILITY] facility located at [LOCATION] on the island of Lāna‘i, State of Hawai‘i (“Proposal”).

In connection with the IPP’s proposed project, the Companies may conduct an interconnection requirements study (“IRS”) to establish the requirements for interconnection of the IPP’s proposed project to the Companies’ electric grid. The RFP process may also result in the award of a potential power purchase agreement, the terms of which must be agreed upon by the parties (“PPA Negotiations”). For purposes of this Agreement the term “Project” refers to the RFP, Proposal, potential IRS and PPA Negotiations.

In order to evaluate the Project, either party may from time to time provide to the other party certain Confidential Information. The parties are willing to provide such Confidential Information to each other upon the terms and conditions of this Agreement.

2. Confidential Information

Except as set forth in Section 3 (Exclusions from Confidential Information) below, “Confidential Information” means all non-public, confidential or proprietary information disclosed by either party (the “Provider”) to the other party (a “Recipient”) its affiliates and its and their directors, officers, employees, agents, advisors, consultants (including, without limitation, financial advisors, counsel and accountants) and controlling entities or individuals (collectively, “Representatives”) whether disclosed orally or disclosed or accessed in written, electronic or other form of media, and whether or not marked or otherwise identified as “confidential,” including, without limitation:

(a) all information concerning the Provider and its affiliates’, and their customers’, suppliers’ and other third parties’ past, present and future business affairs including, without limitation, finances, customer information, supplier information, products, services, designs,

processes, organizational structure and internal practices, forecasts, sales and other financial results, records and budgets, business, marketing, development, sales and other commercial information and strategies;

(b) information concerning the Companies' generation, transmission, and distribution systems (e.g., engineering and operating characteristics of the Companies' transmission lines and substations) ("Critical Infrastructure Confidential Information");

(c) the Provider's unpatented inventions (whether or not they are patentable), ideas, methods and discoveries, techniques, formulations, development plans, trade secrets, know-how, unpublished patent applications and other confidential intellectual property;

(d) all designs, specifications, documentation, components, source code, object code, images, icons, audiovisual components and objects, schematics, drawings, protocols, processes, and other visual depictions, in whole or in part, of any of the foregoing;

(e) any third-party confidential information included with, or incorporated in, any information provided by the Provider to the Recipient or its Representatives; and

(f) all notes, analyses, compilations, reports, forecasts, studies, samples, data, statistics, summaries, interpretations and other materials ("Notes") prepared by or for the Recipient or its Representatives that contain, are based on, or otherwise reflect or are derived from, in whole or in part, any of the foregoing.

3. Exclusions from Confidential Information

Except as required by applicable federal, state, or local law or regulation, the term "Confidential Information" as used in this Agreement shall not include information that:

(a) at the time of disclosure is, or thereafter becomes, generally available to and known by the public other than as a result of, directly or indirectly, any violation of this Agreement by the Recipient or any of its Representatives; provided, however, that Confidential Information shall not be disqualified as Confidential Information (i) merely because it is embraced by more general or generic information which is in the public domain or available from a third party, or (ii) if it can only be reconstructed from information taken from multiple sources, none of which individually shows the whole combination (with matching degrees of specificity);

(b) at the time of disclosure is, or thereafter becomes, available to the Recipient on a non-confidential basis from a third-party source, provided that such third party is not and was not prohibited from disclosing such Confidential Information to the Recipient by a contractual or other obligation to the Provider;

(c) was known by or in the possession of the Recipient or its Representatives, as established by documentary evidence, prior to being disclosed by or on behalf of the Provider pursuant to this Agreement;

(d) was or is independently developed by the Recipient, as established by documentary evidence, without reference to or use of, in whole or in part, any of the Provider's Confidential Information; or

(e) was or is learned of established entirely from public sources, as established by documentary evidence, without reference to or use of, in whole or in part, any of the Provider's Confidential Information.

The parties acknowledge and understand that the confidentiality obligations of this Agreement apply only to the Confidential Information shared in connection with the Project. The parties may share other information with each other under other agreements, provisions or understandings which are not related to the Project. Such information sharing shall be subject to the provisions of the agreements and confidentiality provisions associated thereto and this Agreement shall not be construed to infringe upon or apply to such agreements or provisions.

4. Non-Disclosure of Confidential Information

Unless otherwise agreed to in writing by the Provider, the Recipient agrees as follows:

(a) except as required by law, not to disclose or reveal any Confidential Information to any person or entity other than its Representatives who are actively and directly participating in the evaluation of the Project or who otherwise need to know the Confidential Information for the purpose of evaluating the Project.

(b) not to use Confidential Information for any purpose other than in connection with its evaluation of the Project or the consummation of the Project.

(c) except as required by law, not to disclose to any person or entity (other than those of its Representatives who are actively and directly participating in the evaluation of the Project or who otherwise need to know for the purpose of evaluating the Project) any information about the Project, or the terms or conditions or any other facts relating thereto, including, without limitation, the fact that discussions are taking place with respect thereto or the status thereof, or the fact that Proprietary Information has been made available to the Recipient or its Representatives.

(d) to use diligent efforts to safeguard and protect the confidentiality of the Confidential Information, including, at minimum, implementing the same commercial measures that the Recipient uses to protect its own confidential information. Before disclosing the Confidential Information to any Representative, the Recipient will inform such Representative of the confidential nature of such information, their duty to treat the Confidential Information in accordance with this Agreement and shall ensure that such Representative is legally bound by the terms and conditions of this Agreement or subject to confidentiality duties or obligations to the Recipient that are no less restrictive than the terms and conditions of this Agreement.

(e) Any provision herein to the contrary notwithstanding, the Companies may disclose Confidential Information to the State of Hawai‘i Public Utilities Commission (“Commission”) and/or the State of Hawai‘i Division of Consumer Advocacy (including their respective staffs) provided that such disclosure is made under a protective order entered in the docket or proceeding with respect to which the disclosure will be made or any general protective order entered by the Commission.

5. Required Disclosure and Notice

If the parties or any of their Representatives become legally compelled (by deposition, interrogatory, request for documents, subpoena, civil investigative demand, court order, or similar process) to disclose any of the Confidential Information, the compelled party shall undertake reasonable efforts to provide the other party with notice within three (3) business days of such requirement or advice prior to disclosure so that the other party may (a) seek a protective order or other appropriate remedy, (b) consult with the other party with respect to the compelled party taking steps to resist or narrow the scope of such requirement or advice, and/or (c) waive compliance, in whole or in part, with the terms of this Agreement. If such protective order or other remedy is not obtained, or the other party waives compliance with the provisions hereof, the compelled party agrees to furnish only that portion of the Confidential Information which it is legally required to so furnish and, at the request of the other party, to use reasonable efforts to obtain assurance that confidential treatment will be accorded such Confidential Information, it being understood that such reasonable efforts shall be at the cost and expense of the party whose Confidential Information has been sought. In any event, neither the IPP nor any of its Representatives will oppose action by the Companies to obtain an appropriate protective order or other reliable assurance that confidential treatment will be accorded the Confidential Information.

6. Return or Destruction of Confidential Information

At any time during or after the term of this Agreement, at the Provider’s written request, and in any event, upon the termination of the Agreement, the Recipient shall certify within ten (10) business days that it has destroyed all Confidential Information by using industry standard data elimination methods used to prevent unauthorized disclosure of information, and for Personally Identifiable Information (defined as personally identifiable information of individuals, and any information that may be used to track, locate or identify such individuals (or which is otherwise protected by privacy laws), including any automatically generated information (such as IP addresses and other customer identifiers) that identifies or is unique or traceable to a particular individual or computer or other electronic device capable of accessing the internet, including without limitation, name, address, telephone number, social security number, credit card account numbers, email addresses, user identification numbers or names and passwords, which is disclosed to the Recipient or its subcontractors in connection with this Agreement by the Provider, which products and services are used or intended to be used for personal, family or household purposes), such methods shall be consistent with Hawaii Revised Statutes Chapter 487-R; provided, however, that with respect to Confidential information in tangible form, the Recipient may return such Confidential Information to the Provider within ten (10) business days in lieu of destruction. The Recipient’s sole obligation with respect to the disposition of any

Notes shall be to redact or otherwise expunge all such Confidential Information from such Notes and certify to the Provider that it has so redacted or expunged the Confidential Information. Notwithstanding the foregoing, with respect to any Confidential Information stored in Recipient's disaster recovery backups or other electronic archives, Recipient is not required to destroy such Confidential Information if it would impose a material cost or burden; provided, however, such Confidential Information shall be destroyed when such archives are destroyed in accordance with Recipient's records retention policies.

7. Authority

Each party represents and warrants that it has full power and authority to enter into and perform this Agreement, and the person signing this Agreement on behalf of each has been properly authorized and empowered to enter into this Agreement, understands it and agrees to be bound by it.

8. No Representations or Warranties

Neither the Provider nor any of its Representatives make any express or implied representation or warranty as to the accuracy or completeness of any Confidential Information disclosed to the Recipient hereunder, and the Recipient agrees that it is not entitled to rely on the accuracy or completeness of any Confidential Information. Neither the Provider nor any of its Representatives shall be liable to the Recipient or any of its Representatives relating to or arising from the use of any Confidential Information or for any errors therein or omissions therefrom. Notwithstanding the foregoing, the Recipient shall be entitled to rely solely on such representations and warranties regarding Confidential Information as may be made to it in any final agreement relating to the Project, subject to the terms and conditions of such agreement.

9. No Other Obligations

Neither this Agreement nor the disclosure of the Confidential Information shall result in any obligation on the part of either party to enter into any further agreement with the other with respect to the subject matter hereof or otherwise, to purchase any products or services from the other, or to require either party to disclose any further information to the other. Nothing in this Agreement shall be deemed to constitute either party hereto as partner, agent or representative of the other party or to create any fiduciary relationship between the parties. Either party may offer products or services which are competitive with products or services now offered or which may be offered by the other. Subject to the express terms and conditions of this Agreement, neither this Agreement nor discussions and/or communications between the parties will impair the right of either party to develop, make, use, procure, and/or market any products or services, alone or with others, now or in the future, including those which may be competitive with those offered by the other. Whether or not the Project is consummated, neither party shall issue a press release or release any information to the general public concerning such transaction or the absence thereof without the express prior written consent of the other, and the parties agree that neither party will use the other's name whether by including reference to the other in any press release, list of customers advertising that its services are used by Companies or otherwise, without written authorization by the respective party's authorized representative.

10. Property Rights in Confidential Information

All Confidential Information shall remain the sole and exclusive property of the Provider and nothing in this Agreement, or any course of conduct between the parties shall be deemed to grant to the Recipient any license or rights in or to the Confidential Information of the Provider, or any part thereof. Unless otherwise expressly agreed in a separate license agreement, the disclosure of Confidential Information to the Recipient will not be deemed to constitute a grant, by implication or otherwise, of a right or license to the Confidential Information or to any patents or patent applications of the Provider.

11. Publicly Traded

The IPP acknowledges that the Companies' holding company is a publicly traded company, and that Confidential Information of the Companies may constitute material, non-public information with respect to the Companies. The IPP understands, and will advise its Representatives to whom Confidential Information of the Companies is disclosed, of the restrictions imposed by the United States securities laws on (a) the purchase or sale of securities by any person in possession of material, non-public information with respect to such securities, and (b) the communication of material, non-public information with respect to securities to a person who may purchase or sell such securities in reliance upon such information.

12. Remedies

(a) Each party acknowledges and agrees that any breach or threatened breach of this Agreement may give rise to an irreparable injury to the Provider or its Representatives, for which compensation in damages is likely to be an inadequate remedy. Accordingly, in the event of any breach or threatened breach of this Agreement by the Recipient or its Representatives, the Provider shall be entitled to seek equitable relief, including in the form of injunctions and orders for specific performance, in addition to all other remedies available at law or in equity.

(b) In the event that the Recipient learns of dissemination, disclosure, or use of the Confidential Information which is not permitted by this Agreement, the Recipient shall notify the Provider immediately in writing and shall use reasonable efforts to assist the Provider in minimizing damages from such disclosure. Such remedy shall be in addition to and not in lieu of any other rights or remedies available to the Provider at law or in equity.

13. Cumulative Remedies

No rights or remedy herein conferred upon or reserved to either party hereunder is intended to be exclusive of any other right or remedy, and each and every right and remedy shall be cumulative and in addition to any other right or remedy under this Agreement, or under applicable law, whether now or hereafter existing.

14. Notice

(a) By delivering written notice, either party may notify the other that it no longer wishes to receive or provide Confidential Information. Any further information received or provided by the party who received such notice following receipt of such notice, shall not be subject to the protection of this Agreement.

(b) All notices, consents and waivers under this Agreement shall be in writing and will be deemed to have been duly given when (i) delivered by hand, (ii) sent by electronic mail (“E-mail”) (provided receipt thereof is confirmed via E-mail or in writing by recipient), (iii) sent by certified mail, return receipt requested, or (iv) when received by the addressee, if sent by a nationally recognized overnight delivery service (receipt requested), in each case to the appropriate addresses and E-mail Addresses set forth below (or to such other addresses and E-mail addresses as a party may designate by notice to the other party):

(1) Companies:

By Mail:

Hawaiian Electric Company, Inc.
P.O. Box 2750
Honolulu, Hawaii 96840
Attn: Manager of Procurement, Renewable Acquisition Division

Delivered By Hand or Overnight Delivery:

Hawaiian Electric Company, Inc.
Central Pacific Plaza
220 South King St, 21st Floor
Honolulu, HI 96813
Attn: Manager of Procurement, Renewable Acquisition Division

By E-mail:

Hawaiian Electric Company, Inc.
Attn: Manager of Procurement, Renewable Acquisition Division
Email: renewableacquisition@hawaiianelectric.com

With a copy to:

By Mail:

Hawaiian Electric Company, Inc.
Legal Department
P.O. Box 2750
Honolulu, Hawaii 96840

Delivered By Hand or Overnight Delivery:

Hawaiian Electric Company, Inc.
American Savings Bank Tower
1001 Bishop Street, Suite 1100
Honolulu, Hawaii 96813
Attn: Legal Department

By E-mail:

Hawaiian Electric Company, Inc.
Legal Department
Email: legalnotices@hawaiianelectric.com

(2) [IPP]

By Mail:

[INSERT ADDRESS/CONTACT]

Delivered By Hand or Overnight Delivery:

[INSERT ADDRESS/CONTACT]

By E-mail:

[INSERT ADDRESS/CONTACT]

With a copy to:

By Mail:

[INSERT ADDRESS/CONTACT]

Delivered By Hand or Overnight Delivery:

[INSERT ADDRESS/CONTACT]

By E-mail:

[INSERT ADDRESS/CONTACT]

15. No Waiver

Except as otherwise provided in this Agreement, no delay or forbearance of a party in the exercise of any remedy or right will constitute a waiver thereof, and the exercise or partial exercise of a remedy or right shall not preclude further exercise of the same or any other remedy or right.

16. Governing Law

This Agreement is made under, governed by, construed and enforced in accordance with, the laws of the State of Hawaii. Any action brought with respect to the matters contained in this Agreement shall be brought in the federal or state courts located in the State of Hawaii. Each party agrees and irrevocably consents to the exercise of personal jurisdiction over each of the parties by such courts and waives any right to plead, claim or allege that the State of Hawaii is an inconvenient forum or improper venue.

17. Attorneys' Fees and Costs

If there is a dispute between the parties and either party institutes a lawsuit, arbitration, mediation or other proceeding to enforce, declare, or interpret the terms of this Agreement, then the prevailing party in such proceeding shall be awarded its reasonable attorneys' fees and costs.

18. Assignment Prohibited

This Agreement shall be binding upon and inure to the benefit of the parties hereto and their respective successors, legal representatives, and permitted assigns. Neither party shall have the right to assign any of its rights, duties or obligations under this Agreement, by operation or law or otherwise, without the prior written consent of the other party. Any purported assignment in violation of this section shall be null and void.

19. No Third Party Beneficiaries

Nothing expressed or referred to in this Agreement will be construed to give any person or entity other than the parties any legal or equitable right, remedy, or claim under or with respect to this Agreement or any provision of this Agreement. This Agreement and all of its provisions and conditions are for the sole and exclusive benefit of the parties and their successors and permitted assigns.

20. Entire Agreement

This Agreement constitutes the entire agreement between the parties relating to the subject matter hereof, superseding all prior and contemporaneous agreements, understandings or undertakings, oral or written with respect to the subject matter. Any amendment or modification of this Agreement or any part hereof shall not be valid unless in writing and signed by the Parties. Any waiver hereunder shall not be valid unless in writing and signed via by the party against whom waiver is asserted.

21. Term and Survival

This Agreement shall remain in full force and effect for a period of two (2) years from the Effective Date. All confidentiality obligations within this Agreement shall survive following expiration or termination of this Agreement.

22. Severability

If any term or provision of this Agreement, or the application thereof to any person, entity or circumstances is to any extent invalid or unenforceable, the remainder of this Agreement, or the application of such term or provision to persons, entities or circumstances other than those as to which it is invalid or unenforceable, shall not be affected thereby, and each term and provision of this Agreement shall be valid and enforceable to the fullest extent permitted by law, and the parties will take all commercially reasonable steps, including modification of the Agreement, to preserve the economic “benefit of the bargain” to both parties notwithstanding any such aforesaid invalidity or unenforceability.

23. Negotiated Terms

The parties agree that the terms and conditions of this Agreement are the result of negotiations between the parties and that this Agreement shall not be construed in favor of or against any party by reason of the extent to which any party or its professional advisors participated in the preparation of this Agreement.

24. Counterparts and Electronic Signatures

This Agreement may be executed in counterparts, each of which shall be deemed an original, and all of which shall together constitute one and the same instrument binding all parties notwithstanding that all of the parties are not signatories to the same counterparts. For all purposes, duplicate unexecuted and unacknowledged pages of the counterparts may be discarded and the remaining pages assembled as one document. The parties agree that this Agreement and any subsequent writings, including amendments, may be executed and delivered by exchange of executed copies via E-mail or other acceptable electronic means, and in electronic formats such as Adobe PDF or other formats mutually agreeable the parties which preserve the final terms of this Agreement or such writing. A party’s signature transmitted by E-mail or other acceptable electronic means shall be considered an “original” signature which is binding and effective for all purposes of this Agreement.

[Signature Page Follows]

IN WITNESS WHEREOF, each party has caused this Agreement to be executed on its behalf by a duly authorized representative, all as of the Effective Date.

HAWAIIAN ELECTRIC COMPANY, INC.

By: _____
Print Name: _____
Its: _____

MAUI ELECTRIC COMPANY, LIMITED

By: _____
Print Name: _____
Its: _____

HAWAII ELECTRIC LIGHT COMPANY, INC,

By: _____
Print Name: _____
Its: _____

“Companies”

[Insert Name of IPP]

By: _____
Print Name: _____
Its: _____

“IPP”

DRAFT REQUEST FOR PROPOSALS
FOR
VARIABLE RENEWABLE DISPATCHABLE GENERATION
PAIRED WITH ENERGY STORAGE
AND
COMMUNITY-BASED RENEWABLE ENERGY

ISLAND OF LĀNA‘I

SEPTEMBER 8, 2020

Docket No. 2015-0389

Appendix F – Description of the Pūlama Site



**Maui
Electric**

**APPENDIX F
VARIABLE RENEWABLE DISPATCHABLE GENERATION
DESCRIPTION OF THE PŪLAMA SITE**

Pūlama Site

All proposals submitted in response to this RFP must be sited at the Pūlama Site which is an undeveloped site located adjacent to Miki Road, less than 1 mile from the airport. The site is adjacent to the Company's Miki Basin Plant allowing for strategic interconnection to the switchyard. A map of the available area is included as Attachment 1 to this Appendix F. A draft copy of the proposed form of the lease and lease term sheet are included as Attachment 2 and Attachment 3, respectively, to this Appendix F. The terms of the lease will be negotiable with the landowner, Pūlama Lāna'i.

Proposers must include the cost for interconnecting into the switchyard in their Proposals.

Additional Information

Pūlama Lāna'i commissioned an Environmental Assessment (EA) of the Pūlama Site in compliance with HRS Chapter 343. Information on the EA is provided for use at Proposer's sole discretion at:

<https://luc.hawaii.gov/pending-petitions-2/boundary-amendments/a19-809-lanai-resorts-llc-dba-pulama-lanai/a19-809-lanai-resorts-llc-dba-pulama-lanai-miki-basin-enviromental-assessment-2020/>

Additionally, the following links to a few publicly available resources relating to renewable energy project permitting and collaboration from the Hawaii State Energy Office are being provided for use at Proposers' sole discretion:

Project Permitting Assistance and Resources

<http://energy.hawaii.gov/developer-investor/project-permitting-assistance-and-resources>

Provides numerous resources to support more informed and appropriate project siting and permitting, including the Permit Guide, Renewable Energy Permitting Consultants, DOH, ePermitting Portal, Renewable EnerGIS, Permitting Wizard, and the Renewable Energy Projects Directory.

Aloha Aina: A Framework for Biocultural Resource Management in Hawai'i's Anthropogenic Ecosystems

https://nmshawaiihumpbackwhale.blob.core.windows.net/hawaiihumpbackwhale-prod/media/archive/council/pdfs/aloha_aina.pdf

A framework developed by the Hawaiian Islands Humpback Whale National Marine Sanctuary Advisory Council to integrate Native Hawaiian and Western scientific management approaches toward ecosystem management. While intended for the Sanctuary, this document provides useful insight into successful collaboration in Hawaii.





APPENDIX F ATTACHMENT 2

TABLE OF CONTENTS

1. DEFINITIONS	K-2
2. TERM	K-15
3. RENT	K-16
4. ADDITIONAL PAYMENTS BY TENANT; REAL ESTATE TAXES	K-17
5. USE	K-18
6. SECURITY OF PREMISES	K-19
7. COMPLIANCE	K-19
8. MAINTENANCE AND CONSTRUCTION	K-20
9. PROHIBITED LIENS	K-21
10. HAZARDOUS SUBSTANCES	K-22
11. INDEMNIFICATION; LIABILITY OF LANDLORD	K-27
12. RIGHT OF CONTEST	K-28
13. INSURANCE	K-30
14. LOSSES AND LOSS PROCEEDS	K-34
15. LANDLORD'S TRANSFERS	K-36
16. TENANT'S TRANSFERS	K-37
17. LEASEHOLD MORTGAGE	K-37
18. QUIET ENJOYMENT; TITLE TO CERTAIN PREMISES; CERTAIN AGREEMENTS	K-40
19. EVENTS OF DEFAULT; REMEDIES	K-41
20. END OF TERM	K-46
21. NOTICES	K-48
22. NONRECOURSE	K-49
23. ADDITIONAL DELIVERIES; THIRD PARTIES	K-49
24. GUARANTY	K-50
25. ARCHAEOLOGICAL AND HISTORICAL ITEMS	K-50
26. MISCELLANEOUS	K-51
27. INTERPRETATION, EXECUTION, AND APPLICATION OF LEASE	K-52

Attachments:

Exhibit A	Legal Description
Exhibit B	Estoppel Certificate
Exhibit C	Guaranty

GROUND LEASE

BETWEEN

LĀNA‘I RESORTS, LLC

as Landlord

AND

as Tenant

FOR PREMISES LOCATED AT:

Lāna‘i City, Lāna‘i

Tax Map Key No. (2) 4-9-002:061 (por)

[This form of Ground Lease is included in the Request for Proposals for general information only. Landlord reserves the right to revise the Ground Lease to conform to, among other things, the location of the Premises and the Project.]

K-1

GROUND LEASE

THIS GROUND LEASE (the “**Lease**”) is made and entered into as of _____, 20__ (the “**Commencement Date**”), between **LĀNA‘I RESORTS, LLC**, a Hawaii limited liability company (“**Landlord**”), and _____, a _____ (“**Tenant**”).

Recitals:

(a) At the Commencement Date, Landlord owns the following real property (collectively, the “**Premises**”): (i) the unsubdivided land described in **Exhibit A**, consisting of approximately 73 acres of land (the “**Land**”) together with an easement over a roadway (the “**Roadway**”); (ii) all buildings, structures, and other improvements and appurtenances located on the Land other than any buildings, structures and other improvements or appurtenances that may have been constructed by on or behalf of Tenant prior to the commencement date; and (iii) the appurtenances and all the estate and rights of Landlord in and to the Land.

(b) Tenant and Maui Electric Company, Limited (“**MECO**”) have entered into a Power Purchase Agreement for Variable Renewable Dispatchable Generation dated as of _____, 20__ between MECO, as Company, and Tenant, as Seller, as it may be Modified (the “**Power Purchase Agreement**”).

(c) In connection with the Power Purchase Agreement, and in order to fulfill its obligations under the Power Purchase Agreement, Tenant desires to lease the Premises from Landlord, and Landlord is willing to lease the Premises to Tenant.

Agreements:

NOW, THEREFORE, for good and valuable consideration, Landlord leases and demises the Premises to Tenant, and Tenant takes and hires the Premises from Landlord, subject only to Permitted Exceptions, for the Term, upon the terms and conditions of this Lease.

1. DEFINITIONS

1.1 **Terms not Defined in Lease.** Capitalized terms not defined in this Lease have the meanings given in the Power Purchase Agreement, unless the context clearly indicates otherwise. For example, the following terms used in this Lease are defined in the Power Purchase Agreement: “Extension Term,” “Facility,” “Financing Parties” and “Good Engineering and Operating Practices.”

1.2 **Terms Defined in Lease.** The following definitions apply in this Lease.

APPENDIX F ATTACHMENT 2

“**Additional Rent**” means all sums that this Lease requires Tenant to pay Landlord or a third party, whether or not expressly called Additional Rent, except Fixed Rent.

“**Affiliate**” of any specified Person means any other Person Controlling or Controlled by or under common Control with such specified Person. “*Affiliated*” shall have the correlative meaning.

“**Application**” means any agreement, application, certificate, document, or submission (or amendment of any of the foregoing):

(a) necessary or appropriate for any Construction this Lease allows, including any application for any building permit, certificate of occupancy, utility service or hookup, easement, covenant, condition, restriction, subdivision plat, or such other instrument as Tenant may from time to time reasonably request for such Construction;

(b) to allow Tenant to obtain any abatement, deferral, or other benefit otherwise available for Real Estate Taxes;

(c) to enable Tenant from time to time to seek any Approval or to use and operate the Premises in accordance with this Lease; or

(d) otherwise reasonably necessary and appropriate to permit Tenant to realize the benefits of the Premises under this Lease.

“**Approvals**” means any and all licenses, permits (including building, demolition, alteration, use, and special permits), approvals, consents, certificates (including certificate(s) of occupancy), rulings, variances, authorizations, or amendments to any of the foregoing as shall be necessary or appropriate under any Law to commence, perform, or complete any Construction, or for the zoning, rezoning (to the extent this Lease allows), use, occupancy, maintenance, or operation of the Premises, including approval of the State Public Utilities Commission.

“**Bankruptcy Law**” means Title 11, United States Code, and any other or successor state or federal statute relating to assignment for the benefit of creditors, appointment of a receiver or trustee, bankruptcy, composition, insolvency, moratorium, reorganization, or similar matters.

“**Bankruptcy Proceeding**” means any proceeding, whether voluntary or involuntary, under any Bankruptcy Law.

“**Bankruptcy Sale**” means a sale of any property, or any interest in any property, under 11 U.S.C. §363 or otherwise in any bankruptcy, insolvency, or similar proceeding affecting the owner of such property.

“**Baseline Assessment**” means a [Phase I and/or Phase II] Environmental Report dated _____, 20__ made by _____, revealing the environmental conditions of the Land and Premises as of the Commencement Date.

“**Business Day**” means any weekday on which State-chartered banks are open to conduct regular banking business with bank personnel.

“**Casualty**” means any damage or destruction of any kind or nature, ordinary or extraordinary, foreseen or unforeseen, affecting any or all Improvements, whether or not insured or insurable.

“**Casualty Termination**” means a termination of this Lease because of a Substantial Casualty, when and as this Lease expressly allows such a termination. Tenant’s election of a Casualty Termination shall not be effective without Leasehold Mortgagee’s consent.

“**Certifying Party**” shall have the meaning set forth in Section 23.1 hereof.

“**Clean-up**” shall have the meaning set forth in Section 10.11.1 hereof.

“**Condemnation**” means: (a) any temporary or permanent taking of (or of the right to use or occupy) any Premises by condemnation, eminent domain, or any similar proceeding; or (b) any action by any Government not resulting in an actual transfer of an interest in (or of the right to use or occupy) any Premises but creating a right to compensation, such as a change in grade of any street upon which the Premises abut.

“**Condemnation Award**” means any award(s) paid or payable (whether or not in a separate award) to either party or its mortgagee after the Commencement Date because of or as compensation for any Condemnation, including: (a) any award made for any improvements that are the subject of the Condemnation; (b) the full amount paid or payable by the condemning authority for the estate that is the subject of the Condemnation, as determined in Condemnation; (c) any interest on such award; and (d) any other sums payable on account of such Condemnation, including for any prepayment premium under any mortgage.

“**Condemnation Effective Date**” means, for any Condemnation, the first date when the condemning authority has acquired title to or possession of any Premises subject to the Condemnation.

“**Confidential Information**” shall have the meaning set forth in Section 26.1 hereof.

“**Construction**” means any alteration, construction, demolition, development, expansion, reconstruction, redevelopment, repair, Restoration, or other work affecting any Improvements, including the Facility and any other new construction.

APPENDIX F ATTACHMENT 2

“**Contest**” shall have the meaning set forth in Section 12.1 hereof.

“**Contest Conditions**” shall have the meaning set forth in 12.1 hereof.

“**Contest Security**” shall have the meaning set forth in 12.1.1 hereof.

“**Control**” means possession, directly or indirectly, of the power to direct or cause the direction of the management and policies of such Person, whether by ownership of Equity Interests, by contract, or otherwise.

“**County**” means the County of Maui.

“**CPI**” means the United States Department of Labor, Bureau of Labor Statistics “Consumer Price Index” for Urban Wage Earners and Clerical Workers (CPI-W) published for Honolulu, with a base of 1982-1984 = 100. If the CPI ceases to be published, with no successor index, then the parties shall reasonably agree upon a reasonable substitute index. The CPI for any date means the CPI last published before the calendar month that includes such date.

“**CPI Adjustment Factor**” means, as of any date, the greater of (a) 1.00 or (b) the CPI for such date divided by the CPI for the Commencement Date.

“**Default**” means any Monetary Default or Nonmonetary Default.

“**Default Interest**” means interest at an annual percentage rate per annum equal to the average daily Prime Rate for the period in question plus four (4) percentage points.

“**Depository**” means an FDIC insured financial institution with its principal office in the State, designated by a Leasehold Mortgagee (or, if no Leasehold Mortgage exists, then by Landlord).

“**Discovered Items**” shall have the meaning set forth in Section 25.1 hereof.

“**Environmental Law**” means any Law regarding the following at, in, under, above, or upon the Premises: (a) air, environmental, ground water, or soil conditions; or (b) clean-up, control, disposal, generation, storage, release, transportation, or use of, or liability or standards of conduct concerning, Hazardous Substances.

“**Environmental Report**” shall have the meaning set forth in Section 10.11.1 hereof.

“**Equity Interest**” means all or any part of any direct or indirect equity or ownership interest(s) (whether stock, partnership interest, beneficial interest in a trust, membership interest, or other interest of an ownership or equity nature) in any entity at any tier of ownership that directly or indirectly owns or holds any ownership or equity interest in Tenant.

“**Estoppel Certificate**” means a statement, addressed either to Landlord or Tenant or as directed, in substantially the form of **Exhibit B**, and containing other assurances as Landlord or Tenant reasonably requests.

“**Event of Default**” shall have the meaning set forth in Section 19.1 hereof.

“**Expiration Date**” means the date when this Lease terminates or expires in accordance with its terms, whether on the Scheduled Expiration Date, by Landlord’s exercise of remedies for an Event of Default, or otherwise.

“**Facility**” means the Facility as described in the Power Purchase Agreement, as it may be Restored, modified, expanded or changed from time to time.

“**Fee Debt Service**” means all payments required from time to time under any Fee Mortgage, including principal, interest, late charges, costs of collection, reimbursement of protective advances, and any other sums any Fee Mortgage secures.

“**Fee Estate**” means Landlord’s fee estate in the Premises, including Landlord’s reversionary interest in the Premises after the Expiration Date.

“**Fee Mortgage**” means any mortgage, collateral assignment, or other lien (as modified from time to time) encumbering all or part of the Fee Estate.

“**Fee Mortgagee**” means a holder of a Fee Mortgage (and its successors and assigns).

“**Fixed Rent**” shall have the meaning set forth in Section 3.1 hereof.

“**Foreclosure Event**” means any: (a) foreclosure sale (or assignment in lieu of foreclosure, Bankruptcy Sale, or similar transfer) affecting the Leasehold Estate; or (b) Leasehold Mortgagee’s exercise of any other right or remedy under a Leasehold Mortgage (or applicable Law) that divests Tenant of its Leasehold Estate.

“**GET**” shall have the meaning set forth in Section 4.8 hereof.

“**Government**” means each and every governmental agency, authority, bureau, department, quasi-governmental body, or other entity or instrumentality having or claiming jurisdiction over the Premises (or any activity this Lease allows), including the United States government, the State and County governments and their subdivisions and municipalities, and all other applicable governmental agencies, authorities, and subdivisions thereof. “Government” shall also include any land use commission, planning commission, board of standards and appeals, department of buildings, city council, zoning board of appeals, or similar body having or claiming jurisdiction over the Premises or any activities on or at the Premises.

“**Guarantor**” means _____.

“Hazardous Substances” includes flammable substances, explosives, radioactive materials, asbestos, asbestos-containing materials, polychlorinated biphenyls, chemicals known to cause cancer or reproductive toxicity, pollutants, contaminants, hazardous wastes, medical wastes, toxic substances or related materials, petroleum and petroleum products, and any “hazardous” or “toxic” material, substance or waste that is defined by those or similar terms or is regulated as such under any Law, including any material, substance or waste that is: (a) defined as a “hazardous substance” under Section 311 of the Water Pollution Control Act (33 U.S.C. §1317), as amended; (b) defined as a “hazardous waste” under Section 1004 of the Resource Conservation and Recovery Act of 1976, 42 U.S.C. §6901, et seq., as amended; (c) defined as a “hazardous substance” or “hazardous waste” under Section 101 of the Comprehensive Environmental Response, Compensation and Liability Act of 1980, as amended by the Superfund Reauthorization Act of 1986, 42 U.S.C. §9601 et seq. or any so-called “superfund” or “superlien” law; (d) defined as a “pollutant” or “contaminant” under 42 U.S.C. §9601(33); (e) defined as “hazardous waste” under 40 C.F.R. Part 260; (f) defined as a “hazardous chemical” under 29 C.F.R. Part 1910; or (g) subject to any other Law regulating, relating to or imposing obligations, liability or standards of conduct concerning protection of human health, plant life, animal life, natural resources, property or the enjoyment of life or property free from the presence in the environment of any solid, liquid, gas, odor or any form of energy from whatever source.

“Hazardous Substances Claims” means (a) any actual, alleged or threatened Hazardous Substances Discharge; (b) any and all enforcement, cleanup, removal, mitigation, remediation or other Government actions instituted, contemplated or threatened pursuant to Environmental Law affecting the Premises; and (c) all claims made or threatened by any third party against Tenant or the Premises relating to damage, contribution, cost recovery, compensation, loss or injury resulting from any Hazardous Substances.

“Hazardous Substances Discharge” means any deposit, discharge, generation, release, or spill of Hazardous Substances that occurs at or from the Premises, or into the Land, or that arises at any time from the use, occupancy, or operation of the Premises or any activities conducted therein or any adjacent or nearby real property, or resulting from seepage, leakage, or other transmission of Hazardous Substances from other real property to the Land, whether or not caused by a party to this Lease and whether occurring before or after the Commencement Date.

“Immaterial Loss” means a Casualty or Condemnation whose estimated cost to Restore or value does not exceed \$100,000.00, adjusted annually by the CPI Adjustment Factor.

“Improvements” means all buildings, structures, and other improvements and appurtenances located or to be located on the Land from time to time, including the Facility and the landscape buffer described in Section 8.3.

“**Indemnify**” means, where this Lease states that any Indemnitor shall “Indemnify” any Indemnitee from, against, or for a particular matter (the “**Indemnified Risk**”), that the Indemnitor shall indemnify the Indemnitee and defend and hold the Indemnitee harmless from and against any and all loss, cost, claims, liability, penalties, judgments, damages, and other injury, detriment, or expense (including Legal Costs, interest and penalties) that the Indemnitee suffers or incurs: (a) from, as a result of, or on account of the Indemnified Risk; or (b) in enforcing the Indemnitor’s indemnity. Counsel retained by Indemnitor to fulfill its obligation to defend Indemnitee(s) shall be subject to Indemnitee’s approval, not to be unreasonably withheld.

“**Indemnitee**” means any party entitled to be Indemnified under this Lease and its agents, directors, employees, Equity Interest holders, mortgagees, and officers.

“**Indemnitor**” means a party that agrees to Indemnify any other Person.

“**Initial Term**” shall have the meaning set forth in Section 2.1 hereof.

“**Insubstantial Condemnation**” means any Condemnation except a Substantial Condemnation, a Temporary Condemnation, or an Immaterial Loss.

“**Land Value**” means, as of the date of a PPA Disconnect or commencement of a Holding Over under Sections 10.11.5, 19.6, or 20.2 hereof, whichever is applicable, the fair market value of the Land as determined by Landlord in good faith. The fair market value of the Land means the amount that a willing buyer would pay a willing seller for the Land, neither being under a particular compulsion to buy or to sell, each fully aware of all applicable facts about the Land, and assuming a reasonable marketing period, considered as if the Land were vacant and clear of any structures or excavations, and free and clear of all leases (including this Lease), taking into account then-current general economic conditions; costs of construction; sales of comparable parcels; the real estate marketplace; and all other conditions as in effect on the determination date that may reasonably be considered in determining the fair market value of the Land. Land Value shall otherwise be determined in accordance with prevailing standards of appraisal practice at the time of determination.

“**Landlord**” initially means the Landlord named in the opening paragraph of this Lease. After every transfer of the Fee Estate, “Landlord” means only the owner(s) of the Fee Estate at the time in question. If any former Landlord no longer has any interest in the Fee Estate or a Transfer of the Fee Estate occurs, the Transferor (including a Fee Mortgagee, or anyone acting for a Fee Mortgagee, that has acquired and then disposed of the Fee Estate) shall be and hereby is entirely freed and relieved of all obligations of Landlord under this Lease accruing from and after the date of such Transfer.

“**Laws**” means all laws, ordinances, requirements, orders, proclamations, directives, rules, and regulations of any Government affecting the Premises, this Lease, or any Construction in any way, including any use, maintenance, taxation, operation, or occupancy of, or environmental conditions affecting, the Premises, or relating to any

State or County land use and zoning, any Real Estate Taxes, or otherwise relating to this Lease or any party's rights and remedies under this Lease, or any Transfer of any of the foregoing, whether in force at the Commencement Date or passed, enacted, or imposed at some later time, subject in all cases, however, to any applicable waiver, variance, or exemption.

"Lease Impairment" means Tenant's: (a) canceling, Modifying, restating, surrendering, or terminating this Lease, including upon Loss; (b) consenting, or failing to object, to a Bankruptcy Sale of any Premises; (c) determining that a Total Loss has occurred; (d) exercising any right to treat this Lease as terminated under 11 U.S.C. §365(h)(1)(A)(i) or any comparable provision of Law; (e) subordinating this Lease or the Leasehold Estate to any other estate or interest in the Premises; or (f) waiving any term(s) of this Lease.

"Lease Termination Notice" means a Notice stating this Lease has been terminated, and describing in reasonable detail any uncured Defaults.

"Lease Year" means: (a) the twelve calendar months starting on the first day of the first full calendar month after the Commencement Date; and (b) every subsequent period of twelve calendar months during the Term.

"Leasehold Estate" means Tenant's leasehold estate, and all of Tenant's rights, privileges, and Pre-Emptive Rights, under this Lease, upon and subject to all the terms and conditions of this Lease, and any direct or indirect interest in such leasehold estate.

"Leasehold Mortgage" means any mortgage, collateral assignment, or other lien (as modified from time to time) encumbering this Lease and the Leasehold Estate, made in connection with permitted financing under the Power Purchase Agreement to a Financing Party under the Power Purchase Agreement. A Leasehold Mortgage shall not attach to the Fee Estate.

"Leasehold Mortgagee" means a holder of a Leasehold Mortgage (and its successors and assigns), provided: (a) it is a Financing Party under the Power Purchase Agreement; (b) it is not an Affiliate of Tenant; and (c) Landlord has received notice of its name and address and a copy of its Leasehold Mortgage.

"Legal Costs" of any Person means all reasonable costs and expenses such Person incurs in any legal proceeding, including appeals (or other matter for which such Person is entitled to be reimbursed for its Legal Costs), including reasonable attorneys' fees, court costs, and expenses, and in or as a result of any Bankruptcy Proceeding.

"Loss" means a Casualty or Condemnation affecting the Premises.

"Loss Proceeds" means any Property Insurance Proceeds or Condemnation Award paid or payable for a Loss.

“**Management Meeting**” shall have the meaning set forth in Section 14.7.1 hereof.

“**Market Value**” of the Land or the Facility means, as of any date of determination, the present fair market value of such estate or improvement (including the fair market value of the rights of the holder of such estate in and to any improvements) as of such date, considering: (a) as if no Loss had occurred; (b) without adjusting for any expectation of any Loss; and (c) as if the Leasehold Estate had been terminated. Market Value shall be determined independently of, and without regard to, any valuation established in a Condemnation unless Tenant Notifies Landlord otherwise. Any such Notice shall not be effective without Leasehold Mortgagee’s consent.

“**Memorandum of Lease**” means a memorandum of this Lease, in recordable form, setting forth following provisions of this Lease: (a) all information any Law requires; (b) the Term of the Lease; (c) any grant of a power of attorney; and (d) such other provisions, except the amount or means of determining Rent, as either party reasonably desires.

“**Modification**” or “**Modify**” means any abandonment, amendment, cancellation, discharge, extension, modification, rejection, renewal, replacement, restatement, substitution, supplement, surrender, termination, or waiver of a specified agreement or document, or of any of its terms or provisions, or the acceptance of any cancellation, rejection, surrender, or termination of such agreement, document, or terms.

“**Monetary Default**” means Tenant’s failure to pay any Rent or other money (including Real Estate Taxes and insurance premiums) when and as this Lease requires.

“**New Lease**” means a new lease of the Premises and related customary documents such as a memorandum of lease and a deed of Improvements. Any New Lease shall: (a) commence immediately after this Lease terminated; (b) continue for the entire remaining term of this Lease, as if no termination had occurred; (c) give New Tenant the same rights to Improvements that this Lease gave Tenant; (d) have the same terms, and the same priority, as this Lease, subject to any subsequent written amendments made with Leasehold Mortgagee’s consent; and (e) require New Tenant to cure, with reasonable diligence and continuity, within a reasonable time, all Defaults (except Tenant-Specific Defaults) not otherwise cured or waived.

“**New Tenant**” means Leasehold Mortgagee or its designee or nominee, and any of their successors and assigns.

“**Nonmonetary Default**” means Tenant’s: (a) failure to comply with any affirmative or negative covenant or obligation in this Lease, except a Monetary Default; or (b) breach of any representation or warranty (as of the date made or deemed made).

“**Notice**” or “**Notify**” means any consent, demand, designation, election, notice, or request relating to this Lease, including any Notice of Default. Notices shall be

delivered, and shall become effective, only in accordance with the “Notices” Article of this Lease.

“**Notice of Default**” means any Notice claiming or giving Notice of a Default or alleged Default.

“**Notice of Intent to Cure**” means any Notice claiming or giving Notice of a Leasehold Mortgagee’s intent to cure a Default under this Lease.

“**Permitted Exceptions**” means only: (a) the recorded title exceptions affecting the Fee Estate and prior to this Lease as of the Commencement Date, listed as exceptions in Tenant’s leasehold policy of title insurance for this Lease; (b) any title exceptions (including Subleases) caused by Tenant’s acts or omissions, consented to or requested by Tenant, or resulting from Tenant’s Default; (c) any Application made at Tenant’s request; (d) this Lease and its terms and provisions; and (e) any state of facts an accurate survey would show.

“**Phase I Environmental Assessment**” means an environmental assessment and report prepared by a qualified environmental professional reasonably acceptable to Landlord that meets or exceeds the minimum requirements outlined in the then current version of the American Society of Testing and Materials Standard E 1527-00 (Standard Practice of Environmental Site Assessments: Phase I Environmental Site Assessment Process).

“**Phase II Environmental Assessment**” means an environmental assessment and report prepared by a qualified environmental professional reasonably acceptable to Landlord that goes beyond the investigations of a Phase I Environmental Assessment and involves sampling and testing of the Premises, including (a) an asbestos survey conducted according to the standards of the Asbestos Hazard Emergency Response Act protocol; (b) testing of any transformers on the Premises for PCBs; (c) testing for lead based paints; (d) soil and groundwater sampling to measure the effect of any actual or suspected release or discharge of Hazardous Substances on the Premises; and (e) such other sampling and testing reasonably necessary to determine the environmental condition of the Premises.

“**Permitted Use**” means the construction, maintenance and operation of the Facility, consistent with Good Engineering and Operating Practices.

“**PPA Disconnect**” means any period of time during which the Power Purchase Agreement remains in effect but because of a Tenant Event of Default under the Power Purchase Agreement MECO is not purchasing power from Tenant.

“**PPA Restoration**” means either (a) the Power Purchase Agreement is reinstated following a termination of the Power Purchase Agreement; or (b) Tenant’s Event of Default under the Power Purchase Agreement has been cured and MECO is purchasing

power from Tenant (or its permitted successor assignee) in accordance with the Power Purchase Agreement.

“Person” means any association, corporation, Government, individual, joint venture, joint-stock company, limited liability company, partnership, trust, unincorporated organization, or other entity of any kind. (This does not limit any Transfer restriction.)

“Prime Rate” means the “prime rate” of interest, as published from time to time by The Wall Street Journal in the “Money Rates” section of its Western Edition Newspaper (or the average prime rate if a high and a low prime rate are therein reported). The Prime Rate shall change without notice with each change in the prime rate reported by The Wall Street Journal, as of the date such change is reported. Any such rate is a general reference rate of interest, may not be related to any other rate, may not be the lowest or best rate actually charged by any lender to any customer or a favored rate and may not correspond with future increases or decreases in interest rates charged by lenders or market rates in general.

“Prohibited Lien” means any mechanic’s, vendor’s, laborer’s, or material supplier’s statutory lien or other similar lien arising from work, labor, services, equipment, or materials supplied, or claimed to have been supplied, to Tenant (or anyone claiming through Tenant), but only if such lien attaches (or may attach upon termination of this Lease) to the Fee Estate.

“Property Insurance Proceeds” means net proceeds (after reasonable costs of adjustment and collection, including Legal Costs) of any property insurance policies covering the Premises, when and as received by Landlord, Tenant, Depository, or any Fee Mortgagee or Leasehold Mortgagee, excluding proceeds of Tenant’s business interruption insurance in excess of Rent.

“PSC” shall have the meaning set forth in Section 4.8 hereof.

“Real Estate Taxes” means all general and special real estate taxes (including sales taxes, use taxes, and the like), conveyance taxes, transfer taxes, assessments, municipal water and sewer rents, rates and charges, excises, levies, license and permit fees, fines, penalties and other governmental charges and any interest or costs with respect thereto, general and special, ordinary and extraordinary, foreseen and unforeseen, of any kind and nature whatsoever that at any time before or during the Term and applicable to the Term or any part of it may be assessed, levied, imposed upon, or become due and payable out of or in respect of, or charged with respect to or become a lien on, the Premises, or the sidewalks or streets in front of or adjoining the Premises, or any vault, passageway or space in, over or under such sidewalk or street, or any other appurtenances of the Premises, or other facility used in the operation thereof, or the rent or income received therefrom, or any use or occupancy thereof.

If at any time during the Term the method of taxation prevailing at the Commencement Date shall be altered so that any new tax, assessment, levy (including any municipal, state or federal levy), imposition, or charge, or any part thereof, shall be measured by or be based in whole or in part upon the Premises and imposed upon Landlord, then all such new taxes, assessments, levies, Real Estate Taxes, or charges, or the part thereof to the extent that they are so measured or based, shall be deemed to be included within the term “Real Estate Taxes,” to the extent that such Real Estate Taxes would be payable if the Premises were the only property of Landlord subject to such Real Estate Taxes.

“**Remaining Premises**” means any Premises that Landlord continues to own after a Total Loss.

“**Removal Period**” shall have the meaning set forth in Section 20.2 hereof.

“**Rent**” means Fixed Rent, Variable Rent and Additional Rent.

“**Requesting Party**” shall have the meaning set forth in Section 23.1 hereof.

“**Restoration**” and “**Restore**” means, after a Loss, the alteration, clearing, rebuilding, reconstruction, repair, replacement, restoration, and safeguarding of the damaged or remaining Improvements, substantially consistent with their condition before the Loss, subject to such Construction as Tenant shall perform in conformity with this Lease, subject to any changes in Law that would limit the foregoing.

“**Restoration Funds**” means any Loss Proceeds (and deposits by Tenant) to be applied to Restoration.

“**Scheduled Expiration Date**” means the date upon which the Power Purchase Agreement terminates, i.e., the end of the Term (as defined in the Power Purchase Agreement) *plus* any Extension Term (defined in the Power Purchase Agreement).

“**Security Deposit**” means fifty percent (50%) of the Operating Period Security (as defined in the Power Purchase Agreement) required under the Power Purchase Agreement.

“**State**” means the State of Hawaii.

“**Sublease**” means, for the Premises, any: (a) sublease; (b) agreement or arrangement (including a concession, license, management, or occupancy agreement) allowing any Person to occupy, use or possess; (c) subsublease or any further level of subletting; or (d) Modification or assignment of (a) through (c). (Any reference to Subleases does not diminish, impair, limit, or waive any limit on Subleases.)

“**Subrent**” means all money due and payable by Subtenants under Subleases.

“**Substantial Casualty**” means a Casualty that, pursuant to Law, prevents the Premises from being Restored for the Permitted Use.

“**Substantial Condemnation**” means any Condemnation that (a) takes the entire Premises; or (b) in Tenant’s reasonable determination (with Leasehold Mortgagee’s consent) renders the remaining Premises unsuitable for the Permitted Uses.

“**Subtenant**” means any Person entitled to occupy, use, or possess any Premises under a Sublease.

“**Temporary Condemnation**” means a Condemnation of the temporary right to use or occupy all or part of the Premises.

“**Tenant-Specific Default**” means any Nonmonetary Default that by its nature relates only to, or can reasonably be performed only by, Tenant or its Affiliates.

“**Term**” means the Initial Term, as it may be extended by any Extension Term.

“**Total Loss**” means any (a) Condemnation that affects all or substantially all the Premises; or (b) Loss after which Tenant cannot legally Restore the Facility for its Permitted Use.

“**Transfer**” of any property means any of the following, whether by operation of law or otherwise, whether voluntary or involuntary, and whether direct or indirect:

(a) any assignment, conveyance, grant, hypothecation, mortgage, pledge, sale, or other transfer, whether direct or indirect, of all or any part of such property, or of any legal, beneficial, or equitable interest or estate in such property or any part of it (including the grant of any easement, lien, or other encumbrance);

(b) any conversion, exchange, issuance, modification, reallocation, sale, or other transfer of any direct or indirect Equity Interest(s) in the owner of such property by the holders of such Equity Interest(s);

(c) any transaction described in (b) affecting any Equity Interest(s) or any other interest in such property or in any such owner (or in any other direct or indirect owner at any higher tier of ownership) through any manner or means whatsoever; or

(d) any transaction that is in substance equivalent to any of the foregoing.

A transaction affecting Equity Interests, as referred to in clauses (b) through (d), shall be deemed a Transfer by Tenant even though Tenant is not technically the transferor. However, a “Transfer” shall not include any of the foregoing (provided that the other party to this Lease has received Notice thereof) relating to any Equity Interest: (a) that constitutes a mere change in form of ownership with no material change in beneficial ownership and constitutes a tax-free transaction under federal income tax law

and the State real estate transfer tax; or (b) to any Person that, as of the Commencement Date, holds an Equity Interest in the entity whose Equity Interest is being transferred.

“**Unavoidable Delay**” means delay in performing any obligation under this Lease (except payment of money) arising from or on account of any cause whatsoever beyond the obligor’s reasonable control, despite such obligor’s reasonable diligent efforts, including industry-wide strikes, labor troubles or other union activities (but only to the extent such actions affect similar premises at that time and do not result from an act or omission of the obligor), the obligor’s inability to obtain required labor or materials after commercially reasonable efforts to do so, litigation (unless caused by the obligor), Loss, accidents, Laws, governmental preemption, war, or riots. Unavoidable Delay shall exclude delay caused by the obligor’s financial condition, illiquidity, or insolvency. Any obligor claiming Unavoidable Delay shall Notify the obligee: (a) within 30 days after such obligor knows of any such Unavoidable Delay; and (b) within 10 days after such Unavoidable Delay ceases to exist. To be effective, any such Notice must describe the Unavoidable Delay in reasonable detail. Where this Lease states that performance of any obligation is subject to Unavoidable Delay(s) or words of similar import, such Unavoidable Delay(s) shall extend the time for such performance only by the number of days by which such Unavoidable Delay(s) actually delayed such performance.

“**Underground Storage Tank**” means any combination of tanks (including pipes connected to the tanks) used to contain an accumulation of Hazardous Substances, and the volume of which (including the volume of the underground pipes connected to the tanks) is ten percent or more beneath the surface of the ground.

1.3 Principles of Interpretation. A term defined in the singular may be used in the plural, and vice versa, all in accordance with ordinary principles of English grammar, which also govern all other language in this Lease. The words “include” and “including” shall be construed to be followed by the words: “without limitation.” Each of these terms shall be interpreted as if followed by the words “(or any part of it)” except where the context clearly requires otherwise: Fee Estate; Improvements; Land; Leasehold Estate; Premises; and any other similar collective noun. Every reference to any document, including this Lease, refers to such document as Modified from time to time (except, at Landlord’s option, any Modification that violates this Lease), and includes all exhibits, schedules, and riders to such document. The word “or” includes the word “and.”

1.4 Conflict between Lease and Power Purchase Agreement. To the extent there exists any conflict between the provisions of this Lease and the Power Purchase Agreement, the Power Purchase Agreement shall control.

2. TERM

2.1 Initial Term. The initial term of this Lease (the “**Initial Term**”) shall: (a) commence on the Commencement Date; and (b) end on the Scheduled Expiration Date, unless terminated sooner. If the Commencement Date is not the first (or the

Expiration Date is not the last) day of a Lease Year, then from the Commencement Date through the day before the first Lease Year (or from the day after the last Lease Year through the Expiration Date), the parties shall have all the same rights and obligations under this Lease (including regarding Rent) that they do during the first (or the last, as applicable) full Lease Year, all prorated daily.

2.2 **Automatic Termination.** Notwithstanding anything to the contrary in this Lease, this Lease shall automatically terminate upon termination of the Power Purchase Agreement, without Notice.

3. RENT

3.1 **Fixed Rent.** Tenant shall pay Landlord, without notice or demand, in lawful money of the United States of America, a fixed annual rental (the “**Fixed Rent**”) as follows:

3.1.1 \$200.00 per acre per month, upon execution of the Lease and increased to 50%, \$300.00 per acre per month, as long as the Power Purchase Agreement remains in effect upon commercial operations and adjusted annually by the CPI Adjustment Factor; or

3.1.2 10% of the Land Value per year, adjusted annually by the CPI Adjustment Factor, commencing on the date a PPA Disconnect occurs and continuing for the period a PPA Disconnect remains in effect.

If there is no longer a PPA Disconnect, and a PPA Restoration occurs, the Fixed Rent shall be restored to the rate that was effective at time of PPA Disconnect until any new PPA Disconnect occurs.

3.2 **Annual or Monthly Payment; Proration; Etc.** Tenant shall pay Fixed Rent annually in advance, otherwise Tenant shall pay Fixed Rent in equal monthly installments in advance on the first day of each month. Tenant shall pay all Rent payable to Landlord by good and sufficient check payable to Landlord or by wire transfer, at such address as Landlord shall designate from time to time.

3.3 **Variable Rent.** Tenant shall pay Landlord, without notice or demand, in lawful money of the United States of America, a variable monthly rent (the “**Variable Rent**”) as follows:

3.3.1 2.00% of the monthly gross receipts received from HECO to the Tenant per the negotiated PPA for the project.

3.4 **Additional Rent.** In addition to Fixed Rent and Variable Rent, Tenant shall pay Landlord (or the appropriate third party, as applicable), as additional rent under this Lease, all Additional Rent. Except where this Lease provides otherwise, Tenant shall

pay all Additional Rent within 15 days after receipt of an invoice and reasonable backup documentation.

3.5 **No Offsets.** Tenant shall pay all Rent without offset, defense, claim, counterclaim, reduction, or deduction of any kind whatsoever.

4. **ADDITIONAL PAYMENTS BY TENANT; REAL ESTATE TAXES**

4.1 **Landlord's Net Return.** This Lease shall constitute an absolutely "net" lease. The Fixed Rent shall give Landlord an absolutely "net" return for the Term, free of any expenses or charges for the Premises, except as this Lease expressly provides. Tenant shall pay as Additional Rent and discharge (subject to Tenant's right of Contest as this Lease expressly provides), before failure to pay creates a material risk of forfeiture or penalty, each and every item of expense, of every kind and nature whatsoever, related to or arising from the Premises, or by reason of or in any manner connected with or arising from the leasing, operation, management, maintenance, repair, use, or occupancy of, or Construction affecting the Premises.

4.2 **No Tenant Obligation.** Notwithstanding anything to the contrary in this Lease, Tenant need not pay the following items payable, accrued, or incurred by Landlord: (a) Fee Debt Service; (b) depreciation, amortization, brokerage commissions, financing or refinancing costs, management fees, or leasing expenses for the Fee Estate or the Premises; and (c) any costs or expenses that Landlord incurs in or for any Management Meeting, except to the extent that this Lease requires Tenant to pay such costs or expenses.

4.3 **Real Estate Taxes.** Tenant shall pay and discharge all Real Estate Taxes payable or accruing for all period(s) within the Term, before failure to pay creates a material risk to Landlord of forfeiture or penalty, subject however to Tenant's right of Contest as this Lease expressly provides. Tenant shall also pay all interest and penalties any Government assesses for late payment of any Real Estate Taxes, except late payment because Landlord failed to remit any payment for Real Estate Taxes (paid to Landlord by Tenant) in accordance with Tenant's reasonable instructions (provided they involve only ministerial functions) or failed to forward promptly Tenant a copy of any applicable bill that Landlord receives. In the latter case Landlord shall pay such interest and penalties. Tenant shall within a reasonable time after Notice from Landlord give Landlord reasonable proof that Tenant has paid any Real Estate Taxes that this Lease requires Tenant to pay. Tenant shall have the sole right and authority to contest Real Estate Taxes, in compliance with the Contest Conditions.

4.4 **Assessments in Installments.** To the extent Law allows, Tenant may apply to have any assessment payable in installments. Upon approval of such application, Tenant shall pay and discharge only such installments as become due and payable during the Term.

4.5 **Utilities.** Tenant shall arrange and pay for all fuel, gas, light, power, water, sewage, garbage disposal, telephone, and other utility charges, and the expenses of installation, maintenance, use, and service in connection with the foregoing, for the Premises during the Term. Landlord shall have absolutely no liability or responsibility for the foregoing.

4.6 **Security Deposit.** Concurrently with Tenant's execution of this Lease, Tenant shall deposit with Landlord the Security Deposit. Landlord shall hold the Security Deposit as security for the performance of Tenant's obligations under this Lease. If Tenant Defaults on any provision of this Lease, Landlord may, without prejudice to any other remedy it has, apply all or part of the Security Deposit to any Rent or other sum in default, any amount that Landlord may spend or become obligated to spend in exercising Landlord's rights under this Lease, or any expense, loss, or damage that Landlord may suffer because of Tenant's Default.

4.7 **Tax.** Tenant will pay to Landlord at the time and together with each payment of Rent that is subject to tax, including GET or PSC, whichever is applicable, and any other applicable tax on account of the receipt, actual or constructive, by Landlord of the rental payments, reimbursement of gross income taxes, and any other taxable gross income attributable to the Premises or this Lease, an amount which, when added to Rent (whether actually or constructively received by Landlord), shall yield to Landlord, after deduction of the tax, an amount equal to that which Landlord would have realized had no such tax been imposed. For the purposes of this Section, "GET" means the State of Hawaii general excise tax on gross income under Hawaii Revised Statutes Chapter 237, and any sales or value added taxes under any successor, similar or new federal, state or county law that may be hereafter enacted, and "PSC" means the State of Hawaii public service company tax under Hawaii Revised Statutes Chapter 239. For purpose of illustration only, the amount necessary to reimburse Landlord is as of the Commencement Date 4.1666%.

4.8 **Conveyance Tax.** Tenant shall pay the conveyance tax imposed under Hawaii Revised Statutes Chapter 247 that is due and payable upon the Commencement Date. Tenant shall provide Landlord with proof satisfactory to Landlord that the conveyance tax has been paid.

5. USE

5.1 **Permitted Use.** Tenant shall use the Premises for the Permitted Use and only for the Permitted Use. Tenant shall continuously use and operate the Premises for the Permitted Use.

5.2 **Permitted Use Unique.** Landlord has leased the Premises to Tenant solely for the purpose of Tenant's providing electrical power to MECO's system pursuant to the Power Purchase Agreement. The State Public Utilities Commission has authorized Landlord to enter into this Lease only in connection with and for the purposes of the Power Purchase Agreement. Tenant acknowledges and agrees that the Premises cannot

be used for any purpose other than the Permitted Use. Tenant waives and relinquishes any right it may have under Bankruptcy Law, in any Bankruptcy Proceeding, or otherwise to assert the Premises should be used for a purpose other than the Permitted Use.

5.3 **Access.** All access roads made available or maintained by the Landlord, providing access from the Premises to public roads shall at all times be subject to the exclusive control and management of Landlord, and Landlord shall have the right, from time to time, to establish, modify and enforce reasonable rules and regulations with respect to the access and Tenant agrees to comply with all of Landlord's rules and regulations with respect to the access.

5.4 **Exclusive Control.** Tenant shall have exclusive control, possession, occupancy, use, and management of the Premises, subject only to Permitted Exceptions.

5.5 **Operational Costs.** Tenant shall timely pay and discharge all fees, costs, and expenses related to or arising from the management or operation of the Premises and the provision of services to the Premises.

6. SECURITY OF PREMISES

6.1 **Secured Facility.** Tenant shall secure the Facility and prevent access to the Facility by unauthorized personnel in the same manner or higher as MECO secures its power generating facilities in the County. Notwithstanding MECO's then current security procedures for its own facilities, Landlord may require Tenant to maintain personnel on the Premises 24 hours a day 7 days a week to monitor the security and safety of the Premises and Facility.

6.2 **Limited Access to Premises.** Tenant will maintain barriers on the Premises to prevent unauthorized persons or vehicles from entering or crossing through the Premises and adjacent lands owned or operated by Landlord.

6.3 **Personnel.** Tenant shall conduct security and background checks on all Tenant employees, independent contractors, and other persons who are regularly allowed access to the Facility and shall require all such persons to take periodic drug tests. Tenant shall not allow on the Premises any persons who do not pass such security checks or drug tests.

7. COMPLIANCE

7.1 **Generally.** Tenant shall during the Term, at Tenant's expense, in all material respects, subject to Tenant's right of Contest: (a) comply with all Laws and Permitted Exceptions; (b) comply with the Land Use Conditions, if any; (c) procure all Approvals required by Law other than the approval of the Power Purchase Agreement by the State Public Utilities Commission; and (d) comply with all Approvals.

7.2 **Power Purchase Agreement.** Tenant shall during the Term, at Tenant's expense, in all material respects, comply with Tenant's obligations under the Power Purchase Agreement.

7.3 **Notice of Inspections.** Tenant shall give Landlord Notice of any proposed inspection of the Premises or the Facility by any Government agency immediately upon Tenant's receipt of notice of such inspection.

7.4 **Copies of Notices.** Landlord shall promptly give Tenant a copy of any notice of any kind regarding the Premises or any Real Estate Taxes (including any bill or statement), and any notice of nonrenewal or threatened nonrenewal of any Approval that Landlord receives from any Government, utility company, insurance carrier, or insurance rating bureau.

8. MAINTENANCE AND CONSTRUCTION

8.1 **Obligation to Maintain.** Except to the extent that (a) this Lease otherwise expressly provides or allows or (b) Tenant is performing Construction in compliance with this Lease, Tenant shall during the Term keep and maintain the Premises in good order, condition, and repair, subject to Loss (governed by other provisions of this Lease), reasonable wear and tear, and any other condition that this Lease does not require Tenant to repair. Tenant's obligation to maintain the Premises includes an obligation to make all repairs that the Premises (including plumbing, heating, air conditioning, ventilating, electrical, lighting, fixtures, walls, building systems, ceilings, floors, windows, doors, plate glass, skylights, landscaping, drainage, retention basins, bridges, driveways, site improvements, curb cuts, parking lots, fences and signs located in, on or at the Premises, together with any sidewalks and streets adjacent to the Premises) may require by Law from time to time during the Term, whether structural or nonstructural, foreseen or unforeseen, capital or operating. Tenant shall remove trash and debris from the Premises and the adjoining sidewalk, and maintain them in a reasonably clean condition.

8.2 **Acceptance of Premises.** Tenant acknowledges that it has, or has had the opportunity, to inspect carefully the Premises, and accepts the Premises in **AS IS** condition **WITH ALL FAULTS**. Tenant further acknowledges that neither Landlord nor its agents or employees have made any representations or warranties of any kind whatsoever as to the suitability or fitness of the Premises for the conduct of Tenant's business or for any other purpose, nor has Landlord or its agents or employees agreed to make any repairs, undertake any alterations, or construct any improvements to the Premises or with respect to the Premises.

8.3 **Construction.** At Tenant's sole cost and expense, Tenant shall construct the Facility in accordance with the requirements of the Power Purchase Agreement. Tenant shall not commence Construction until it has the applicable necessary Approvals. Prior to commencement of any Construction, Tenant shall cause each entity involved in such Construction, who is a direct contractor of Tenant and who has mechanic lien rights under Chapter 507 of the Hawaii Revised Statutes, to deliver to Landlord a performance

and payment bond in a form acceptable to Landlord and from a surety reasonably acceptable to Landlord, covering the faithful performance of such entity's contract with the Tenant and the payment of all obligations arising thereunder, and naming Landlord as an obligee. Tenant shall complete Construction of the Facility within the time periods required by the Power Purchase Agreement. Tenant shall pay for all Construction when and as required by the parties that perform such Construction. All Improvements that Tenant constructs on the Land shall become part of the Premises.

8.4 Plans and Specifications. To the extent that Tenant obtains plans and specifications or surveys (including working plans and specifications and "as-built" plans and specifications and surveys) for any Construction, Tenant shall promptly upon Landlord's request give Landlord a copy, subject to the terms of any agreement between Tenant and the applicable architect, engineer, or surveyor. Tenant shall exercise reasonable efforts to cause its agreements with such professionals to permit these deliveries, which are for Landlord's information only except to the extent, if any, this Lease otherwise expressly states.

8.5 Applications. Upon Tenant's request, Landlord shall, without cost to Landlord, promptly join in and execute any Application as Tenant reasonably requests, provided that: (a) such Application is in customary form and imposes no material obligations (beyond obligations ministerial in nature or merely requiring compliance with Law) upon Landlord; (b) no uncured Event of Default exists; and (c) Tenant reimburses Landlord's Legal Costs. Promptly upon Tenant's request and without charge (except reimbursement of Landlord's Legal Costs), Landlord shall furnish all information in its possession that Tenant reasonably requests for any Application.

9. PROHIBITED LIENS

9.1 Tenant's Covenant. If a Prohibited Lien is filed, Tenant shall, within 30 days after receiving Notice from Landlord of such filing (but in any case within 15 days after Landlord Notifies Tenant of commencement of any application for a mechanic's lien or foreclosure proceedings), commence appropriate action to cause such Prohibited Lien to be paid, discharged, bonded, or cleared from title. Tenant shall thereafter prosecute such action with reasonable diligence and continuity. If Landlord receives notice of any such filing, then Landlord shall promptly Notify Tenant. Nothing in this Lease shall be construed to: (a) limit Tenant's right of Contest; or (b) obligate Tenant regarding any lien that results from any act or omission by Landlord.

9.2 Protection of Landlord. Notice is hereby given that Landlord shall not be liable for any labor or materials furnished or to be furnished to Tenant upon credit, and that no mechanic's or other lien for any such labor or materials shall attach to or affect the Fee Estate. Nothing in this Lease shall be deemed or construed in any way to constitute Landlord's consent or request, express or implied, by inference or otherwise, to any contractor, subcontractor, laborer, equipment or material supplier for the performance of any labor or the furnishing of any materials or equipment for any

construction, nor as giving Tenant any right, power or authority to contract for, or permit the rendering of, any services, or the furnishing of any materials that would give rise to the filing of any liens against the Fee Estate. Tenant shall Indemnify Landlord against any claims arising out of Construction undertaken by Tenant or anyone claiming through Tenant, and against all Prohibited Liens.

10. HAZARDOUS SUBSTANCES

10.1 **Baseline Assessment.** Tenant has obtained a Baseline Assessment and has provided Landlord with a copy of the results of the Baseline Assessment. Any Hazardous Substances not disclosed in the Baseline Assessment and subsequently discovered on the Premises shall be presumed to be present as a result of Tenant's use and occupancy of the Premises during the Term, unless Tenant shall prove, by clear and convincing proof, that the Hazardous Substances: (a) were present on the Premises prior to the Term; (b) migrated onto the Premises as the result of the activities of a third party; or (c) are present on the Premises as the result of Landlord's improper actions.

10.2 **Compliance with Environmental Law.** Tenant shall keep and maintain the Premises, including the Land, the air above the Land, the surface and run-off water on the Land, and the groundwater under the Land, in compliance with, and shall not cause or permit the Premises or any portion of the Premises to be in violation of, any Environmental Law.

10.3 **Use of Hazardous Substances.** Tenant shall not cause or allow any Hazardous Substances Discharge, except (a) in the ordinary course of Tenant's business (b) in accordance with the instructions of the manufacturer and for the purpose described in such instructions, and (c) in strict compliance with all applicable Environmental Law. Tenant shall not install any Underground Storage Tank on, within, under or about the Premises without first obtaining Landlord's written approval. Tenant shall not accept hazardous waste (as defined under any Environmental Law) generated off the Premises for any purpose, including treatment, storage or disposal.

10.4 **List of Hazardous Substances.** On the Commencement Date and on each anniversary of the Commencement Date, and at any other time Landlord requests, Tenant shall provide Landlord with a written list identifying any Hazardous Substances then used, stored, or maintained upon the Premises, the use and approximate quantity of each such material, a copy of any material safety data sheet (MSDS) issued by the manufacturer thereof, written information concerning the removal, transportation, and disposal of the same, and such other information as Landlord may reasonably require or as may be required by Law.

10.5 **Notice of Disturbance of Any Hazardous Substances.** Tenant shall provide Landlord 30 days' prior Notice before commencing any activities, including repair or remodeling of the Facility or the Premises or installation or removal of any personal property from the Premises, which could result in the disturbance of any Hazardous Substances. Together with such Notice, Tenant shall advise Landlord of

protective measures to be taken by Tenant to ensure that Hazardous Substances shall not be released and to ensure compliance with Environmental Law. Tenant shall comply with all reasonable conditions (including adequate assurance of financial resources to comply with Environmental Law) that may be imposed by Landlord in connection with Tenant's proposed activities.

10.6 Hazardous Substances Claims. Tenant shall immediately Notify Landlord of: (a) any Hazardous Substances Claims; or (b) Tenant's discovery of any occurrence or condition of the Premises which could subject Tenant or Landlord to any liability, or restrictions on ownership, occupancy, transferability or use of the Premises under any Environmental Law.

10.7 Remediation and Removal. Except for the use of Hazardous Substances permitted by this Lease, Tenant shall cause any Hazardous Substances Discharge to be: (a) remediated on-site in accordance with applicable Environmental Law; or (b) removed from the Premises for remediation or disposal and to be transported solely by duly licensed Hazardous Substances transporters to duly licensed disposal facilities for final disposition to the extent required by and in accordance with applicable Environmental Law. Tenant shall deliver to Landlord copies of any hazardous waste manifest reflecting the proper disposition of such Hazardous Substances. Except in emergencies or as otherwise required by law, Tenant shall not take any remedial or removal action in response to a Hazardous Substances Discharge without first Notifying Landlord.

10.8 Proceedings on Hazardous Substances Claims; Indemnity. Tenant shall not enter into any legal proceeding or other action, settlement, consent decree or other compromise with respect to any Hazardous Substances Claims without first Notifying Landlord of Tenant's intention to do so and affording Landlord the opportunity to join and participate as a party if Landlord so elects in such proceedings. Tenant shall be solely responsible for and shall Indemnify the Indemnitee against any Hazardous Substances Claims, including: (a) the costs of any required or necessary removal, repair, cleanup or remediation of the Premises, and the preparation and implementation of any closure, removal, remedial or other required plans; and (b) all reasonable costs and expenses incurred by Landlord in connection therewith, including Legal Costs.

10.9 Assurance of Performance.

10.9.1 Landlord's Phase II Environmental Assessment. Landlord may, but shall not be required to, engage such contractors as Landlord determines to be appropriate to perform from time to time a Phase II Environmental Assessment, including environmental sampling and testing, of: (i) the Premises, the surrounding soil and any adjacent areas, and any ground water located under or surface water located adjacent to the Premises or any adjoining property; (ii) Tenant's compliance with all Environmental Law and the provisions of this Lease; and (iii) the provisions made by Tenant for carrying out any removal or remedial action that may be required by reason of the nature of Tenant's business and operations on the Premises.

10.9.2 Cost of Assessment. All costs and expenses incurred by Landlord in connection with any such Phase II Environmental Assessment shall be paid by Landlord, except that if any such Phase II Environmental Assessment shows that: (i) the environmental condition of the Premises has materially declined in comparison to the Baseline Assessment; (ii) Tenant has failed to comply with the provisions of this Lease with respect to Hazardous Substances; (iii) the Premises (including surrounding soil and any underlying groundwater or adjacent surface water) has become contaminated due to operations or activities not attributable to Landlord; or (iv) an event that is the basis for a Hazardous Substances Claim occurred during the Term, then all of the costs and expenses of such assessment shall be paid by Tenant.

10.9.3 Conducting Assessment. Each Phase II Environmental Assessment shall be conducted: (a) only after advance Notice of such assessment has been provided to Tenant at least 10 days' prior to the date of the assessment; and (b) in a manner reasonably designed to minimize the interruption of Tenant's operations and use of the Premises. Landlord shall repair any substantial damage to the Premises or to Tenant's property that is directly caused by the Phase II Environmental Assessment.

10.10 Tenant's Obligations Prior to and Upon Surrender.

10.10.1 Tenant's Phase I and Phase II Environmental Assessment Deposit. No later than 18 months prior to the Scheduled Expiration Date, Tenant shall deposit with Landlord a sum equal to the then current estimated cost of conducting a Phase I and Phase II Environmental Assessment of the Premises. Landlord shall hold such sum for Tenant and shall apply or reimburse such sum as provided in this section.

10.10.2 Tenant's Phase I (or Phase II) Environmental Assessment.

(a) No later than the beginning of the last year of the Term, or immediately upon earlier termination of the Term, Tenant, at Tenant's sole cost and expense shall cause a Phase I Environmental Assessment of the Premises to be conducted, or provide Landlord with a report based upon a Phase I Environmental Assessment conducted no earlier than 3 months prior to the beginning of the last year of the Term. In addition, no later than the end of the Term, Tenant shall (A) cause all Hazardous Substances previously owned, stored or used by Tenant to be removed from the Premises and disposed of in accordance with all Environmental Law; and (B) remove any Underground Storage Tanks or other containers installed or used by Tenant to store any Hazardous Substances on the Premises, and repair any damage to the Premises caused by such removal.

(b) Upon termination of this Lease and Tenant's satisfactory compliance with all of the requirements of this section, Landlord shall return to Tenant, without interest, the amount deposited in accordance with this section. In the event that Tenant does not cause a Phase I Environmental Assessment to be conducted or does not provide Landlord with a timely report based upon an assessment conducted no earlier than 3 months prior to the beginning of the last year of the Term, Landlord may (but shall

not be required to) cause a Phase I Environmental Assessment to be conducted and may apply the sums previously deposited by Tenant to pay for such assessment. If the assessment costs more than the amount of the deposit, Tenant shall pay to Landlord, upon demand, the difference. If the assessment costs less than the amount of the deposit, Landlord shall, no later than 30 days after payment in full of such costs, return to Tenant a sum equal to the amount by which the deposit exceeds the actual costs of such assessment.

(c) If either Tenant's or Landlord's Phase I Environmental Assessment identifies areas of concern that in Landlord's reasonable judgment indicate that further investigation is required, Tenant, at Tenant's sole cost and expense, shall cause a Phase II Environmental Assessment of the Premises to be conducted. If Tenant does not cause such Phase II Environmental Assessment to be conducted, Landlord may (but shall not be required to) cause a Phase II Environmental Assessment to be conducted and may apply the sums previously deposited by Tenant to pay for such assessment. If the assessment costs more than the amount of the deposit, Tenant shall pay to Landlord, upon demand, the difference. If the assessment costs less than the amount of the deposit, Landlord shall, no later than 30 days after payment in full of such costs, return to Tenant a sum equal to the amount by which the deposit exceeds the actual costs of such assessment. Tenant hereby expressly acknowledges and agrees that Tenant's covenant and obligation to pay all costs and expenses associated with any Phase II Environmental Assessment required under this section, whether commissioned by Tenant or Landlord, shall survive termination of this Lease.

10.11 Clean-up.

10.11.1 **Environmental Report.** If any written report containing results of any Phase I Environmental Assessment ("**Environmental Report**") shall: (i) reveal that the environmental condition of the Premises has materially declined in comparison to the Baseline Assessment; or (ii) Tenant has materially violated any warranty, representation, or covenant of this section; or (iii) recommend the repair, closure, remediation, removal or other clean-up (collectively, the "**Clean-up**") of any Hazardous Substances found on or about the Premises, and if Landlord determines that Tenant is responsible for such Clean-up, then:

(a) Landlord shall provide Tenant with a copy of such Environmental Report and with a written explanation of the reasons why Landlord believes that Tenant is responsible, under the principles of this section for conducting the Clean-up identified in such Environmental Report.

(b) If, within 30 days after receiving a copy of such Environmental Report and such written statement, Tenant fails either (i) to complete the Clean-up, or (ii) with respect to any Clean-up which cannot be completed within such 30-day period, fails to proceed with reasonable diligence to complete such Clean-up as promptly as practicable, then Landlord shall have the right, but not the obligation, to

carry out any Clean-up recommended by the Environmental Report or required by any Government, and to recover all of the costs and expenses of such Clean-up from Tenant as Additional Rent together with Default Interest from the date Landlord incurred such costs and expenses until paid in full.

10.11.2 **Emergency.** If the Environmental Report reveals a situation which, in Landlord's sole discretion, constitutes an emergency, then Landlord shall have the right, but not the obligation, to carry out any Clean-up recommended by the Environmental Report or required by any Government, and to recover all of the costs and expenses of such Clean-up from Tenant as Additional Rent together with interest at the Default Interest from the date Landlord incurred such costs and expenses until paid in full.

10.11.3 **Submission of Report to Government.** To the extent required by Law, Landlord shall be entitled to submit the Environmental Report to any Government.

10.11.4 **Completion of Clean-up Before Surrender or Termination.** Tenant shall complete Clean-up prior to surrender of the Premises and termination of this Lease, and shall fully comply with all Environmental Law and requirements of any Government over the Clean-up, including any requirement to file such assessment, mitigation plan, risk assessment or other information with any such Government prior to such surrender or termination.

10.11.5 **Tenant's Inability to Complete.** Should any such Clean-up for which Tenant is responsible not be completed or should Tenant not receive any Government approvals regarding the Premises or areas adjacent to the Premises required under Environmental Law prior to the expiration or sooner termination of this Lease, including any extensions of this Lease, then (i) Tenant shall deposit with Landlord an amount of money equal to the balance of the estimated costs of the Clean-up; and (ii) if the nature of the Clean-up makes the Premises untenable or unleaseable until the Clean-up is completed, then Tenant shall be liable to Landlord as a holdover tenant, subject to the terms and conditions set forth in this Lease, until the Clean-up has been sufficiently completed to make the Premises suitable for lease to third parties.

10.12 Confidentiality.

10.12.1 **Keeping Information Confidential.** Except if required to do so by Law, or compelled by subpoena or discovery proceedings in any legal action or governmental proceeding, Tenant agrees that Tenant shall not disclose, discuss, disseminate or copy any information, data, findings, communications, conclusions and reports regarding the environmental condition of the Premises, to any Person, including any Government, without the prior written consent of Landlord. Upon completion of any Clean-up of the Premises, Tenant shall deliver and return to Landlord, all information, data, findings, communications, conclusions and reports regarding the environmental condition of the Premises whether provided to Tenant by Landlord or not.

10.12.2 **Scope of Obligation.** Tenant's obligation to maintain the confidentiality of all information, data, findings, communications, conclusions and reports regarding the environmental condition of the Premises, include but are not limited to Tenant's officers, employees, agents, attorneys, environmental consultants and contractors. Tenant's obligation to maintain the confidentiality of all information, data, findings, communications, conclusions and reports regarding the environmental condition of the Premises, shall survive the termination of this Lease.

10.13 **Copies of Environmental Reports.** Tenant shall provide Landlord with a copy of any and all environmental assessments, audits, studies and reports regarding Tenant's past or current activities on the Premises or the environmental condition of the Premises within 30 days of Tenant's receipt of such materials. Tenant shall be obligated to provide Landlord with a copy of such materials without regard to whether they are generated by Tenant or prepared for Tenant, or how Tenant comes into possession of such materials.

10.14 **Survival of Agreements.** The covenants of this section, including the indemnification provision, shall survive the expiration or termination of this Lease, or any termination of Tenant's interest in the Premises.

11. INDEMNIFICATION; LIABILITY OF LANDLORD

11.1 **Obligations.** Tenant shall Indemnify Landlord against any: (a) wrongful act, wrongful omission, or negligence of Tenant (and anyone claiming by or through the Tenant) or its partners, members, directors, officers, or employees; (b) breach or default by Tenant under this Lease; or (c) breach of any representation or warranty Tenant makes in this Lease. Tenant shall also Indemnify Landlord against the following during the Term and so long as Tenant remains in possession after the Expiration Date: (u) any Contest Tenant initiates; (v) any Application made at Tenant's request; (w) use, occupancy, control, management, operation, and possession of the Premises; (x) any Construction and any agreements that Tenant (or anyone claiming through Tenant) makes for any Construction; (y) the condition of the Premises or any street, curb or sidewalk adjoining the Premises, or of any roadways or easements adjoining or appurtenant to the Premises; and (z) any accident, injury or damage whatsoever caused to any person in or on the Premises or upon or under roadways or easements adjoining or appurtenant to the Premises. Tenant shall be required to Indemnify Landlord Group notwithstanding the acts or omissions or negligence of Landlord, but Tenant shall not be required to Indemnify Landlord regarding Landlord's intentional acts or gross negligence. This paragraph does not apply to Environmental Law and Hazardous Substances Discharges, which are covered in Section 10.8.

11.2 **No Liability of Landlord.** During the Term: (a) Tenant is and shall be in exclusive control and possession of the Premises; and (b) Landlord shall not be liable for any injury or damage to any property (of Tenant or any other Person) or to any person occurring on or about the Premises, except to the extent caused by Landlord's intentional

act or gross negligence. Landlord's right to enter and inspect the Premises is intended solely to allow Landlord to ascertain whether Tenant is complying with this Lease and the Power Purchase Agreement and (to the extent this Lease allows) to cure any Default. Such provisions shall not impose upon Landlord any liability to third parties. Nothing in this Lease shall be construed to exculpate, relieve, or Indemnify Landlord from or against any liability of Landlord: (y) to third parties existing at or before the Commencement Date; or (z) arising from Landlord's intentional acts or omissions or gross negligence.

11.3 Indemnification Procedures. Wherever this Lease requires any Indemnitor to Indemnify any Indemnitee, including, without limitation, under Sections 9.2, 10.8, 11.1, 17.5, 18.2, and 26.7 of this Lease:

11.3.1 Prompt Notice. Indemnitee shall promptly Notify Indemnitor of any claim. To the extent, and only to the extent, that Indemnitee fails to give prompt Notice and such failure materially prejudices Indemnitor, Indemnitor shall be relieved of its indemnity obligations for such claim.

11.3.2 Selection of Counsel. Indemnitor shall select counsel reasonably acceptable to Indemnitee. Even though Indemnitor shall defend the action, Indemnitee may, at its option and its own expense, engage separate counsel to advise it regarding the claim and its defense. Such counsel may attend all proceedings and meetings. Indemnitor's counsel shall actively consult with Indemnitee's counsel. Indemnitor and its counsel shall, however, fully control the defense.

11.3.3 Cooperation. Indemnitee shall reasonably cooperate with Indemnitor's defense, provided Indemnitor reimburses Indemnitee's actual reasonable out of pocket expenses (including Legal Costs) of such cooperation.

11.3.4 Settlement. Indemnitor may, with Indemnitee's consent, not to be unreasonably withheld, settle the claim. Indemnitee's consent shall not be required for any settlement by which: (w) Indemnitor procures (by payment, settlement, or otherwise) a release of Indemnitee by which Indemnitee need not make any payment to the claimant; (x) neither Indemnitee nor Indemnitor on behalf of Indemnitee admits liability; (y) the continued effectiveness of this Lease is not jeopardized in any way; and (z) Indemnitee's interest in the Premises is not jeopardized in any way.

11.3.5 Insurance Proceeds. Indemnitor's obligations shall be reduced by net insurance proceeds Indemnitee actually receives for the matter giving rise to indemnification.

12. RIGHT OF CONTEST

12.1 Tenant's Right; Contest Conditions. Notwithstanding anything to the contrary in this Lease, Tenant shall have the right to contest, at its sole cost, by appropriate legal proceedings diligently conducted in good faith, the amount or validity of any Real Estate Taxes or Prohibited Lien; the valuation, assessment, or reassessment

(whether proposed, phased, or final) of the Premises for Real Estate Taxes; the amount of any Real Estate Tax; the validity of any Law or its application to the Premises; the terms or conditions of, or requirements for, any Approval; or the validity or merit of any claim against which this Lease requires Tenant to Indemnify Landlord (any of the foregoing, a “**Contest**”). Tenant may defer payment or performance of the contested obligation pending outcome of the Contest, provided that Tenant causes the following conditions (collectively, the “**Contest Conditions**”) to remain satisfied:

12.1.1 **No Fines.** Such deferral or noncompliance shall not subject Landlord to a material risk of any fine or penalty, except civil penalties for which Tenant has given Landlord a bond, letter of credit, or other security reasonably satisfactory to Landlord (the “**Contest Security**”) in an amount equal to the reasonably estimated amount of such civil penalties.

12.1.2 **No Liability.** Such deferral or noncompliance creates no material risk of a lien, charge, or other liability of any kind against the Fee Estate, unless Tenant has given Landlord Contest Security equal to the reasonably estimated amount of such lien, charge, or other liability.

12.1.3 **No Forfeiture.** Such deferral or noncompliance will not place the Fee Estate in material danger of being forfeited or lost.

12.1.4 **No Cost to Landlord.** Such Contest shall be without cost, liability, or expense to Landlord.

12.1.5 **Diligence.** Tenant shall prosecute such Contest with reasonable diligence and in good faith.

12.1.6 **Payment.** If required for such Contest, Tenant shall have paid the Contested Real Estate Taxes or other matter.

12.1.7 **Collection of Real Estate Taxes.** If such Contest relates to any Real Estate Tax, then such Contest shall suspend its collection from Landlord and the Fee Estate.

12.1.8 **No Tax Deed.** If, at any time, payment of any Real Estate Taxes is necessary to prevent the imminent (i.e., within 30 days) delivery of a tax deed of the Fee Estate for nonpayment, then Tenant shall pay or cause to be paid the sums in sufficient time to prevent delivery of such deed.

12.1.9 **No Event of Default.** No Uncured Event of Default shall exist under this Lease during the pendency of such Contest.

12.1.10 **Security.** If the amount at issue in such Contest (and all other Contests then pending) exceeds an amount equal to \$100,000.00, then Tenant shall,

before proceeding with such Contest, give Landlord Contest Security equal to such excess (less any Contest Security otherwise provided for the same Contest).

12.1.11 **Named Parties.** If Landlord has been named as a party in any action, then Tenant shall cause Landlord to be removed as such party and Tenant substituted in Landlord's place, if permissible under the circumstances.

12.2 **Landlord Obligations and Protections.** Landlord need not join in any Contest unless (a) Tenant has complied with the Contest Conditions; and (b) such Contest must be initiated or prosecuted in Landlord's name. In such case, Landlord shall cooperate, as Tenant reasonably requests, to permit the Contest to be prosecuted in Landlord's name. Landlord shall give Tenant any documents, deliveries, and information in Landlord's control and reasonably necessary for Tenant to prosecute its Contest. Landlord shall otherwise assist Tenant in such Contest as Tenant reasonably requires. Tenant shall pay all reasonable costs and expenses, including Legal Costs, of any Contest. Tenant shall, at Landlord's request, advance (when Landlord incurs them) such reasonable costs and expenses as Landlord incurs or reasonably anticipates incurring, for Tenant's Contest and Landlord's assistance with such Contest.

12.3 **Miscellaneous.** Tenant shall be entitled to any refund of any Real Estate Taxes (and penalties and interest paid by Tenant), to the extent attributable to periods within the Term, whether such refund is made during or after the Term. When Tenant concludes Tenant's Contest of any Real Estate Taxes, Tenant shall pay the amount of such Real Estate Taxes (if any) as has been finally determined in such Contest to be due, to the extent attributable to periods within the Term, and any costs, interest, penalties, or other liabilities in connection with such Real Estate Taxes. Upon final determination of Tenant's Contest of a Law, Tenant shall comply with such final determination. Landlord may contest any matter for which Tenant is entitled to prosecute a Contest, but only if: (a) Landlord Notifies Tenant of Landlord's intention to do so; and (b) Tenant fails to commence such Contest within 15 days after receipt of such Notice.

12.4 **Contest Security.** Landlord shall promptly release any Contest Security to Tenant after the Contest has been resolved and Tenant has performed its obligations, if any, as determined by such resolution.

13. Insurance

13.1 **Tenant to Insure:** Tenant, and anyone acting under its direction or control or on its behalf, shall, at its own expense, acquire and maintain, or cause to be maintained in full effect, at the commencement of this Lease, and continuing throughout the Term, the types and minimum amounts of insurance coverage specified herein.

13.2 Types and Minimum Amounts of Insurance.

13.2.1 **Worker's Compensation and Employers' Liability Insurance:** Workers' Compensation and other similar insurance required by applicable State or U.S.

federal laws. Limits for such coverage shall be not less than the statutory limits for Worker's Compensation and Employers' Liability coverage with minimum limits of:

- \$1,000,000 for Each Accident
- \$1,000,000 Disease-Each Employee
- \$1,000,000 Disease Policy Limit.

13.2.2 Commercial General Liability: Minimum limits of liability shall be a combined single limit for bodily injury and property damage of \$1,000,000 each occurrence, \$2,000,000 general aggregate, \$2,000,000 products and completed operations aggregate; \$1,000,000 Personal and Advertising Injury, \$250,000 Fire Legal Liability, \$5,000 any one person Medical Expense limit Such insurance shall include Premises Operations; Products - Completed Operations; Blanket Contractual Liability; Personal and Advertising Injury; Fire Legal Liability; Employees Named as Additional Insureds; Medical Expense and coverage for independent contractors. If coverage is written on a claims-made basis, the Tenant warrants that any retroactive date applicable to coverage under the policy precedes the Term; and that continuous coverage will be maintained or an extended discovery period will be exercised for a period of three (3) years beginning from the end of the Term. The policy and certificate of insurance shall further contain a provision that the general aggregate limit applies exclusively to the Premises and the operations conducted thereon.

13.2.3 Automobile Liability: Minimum limits of liability shall be a combined single limit for bodily injury and property damage of \$1,000,000 for each occurrence and annual aggregate for any owned, leased and non-owned automobiles.

13.2.4 All Risk Property: This insurance shall provide All Risk Property Coverage (including the perils of wind including named windstorm, earthquake, and flood) against damage to the Premise and the Facility. The amount of coverage shall be purchased on a full replacement cost basis (no coinsurance shall apply) except for earthquake and flood perils which shall be no less than 40% of the replacement value of the Facility up to Twenty Million Dollars (\$20,000,000), if such insurance amounts are appropriate and available on commercially reasonable terms. Such coverage may allow for other reasonable sublimits. Tenant will, at its own expense, at all times during the Term effect and maintain coverage for Business Income with Extra Expense Insurance in an amount sufficient to insure payment of Fixed Rent and Additional Rent and other fixed costs, for a period of not less than twelve (12) months, during any interruption of Tenant's business by reason of the Premises or Tenant's business personal property being damaged by fire or other perils covered under an All Risk Property policy.

13.2.5 Builders and Installation Risk. Tenant will at its own expense effect and maintain during the whole of the Term builder's and installation risk insurance while the Premises or any part thereof are under construction, written on the Builders Risk Completed Value form (nonreporting full coverage), including coverage on equipment, machinery, materials, etc. not yet installed but to become a permanent part of the improvements.

13.2.6 **Umbrella Liability:** Tenant will at its own expense effect and maintain during the whole of the Term Umbrella Liability Insurance providing excess coverage over Commercial General Liability, Employer's Liability, and Automobile Liability Insurance. The Umbrella Liability policy shall be written on an "occurrence" form with a limit of liability of not less than \$20,000,000 per policy year and a self-insured retention and/or deductible no greater than \$25,000.00.

13.3 **Form of Policies:**

13.3.1 **Form and Substance:** All insurance required to be furnished by Tenant hereunder shall be pursuant to policies in form and substance satisfactory to Landlord, and issued by a company authorized by law to issue such insurance in the State of Hawaii on an admitted or non-admitted basis, and with an A.M. Best Financial Strength Rating of "A-" or better, and an A.M. Best Financial Size Category of "VII" or higher. In the event that such rating system is altered or eliminated, then the insurer shall have a rating comparable to such A-, VII from a comparable rating service that has been adopted for standard use in the insurance industry.

13.3.2 **Required Provision:** All insurance policies shall:

(a) **Additional Insured:** The insurance policies specified herein shall name Landlord, together with its affiliates, including but not limited to Lāna‘i Island Holdings, LLC, and their respective members, officers, employees, agents, successors and assigns ("Landlord Group"), as an additional insured, as its interests may appear, with respect to any and all third party bodily injury and/or property damage claims, including completed operations, arising from Tenant's performance of this Lease. All Risk Property Insurance shall include Landlord Group as loss payee, as its interest may appear. Coverage must be primary in respect to the additional insured. Any other insurance carried by the Landlord will be excess only and not contribute with this insurance.

(b) **Severability of Interest:** Apply separately to each insured against whom claim is made or suit is brought.

(c) **Waiver of Subrogation:** Tenant shall cause its insurers to waive all rights or subrogation which Tenant or its insurers may have against Landlord Group.

(d) The policies and certificate of insurance shall also specifically provide the following or comparable language: "**It is further agreed that such insurance is afforded by this policy for the benefit of the Additional Insured shall be primary insurance, and any other insurance maintained by the Additional Insured shall be excess and non-contributory.**"

13.3.3 **All Insurance:** All insurance shall:

APPENDIX F ATTACHMENT 2

(a) **No Premiums:** Not require Landlord to pay any premiums.

(b) **No Partnership:** The inclusion of Landlord Group as Additional Insured is not intended to, and shall not make them or any of them, a partner or joint venture with Tenant in the operation of Tenant's Facility in, on, over, under or about the Premises.

(c) **Deductibles:** Any insurance required hereunder may provide for deductibles or self-insured retentions which are reasonable and prudent in relationship to the soundness of Tenant's financial condition at the sole discretion of Landlord. Any deductibles or self-insured retention in excess of \$25,000 shall be disclosed to Landlord. Any deductible shall be the responsibility of Tenant.

13.3.4 **Certificate of Insurance:** Evidence of insurance for the coverage specified herein shall be provided to Landlord before the commencement of the Lease. Within 30 Days of any change of any policy and upon renewal of any policy, Tenant shall provide certificates of insurance to Landlord. During the Term, Tenant, upon Landlord's reasonable request, shall make available to Landlord for its inspection at Tenant's designated location, certified copies of the insurance policies described herein. Receipt of any evidence of insurance showing less coverage than requested is not a waiver of Tenant's obligations to fulfill the requirements.

13.3.5 **Notification:** In the event Tenant receives notice of cancellation or non-renewal of any insurance in accordance with policy provisions, Tenant shall immediately provide verbal and written notice to Landlord. In the event Tenant chooses to voluntarily cancel, non-renew, or reduce the scope of coverage or limits of liability, Tenant shall notify Landlord in writing at least thirty (30) days prior to such cancellation, non-renewal, or reduction in scope of coverage or limits of liability. In any event, the cancellation or non-renewal of any insurance shall not be construed as a limitation of any kind on Tenant's obligations to indemnify, defend, insure, and hold harmless, as may be found anywhere in this or any other document.

13.4 **Annual Review by Landlord:** The coverage limits shall be reviewed annually by Landlord and if, in Landlord's discretion, Landlord determines that the coverage limits should be increased, Landlord shall so notify Tenant. Tenant shall, within thirty (30) Days of notice from Landlord, increase the coverage as directed in such notice and the costs of such increased coverage limits shall be borne by Tenant.

13.5 **No Limitation:** Tenant's procurement and maintenance of insurance, or the delivery of Certificates of Insurance or other written evidence of insurance in form and substance acceptable to Landlord shall not be construed as a limitation of any kind on Tenant's obligations to indemnify, defend, insure, and hold harmless, as may be found anywhere in this or any other document.

No Representation of Coverage Adequacy: By requiring insurance herein, Landlord does not represent that coverage and limits will necessarily be adequate to protect Tenant,

and such coverage and limits shall not be deemed as a limitation on Tenant's liability under the indemnities granted to Tenant in this Lease.

Loss or Damage to Improvements. In every case of loss or damage to any Improvements on the Land, Tenant shall with all reasonable speed, rebuild, repair or otherwise reinstate the Improvements in accordance with the original plans or such modified plans conforming to laws and regulations then in effect as approved in writing by Landlord. Approval by Landlord shall not be unreasonably withheld, delayed or conditioned. All proceeds of such insurance (excluding the proceeds of any rental value or use and occupancy insurance of Tenant), whether held by Tenant or by Insurance Trustee, shall be used for such purpose, and Lessee will make up any deficiency in the insurance proceeds from its own funds.

14. LOSSES AND LOSS PROCEEDS

14.1 **Notice.** If either party becomes aware of any Casualty or any actual, threatened, or contemplated Condemnation, then such party shall promptly Notify the other.

14.2 **Casualty.** If a Casualty occurs which is not a Substantial Casualty, then: (a) no Rent shall abate; (b) this Lease shall not terminate or be impaired; and (c) Tenant shall Restore with reasonable promptness regardless of cost. If the Casualty is determined to be a Substantial Casualty, then Tenant may, by Notice to Landlord, given within 10 days after such determination, terminate this Lease effective 30 days after such Notice, provided that Tenant assigns to Landlord all proceeds from applicable property insurance policies (and rights thereto) arising from the Casualty.

14.3 **Substantial Condemnation.** If a Substantial Condemnation occurs, then this Lease (except as it relates to allocation of the Condemnation Award) shall terminate on the Condemnation Effective Date. Rent shall be apportioned accordingly. The Condemnation Award shall be allocated as follows:

14.3.1 **Prepayment Premium.** To Leasehold Mortgagee, to the extent that both (1) because of such Condemnation, any Leasehold Mortgagee imposes any fee or charge that such Leasehold Mortgagee could not have collected but for the Condemnation and the related prepayment of such Leasehold Mortgagee's loan; and (2) the Condemnation Award was directly or indirectly increased by such fee or charge.

14.3.2 **Costs and Expenses.** To reimburse Landlord and Tenant (subject to the rights of Leasehold Mortgagees) for their actual costs and expenses, including Legal Costs, incurred in the Substantial Condemnation and determining and collecting the Condemnation Award.

14.3.3 **Tenant's Claim.** Tenant shall, subject to the rights of Leasehold Mortgagees, receive such portion of the Condemnation Award as shall equal the lesser of

(a) all sums secured by all Leasehold Mortgages; and (b) the Market Value of the Facility at the Condemnation Effective Date.

14.3.4 **Landlord's Claim.** Landlord shall, subject to the rights of Fee Mortgagees, receive such portion of the Condemnation Award as shall equal the Market Value of the Land, at the Condemnation Effective Date.

14.3.5 **Landlord's Residual Claim.** Landlord shall, subject to the rights of Fee Mortgagees, receive the entire remaining Condemnation Award.

14.4 **Insubstantial Condemnation.** If an Insubstantial Condemnation occurs after the Commencement Date, then any Condemnation Award(s) shall be paid to Depository and applied first toward Restoration, in the same manner as Restoration after Casualty. Whether or not the Condemnation Award is adequate, Tenant shall, at its expense, Restore in compliance with this Lease. After Tenant has completed and fully paid for Restoration, any remaining Condemnation Award shall be distributed to Landlord and Tenant as if it arose from a Substantial Condemnation that affected only the part of the Premises taken, with an equitable allocation of all elements taken into account in determining such distribution.

14.5 **Temporary Condemnation.** If a Temporary Condemnation occurs (a) no Rent shall abate; (b) this Lease shall not terminate or be impaired; and (c) Tenant shall receive any Condemnation Award (to the extent for periods within the Term), without affecting Tenant's obligations in any way.

14.6 **Use of Loss Proceeds.**

14.6.1 **Assignment to Depository.** All Loss Proceeds shall be paid to Depository, to be disbursed by Depository, subject to the terms of the Senior Leasehold Mortgage and this Lease. If Landlord receives any Loss Proceeds, Landlord shall promptly remit them to Depository.

14.6.2 **Immaterial Loss.** If a Loss is an Immaterial Loss, then (subject to the terms of the Leasehold Mortgage on disbursement of Loss Proceeds to Restore) the Depository shall release all Loss Proceeds to Tenant, to be applied first to Restoration.

14.6.3 **Material Loss.** If a Loss is not an Immaterial Loss, then Depository shall retain the Loss Proceeds and pay them over to Tenant from time to time, upon the following terms, for Restoration. Depository shall first reimburse Landlord and Tenant from such Loss Proceeds for their actual, necessary, and proper costs and expenses in collecting such Loss Proceeds. Depository shall release Loss Proceeds to Tenant from time to time as Restoration progresses in accordance with the procedures required by the Leasehold Mortgagee. If no Leasehold Mortgage exists, then Depository shall disburse the Loss Proceeds from time to time pursuant to normal and customary disbursement procedures consistent with this Lease, but excluding any requirement for a guaranty, bond, security, or other credit enhancement or credit support measures.

14.6.4 **Loss Proceeds in Trust.** Until Tenant has completed and paid for Restoration, Tenant shall hold all Loss Proceeds in trust to be used first to Restore and for no other purpose. If any Prohibited Lien is filed against the Premises, Tenant shall not be entitled to receive any further installment of Loss Proceeds until Tenant has satisfied, bonded, or otherwise discharged such Prohibited Lien when and as this Lease requires.

14.6.5 **Remaining Loss Proceeds.** When Tenant has completed and paid for Restoration, Depository shall release to Tenant, and Tenant may retain (subject to rights of Leasehold Mortgages) any remaining Loss Proceeds.

14.6.6 **Insufficient Restoration Funds.** If Restoration Funds are insufficient to Restore, then Tenant shall nevertheless Restore at its expense. Depository shall not release any Loss Proceeds until and unless Tenant has expended on such Restoration an amount equal to any such insufficiency.

14.7 **Disputes.**

14.7.1 **Good Faith Negotiations.** Except as otherwise expressly set forth in this Lease, before submitting any dispute about a Loss (including its characterization), Restoration, timing of Restoration, Loss Proceeds, Restoration Funds, or the use of such proceeds or funds to dispute resolution or litigation, the presidents, vice presidents, or authorized delegates from both Landlord and Tenant having full authority to settle the dispute shall personally meet in Hawaii and attempt in good faith to resolve the dispute (“**Management Meeting**”). Landlord and Tenant shall endeavor to hold the Management Meeting within thirty (30) days after the date of a request for a Management Meeting. Landlord and Tenant shall not file a complaint or initiate other formal dispute resolution proceedings until ninety (90) days after the date of a request for a Management Meeting, except as might be necessary to preserve a right or claim that would expire during the ninety-day period.

15. **LANDLORD’S TRANSFERS**

15.1 **Landlord’s Right to Convey.** Landlord may Transfer the Fee Estate from time to time. Landlord will promptly Notify Tenant of a Transfer.

15.2 **Release of Landlord.** Upon any Transfer of the entire Fee Estate in compliance with this Lease, the grantor shall be automatically freed and relieved from all liability (excluding liability previously accrued) for performance of any covenants or obligations to be performed by Landlord after the Transfer, provided that such successor Landlord assumes Landlord’s past, present, and future obligations under this Lease. This Lease shall bind Landlord only while Landlord owns the Fee Estate, except as to any liabilities and obligations accrued before the date of Transfer of the Fee Estate.

16. TENANT'S TRANSFERS

16.1 **Tenant's Limited Right.** Tenant may only Transfer this Lease to an assignee of all of the rights and obligations of the Seller under the Power Purchase Agreement and only after obtaining Landlord's written consent which may be withheld in Landlord's sole discretion. Tenant may not Transfer this Lease to any other Person, and any such Transfer shall be void. Any permitted assignee of Tenant shall assume all obligations and liabilities of Tenant under this Lease. Tenant shall pay all transfer and other taxes payable on account of any Transfer by Tenant or any holder of any Equity Interest in Tenant. Tenant shall promptly Notify Landlord of any Transfer. No Transfer shall affect any obligations of Tenant or rights of Landlord under this Lease.

16.2 **Subleases.** Tenant shall not enter into or Modify any Sublease, without Landlord's prior written consent which may be withheld in Landlord's sole discretion. No Sublease shall affect any obligations of Tenant or rights of Landlord under this Lease, all of which shall continue in full force and effect notwithstanding any Sublease. Any Sublease shall be subject in all respects to the terms and conditions of this Lease except that, unless terminated sooner under the terms thereof, any such Sublease shall expire no later than one hour before the Expiration Date. The fact that any Subtenant causes any Default shall not relieve Tenant of Tenant's obligation to cure it. Tenant shall take all steps reasonable and necessary to prevent any such Default.

16.3 **Conditions to Effectiveness of Certain Transactions.** No assignment of this Lease or Sublease shall be effective or have any validity unless and until such assignment or Sublease otherwise complies with this Lease and Landlord has received: (a) in the case of an assignment, an executed counterpart of the assignment and an assumption of this Lease by the assignee, in recordable form, effective as of the date of assignment; (b) in the case of a Sublease, a copy of the executed Sublease complying with this Lease; and (c) Notice of the assignee or Subtenant.

17. LEASEHOLD MORTGAGE

17.1 **Leasehold Mortgage.** Provided that any Monetary Default or material Nonmonetary Default has been, or simultaneously is, cured, Tenant may grant a Leasehold Mortgage to a Financing Party under the Power Purchase Agreement in connection with a permitted financing under the Power Purchase Agreement.

17.2 **Leasehold Mortgagee's Remedies.** Without Landlord's consent, at any time (a) any Leasehold Mortgagee may initiate and complete any Foreclosure Event and exercise any other rights and remedies against Tenant and the Leasehold Estate (but not the Fee Estate) under its Leasehold Mortgage; and (b) any transferee through a Foreclosure Event, and its successors and assigns, may assign this Lease to a Person who simultaneously assumes all of the rights and obligations of the Seller under the Power Purchase Agreement.

17.3 Lease Impairments. Any Lease Impairment made without Leasehold Mortgagee's consent shall (at Leasehold Mortgagee's option) be null, void, and of no force or effect, and not bind Tenant, Leasehold Mortgagee, or New Tenant.

17.4 Notices. If any Default occurs for which Landlord intends to exercise any remedy, Landlord shall promptly give Leasehold Mortgagee a Notice of Default.

17.5 Right to Cure; Indemnity. Any Leasehold Mortgagee shall have the right, but not the obligation, to perform any obligation of Tenant under this Lease and to cure any Default under the terms and conditions provided in this Section 17.5. Landlord shall accept performance by or at the instigation of a Leasehold Mortgagee in fulfillment of Tenant's obligations, for the account of Tenant and with the same force and effect as if performed by Tenant, provided that such performance is rendered within the cure period that applies to a Leasehold Mortgagee under this Lease under this Section 17.5.

17.5.1 Opportunity to Cure. Landlord shall accept Leasehold Mortgagee's cure of any Default at any time until 90 days after Leasehold Mortgagee has received the Notice of Default for that Default, provided Landlord has received a Notice of Intent to Cure from Leasehold Mortgagee on or by 30 days after Leasehold Mortgagee's receipt of the Notice of Default. If Landlord does not receive a timely Notice of Intent to Cure under the preceding sentence, Landlord may terminate this Lease under Section 19.2.1 or exercise any other Remedies as may be available at law or in equity or under any terms of this Lease. If Landlord receives a timely Notice of Intent to Cure and Leasehold Mortgagee cannot reasonably cure any Nonmonetary Default within 90 days after receiving the Notice of Default for that Default, Leasehold Mortgagee shall have such further time as it reasonably needs so long as it proceeds with the diligence expected of an experienced independent power producer willing and able to exert commercially reasonable efforts to achieve such cure, but in any event no longer than 180 days. If Leasehold Mortgagee cannot reasonably cure a Default without possession, or if any Tenant-Specific Default(s) occur(s), Leasehold Mortgagee shall be entitled to such additional time as it reasonably needs to consummate a Foreclosure Event and obtain possession, provided Leasehold Mortgagee timely exercises its cure rights for all other Defaults, and completes the Foreclosure Event within 365 days. If Leasehold Mortgagee consummates a Foreclosure Event, Landlord shall waive all Tenant-Specific Defaults, provided that all other Defaults are cured.

17.5.2 Indemnity for Cure Activities. Notwithstanding anything to the contrary in this Lease, if any Leasehold Mortgagee (or a representative of Leasehold Mortgagee) desires to enter the Premises to cure any Default, Leasehold mortgagee may enter the Premises to seek to cure a Default. This right or its exercise shall not be deemed to give Leasehold Mortgagee possession. By entering the Premises, such Leasehold Mortgagee shall be deemed to have agreed to Indemnify Landlord in the same manner as this Lease requires Tenant to Indemnify Landlord, but solely regarding direct damages that Landlord suffers as a result of any acts or omissions of such Leasehold Mortgagee or its representative on or in the Premises in seeking to cure any such Default.

17.6 Cure Rights Implementation. Whenever Leasehold Mortgagee's time to cure a Default or consummate a Foreclosure Event has not expired, provided that Leasehold Mortgagee has timely provided Landlord with a Notice of Intent to Cure pursuant to Section 17.5.1 above, Landlord shall not terminate this Lease, accelerate any Rent, or otherwise interfere with Tenant's or Leasehold Mortgagee's possession and quiet enjoyment of the Leasehold Estate.

17.7 New Lease. If this Lease terminates for any reason (except with Leasehold Mortgagee's consent or because of a Total Loss), even if Leasehold Mortgagee failed to timely exercise its cure rights for a Default, Landlord shall promptly give Leasehold Mortgagee a Lease Termination Notice. By giving notice to Landlord on or before the day that is 30 days after Leasehold Mortgagee receives Landlord's Lease Termination Notice, Leasehold Mortgagee may require Landlord to promptly enter into a New Lease with New Tenant. Landlord need not do so, however, unless New Tenant has, consistent with the Lease Termination Notice: (a) cured all reasonably curable Defaults (except Tenant-Specific Defaults); (b) reimbursed Landlord's reasonable costs and expenses (including reasonable attorneys' fees and expenses) to terminate this Lease, recover the Premises, and enter into the New Lease; and (c) assumed the Power Purchase Agreement, or with Landlord's consent, arranged for the assumption of the Power Purchase Agreement by the New Tenant.

17.8 New Lease Implementation. If Leasehold Mortgagee timely requests a New Lease in conformity with this Lease, then from the date this Lease terminates until the parties execute and deliver a New Lease, Landlord shall not: (a) operate the Premises in an unreasonable manner; (b) terminate Sublease(s) except for the Subtenant's default; or (c) lease any Premises except to New Tenant. When the parties sign a New Lease, Landlord shall transfer to New Tenant and New Tenant shall accept all Subleases (including any security deposits Landlord held), service contracts, and Premises operations.

17.9 Certain Proceedings. If Landlord or Tenant initiates any mediation, litigation, or other dispute resolution proceeding affecting this Lease, then the parties shall simultaneously Notify Leasehold Mortgagee. Leasehold Mortgagee may participate in such proceedings on Tenant's behalf, or exercise any or all of Tenant's rights in such proceedings, in each case (at Leasehold Mortgagee's option) to the exclusion of Tenant.

17.10 No Merger. If the Leasehold Estate and the Fee Estate are ever commonly held, they shall remain separate and distinct estates (and not merge) without Leasehold Mortgagee's and Fee Mortgagee's consent.

17.11 Multiple Leasehold Mortgages. If at any time multiple Leasehold Mortgagees exist: (a) any consent by or notice to Leasehold Mortgagee refers to all Leasehold Mortgagees; (b) except under clause (a), the most senior Leasehold Mortgagee may exercise all rights of Leasehold Mortgagee(s), to the exclusion of junior Leasehold Mortgagee(s); (c) to the extent that the most senior Leasehold Mortgagee declines to do

so, any other Leasehold Mortgagee may exercise those rights, in order of priority; and (d) if Leasehold Mortgagees do not agree on priorities, a written determination of priority issued by a title insurance company licensed in the State (or such insurer's designated authorized title agent, e.g. Title Guaranty of Hawaii, Inc.), selected by Landlord in its sole discretion, shall govern.

17.12 Further Assurances. Upon request from Tenant or any Leasehold Mortgagee (prospective or current), Landlord shall promptly, under documentation reasonably satisfactory to the requesting party and the Landlord: (a) agree directly with Leasehold Mortgagee that it may exercise against Landlord all Leasehold Mortgagee's rights in this Lease so long as Leasehold Mortgagee complies with all terms and conditions of this Lease in connection with the exercise of such remedies; and (b) certify (subject to any then-existing exception(s) reasonably specified) that this Lease is in full force and effect, that no Lease Impairment has occurred, that to Landlord's knowledge no Default exists, the date through which Rent has been paid, and other similar matters as reasonably requested and mutually agreeable between Landlord and such Leasehold Mortgagee.

18. QUIET ENJOYMENT; TITLE TO CERTAIN PREMISES; CERTAIN AGREEMENTS

18.1 Quiet Enjoyment. So long as this Lease has not been terminated, Landlord covenants that Tenant shall and may peaceably and quietly have, hold, and enjoy the Premises for the Term, subject to the terms of this Lease, without molestation, hindrance, or disturbance by or from Landlord or anyone claiming by or through Landlord or having title to the Premises paramount to Landlord, and free of any encumbrance created or suffered by Landlord, except Permitted Exceptions.

18.2 Access and Inspection. Notwithstanding anything to the contrary in this Lease, Landlord and its agents, representatives, and designees may enter the Premises upon reasonable Notice to: (a) ascertain whether Tenant is complying with this Lease and the Power Purchase Agreement; (b) cure Tenant's Defaults; (c) inspect the Premises and any Construction; (d) perform such tests, borings, and other analyses as Landlord determines may be necessary or appropriate relating to (non)compliance with any Law or possible Hazardous Substances Discharge; or (e) show the Premises to a prospective Transferee or Fee Mortgagee. In entering the Premises, Landlord and its designees shall not unreasonably interfere with operations on the Premises and shall comply with Tenant's reasonable instructions. Landlord shall Indemnify Tenant against any claims arising from Landlord's entry upon the Premises (except upon termination of this Lease or an Event of Default).

18.3 Title. Notwithstanding anything to the contrary in this Lease, all Improvements located in, on, or at the Premises or otherwise constituting part of the Premises shall during the Term be owned by, and belong to, Tenant. All benefits and

burdens of ownership of the foregoing, including title, depreciation, tax credits, and all other tax items, shall be and remain in Tenant during the Term.

19. EVENTS OF DEFAULT; REMEDIES

19.1 **Definition of “Event of Default.”** An “Event of Default” means the occurrence of any one or more of the following:

19.1.1 **Monetary Default.** If a Monetary Default occurs and continues for 30 days after Notice from Landlord, specifying in reasonable detail the amount of money not paid and the nature and calculation of each such payment.

19.1.2 **Prohibited Liens.** If Tenant fails to comply with any obligation regarding Prohibited Liens and does not remedy such failure within 15 days after Notice from Landlord.

19.1.3 **Power Purchase Agreement.** If a Default by Tenant occurs under the Power Purchase Agreement, which continues beyond any cure or grace period allowed under the Power Purchase Agreement.

19.1.4 **Bankruptcy or Insolvency.** If Tenant ceases to do business as a going concern, ceases to pay its debts as they become due or admits in writing that it is unable to pay its debts as they become due, or becomes subject to any Bankruptcy Proceeding (except an involuntary Bankruptcy Proceeding dismissed within 180 days after commencement), or a custodian or trustee is appointed to take possession of, or an attachment, execution or other judicial seizure is made with respect to, substantially all of Tenant’s assets or Tenant’s interest in this Lease (unless such appointment, attachment, execution, or other seizure was involuntary and is contested with diligence and continuity and vacated and discharged within 180 days).

19.1.5 **Nonmonetary Default.** If any other Nonmonetary Default occurs and Tenant does not cure it within 30 days after Notice from Landlord describing it in reasonable detail, or, in the case of a Nonmonetary Default that cannot with due diligence be cured within 30 days from such Notice, if Tenant shall not (a) within 30 days from Landlord’s Notice advise Landlord of Tenant’s intention to take all reasonable steps to cure such Nonmonetary Default; (b) duly commence such cure within such period, and then diligently prosecute such cure to completion; and (c) complete such cure within a reasonable time under the circumstances, but in any event within 90 days from the receipt of such Notice.

19.2 **Remedies.** If an Event of Default occurs, then Landlord shall, at Landlord’s option, have any or all of the following remedies, all cumulative (so exercise of one remedy shall not preclude exercise of another remedy), in addition to such other remedies as may be available at law or in equity or under any other terms of this Lease. Landlord’s remedies include:

19.2.1 **Termination of Tenant's Rights.** Landlord may terminate Tenant's right to possess the Premises by any lawful means, in which case this Lease and the Term shall terminate, such date of termination shall be the Expiration Date, and Tenant shall immediately surrender possession to Landlord.

19.2.2 **Taking Possession.** Landlord may re-enter and take possession of the Premises with process of law, whether by summary proceedings or otherwise, and remove Tenant, with or without having terminated this Lease, and without thereby being liable for damages or guilty of trespass. This is intended to constitute an express right of re-entry by Landlord. Except as expressly provided in this Lease or prohibited by Law, Tenant, for and on behalf of itself and all persons claiming by, through or under Tenant, expressly waives any right to service of notice of intention to re-enter provided in any Law and any and all right of redemption provided by any Law, or re-entry or repossession or to restore the operation of this Lease if Tenant is dispossessed by a judgment or by writ of any court or judge or in case of re-entry or repossession by Landlord or any expiration or termination of this Lease. No re-entry by Landlord, whether had or taken under summary proceedings or otherwise, shall absolve or discharge Tenant from liability under this Lease. The terms "enter," "re-enter," "entry," and "re-entry," as used in this Lease, are not restricted to their technical legal meanings.

19.2.3 **Suits Before Expiration Date.** Landlord may sue for damages or to recover Rent from time to time at Landlord's election.

19.2.4 **Receipt of Moneys.** No receipt of money by Landlord from Tenant after termination of this Lease, or after the giving of any notice of termination of this Lease, shall reinstate, continue, or extend this Lease or affect any notice theretofore given to Tenant, or waive Landlord's right to enforce payment of any Rent payable or later falling due, or Landlord's right to recover possession by proper remedy, except as this Lease expressly states otherwise, it being agreed that after service of notice to terminate this Lease or the commencement of suit or summary proceedings, or after final order or judgment for possession, Landlord may demand, receive, and collect any moneys due or thereafter falling due without in any manner affecting such notice, proceeding, order, suit or judgment, all such moneys collected being deemed payments on account of use and occupation or, at Landlord's election, on account of Tenant's liability.

19.2.5 **No Waiver.** No failure by Landlord to insist upon strict performance of any covenant, agreement, term, or condition of this Lease or to exercise any right or remedy upon a Default, and no acceptance of full or partial Rent during continuance of any such Default, shall waive any such Default or such covenant, agreement, term, or condition. No covenant, agreement, term, or condition of this Lease to be performed or complied with by Tenant, and no Default, shall be Modified except by a written instrument executed by Landlord. No waiver of any Default shall Modify this Lease. Each and every covenant, agreement, term, and condition of this Lease shall

continue in full force and effect with respect to any other then-existing or subsequent Default of such covenant, agreement, term or condition of this Lease.

19.2.6 **Security Devices.** Landlord may change the locks and other security devices providing admittance to the Premises and Tenant agrees that any such exercise by Landlord shall not be deemed to be unreasonable or a breach of the peace.

19.2.7 **Conditional Limitation.** Landlord may serve upon Tenant a written 30-day notice of cancellation and termination of this Lease. Upon the expiration of such 30-day period, this Lease and the Term shall automatically and without any action by anyone terminate, expire, and come to an end, by the mere lapse of time, as fully and completely as if the expiration of such 30-day period were the Expiration Date. The passage of such 30-day period constitutes the limit beyond which Tenant's tenancy no longer exists. Tenant shall then quit and surrender the Premises to Landlord but remain liable as this Lease provides. It is a conditional limitation of this Lease that the Term shall terminate and expire as set forth in this paragraph. This paragraph is intended to establish a conditional limitation and not a condition subsequent. Nothing in this paragraph shall limit Landlord's right to commence and prosecute a summary possession proceeding under Chapter 666 of the Hawaii Revised Statutes.

19.2.8 **Damages.** Landlord may recover from Tenant all damages Landlord incurs by reason of Tenant's Default, including reasonable costs of recovering possession, reletting the Premises, and any and all other damages legally recoverable by Landlord, and reimbursement of Landlord's reasonable out of pocket costs, including Legal Costs and bank fees for dishonored checks. Such damages shall include, at Landlord's election, either (a) the present value, calculated at a discount rate equal to the then-current Prime Rate of the excess of the total Fixed Rent under this Lease over the fair market rental value of the Premises for the balance of the Term; or (b) the Rent payable to Landlord provided for in this Lease, when and as due and payable under this Lease, less (in the case of this clause (b) only) Landlord's actual proceeds of reletting less Landlord's actual reasonable costs of reletting. Landlord may recover such damages at any time after Tenant's default, including after expiration of the Term. Notwithstanding any Law to the contrary, (x) Landlord need not commence separate actions to enforce Tenant's obligations for each month's Rent not paid, or each month's accrual of damages for Tenant's Default, but may bring and prosecute a single combined action for all such Rent and damages; and (y) Landlord may not recover any consequential damages for Tenant's Default.

19.2.9 **Injunction of Breaches.** Whether or not an Event of Default has occurred, Landlord may obtain a court order enjoining Tenant from continuing any Default or from committing any threatened Default. Tenant specifically and expressly acknowledges that damages would not constitute an adequate remedy for any Nonmonetary Default.

19.2.10 **Continue Lease.** Landlord may at Landlord's option maintain Tenant's right to possession. In that case, this Lease shall continue and Landlord may continue to enforce it, including the right to collect Rent when due and any remedies for nonpayment.

19.2.11 **Restoration Funds.** Upon any termination of this Lease, to the extent that Landlord or Depository then holds any Restoration Funds, they shall be applied solely as Landlord directs, including as a payment toward any sums then payable to Landlord.

19.3 **Proceeds of Reletting.** Landlord shall apply any proceeds of any reletting as follows, without duplication, but including Default Interest on all such sums:

19.3.1 **Landlord's Costs.** *First*, to pay to itself the cost and expense of terminating this Lease, re-entering, retaking, repossessing, repairing, performing any Construction, and the cost and expense of removing all persons and property therefrom, including in such costs reasonable and customary brokerage commissions and Legal Costs;

19.3.2 **Preparation for Reletting.** *Second*, to pay to itself the cost and expense reasonably sustained in securing any new tenants and other occupants, including in such costs all brokerage commissions, Legal Costs, and any other reasonable costs of preparing the Premises for reletting;

19.3.3 **Costs of Maintenance and Operation.** *Third*, to the extent that Landlord shall maintain and operate the Premises, to pay to itself the reasonable cost and expense of doing so; and

19.3.4 **Residue.** *Fourth*, to pay to itself any balance remaining on account of Tenant's liability to Landlord.

19.4 **Tenant's Late Payments; Late Charges.** If Tenant fails to make any payment to Landlord required under this Lease within 10 days after such payment is first due and payable, then in addition to any other remedies of Landlord, and without reducing or adversely affecting any of Landlord's other rights and remedies, Tenant shall pay Landlord within 10 days after demand Default Interest on such late payment, beginning on the date such payment was first due and payable and continuing until the date when Tenant actually makes such payment. In addition, and without limiting any other rights or remedies of Landlord, Tenant shall pay Landlord, as Additional Rent, an administrative charge equal to 3% of any payment that Tenant fails to pay within 10 days after such payment is first due and payable. Such administrative charge is intended to compensate Landlord for the inconvenience and staff time incurred by Landlord to handle the late or missed payment, shall not be deemed a penalty or compensation for use of funds, and shall not be credited against any other obligations of Tenant under this Lease.

19.5 Landlord's Right to Cure. If Tenant at any time fails to make any payment or take any action this Lease requires, then Landlord, after 10 Business Days' Notice to Tenant, or in an emergency with such notice (if any) as is reasonably practicable under the circumstances, and without waiving or releasing Tenant from any obligation or Default and without waiving Landlord's right to take such action as this Lease may permit as a result of such Default, may (but need not) make such payment or take such action. Tenant shall reimburse Landlord, as Additional Rent, for an amount equal to (a) all reasonable sums paid, and reasonable costs and expenses (including Legal Costs) incurred, by Landlord in exercising its cure rights under this paragraph; and (b) Default Interest on (a).

19.6 Holding Over. If for any reason or no reason Tenant remains in the Premises after the Expiration Date, or fails to complete a Clean-up under Section 10.11.5, or fails to remove Improvements required to be removed after the Removal Period under Section 20.2, then Landlord will suffer injury that is substantial, difficult, or impossible to measure accurately. Therefore, if Tenant remains in the Premises after the Expiration Date, or fails to complete a Clean-up under Section 10.11.5, or fails to remove Improvements required to be removed after the Removal Period under Section 20.2, for any reason or no reason, then in addition to any other rights or remedies of Landlord, Tenant shall pay to Landlord, as liquidated damages and not as a penalty, for each month (prorated daily for partial months) during which Tenant holds over after the Expiration Date, a sum equal to: twenty percent (20%) of the Land Value, together with all Additional Rent owed for such period.

19.7 Waivers. Landlord and Tenant irrevocably waive all rights to trial by jury in any action, proceeding, counterclaim, or other litigation arising out of or relating to this Lease, the relationship of Landlord and Tenant regarding the Premises, enforcement of this Lease, Tenant's use or occupancy of the Premises, any claim of injury or damage arising between Landlord and Tenant, or any actions of Landlord in connection with or relating to the enforcement of this Lease. Tenant waives any right of redemption provided for by Law. Tenant waives any right to interpose any counterclaim in any action by Landlord to enforce this Lease or Landlord's rights and remedies under this Lease.

19.8 Accord and Satisfaction; Partial Payments. No payment by Tenant or receipt by Landlord of a lesser amount than the amount owed under this Lease shall be deemed to be other than a partial payment on account by Tenant. Any endorsement or statement on any check or letter accompanying any check or payment of Rent shall not be deemed an accord or satisfaction. Landlord may accept any such check or payment without prejudice to Landlord's right to recover the balance of such Rent or pursue any other remedy.

19.9 Miscellaneous. Landlord and Tenant further agree as follows with respect to any Defaults and Landlord's rights and remedies.

19.9.1 **Survival.** No termination of this Lease and no taking possession of or reletting the Premises shall relieve Tenant of its liabilities and obligations hereunder, all of which shall survive such expiration, termination, repossession, or reletting, but subject to any limitations on personal liability or recourse in this Lease.

19.9.2 **Multiple Suits.** Landlord may sue to recover damages, or sum(s) equal to any installment(s) of Rent payable by Tenant, from time to time at Landlord's election. Nothing in this Lease requires Landlord to await the date when this Lease or the Term would have expired absent an Event of Default and a resulting termination of this Lease.

19.9.3 **Receipt of Monies.** Unless such payment shall fully cure all Monetary Defaults, no receipt of moneys by Landlord from Tenant after the giving of a termination notice or a notice to obtain possession, or after the retaking of possession by Landlord as aforesaid, shall reinstate, continue, or extend the Term or affect any notice previously given to Tenant, waive Landlord's right to enforcement of Rent payable by Tenant or thereafter falling due, or waive Landlord's right to recover possession of the Premises. After the service of any such notice, or commencement of any suit or summary proceedings, or after a final order or judgment for possession of the Premises, Landlord may demand, receive, and collect any moneys due or thereafter falling due without in any manner affecting such notice, proceeding, order, suit, or judgment, unless such payments fully cure all Monetary Defaults. Any sums so collected (without thereby curing all Monetary Defaults) shall instead be deemed payments on account of use and occupation of the Premises or, at Landlord's election, to have been made on account of Tenant's liability under this Lease.

19.9.4 **No Double Recovery.** In no event shall Landlord be entitled, directly or indirectly, to recover twice for the same element of Landlord's damages.

20. END OF TERM

20.1 **Improvements.** Upon the termination of this Lease, at Landlord's option (a) all Improvements shall become Landlord's property; or (b) Tenant shall remove all Improvements at no cost to Landlord, and shall leave the Land in a clean and orderly condition free of all debris. Landlord shall Notify Tenant of Landlord's election to have Tenant remove the Improvements not later than ninety (90) days before the Expiration Date.

20.2 **Tenant's Removal of Improvements.** If Tenant is required to remove the Improvements upon termination of the Lease, Tenant shall have reasonable access to the Premises for a period of up to six (6) months after the Expiration Date to dismantle, pack and remove the Improvements from the Premises (the "**Removal Period**"). Tenant shall work promptly and diligently to remove the Improvements. The Removal Period shall end upon Tenant's completion of removal of the Improvements from the Premises. If Tenant fails to remove the Improvements within the Removal Period, the Holding Over provisions of Section 19.6 of this Lease shall apply. The terms and provisions of this

Lease shall apply during the Removal Period, including Tenant's obligations to provide insurance and to Indemnify Landlord.

20.3 Landlord's Removal of Improvements. If Landlord determines that Tenant is not making diligent efforts to remove the Improvements, Landlord shall Notify Tenant of Landlord's intention to remove the Improvements at Tenant's cost. If 30 days after such notice to Tenant Landlord in its reasonable judgment continues to believe Tenant is not diligently removing the Improvements, Landlord may remove the Improvements at Tenant's cost.

20.4 Actions Upon Surrender. Upon the later of (a) any Expiration Date and (b) the expiration of the Removal Period:

20.4.1 Condition of Premises. Tenant shall deliver to Landlord possession of the Premises, in the condition this Lease requires, subject to any Loss that this Lease does not require Tenant to Restore.

20.4.2 Surrender of Premises. Tenant shall surrender any right, title, or interest in and to the Premises and deliver such evidence and confirmation thereof as Landlord reasonably requires.

20.4.3 Free and Clear. Tenant shall deliver the Premises free and clear of all: (a) Subleases, and (b) liens except (i) liens that Landlord or any of its agents caused, or (ii) the recorded title exceptions affecting the Fee Estate that are prior to this Lease as of the Commencement Date and listed as exceptions in Tenant's leasehold policy of title insurance for this Lease.

20.4.4 Assignment of Rights. Tenant shall assign to Landlord, without recourse, and give Landlord copies or originals of, all assignable licenses, permits, contracts, warranties, and guarantees then in effect for the Premises.

20.4.5 Orderly Transition. The parties shall cooperate to achieve an orderly transition of operations from Tenant to Landlord without interruption, including delivery of such books and records (or copies thereof) as Landlord reasonably requires.

20.4.6 Real Estate Taxes. The parties shall adjust for Real Estate Taxes and all other expenses and income of the Premises and any prepaid Rent and shall make such payments as shall be appropriate on account of such adjustment in the same manner as for a sale of the Premises (but any sums otherwise payable to Tenant shall first be applied to cure any Default).

20.4.7 Memorandum of Lease. The parties shall terminate the Memorandum of Lease.

20.4.8 Deposits. Tenant shall assign to Landlord, and Landlord shall reimburse Tenant for, all utility and other service provider deposits for the Premises.

21. NOTICES

21.1 Special Notices. All Notices of Default, Renewal Notices, and similar substantive Notices shall be in writing and addressed to Landlord and Tenant (and their designated copy recipients), and shall be deemed given to a party when (a) delivered to the appropriate address by hand or by nationally recognized overnight courier service (costs prepaid) or (b) received or rejected by the addressee, if sent by certified mail, return receipt requested, in each case to the following addresses and marked to the attention of the person (by name or title) designated below (or to such other address or Person as a party may designate by notice to the other party):

Landlord: Lāna‘i Resorts, LLC
733 Bishop Street, Suite 2000
Honolulu, HI 96813
Attention: Kurt Matsumoto
E-mail: kmatsumoto@pulamalanai.com

With a copy to:
Lāna‘i Resorts, LLC
733 Bishop Street, Suite 2000
Honolulu, HI 96813
Attention: Harrilynn K. Kameenui, Esq.
E-mail: hkameenui@pulamalanai.com

Tenant: _____

Attention: _____
Telephone No.: (____)
Facsimile No.: (____)
E-mail:

21.2 Ordinary Notices. Notices in the ordinary course of business with respect to this Lease (for example for the regular payment of Rent under this Lease as opposed to late payments) shall be in writing and addressed to Landlord and Tenant as provided in the foregoing paragraph, and may be sent by first class mail or e-mail, in which case they shall be deemed delivered three Business Days after deposit in the United States mail, provided that no postal strike (or other event likely to disrupt postal service) is then in effect.

21.3 Change of Address. Either party may change its address by Notice in compliance with this Lease. Notice of such a change shall be effective only upon receipt.

21.4 **Acknowledgment; Notice by Counsel.** Any party giving a Notice may request the recipient to acknowledge receipt of such Notice. The recipient shall promptly comply with any such request, but failure to do so shall not limit the effectiveness of any Notice. Any attorney may give any Notice on behalf of its client.

22. NONRECOURSE

Notwithstanding anything to the contrary in this Lease, the liability under this Lease of Landlord and its parent, subsidiary(ies), or affiliated corporations or other entities, for damages or otherwise, shall be enforceable against, and shall not extend beyond, their interests in the Premises (including the proceeds thereof). No property or assets whatsoever, except Landlord's interest in the Premises (including the proceeds thereof), shall be subject to levy, execution or any other enforcement procedure for the satisfaction of any remedies (monetary or otherwise) of the other party arising under or in connection with this Lease. The limitation of liability and limitation of remedy in this paragraph shall not apply in any way to, and shall not be construed to limit or preclude, personal liability (if any) arising under any Supplementary Agreement. No shareholder, officer, member, manager, director, agent, or employee of Tenant or Landlord shall have any liability under this Lease, but this shall not limit any liability arising under the express terms of any Supplementary Agreement. (This Lease sometimes refers to this paragraph as the "**Nonrecourse Clause.**")

23. ADDITIONAL DELIVERIES; THIRD PARTIES

23.1 **Estoppel Certificates.** Up to twice a year, each party to this Lease (a "**Requesting Party**") may require the other party (a "**Certifying Party**") to execute, acknowledge, and deliver to the Requesting Party (or directly to a designated third party) up to four original counterparts of an Estoppel Certificate. The Certifying Party shall sign, acknowledge, and return such Estoppel Certificate within 15 days after request, even if the Requesting Party is in Default. Any Estoppel Certificate shall bind the Certifying Party.

23.2 **Further Assurances.** Each party shall execute and deliver such further documents, and perform such further acts, as may be reasonably necessary to achieve the parties' intent in entering into this Lease.

23.3 **Memorandum of Lease.** Upon request by either, the parties shall promptly execute, acknowledge, and deliver duplicate originals of a Memorandum of Lease. Either party may record such Memorandum of Lease. Any taxes and fees imposed upon such recording shall be paid by Tenant. If the parties amend this Lease, then the parties shall have the same rights and obligations regarding a memorandum of such amendment as they do for the Memorandum of Lease.

23.4 **Modification.** Any Modification of this Lease must be in writing signed by the party to be bound.

23.5 **Successors and Assigns.** This Lease shall bind and benefit Landlord and Tenant and their successors and assigns, but this shall not limit or supersede any Transfer restrictions.

23.6 **No Third-Party Beneficiaries.** Nothing in this Lease confers on any Person (except Landlord, Tenant, Leasehold Mortgagees, and Fee Mortgagees) any right to insist upon, or to enforce against Landlord or Tenant, the performance or observance by either party of its obligations under this Lease.

24. GUARANTY

24.1 **Guaranty.** Concurrently with the execution and delivery of this Lease, Tenant shall deliver to Landlord a Guaranty in the form attached hereto as **Exhibit C** executed by Guarantor and acknowledged.

25. ARCHAEOLOGICAL AND HISTORICAL ITEMS

25.1 **Discovery of Items.** In the event any human remains, artifacts, historical items, or any of them (collectively the “**Discovered Items**”) are discovered on the Premises, Tenant shall, at Tenant’s sole expense and subject to the approval of Landlord, be responsible to: (a) cause all excavation in the immediate area which may damage the Discovered Items and the potential historic site to cease; (b) cause the site to be stabilized and secured to temporarily protect the Discovered Items against damage, theft, or both; (c) cause the Discovered Items to be left untouched so that their archaeological or historical context may be accurately documented; and (d) cause the discovery to be reported immediately to Landlord and to Government as required by applicable Laws. If the artifacts or historical items are found without human remains, and leaving the artifacts or historical items in their stabilized and secured site poses a substantial risk of loss or damage to all or part of them, and their removal is therefore necessary, Tenant shall cause such removal and shall cause any tampering with the artifacts, the historical items, and the site to be minimized as much as possible.

25.2 **Human Remains.** In the case of the discovery of human remains, Tenant shall, at Tenant’s sole expense and in addition to the duties set forth in this section, cause to be prepared and executed a mitigation plan acceptable to Landlord and to Government possessing jurisdiction over such matters. Tenant shall also be responsible to obtain written verification that the mitigation plan has been successfully implemented.

25.3 **Landlord’s Reservation.** If any Discovered Items are discovered, then Landlord shall have the right at all reasonable times to enter the Premises for the purposes of searching for, exploring for, and removing any of the Discovered Items for preservation as permitted by Law. All objects, antiquities and specimens of Hawaiian or other ancient art or handicraft or of prehistoric, historic or archaeological interest found on the Premises belong to and shall remain the property of Landlord.

25.4 Studies by Tenant. In the event any archaeological studies or historic preservation studies are sought to be conducted in or on the Premises, by Tenant or anyone acting by or through Tenant, Tenant shall not permit such studies to be commenced without the prior written consent of Landlord, unless Tenant is required by applicable Law to permit such studies, in which case Landlord's consent shall not be required but Tenant shall provide Landlord with prior Notice of the commencement of such studies and shall advise Landlord of the applicable Law mandating such studies. In any event, Tenant shall upon completion of such studies cause a complete copy of the results of such studies to be provided to Landlord at the earliest opportunity.

26. MISCELLANEOUS

26.1 Confidential Information. Without limitation of the promises in Section 10.12, each party agrees that, except as otherwise provided by applicable Laws, or in connection with proceedings before the State of Hawaii Public Utilities Commission or other governmental body with jurisdiction over the Premises, or in connection with the evaluation for financing of the Premises, or as part of disclosure to its affiliates, attorneys, consultants, and advisers in order to conduct its business or proceedings to enforce this Lease or the Power Purchase Agreement, or to record a Memorandum of Lease under Section 23.3 of this Lease, such party (including its officers, directors, employees, representatives, brokers, attorneys and advisers) shall keep the contents of this Lease and any information related to the Premises, Tenant and the transaction contemplated by this Lease confidential, whether or not marked as "confidential" (collectively, the "**Confidential Information**"). The Confidential Information shall not include any information publicly known, or which becomes publicly known, other than through the acts of a party to the Lease, or any of their respective officers, directors, employees, representatives, brokers, attorneys or advisers. Tenant may retain possession of all or any part of the Confidential Information to the extent such Confidential Information relates solely to the Property and Tenant's operations thereon.

26.2 Costs and Expenses; Legal Costs. In the event of any litigation or dispute between the parties, or claim made by either party against the other, arising from this Lease or the landlord-tenant relationship under this Lease, or Landlord's enforcement of this Lease upon a Default, or to enforce or interpret this Lease or seek declaratory or injunctive relief in connection with this Lease, or to exercise any right or remedy under or arising from this Lease, or to regain or attempt to regain possession of the Premises or terminate this Lease, or in any Bankruptcy Proceeding affecting the other party to this Lease, the prevailing party shall be entitled to reimbursement of its Legal Costs with Default Interest and all other reasonable costs and expenses incurred in enforcing this Lease or curing the other party's default.

26.3 No Consequential Damages. Whenever either party may seek or claim damages against the other party (whether by reason of a breach of this Lease by such party, in enforcement of any indemnity obligation, for misrepresentation or breach of warranty, or otherwise), neither Landlord nor Tenant shall seek, nor shall there be

awarded or granted by any court, arbitrator, or other adjudicator, any speculative, consequential, collateral, special, punitive, or indirect damages, whether such breach shall be willful, knowing, intentional, deliberate, or otherwise. The parties intend that any damages awarded to either party shall be limited to actual, direct damages sustained by the aggrieved party. Neither party shall be liable for any loss of profits suffered or claimed to have been suffered by the other.

26.4 No Waiver by Silence. Failure of either party to complain of any act or omission on the part of the other party shall not be deemed a waiver by the noncomplaining party of any of its rights under this Lease. No waiver by either party at any time, express or implied, of any breach of this Lease shall waive such breach or any other breach.

26.5 Performance Under Protest. If a dispute arises about performance of any obligation under this Lease, the party against which such obligation is asserted shall have the right to perform it under protest, which shall not be regarded as voluntary performance. A party that has performed under protest may institute appropriate proceedings to recover any amount paid or the reasonable cost of otherwise complying with any such obligation, with interest at the Prime Rate.

26.6 Survival. All rights and obligations that by their nature are to be performed after any termination of this Lease shall survive any such termination.

26.7 No Broker. Each party: (a) represents and warrants that it did not engage or deal with any broker or finder in connection with this Lease and no person is entitled to any commission or finder's fee on account of any agreement or arrangement made by such party; and (b) shall indemnify the other party against any breach of such representation.

26.8 Unavoidable Delay. Each party's obligation to perform or observe any nonmonetary obligation under this Lease shall be suspended during such time as such performance or observance is prevented or delayed by Unavoidable Delay.

27. INTERPRETATION, EXECUTION, AND APPLICATION OF LEASE

27.1 Captions. The captions of this Lease are for convenience and reference only. They in no way affect this Lease.

27.2 Counterparts. This Lease may be executed in counterparts.

27.3 Delivery of Drafts. Neither party shall be bound by this Lease unless and until such party shall have executed and delivered at least one counterpart of this Lease. The submission of draft(s) or comment(s) on drafts shall bind neither party in any way. Such draft(s) and comment(s) shall not be considered in interpreting this Lease.

APPENDIX F ATTACHMENT 2

27.4 Entire Agreement. This Lease contains all terms, covenants, and conditions about the Premises. The parties have no other understandings or agreements, oral or written, about the Premises or Tenant's use or occupancy of, or any interest of Tenant in, the Premises.

27.5 Governing Law. This Lease, its interpretation and performance, the relationship between the parties, and any disputes arising from or relating to any of the foregoing, shall be governed, construed, interpreted, and regulated under the laws of the State, without regard to principles of conflict of laws.

27.6 Partial Invalidity. If any term or provision of this Lease or its application to any party or circumstance shall to any extent be invalid or unenforceable, then the remainder of this Lease, or the application of such term or provision to persons or circumstances except those as to which it is invalid or unenforceable, shall not be affected by such invalidity. All remaining provisions of this Lease shall be valid and be enforced to the fullest extent Law allows.

27.7 No Party Deemed Drafter. No inference in favor of or against any party shall be drawn from the fact that such party has drafted any part of this Lease. The parties have both participated substantially in its negotiation, drafting, and revision, with advice from counsel and other advisers.

27.8 Reasonableness. Wherever this Lease states that a party shall not unreasonably withhold approval: (a) such approval shall not be unreasonably delayed or conditioned; (b) no withholding of approval shall be deemed reasonable unless withheld by Notice specifying reasonable grounds, in reasonable detail, for such withholding, and indicating specific reasonable changes in the proposal under consideration that would make it acceptable; and (c) if a party grants its consent (or fails to object) to any matter, this shall not waive its rights to require such consent for any further or similar matter.

IN WITNESS WHEREOF, Landlord and Tenant have executed this Lease as of the Commencement Date.

LĀNA'I RESORTS, LLC

By its Member, Lanai Island Holdings, LLC

By its Manager, LIH Corporation

APPENDIX F ATTACHMENT 2

By _____
Kurt Matsumoto
Its: Vice President

Landlord

By _____
Its

Tenant

APPENDIX F ATTACHMENT 3

TERM SHEET

**GROUND LEASE BETWEEN L NA'I RESORTS, LLC AND _____,
 FOR PREMISES LOCATED AT L NA'I CITY, L NA'I
 JULY 2020**

THIS TERM SHEET IS PROVIDED FOR GENERAL INFORMATION ONLY. LANDLORD RESERVES THE RIGHT TO REVISE ANY OF THE FOLLOWING TERMS FOR ANY REASON DURING FINAL NEGOTIATIONS

Purpose:	Leasing the Premises for the purpose of building and operating a solar and battery storage facility capable of providing electrical power to MECO's system pursuant to a Power Purchase Agreement ("PPA").
Premises:	Landlord owns the following real property (collectively, the "Premises"): (i) the unsubdivided land described in Exhibit A, consisting of approximately 73 acres of land (the "Land") together with an easement over a roadway (the "Roadway"); (ii) all buildings, structures, and other improvements and appurtenances located on the Land other than any buildings, structures and other improvements or appurtenances that may have been constructed by on or behalf of Tenant prior to the commencement date; and (iii) the appurtenances and all the estate and rights of Landlord in and to the Land.
Commencement Date:	Execution of Lease
Security Deposit:	TBD
Initial Term:	Same Initial Term in PPA
Extended Term:	Same Extended Term in PPA
Fixed Rent (from execution of lease up to commercial operations)	\$200.00 per acre per month, plus all applicable taxes, as long as the PPA remains in effect; or 10% of the Land Value per year, adjusted annually by the CPI Adjustment Factor, commencing on the date a PPA Disconnect occurs and continuing for the period a PPA Disconnect remains in effect.
Fixed Rent (during commercial operations):	50% increase to \$300.00 per acre per month, plus all applicable taxes, as long as the PPA remains in effect; or 10% of the Land Value per year, adjusted annually by the CPI Adjustment Factor, commencing on the date a PPA Disconnect occurs and continuing for the period a PPA Disconnect remains in effect.
Variable Rent:	2% of the monthly gross receipts received during commercial operations from HECO to the Tenant per the negotiated PPA for the Project.
Property Taxes:	Tenant shall pay all Real Estate Taxes and Assessments for the Premises.
Conveyance Tax:	Tenant shall pay the conveyance tax imposed under Hawaii Revised Statutes Chapter 247 due and payable upon the Commencement Date.
Utilities:	Tenant shall arrange and pay for all utility charges, including all installation, maintenance, use and service expenses.
Insurance:	Tenant shall maintain Worker's Compensation, Employer's Liability, Commercial General Liability, Automobile Liability, All Risk Property, Builders and Installation Risk, and Umbrella Liability Insurance Policies in minimum amounts acceptable to Landlord.
Purchase Option:	None
Termination:	This Lease shall expire upon the Expiration Date, termination of the PPA, and the occurrence of an Event of Default

APPENDIX F ATTACHMENT 3

Removal of Improvements:	Upon the termination of the Lease, at Landlord's option (a) all Improvements shall become Landlord's property; or (b) Tenant shall remove all Improvements at no cost to Landlord, and shall leave the Land in a clean and orderly condition free of all debris. Landlord shall Notify Tenant of Landlord's election to have Tenant remove the Improvements not later than ninety (90) days before the Expiration Date.
Lease Guaranty:	Concurrently with the execution and delivery of the Lease, Tenant shall deliver to Landlord a Guaranty in a form acceptable to Landlord.
Assignment and Subletting:	Allowed only with Landlord's prior written consent which may be withheld in Landlord's sole discretion.
Right of First Offer at Expiration Date	Landlord has the right of first offer at the Expiration Date to purchase assets on the Land based on valuation at the end of the Lease.

DRAFT

REQUEST FOR PROPOSALS

FOR

VARIABLE RENEWABLE DISPATCHABLE GENERATION

PAIRED WITH ENERGY STORAGE

AND

COMMUNITY-BASED RENEWABLE ENERGY

ISLAND OF LĀNA‘I

SEPTEMBER 8, 2020

Docket No. 2015-0389

*Appendix G – Self Build Option and
Self Build Option Team Certification Form*

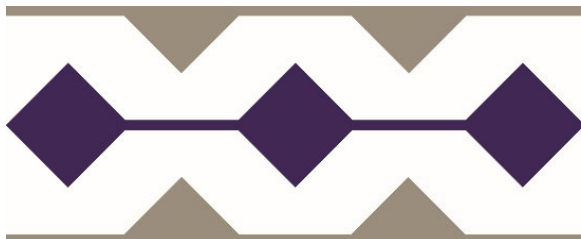

**Maui
Electric**

Appendix G - Self Build Option

Overview

To the extent that there are Self Build Option (“SBO”) Proposals to the RFP, the Company will endeavor to evaluate these SBO Proposals on a fair basis compared to third party Proposals. As described in Section 1.9.1 of the RFP, “[t]he Competitive Bidding Framework allows the Company the option to offer a Proposal(s) in response to this RFP (“Self-Build Option” or “SBO”). Accordingly, the Company must follow certain requirements and procedures designed to safeguard against and address concerns associated with: (1) preferential treatment of the SBO or members, agents or consultants of the Company formulating the SBO (the “Self-Build Team”); and (2) preferential access to proprietary information of the Self-Build Team.” Any Proposal from the Self-Build Team will be required to comply with the provisions in the Framework for Competitive Bidding (“Framework”) as well as this RFP.

In addition to its Proposal, the Self-Build Team will be required to submit Attachment 1 to this Appendix G, Self-Build Option Team Certification Form, acknowledging it has followed the rules and requirements of the RFP to the best of its ability and has not engaged in any collusive actions or received any preferential treatment or information providing an impermissible competitive advantage to the Self-Build Team over other proposers responding to this RFP, as well as adherence to PPA terms and milestones required of all proposers and the SBO’s proposed cost protection measures.

Pursuant to the Framework and as set forth in the RFP Schedule, the Company will require that the Proposal for the SBO be submitted electronically through the Electronic Procurement Platform a minimum of one (1) Day before other Proposals are due.

Except where specifically noted, a SBO Proposal must adhere to the same price and non-price Proposal requirements as required of all Proposers.

As described in Section 3.8.3 of the RFP, if selected, a Self-Build Proposer will not be required to enter into a PPA with the Company. However, the SBO will be held to the same performance metrics and milestones set forth in the RDG PPA to the same extent as all Proposers, as attested to in the SBO’s Appendix G Attachment 1 Self Build Option Certification submittal. If liquidated damages are assessed, they will be paid from shareholder funds and returned to customers through the Purchased Power Adjustment Clause (“PPAC”),

In lieu of price components, the SBO will need to provide their total project capital costs, any associated annual O&M costs, as well as annual revenue requirements by year. (See Appendix B Section 2.0.) The SBO shall submit revenue requirement worksheets with their Proposal that support their annual revenue requirements estimates. A starter revenue requirements template file can be requested by the Self-Build Team via email to the RFP Email Address or through the PowerAdvocate Messaging function once the RFP event opens. The revenue requirements worksheets submitted will

be customized to reflect the details of the Project's Proposal. All assumptions used will be reflected in an assumptions input tab.

SBO Total Project Capital Cost

The following is a high-level breakdown followed by a narrative explanation of the total capital cost estimate for a potential SBO Proposal. The total project capital cost (and annual O&M costs) will be used to calculate the Revenue Requirement, which will then be used to calculate a LB for Proposal comparison purposes. The categories of costs include:

- Facility
 - EPC Contract
 - Allowance for Change Orders
 - Equipment
 - Owner's Cost
- Outside Services
- Interconnection
- Overheads
- AFUDC

These costs will be identified in Section 2.3.2.2 of the SBO Proposal. (See Appendix B Section 2.3.2.2)

- Facility (including any generation and storage components) - This line item, to the extent applicable, should include costs such as:

Engineering, Procurement, and Construction ("EPC") Contract

The total cost estimate of the facility is the projected EPC contract cost including the design of the facility up to the high-voltage terminals of the step-up transformers, procurement of all the equipment, and services necessary to build the facility and construction and commissioning of the facility.

Allowance for Change Orders

This allocation accounts for items such as additional requirements resulting from unforeseen conditions, unexpected permitting requirements, force majeure events, unanticipated interferences, different interpretations of design requirements, material unavailability, and longer than normal delivery times.

Equipment

This cost includes the generator and the facility equipment that support the operation of the generator and the distribution of electrical power around the station, as applicable. Engineering and testing services required to ensure that the equipment is properly functioning at the site, training and documentation necessary to operate and maintain the equipment, and performance guarantees may also be included here.

Owner's Cost

Owner's costs for the facility are all the costs necessary for the design, permitting, procurement, construction, and commissioning of the facility and for the preparation of the Proposal that are not included in the major contracts (i.e. EPC). The Companies' Labor includes Project Management, Station Operator training and commissioning, Environmental, Safety, Legal, Corporate Communications, Community and Government Relations, Engineering, and Regulatory Affairs. Company Labor for the preparation of the Proposal is also included here. For purposes of recovery, only the incremental costs of Labor will be subject to separate recovery.

- Outside Services - This line item, to the extent applicable, should include costs such as:
 - Construction Management to oversee the EPC contractor
 - Legal for the preparation of the Environmental Impact Statement and PUC process
 - Engineering for development and evaluation of the project technical specifications, Interconnection Requirements Study (IRS), and emissions testing
 - Environmental to conduct the Environmental Impact Statement (EIS) and Air Permit consulting
 - General Services such as surveys, land appraisals, Environmental Condition Reports, public relations, office trailer rental, archeological services, landscaping, miscellaneous permits, builder's risk insurance, switchgear testing, hazard analysis, painting, monitoring services, and moving costs.
 - Material costs including spare parts, furnishings, IT equipment, appliances, generator system initial fills (fuels, oils, water), and telecommunications equipment for the station.
 - Travel costs required to inspect other similar facilities, observe final acceptance testing of critical equipment, and station operators' factory training

- Interconnection – This line item covers all interconnection costs that a similarly situated IPP would be responsible for as described in RFP Section 2.3.5, and to the extent applicable, should include costs such as:

Distribution Line

The cost estimate includes the design, procurement, and construction of any new transmission infrastructure needed to interconnect with the designated substation.

Switchyard

Work at the switchyard will include design, procurement, and construction of the switchyard and the interfaces between the high voltage terminals of the generator step-up transformers and the distribution line to which it will be connected. Site

preparation of the switchyard and the design, procurement, and installation of the step-up transformers located in the switchyard, are typically included in the EPC contract.

Substation

Work at the designated substation that will include the design, procurement, and construction of the interfaces between the new distribution line and the substation buswork to which it will be connected.

Telecom

Accounts for direct labor, materials, and outside services to install telecommunication requirements for the project.

Project Management

Cost estimate of the project management design, procurement, contracting, and scheduling efforts for the interconnection only. Project management costs for the facility are included in the Owner's Cost estimate above.

- Overhead Costs

Overhead costs for the proposed facility will be estimated by the Company's budgeting software (UI Planner) and represent an allocation for those Company costs that are not attributable to any particular project or operation, but are essential nonetheless. Overheads are comprised of non-productive wages (such as holiday, sick, and vacation pay), employee benefits, payroll taxes, corporate administrative costs, and clearing costs.

- Allowance for Funds Used During Construction ("AFUDC")

The AFUDC will be calculated using the Company's budgeting software (UI Planner) and represents the cost of capital funding for the Project. The Company strives to minimize the cost of the AFUDC by ensuring that Project elements that are used or useful are placed in service as soon as possible, as well as minimizing the amount of time that AFUDC can accumulate, by minimizing the amount of time between expenditures on Project elements and their placement in service.

The SBO Proposal will include a Revenue Requirement for each year, which is calculated from the total project capital cost to determine the revenues needed to recover the cost of the project. The value of the Revenue Requirement Calculation for the Total SBO Project Capital Cost will be included in the Levelized Benefit calculation described below.

Annual O&M

The cost for ongoing O&M (fixed and variable) will be a component of the Revenue Requirement. All O&M should be included in this category, unless captured elsewhere in the Revenue Requirement Calculation, including but not limited to annual O&M expense to maintain facility; property taxes (if applicable), and insurance. As described in RFP Appendix G, a SBO Proposal

will be required to cap its O&M costs at the amount included in the Proposal. Only actual costs will be recovered if such actual costs are lower than the maximum amounts in the Proposal.

Annual Revenue Requirement

The SBO Proposal will include a Revenue Requirement for each year, which is calculated from the total project capital cost to determine the revenues needed to recover the cost of the project. The value of the Revenue Requirement Calculation for the Total SBO Project Capital Cost will be included in the Levelized Benefit calculation.

The following is a narrative description of the proposed revenue requirement calculation and significant assumptions that the SBO Proposal should account for. The objective of a revenue requirement analysis is to illustrate the annual revenue requirements (ARR) for a utility SBO Proposal.

Revenue Requirement is defined as a calculated value which represents the estimated revenues needed from ratepayers which would allow the Company to recover its capital investment and expenses, honor its debt obligations, pay its revenue and income tax liabilities, and pay its preferred shareholders while providing a fair return to its common shareholders for their investment. Specific factors or assumptions related to that particular project will be included in the analysis.

The purpose of a revenue requirement calculation is to determine the annual and total revenue requirements of a capital investment and annual O&M expense needed from customers. The ratemaking formula for revenue requirements is shown below.

$$RR = O + T + D + r(RB)$$

Where: RR = Revenue Requirements
 O = Operating and Maintenance Expense
 T = Tax Expense (Income and Revenue)
 D = Depreciation Expense
 r = Rate of Return on Rate Base
 RB = Rate Base

The Company, in conjunction with the Independent Observer, may also conduct a risk assessment of the SBO Proposal to ensure an appropriate level of customer cost protection measures are included in such proposal.

APPENDIX G ATTACHMENT 1 - SELF BUILD OPTION TEAM CERTIFICATION

Name of SBO Team Contact: _____

Unique Name of Facility: _____

This Certification of the Self Build Option (SBO) Team’s SBO Proposal for Hawaiian Electric Company, Inc., Maui Electric Company, Ltd, and Hawai’i Electric Light Company, Inc.’s (the “Hawaiian Electric Companies”) Variable Renewable Dispatchable Generation Paired with Energy Storage and Community-Based Renewable Energy Request for Proposal (RFP) is made as of the date stated below.

A. COMPLIANCE WITH THE RFP AND CODE OF CONDUCT

The SBO Team certifies and acknowledges that it will/has:

1. Adhered to the terms of the RFP applicable to the SBO Team, including but not limited to: Section 1.7.1 (proposal submittal requirements), Section 1.7.3 (certification of non-collusion), Section 1.9 (Procedures for the Self-Build or Affiliate Proposals), and Section 3.4.4 (authorized signatory);
2. Adhered to the technical requirements of the RFP, excluding however those requirements inapplicable to the SBO Team such as execution of the Model PV RDG PPA), pricing formula requirements for independent power producer proposals, submission of a Proposal Fee, dispute resolution, and credit requirements;
3. Complied with the Company’s Code of Conduct Procedures Manual, attached as Appendix C to this RFP, with particular attention to the Communications Protocols described in Section C therein with respect to communication with the Company RFP Team.

B. INDEPENDENT INVESTIGATION

The SBO Team further certifies and acknowledges that it will/has:

1. Submitted the SBO Proposal based on its own investigations, examinations, and determinations, including assessments of any risks that could have an effect on its obligations under the SBO Proposal.
2. Carefully examined the Company’s RFP documents and its appendices and has a clear and comprehensive knowledge of what is required of a Proposer under the RFP, and correspondingly, what is required of the SBO Team.
3. Examined and understands the technical requirements, schedule, and evaluation process as it is laid out in the RFP.

C. COST PROPOSAL ACKNOWLEDGEMENTS

The Self Build Team acknowledges and agrees that:

1. Recovery for Project capital costs and O&M costs will be capped at the amount included in the SBO Team's SBO Proposal.
2. Only actual capital costs and O&M costs will be recovered even if such actual costs are lower than the SBO Team's proposed maximum amounts.
3. Costs of developing the proposal must be included in the SBO for evaluation purposes only. Only the incremental costs of developing the SBO Team's proposal will be charged to the project and passed through to customers. Incremental costs for the SBO Proposal not serving as the Parallel Plan and which are not selected to the Final Award Group will not be recoverable from the Companies' customers.

D. ADHERENCE TO PPA REQUIREMENTS AND MILESTONES

The Self Build Team acknowledges and agrees that:

1. The SBO Proposal will be consistent with the scope of work and responsibilities of the "Seller" under the terms of the applicable Model PPA excluding inapplicable terms related to commercial and legal interactions between the Seller and the Company.
2. The SBO Facility will be designed and constructed to:
 - a. Achieve the Performance Standards identified in Section 3 - Performance Standards, in Attachment B of the applicable Model PV RDG PPA as modified by the IRS (subject to reasonable adjustment agreeable to the Company consistent with the Company's negotiation of such performance standards that would be completed with an independent power producer under similar circumstances);
 - b. Meet the performance metrics as specified in Article 2 of the applicable Model PV RDG PPA.
 - b.1. For the photovoltaic generation component of the facility, (i) PV System Equivalent Availability Factor, and (ii) Measured Performance Ratio;
 - b.2. For the storage component of the facility, (i) Storage Annual Equipment Availability Factor, (ii) Storage Annual Equivalent Forced Outage Factor, and (iii) Storage Capacity Ratio;
 - c. Pass the Acceptance Test specified in Attachment N – Acceptance Test General Criteria of the applicable Model PV RDG PPA.
 - d. Pass the Control System Performance Test specified in Attachment O – Control System Acceptance Test Criteria of the applicable Model PV RDG PPA;

- e. Pass the On-line Performance Test specified in Attachment W – BESS Capacity Test of the applicable Model PV RDG PPA;
- f. Achieve a Demonstrated Capacity equal to or greater than that indicated in the SBO Proposal as measured pursuant to Attachment W – BESS Capacity Test of the applicable Model PV RDG PPA;
- g. Meet the project milestones identified in the SBO Proposal no later than the dates specified therein, which shall be consistent with the guaranteed project milestones required in Attachment K – Guaranteed Project Milestones of the applicable Model PV RDG PPA (subject to reasonable adjustment agreeable to the Company consistent with the Company’s negotiation of such milestones that would be completed with an independent power producer under similar circumstances). Notice of completion of milestones and any delay will be provided to PUC and Consumer Advocate.
- h. Achieve the reporting milestones identified in the SBO Proposal no later than the dates specified therein, which shall be consistent with the reporting milestones required in Attachment L – Reporting Milestones of the applicable Model PV RDG PPA (subject to reasonable adjustment agreeable to the Company consistent with the Company’s negotiation of such milestones that would be completed with an independent power producer under similar circumstances). Notice of completion of milestones and any delay will be provided to PUC and Consumer Advocate.
- i. Will be subject to the applicable liquidated damages for the applicable Model PV RDG PPA provisions above. These liquidated damages would be paid from shareholder funds and would be passed through to customers through the Companies’ Power Purchase Adjustment Clause. Notice of any liquidated damages assessed and amounts of such liquidated damages will be provided to PUC and Consumer Advocate.
- j. Will reconfirm requirements in GO7 application and any resulting approval order for such application.
- k. Will provide annual report to PUC and Consumer Advocate on performance metrics.

E. DECLARATION AND SIGNATURE

- 1. The individual(s) that has (have) signed this Self Build Option Team Certification is (are) duly authorized by the SBO Team to execute such on behalf of the SBO Team; and
- 2. All statements, specifications, data, confirmations, and other information set out in this Self Build Option Team Certification are complete and accurate in all material respects.

IN WITNESS WHEREOF, the SBO TEAM hereby makes the certifications, acknowledgements, and agreements stated herein as of the date stated under the signature of its authorized representative:

Dated at _____, _____ this _____ day of _____ 20_____.

Signature of SBO Team Representative

Name of SBO Team Representative (please print)

Title of SBO Team Representative (please print)

DRAFT

REQUEST FOR PROPOSALS

FOR

VARIABLE RENEWABLE DISPATCHABLE GENERATION

PAIRED WITH ENERGY STORAGE

AND

COMMUNITY-BASED RENEWABLE ENERGY

ISLAND OF LĀNA‘I

SEPTEMBER 8, 2020

Docket No. 2015-0389

*Appendix H – Interconnection Facilities and
Cost Information*

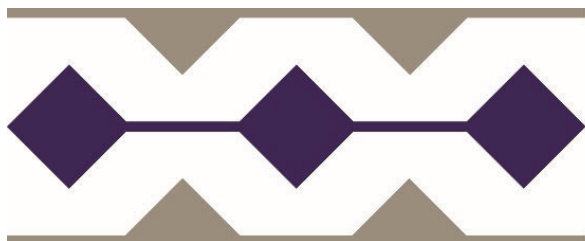

**Maui
Electric**

Maui Electric

APPENDIX H - INTERCONNECTION FACILITIES AND COST INFORMATION

Tariff Rule No. 19, approved by the PUC, establishes provisions for Interconnection and Transmission Upgrades (see Appendix I). The tariff provisions are intended to simplify the rules regarding who pays for, installs, owns, and operates interconnection facilities in the context of competitive bidding. Unless otherwise specified in this RFP, Tariff Rule No. 19 will be utilized as the basis for addressing interconnection and transmission upgrades for any projects developed through this RFP. Proposers will comply with the terms and conditions as specified therein.

To assist Proposers in assessing the impacts of location on potential projects, the per unit cost figures provided in the tables below are to be used to provide an approximate estimated cost for interconnecting, including communications and distribution line cost to the existing Lānaʻi Electric System. The per-unit cost figures below should not be used to create a detailed project estimate. A detailed project estimate typically requires a certain level of engineering to assess project site conditions and to factor in other parameters specific to the project.

The Proposer should identify the components assumed for their project and the quantity assumed for each. Each table below provides notes on the assumptions for each of the unit cost estimates. If a Proposer’s project requirements are different than what is assumed in the notes, the Proposer should identify each difference and provide an estimated additional cost or savings resulting from those different requirements.

2.1 Distribution Line Costs

Component	Description	Approximate Cost per Mile
1	New 12kV Overhead line (accessible 250' spans)	\$1,020,000
2	12 kV underbuild on existing line (accessible 250' spans)	\$735,000
3	12 kV underbuild on existing line (inaccessible 250' spans)	\$1,292,000
4	New 12kV Underground line	\$1,369,000
5	Padmount service 500 kVA transformer (for station service)	\$89,000
6	PME9 and PME3 switches for 1-ph and 3-ph transformers	\$307,000

Notes:

1. Component 1 assumes wood pole construction.
2. Components 2 and 3 assume no poles need to be replaced.
3. Component 4 assumes one set of 1000 KCM AL 15kV (600A) cable but does NOT include duct bank and MH construction.
4. Exclusions to these rough costs are as follows but not limited to the following, Proposers should conduct their own due diligence for these costs:
 - a. Development of the PUC application/proceedings timeline

Maui Electric

APPENDIX H - INTERCONNECTION FACILITIES AND COST INFORMATION

- b. State or County right-of-way permitting and SMA
 - c. Environmental studies cost
 - d. Survey of proposed line extension route
 - e. Easement/land issues if discovered in the course of final design
 - f. Archaeological survey and monitoring cost/duration (if needed)
 - g. Clearing/grading along power line corridor and access road
 - h. Final design adjustments required to negotiate terrain, physical landmarks, existing utilities and access
 - i. Construction of permanent roadways/truck access
 - j. Helicopter services
 - k. Traffic control
 - l. Removals (Maui Electric & Hawaiian Telcom as applicable)
 - m. Salvage and depreciation credits
 - n. Street lights
 - o. Delays due to weather and material acquisitions
 - p. Civil infrastructure (duct bank, MH, equipment pads, etc.) construction
5. All estimates are provided in 2022 dollars.
6. The customer shall be responsible to confirm if independent station power is required. Meter requirements should be discussed with Maui Electric during the customer’s design stage. Station power shall emanate from an existing 12kV distribution line to the customer’s point of connection, either by overhead utility poles or underground line extension. For underground line extensions, the customer shall be responsible for installing and maintaining the infrastructure consisting of, but not limited to, concrete encased ducts, manholes/handholes, transformer and switchgear pads, and meter equipment.

2.2 Miki Basin Interconnection Costs

2.2.1 Substation 12kV Interconnection Costs VARIABLE Projects

Component	Description	Approximate Cost
1	2 – 12kV switchgear additions (Maui Electric)	\$1,200,000

Notes:

- 1. Please refer to Attachment 1 of this Appendix H for a single line diagram depicting the required interconnection to the Company’s Miki Basin substation.
- 2. Conceptual Design is not intended to cover all interconnection requirements. Final interconnection design will be subject to the results of the IRS.
- 3. Substation land has been graded per Maui Electric’s civil and structural requirements. No costs for excavation and fill are included in the estimates.
- 4. Permits are not included in indicated costs.

Maui Electric

APPENDIX H - INTERCONNECTION FACILITIES AND COST INFORMATION

5. Costs are in 2020 dollars.
6. Estimate does not contain any of the following costs:
 - a. Telecommunication infrastructure
 - b. Relay coordination study
 - c. Land cost
 - d. Environmental Assessment/Environmental Impact Statement
 - e. Project management
 - f. Any required upgrades to existing substations to integrate the new generating facility into the system.
7. Substation relay protection requirements have not been identified, so costs are based upon typical line protection relaying requirements.
8. Local SCADA equipment are included in cost estimates.
9. The estimate is for addition of Miki Basin switchgear, which does not contain any cost for the conceptual design for RFP interconnection.
10. The estimate does not contain any line extension cost.
11. The largest unit size shall be limited to 2.5MW net export.

2.3 Telecommunications

All projects that require telecommunications will require facilities to store the communications equipment. An example for a communications cabinet is provided but other alternatives can be available upon request. The communications equipment will require a communications channel. Some of the communication channel options include microwave, fiber, lease line, or licensed radio. The number of communication circuits (primary/backup) and type of communication circuits required will vary depending on the type/size of the project.

1. Microwave Equipment

- a. Point-To-Point Microwave: \$684,117 with the following assumptions:
 - i. There is radio line-of-sight clearance between the communication endpoints.
 - ii. FCC licensed Microwave Frequencies are available.
 - iii. There are existing structures/buildings with space available on both ends to house the radio equipment.
 - iv. Telecommunications grounding standards are up-to-date at both sites.
 - v. 48 V DC power with 12 hour battery backup is available.
 - vi. This estimate does not include any special site-specific permit/approval activities that may be required including, but not limited to, Neighborhood Board (s), Conservation District Use Application, Environmental Assessment, Shoreline Management Area approval, biological (endangered species or habitat) surveys, and/or cultural (archeological) surveys or the cost of any migration required for approvals to be granted.

Maui Electric

APPENDIX H - INTERCONNECTION FACILITIES AND COST INFORMATION

- vii. Space is available at both ends to construct antenna towers or structures that are rated to survive a Saffir-Simpson category 4 hurricane.
 - viii. Cost to interconnect to Hawaiian Electric's existing communications network is not included.
 - ix. Costs are in 2022 dollars.
 - b. 50 Foot Microwave Tower: \$591,021 with the following assumptions:
 - i. Telecommunications grounding standards are up-to-date.
 - ii. This estimate does not include any special site-specific permit/approval activities that may be required including, but not limited to, Neighborhood Board (s), Conservation District Use Application, Environmental Assessment, Shoreline Management Area approval, biological (endangered species or habitat) surveys, and/or cultural (archeological) surveys or the cost of any migration required for approvals to be granted.
 - iii. Costs are in 2022 dollars.
 - c. 100 Foot Microwave Tower: \$858,563 with the following assumptions:
 - i. Telecommunications grounding standards are up-to-date.
 - ii. This estimate does not include any special site-specific permit/approval activities that may be required including, but not limited to, Neighborhood Board (s), Conservation District Use Application, Environmental Assessment, Shoreline Management Area approval, biological (endangered species or habitat) surveys, and/or cultural (archeological) surveys or the cost of any migration required for approvals to be granted.
 - iii. Costs are in 2022 dollars.
2. Fiber with overbuild and new construction – \$456,000 per mile with the following assumptions:
 - a. Accessible 250' average spans.
 - b. The poles are in good condition and do not need replacing.
 - c. The poles are not overloaded.
 - d. The poles and the attachments are in accordance with NESC 2002 and no work is required to upgrade the poles to current standards.
3. Leased Line: Cost will be the responsibility of the developer and to be negotiated with the lease provider.
 - a. Communication circuit requirements will be based on applications needed for the project.
 - b. Company can provide communication circuit interconnection requirements and assist with order review as needed.
4. Communications Cabinet: \$207,365 with the following assumptions:
 - a. Cabinet used to support company equipment and capable of providing communications circuit for SCADA

Maui Electric

APPENDIX H - INTERCONNECTION FACILITIES AND COST INFORMATION

- b. Communications cabinet does not include fiber, microwave, or lease circuits.
 - i. Customer to work directly with lease provider if a lease line circuit is needed.
 - ii. Check with company to understand the current lease requirements.
 - c. Customer will provide all conduits, PAD, handholes, AC Power, grounding as required per company standards.
 - d. Cost are in 2022 dollars.
5. Licensed 900 MHz Radio: \$143,626 with the following assumptions:
- a. This cost will be in addition to the Communication Cabinet cost. The radio equipment will be installed within the Communication Cabinet.
 - b. There is radio line-of-sight clearance between the communication endpoints.
 - c. FCC licensed 900Mhz Frequencies is available.
 - d. There is an existing structure/building with space available on the company side to mount the antenna equipment and house the radio equipment.
 - e. The customer will install a structure to mount the antenna equipment on the customers side.
 - i. Customer will provide any conduit required between the Communications Cabinet and antenna mount structure.
 - f. The cost includes 2 each antenna equipment to create a radio link.
 - g. Cost are in 2022 dollars.

2.4 Security System

2.4.1 Proposals for interconnection via a new substation on a 12 kV network circuit

- 1. Equipment/Electronics for security – \$350,000 with the following assumptions:
 - a. Civil facilities associated with security (e.g., site fencing, conduits for security systems) for the new 12 kV substation, costs are included under Item 2.2.1.1 above.
 - b. Systems incorporated will be equivalent to the Tier 1 requirements identified in the table below for Company facilities.
 - c. Costs are in 2020 dollars.

2.4.2 Proposals for interconnection via a new substation on a 12 kV radial circuit

- 1. Equipment/Electronics for security – \$350,000 with the following assumptions:
 - a. Civil facilities associated with security (e.g., site fencing, conduits for security systems) for the new 12 kV substation, costs are included under Item 2.2.2.1 above.
 - b. Systems incorporated will be equivalent to the Tier 1 requirements identified in the table below for Company facilities.

Maui Electric

APPENDIX H - INTERCONNECTION FACILITIES AND COST INFORMATION

c. Costs are in 2020 dollars.

2.4.3 The developer shall be responsible to incorporate security components and systems for **their facilities** that consider the Security Guidelines for the Electricity Sector (CIP-014-2): Physical Security, as published by the North American Electric Reliability Corporation (NERC) and that at a minimum adhere to Company's performance requirements outlined in Company's Physical Security Strategy for the following four security concepts.

- **Deter:** Deploy visible physical security measures to encourage individuals to seek other, less secure targets.
- **Detect:** Utilize state of the art physical security technologies to detect unauthorized intrusion and provide real-time alerts to monitoring personnel. Detection to include 24/7 monitoring personnel.
- **Delay:** Deploy multiple physical security countermeasures to delay an intruder's access to assets and provide time for incident assessment and appropriate response.
- **Respond:** Take immediate measures to assess, interrupt, and/or respond to the incident, including notification to Company and the use of contracted patrol personnel and/or the involvement of law enforcement assets to apprehend an intruder.

The Company's Physical Security Strategy is available upon request after execution of an NDA with the Company.

Maui Electric

APPENDIX H - INTERCONNECTION FACILITIES AND COST INFORMATION

Based on the Facility size requested through this RFP, the Facility will need to meet Tier One security requirements. These requirements will be subject to final review during the design and engineering phase. Additional information is available upon request after execution of an NDA with the Company.

Type of Facility	Tier One High Criticality	Tier Two Medium Criticality	Tier Three Lower Criticality
Substation	<ul style="list-style-type: none"> • FLIR or Similar camera perimeter monitoring. • Secondary perimeter intrusion detection system. • Interior Video monitoring system with motion detection. • Gunfire detection/IP intercom public address system. • Electronic card access system for control & microwave houses. • Standard 8' high security fence with 3-strand barbed wire V-top. • Interior mounted 4' high cattle fencing. • LED perimeter lighting. • All gates will be secured using a proprietary padlock system. 	<ul style="list-style-type: none"> • Video monitoring system with motion detection. • Card access on control and microwave houses. • Standard 8' high security fence with 3-strand barbed wire V-top. • Interior mounted 4' high cattle fencing. • All gates will be secured using a proprietary padlock system. 	<ul style="list-style-type: none"> • Standard 8' high security fence with 3-strand barbed wire V-top. • Interior mounted 4' high cattle fencing. • All gates will be secured using a proprietary padlock system.

SUB. 302
MIKI BASIN PP

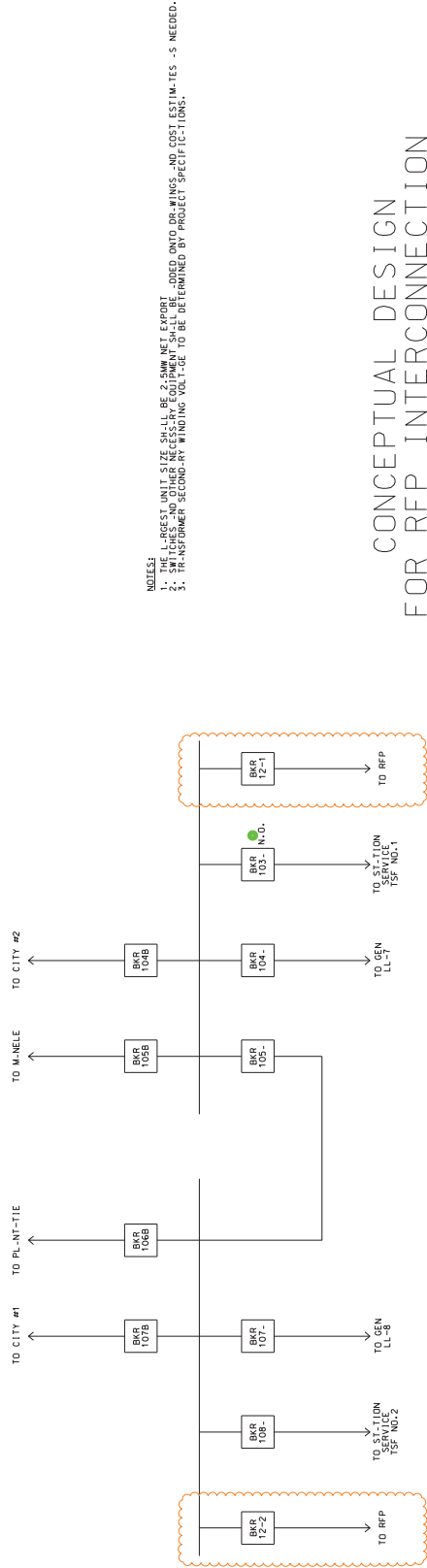

- NOTES:
 1. THE LARGEST UNIT SIZE SHALL BE 2.5MW NET EXPORT
 2. ALL GENERATING EQUIPMENT SHALL BE RATED ON A NET BASIS AND COST ESTIMATES -S NEEDED.
 3. TRANSMISSION WINDING VOLTAGE TO BE DETERMINED BY PROJECT SPECIFICATIONS.

CONCEPTUAL DESIGN
FOR RFP INTERCONNECTION

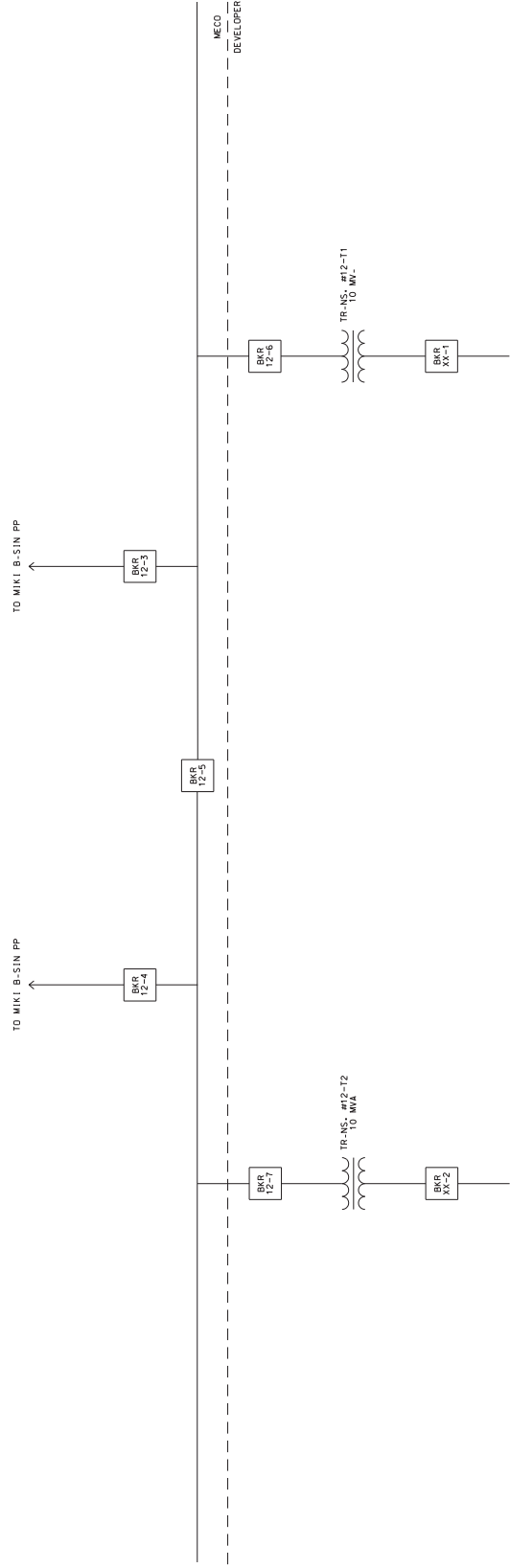

To collector system, design must comply with single point of failure requirement.

To collector system, design must comply with single point of failure requirement.

The intent of having two feeds to Miki Basin is to provide redundancy in the event of planned or unplanned outage of equipment. The interconnection design should be able to provide the instantaneous maximum (8.5MW/10MVA) through a single feed.

DRAFT

REQUEST FOR PROPOSALS

FOR

VARIABLE RENEWABLE DISPATCHABLE GENERATION

PAIRED WITH ENERGY STORAGE

AND

COMMUNITY-BASED RENEWABLE ENERGY

ISLAND OF LĀNA‘I

SEPTEMBER 8, 2020

Docket No. 2015-0389

Appendix I – Rule 19 Tariff

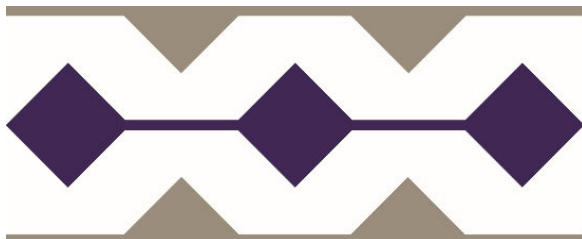

**Maui
Electric**

RULE NO. 19

Interconnection and Transmission Upgrades

A. GENERAL

1. Definitions

- a. "Betterment" means and includes any upgrading to a facility made solely for the benefit of and at the election of the Company, not attributable to the interconnection requirements. The Betterment includes any provisions for future expansion which cannot be charged to replacement. It also includes any related system work beyond that required for interconnection. If an existing facility is replaced with one of greater functional capacity or capability, the difference between the upgraded facility and a replacement facility of equivalent functional capacity is considered Betterment. It does not mean the substitution of a replacement facility for an existing facility, that is, an underground facility for an overhead facility, unless otherwise provided for in the RFP.

Example 1: A substation with a three breaker scheme is required to connect the Generating Facility to the grid. If the Company installs a substation with a six breaker ring bus scheme, the difference between installing a substation with a three breaker scheme and one with a six breaker scheme would be the Betterment.

Example 2: A transmission line needs to be upgraded to accommodate a new Generating Facility. The existing line is designed to withstand a 56 mph wind speed. The project includes upgrading the facilities to withstand a 100 mph wind speed. The increase in the design to the 100 mph wind speed criteria would be the Betterment.

Example 3: A transmission line needs to be upgraded to accommodate a new Generating Facility. In response to the Company's application to upgrade the line, the Commission orders that the line be placed underground. The cost difference between the overhead upgrade and the installation of the underground facilities would not be considered Betterment.

- b. "Company's Dispatch" means the Company's sole and absolute right to control, from moment to moment, through Supervisory Control, or otherwise, and in accordance with good engineering and operating practices in the electric utility industry, the rate of delivery of energy offered by the bidder to the Company.
- c. "Company's System" means the electric system owned and operated by the Company (to include any non-utility owned facilities) consisting of power plants, transmission and distribution lines, and related equipment for the production and delivery of electric power to the public.

MAUI ELECTRIC COMPANY, LIMITED

RULE NO. 19 - Continued

Interconnection and Transmission Upgrades

- d. "Distribution System" means all electrical wires, equipment, and other facilities at the distribution voltage levels (such as 25kV, 12kV, or 4kV) owned or provided by the Company, through which the Company provides electrical service to its customers.
- e. "Framework" means the Framework for Competitive Bidding dated December 8, 2006, adopted by the Commission in Docket No. 03-0372, Decision and Order No. 23121, which provides the mechanism for acquiring a future energy generation resource or a block of generation resources by the Company.
- f. "Generating Facility" means a bidder or utility-owned electrical energy generation resource that is interconnected to the Company electrical grid.
- g. "Grid Connection Point" means the point at which Interconnection Facilities connect to the Company's System, normally the Company's transmission grid. Facilities from the Generating Facility to the Grid Connection Point shall be considered Interconnection Facilities (see examples given in Attachment A). The Grid Connection Point will be identified in the IRS.
- h. "Interconnection Agreement" means a contract with the bidder that specifies the terms and conditions under which Interconnection Facilities (and, in some cases, certain System Upgrades) will be designed, installed, paid for, owned, operated and/or maintained. In some instances, such terms and conditions may be included in the PPA with a bidder, instead of in a separate Interconnection Agreement.
- i. "Interconnection Facilities" means the equipment and devices required to permit a Generating Facility to operate in parallel with and deliver electric energy to Company's System and provide reliable and safe operation of, and power quality on, the Company's System (in accordance with applicable provisions of the Commission's General Order No. 7, Company tariffs, operational practices and planning criteria), such as, but not limited to, transmission and distribution lines, transformers, switches, and circuit breakers.

Example 1: A wind farm facility constructed on a neighbor island (e.g. Molokai) that exports to the Company the energy it produces would be required to install undersea transmission lines to interconnect the Generating Facility to the Company's System. The undersea transmission lines and related facilities would be considered Interconnection Facilities.

MAUI ELECTRIC COMPANY, LIMITED

RULE NO. 19 - Continued

Interconnection and Transmission Upgrades

Example 2: A proposed Generating Facility is remotely located in a region of the island where there are no existing Transmission System facilities. In this case, if the size of the Generating Facility requires that it be tied to the existing Transmission System, the new Transmission System facilities (i.e. all electrical wires, equipment, and other facilities at the transmission voltage level) constructed from the Generating Facility to the Company's existing Transmission System facilities would be considered Interconnection Facilities.

- j. "Interconnection Requirements Study (IRS)" means a study, performed in accordance with the terms of the IRS Letter Agreement and with the applicable terms of the RFP and any resulting PPA, to identify the Interconnection Facilities, System Upgrades and other system requirements and all associated costs to integrate the proposed Generating Facility with the Company's System, and includes a detailed steady-state and a dynamic analysis. The IRS is conducted by the Company or its consultant and the bidder is responsible for the cost of conducting the IRS.
- k. "Interconnection Requirements Study Letter Agreement (IRS Letter Agreement)" means the letter agreement and any written, signed amendments thereto, between the Company and the bidder that describes the scope, schedule, and payment arrangements for the IRS.
- l. "IRP" means an electric utility's Integrated Resource Plan that has been submitted to the Commission for review and approval in the utility's IRP proceeding, in accordance with the Commission's IRP Framework.
- m. "IRP Framework" means the Commission's Framework for Integrated Resource Planning, dated May 22, 1992, as amended by In re Public Util. Comm'n, Docket No. 05-0075, Decision and Order No. 22490, filed on May 26, 2006.
- n. "Point of Interconnection" means the point of delivery of Energy and/or Capacity supplied by the bidder to the Company, where the facilities owned by the bidder interconnect with the facilities owned or to be owned by the Company. The bidder shall own and maintain the facilities from the Generating Facility to the Point of Interconnection. The Company shall own and maintain the facilities from the Point of Interconnection to the Company's System (see examples given in Attachment A). The Point of Interconnection will be identified in the IRS.
- o. "PPA" means a power purchase agreement or contract by the Company to purchase firm capacity, energy, or both.

MAUI ELECTRIC COMPANY, LIMITED

RULE NO. 19 - Continued

Interconnection and Transmission Upgrades

- p. "Renewable Energy Facility" means a Generating Facility that generates electricity using renewable energy as the source.
- q. "RFP" means a written request for proposal issued by the Company to solicit bids from interested third-parties, and where applicable from the Company or its affiliate, to supply a future generation resource or a block of generation resources to the Company pursuant to a competitive bidding process.
- r. "Subtransmission System" means all electrical wires, equipment, and other facilities at the subtransmission voltage levels (such as 46kV, 35kV, or 23kV) owned or provided by the Company, through which the utility provides electrical service to its customers.
- s. "Supervisory Control" means remote monitoring and/or control of a Generating Facility's power output and interrupting device status by means of a communication channel that is acceptable to the Company. For Generating Facilities intending to export power with an aggregate export capacity greater than 250kW, computerized supervisory control may be required to ensure the safety of working personnel and prompt response to system abnormalities in case of islanding of the Generating Facility. The Company shall determine the need for supervisory control based upon the results of the initial technical screening and/or IRS. Supervisory control shall include at a minimum monitoring of: (a) gross generation by the Generating Facility; (b) feedback of Watts, Vars, WattHours, current and voltage; (c) Vars furnished by the utility; and (d) status of the interrupting device. In addition, the supervisory control will allow the Company to trip the interrupting device during emergency conditions. Monitoring will be performed by system dispatchers or operators at the Company's control center.
- t. "System Benefit" means a material increase in power flow capability or in the reliability of the Company's electrical system from a system-wide perspective.
- u. "System Upgrades" means improvements made to the Company's System, other than the Interconnection Facilities, required to provide reliable and safe operation of, and power quality on, the Company's System (in accordance with applicable provisions of the Commission's General Order No. 7, Company tariffs, operational practices and planning criteria) when the Generation Facility is interconnected with the Company's System (see Attachment A). Such improvements may include, but are not limited to, new transmission or distribution lines, reconstruction or reconductoring of existing lines, circuit breakers, switches, transformers, buses, protective devices, communications, and substation equipment and facilities.

MAUI ELECTRIC COMPANY, LIMITED

RULE NO. 19 - Continued

Interconnection and Transmission Upgrades

v. "Transmission System" means all electrical wires, equipment, and other facilities at the transmission voltage levels (such as 138kV or 69kV) owned or provided by the utility, through which the utility provides electrical service to its customers.

2. Application of Tariff

This Tariff shall apply to an RFP issued pursuant to the Framework and Interconnection Requirement Studies arising from the RFP process. In the event that there is a conflict between any provision of this Tariff and that of an RFP issued pursuant to the Framework and reviewed by the Commission in accordance with Sections III.B.2 and IV.B.6.e. of the Framework, the provisions of the RFP shall prevail. The terms and conditions established in a PPA arising from the RFP and approved by the Commission shall ultimately control over the requirements and terms of both this Tariff and the RFP.

3. Independent Observer

As established in the Framework, the duties and responsibilities of an Independent Observer (IO) include, among other duties and responsibilities, reviewing and monitoring the Company's communications, methods, and implementation of this Tariff, the RFP and related IRS processes.

B. INTERCONNECTION STUDY PROCESS FOR COMPETITIVE BIDDING

1. RFP Package Data -- available to all prospective bidders.

RFP packages issued by the Company shall contain general and regional system information to provide prospective bidders with high level guidance relating to the Company's existing transmission infrastructure. For example, RFP packages may include information in the form of an island map with areas of the Transmission System identified that are at or near their loading limits to provide high level guidance to bidders on areas of the island with transmission constraints. These constraints may include "load pockets", which are load-driven transmission constraints as well as areas of generation-driven transmission constraints. Because transmission impacts are to a large extent specific to the characteristics of supply-side proposals, definitive transmission information cannot be provided in these maps. Detailed geographic maps of the transmission system may not be part of this information due to security concerns. Rather, a map of the island with areas of the map shaded to identify areas (rather than circuits) of transmission constraints, may be provided.

MAUI ELECTRIC COMPANY, LIMITED

RULE NO. 19 - Continued

Interconnection and Transmission Upgrades

In addition, the RFP shall include applicable transmission planning criteria that will be used in the determination of interconnection requirements and potential Transmission System impacts. The information in the bid package will provide bidders with information (a) that should help in the selection of the proposed project's characteristics, including project site, project size, and project mode of operation, and (b) to estimate the interconnection requirements associated with their Generating Facilities and the opportunity to reflect the costs of the interconnection requirements in their bids.

2. Information Requests During Bidding Process - available to all prospective bidders.

During the bidding process, if a prospective bidder requires clarification or additional technical or operational information pertaining to the Company's System, a written request with specific questions may be submitted to the Company in accordance with the requirements set forth in the RFP. The written request, specific questions, and written Company response will be provided to all bidders.

3. RFP Requirements and Threshold Criteria Screening - evaluation performed on all bids received

Each bid received will be reviewed to ensure that it satisfies all of the RFP and threshold criteria requirements. The Company will determine whether each bid conforms to the specified RFP requirements and meets the minimum threshold criteria. Applicable performance standards may be part of the threshold criteria. These performance standards may vary depending upon factors such as the size of the generating resource(s) being acquired in the RFP, the Company's ability to dispatch the Generating Facility, the operational status (e.g., as-available vs. firm) of the Generating Facility, and the fuel type of the Generating Facility (e.g., run-of-the-river hydro may have different performance standards from wind power).

4. High Level Evaluation -- performed on all bids that pass threshold screening in RFP process
 - a. All bids which pass the threshold screening in the RFP process will undergo a high level evaluation consistent with the requirements identified in the RFP, which will focus primarily on basic steady-state analyses (e.g., identifying thermal line impacts, voltage impacts, and any obvious "fatal flaws").

MAUI ELECTRIC COMPANY, LIMITED

RULE NO. 19 - Continued

Interconnection and Transmission Upgrades

- b. For each bid, a high level estimate of the costs of Interconnection Facilities and required System Upgrades will be developed based solely on the high level evaluation identified in Section B.4.a. of this Tariff and on unitized cost estimates (e.g., \$/mile for 138kV line, \$/transformer).
 - c. Results of the high level evaluation and high level estimate of the costs of Interconnection Facilities and required System Upgrades will be factored into the determination of which bids make the short list based on the requirements specified in the RFP.
 - d. Basic curtailment analysis of the proposed Generating Facility and related impacts to operations of existing Generating Facilities may also be factored into the determination of which bids make the short list based on the requirements specified in the RFP.
5. Full Interconnection Requirements Study - performed only on short list bids.
- a. An IRS shall be performed only for bid(s) that have met the RFP requirements, passed the threshold criteria, and made the short list, or as otherwise specified in the RFP.
 - b. An IRS would be performed either serially starting with the bid evaluated as the most competitive at the point of the evaluation process, then proceeding to the next most competitive bid on the short list or in parallel on all or some of the short list bidders simultaneously. The determination of whether or not IRS work is to be performed serially, in parallel, or a combination of the two will be based upon factors such as resource availability, number of short list bids, RFP schedule, and relative competitiveness of one bid to others, and the availability of all information and data from bidders necessary to perform the IRS work
 - c. The Company may if practicable "bundle" IRS work for multiple short list bids into a single IRS if the bids are, among other factors, technically, operationally and geographically (e.g., size, location, technology, timing, operating characteristics, etc.) identical or sufficiently similar to each other.
 - d. The results of the IRS, including identified Interconnection Facilities, System Upgrades, Point of Interconnection, and Grid Connection Point, will be provided to the bidder.
 - e. Bidders shall be responsible for incorporating the costs of their Interconnection Facilities into their bids. The RFP may provide bidders with an opportunity to revise their pricing proposals under certain circumstances. Any pricing change, if permitted under the terms of the RFP, will prompt a re-evaluation of short list bidders in the selection of the winning bid as provided for in the RFP.

MAUI ELECTRIC COMPANY, LIMITED

RULE NO. 19 - Continued

Interconnection and Transmission Upgrades

- f. The Company may perform the analyses included in the IRS, or the IRS or parts of the IRS may be contracted to an outside consultant specializing in such analyses for complex situations or in situations where the Company does not have available resources to conduct the analyses in a time frame agreeable to the Company.
 - g. The scope and cost of the IRS will depend on the complexity of the Company's System and Generating Facility that must be modeled, and the degree to which the Generating Facility will affect the Company's System.
 - h. The bidder will be responsible for the cost of the IRS (or such lesser amount as the Company may specify to facilitate the processing of interconnection requests for similarly situated facilities) to be performed in order to evaluate the impacts of the Generating Facility's interconnection to the Company's System.
- C. INTERCONNECTION COST AND SYSTEM UPGRADE COST ALLOCATION FOR COMPETITIVE BIDDING
- 1. The bidder shall be responsible for the cost of Interconnection Facilities and shall be responsible for the installation and maintenance of Interconnection Facilities from the Generating Facility to the Point of Interconnection, unless otherwise specified in the RFP.
 - 2. Interconnection Facilities from the Generating Facility to the Point of Interconnection shall be built by the bidder, unless the Company agrees otherwise.
 - 3. Interconnection Facilities from the Point of Interconnection to the Grid Connection Point shall be built by the Company and paid for by the bidder, unless the Company agrees or determines otherwise. The Company may elect to include Betterments to Interconnection Facilities from the Point of Interconnection to the Grid Connection Point, and such Betterments shall be paid for by the Company. The cost of Betterments to such Interconnection Facilities will not be considered in the bid evaluations. The bidder shall acquire the necessary land and easements for Interconnection Facilities from the Point of Interconnection to the Grid Connection Point, unless the Company agrees otherwise. Interconnection Facilities from the Point of Interconnection to the Grid Connection Point, if built by the bidder, shall be transferred to the Company upon completion, along with the necessary land rights and easements.

MAUI ELECTRIC COMPANY, LIMITED

RULE NO. 19 - Continued

Interconnection and Transmission Upgrades

4. The Company shall install and maintain the identified System Upgrades arising from the interconnection of the Generating Facility and shall be responsible for the cost of such System Upgrades.
 - a. The Company's cost for System Upgrades will be considered as a factor in the bid evaluations.
 - b. The degree to which the System Upgrades provide System Benefits and/or Betterments will be considered in the bid evaluations.
5. Standards and Interconnection Agreements
 - a. Interconnection Facilities and System Upgrades owned or to be owned by the Company shall be constructed in accordance with the Company's applicable standards and in accordance with the PPA or the Interconnection Agreement, if there is a separate Interconnection Agreement.
 - b. Generating Facilities and Interconnection Facilities owned by the bidder shall be constructed in accordance with applicable State and County code requirements and in accordance with the PPA or the Interconnection Agreement, if there is a separate Interconnection Agreement.
 - c. The bidder's Generating Facility may be interconnected and operated in parallel with the Company's System in accordance with the terms and conditions of the PPA between the Company and the bidder, and/or the terms and conditions of an Interconnection Agreement between the Company and the bidder, if there is a separate Interconnection Agreement.
 - d. The bidder will be required to furnish, install, operate, and maintain suitable and sufficient equipment, to maintain adequate records, and to follow such operating procedures, as may be specified by the Company to protect the Company's System from damage resulting from the parallel operation of the Seller's Facility, including the equipment, records and operating procedures more fully described in the PPA and/or Interconnection Agreement, if there is a separate Interconnection Agreement.
 - e. Interconnection Facilities shall be designed, installed operated and maintained in accordance with good interconnection practice. The objectives of good interconnection practice include, but are not limited to,
 1. Safety - To protect the safety of utility personnel, utility customers, and the public.

MAUI ELECTRIC COMPANY, LIMITED

RULE NO. 19 - Continued

Interconnection and Transmission Upgrades

2. Reliability - To maintain the reliability of the utility system for all utility customers.
 3. Power Quality - To provide for acceptable power quality and voltage regulation on the utility system and for all utility customers.
 4. Restoration - To facilitate restoration of power on the utility system.
 5. Protect Utility and Customer Equipment - To protect utility and customer equipment during steady state and faulted system operating conditions.
 6. Protect Generating Facilities - To protect generating facilities from operation of utility protective and voltage regulation equipment.
 7. Utility System Overcurrent Devices - To maintain proper operation of the utility system's overcurrent protection equipment.
 8. Utility System Operating Efficiency - To ensure operation at appropriate power factors and minimize system losses.
- f. The bidder shall obtain, at its expense, any and all authorizations, approvals, permits, and licenses required for the construction and operation of its Generating Facility and the interconnection of its Generating Facility with the Company's System, including but not limited to environmental permits, building permits, rights of way, or easements.
 - g. Where any Company-owned Interconnection Facilities are to be located on the site of the bidder's Generating Facility, the bidder shall provide, at no expense to the Company, a location and access acceptable to the Company for all such facilities.
6. Renewable Energy Facilities
- a. In its IRP process, the Company may propose System Upgrades, to be paid for, owned and maintained by the utility, to encourage the development of Renewable Energy Facilities.
 - b. In its IRP process, the Company may propose to pay for Interconnection Facilities between the Point of Interconnection and the Grid Connection Point, in order to encourage the development of Renewable Energy Facilities.

MAUI ELECTRIC COMPANY, LIMITED

RULE NO. 19 - Continued

Interconnection and Transmission Upgrades

Attachment A

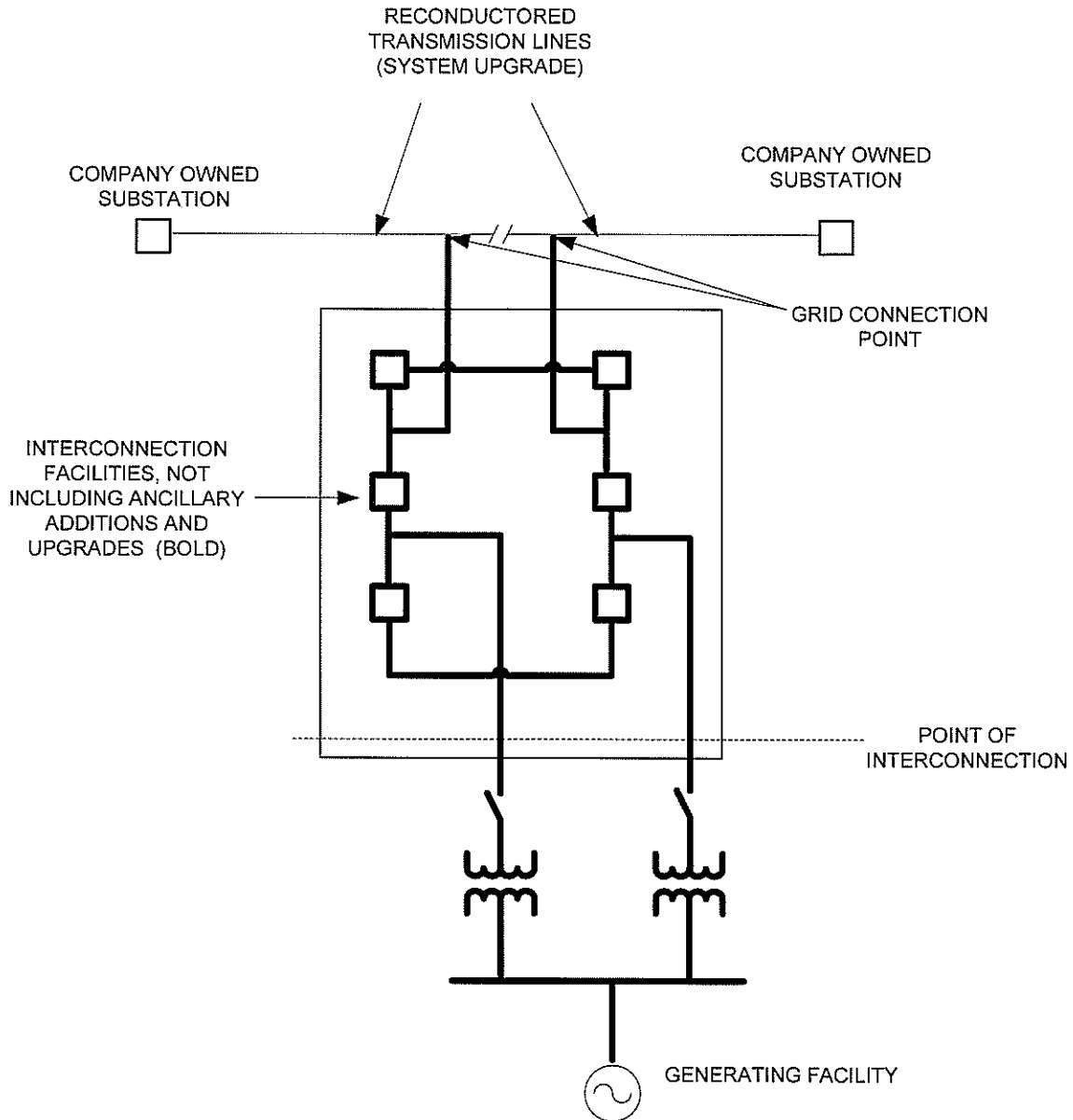

MAUI ELECTRIC COMPANY, LIMITED

DRAFT

REQUEST FOR PROPOSALS

FOR

VARIABLE RENEWABLE DISPATCHABLE GENERATION

PAIRED WITH ENERGY STORAGE

AND

COMMUNITY-BASED RENEWABLE ENERGY

ISLAND OF LĀNA‘I

SEPTEMBER 8, 2020

Docket No. 2015-0389

Appendix J – Rule 29 Tariff

[NOTE: Please refer to Exhibit 4 of the September 8, 2020 filing for the proposed Maui Electric Rule No. 29]

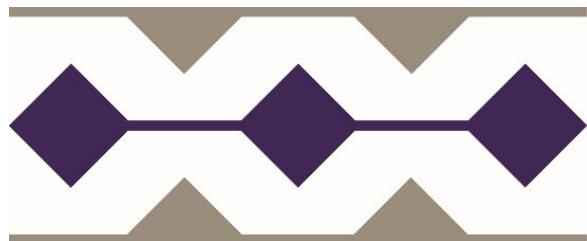

**Maui
Electric**

DRAFT

REQUEST FOR PROPOSALS

FOR

VARIABLE RENEWABLE DISPATCHABLE GENERATION

PAIRED WITH ENERGY STORAGE

AND

COMMUNITY-BASED RENEWABLE ENERGY

ISLAND OF LĀNA‘I

SEPTEMBER 8, 2020

Docket No. 2015-0389

Appendix K – Lāna‘i Community Comments

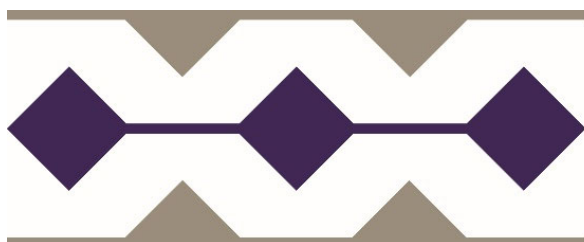

**Maui
Electric**

Lānaʻi Community Meeting Feedback (written comments received by Maui Electric Co., Ltd.)

On July 23, 2019, the Company held a community meeting on Lānaʻi to provide residents information on its plans to conduct a Request for Proposals (“RFP”) for Variable Renewable Dispatchable Generation. During the meeting, the Company gave a presentation to explain the objective of the RFP and overall process.¹ Approximately 40 residents attended the meeting. The Company solicited written feedback from the Lānaʻi community based on the following question:

1: Do you have any feedback/comments you want developers to be aware of?

The following written responses were received:

Comment 1:

Suggest bidders be strongly encouraged to meet w public before submitting bid for consideration to better inform public engagement process if selected~

Comment 2:

Please pronounce the name of our island correct Lānaʻi.

Comment 3:

Price and reliability are major considerations.

What are the plans for restoring power should there be failures, e.g., spare parts readily available on island, technicians on island or can be on island quickly.

Comment 4:

Is the location of the new solar going to take away hunting designated land.

Tell the PUC to bring back net metering?

Can the grid handle the increase in power?

Comment 5:

Is it possible to hire/train Lānaʻi residents to fill these new jobs please?

Will you consider including students at Lānaʻi High & Elem if they would like to learn more about renewable energy?

Comment 6:

So glad MECO incorporated significant opportunities for lots of community input.

¹ The July 23, 2019 meeting was held in conjunction with the scope and Section 3.11 Project Site specified in the Variable Renewable Dispatchable Generation RFP issued on November 27, 2019.

DRAFT

REQUEST FOR PROPOSALS

FOR

VARIABLE RENEWABLE DISPATCHABLE GENERATION

PAIRED WITH ENERGY STORAGE

AND

COMMUNITY-BASED RENEWABLE ENERGY

ISLAND OF LĀNA‘I

SEPTEMBER 8, 2020

Docket No. 2015-0389

Appendix L – Lāna‘i RDG PPA (PV + Storage only)

[NOTE: Please refer to Exhibit 18 of the September 8, 2020 filing for the proposed Maui Electric Rule No. 29]

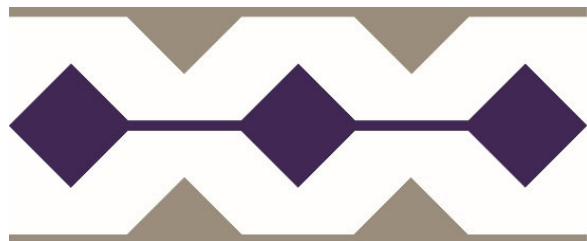

**Maui
Electric**

DRAFT

REQUEST FOR PROPOSALS

FOR

VARIABLE RENEWABLE DISPATCHABLE GENERATION

PAIRED WITH ENERGY STORAGE

AND

COMMUNITY-BASED RENEWABLE ENERGY

ISLAND OF LĀNA‘I

SEPTEMBER 8, 2020

Docket No. 2015-0389

Appendix M – RESERVED

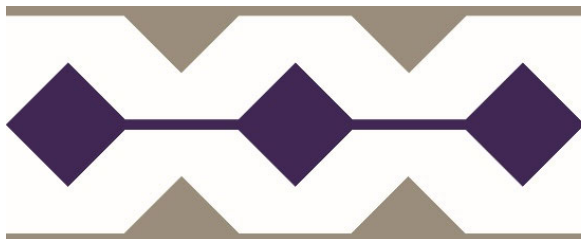

**Maui
Electric**

DRAFT

REQUEST FOR PROPOSALS

FOR

VARIABLE RENEWABLE DISPATCHABLE GENERATION

PAIRED WITH ENERGY STORAGE

AND

COMMUNITY-BASED RENEWABLE ENERGY

ISLAND OF LĀNA‘I

SEPTEMBER 8, 2020

Docket No. 2015-0389

Appendix N – RESERVED



**Maui
Electric**

DRAFT

REQUEST FOR PROPOSALS

FOR

VARIABLE RENEWABLE DISPATCHABLE GENERATION

PAIRED WITH ENERGY STORAGE

AND

COMMUNITY-BASED RENEWABLE ENERGY

ISLAND OF LĀNA‘I

SEPTEMBER 8, 2020

Docket No. 2015-0389

Appendix O – Grid Needs Assessment

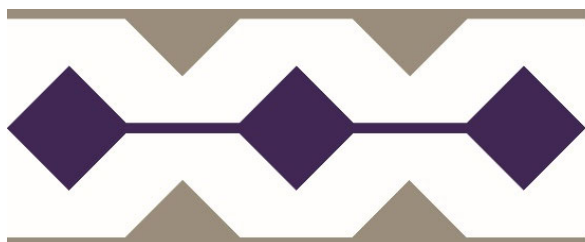

**Maui
Electric**

This Appendix provides the definitions for the grid services considered in the CBRE RFPs and charts for the grid needs and marginal avoided cost values. The grid services were defined as part of the Integrated Grid Planning (“IGP”) Solution Evaluation & Optimization Working Group (“SEOWG”) activities. Bidders may use the information provided in this appendix to understand the grid needs in order to structure their proposals to provide the most value to the Companies.

Grid Service Definitions

The following grid services are used to identify the grid needs.

Table 1: Grid Service Definitions

Grid Service	Definition
Energy	A continuous, controllable, and predictable supply of megawatt-hours to serve system load needs in response to Company Dispatch. ¹
Regulating Reserves	A reserve capacity provided by generating and load resources to allow continuous energy balance over the next 1 minute and 20 to 30-minute time interval due to the variability in renewable resources and load that can be called upon in response to Company Dispatch

Grid Needs

The charts below describe the seasonal and annual hourly need for the services described in Table 1.

¹ “Company Dispatch” as defined in the PPA and SFC means Company's right, through supervisory equipment or otherwise, to direct or control both the capacity and the energy output of the Facility from its minimum output rating to its maximum output rating consistent with this Agreement (including, without limitation, Good Engineering and Operating Practices and the requirements set forth in Section 3 (Performance Standards) of Attachment B (Facility Owned by Subscriber Organization to this Agreement), which dispatch shall include real power, reactive power, voltage, frequency, the determination to cycle a unit off-line or to restart a unit, the droop control setting, the ramp rate setting, and other characteristics of such electric energy output whose parameters are normally controlled or accounted for in a utility dispatching system.

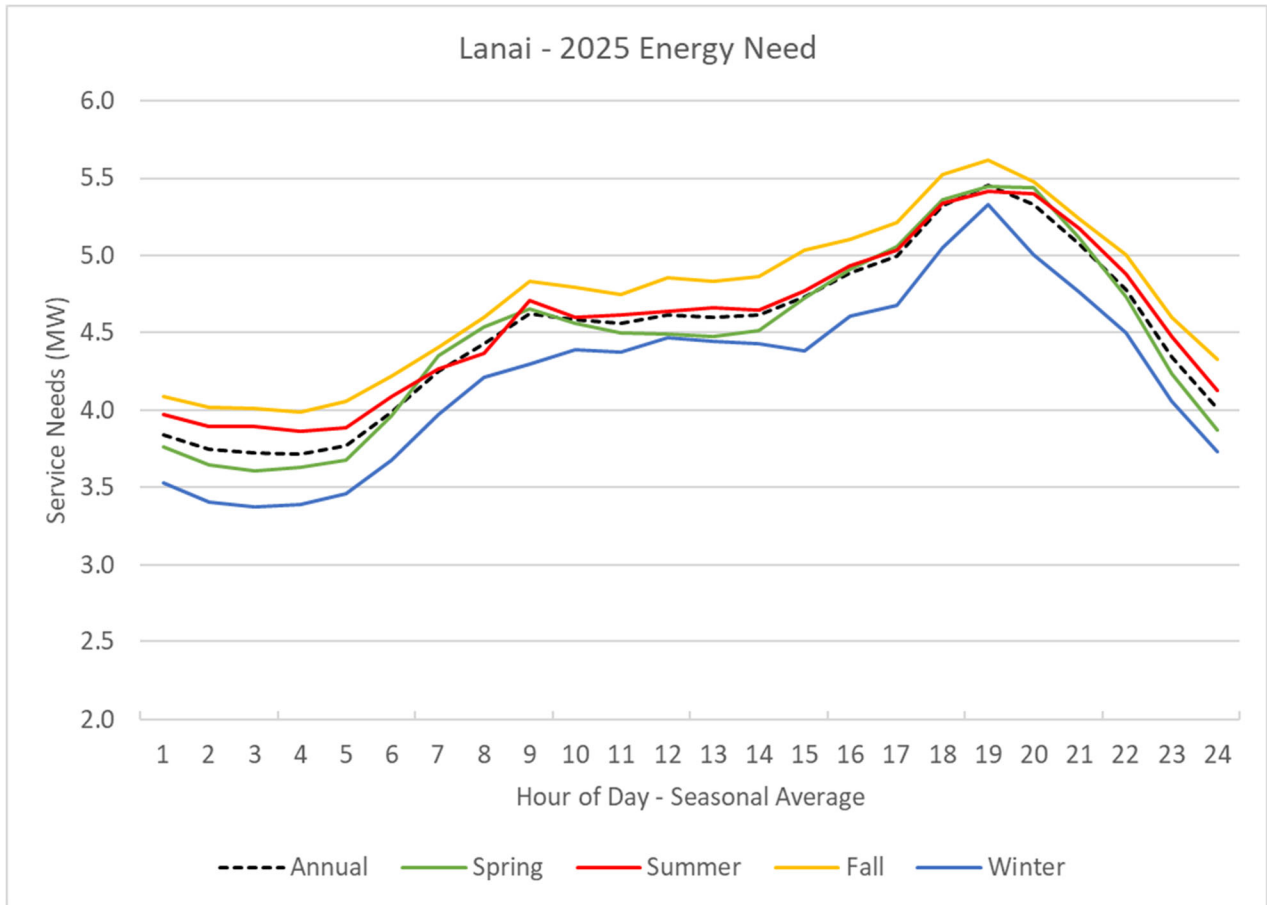

Figure 1: Lana'i 2025 Need for Energy

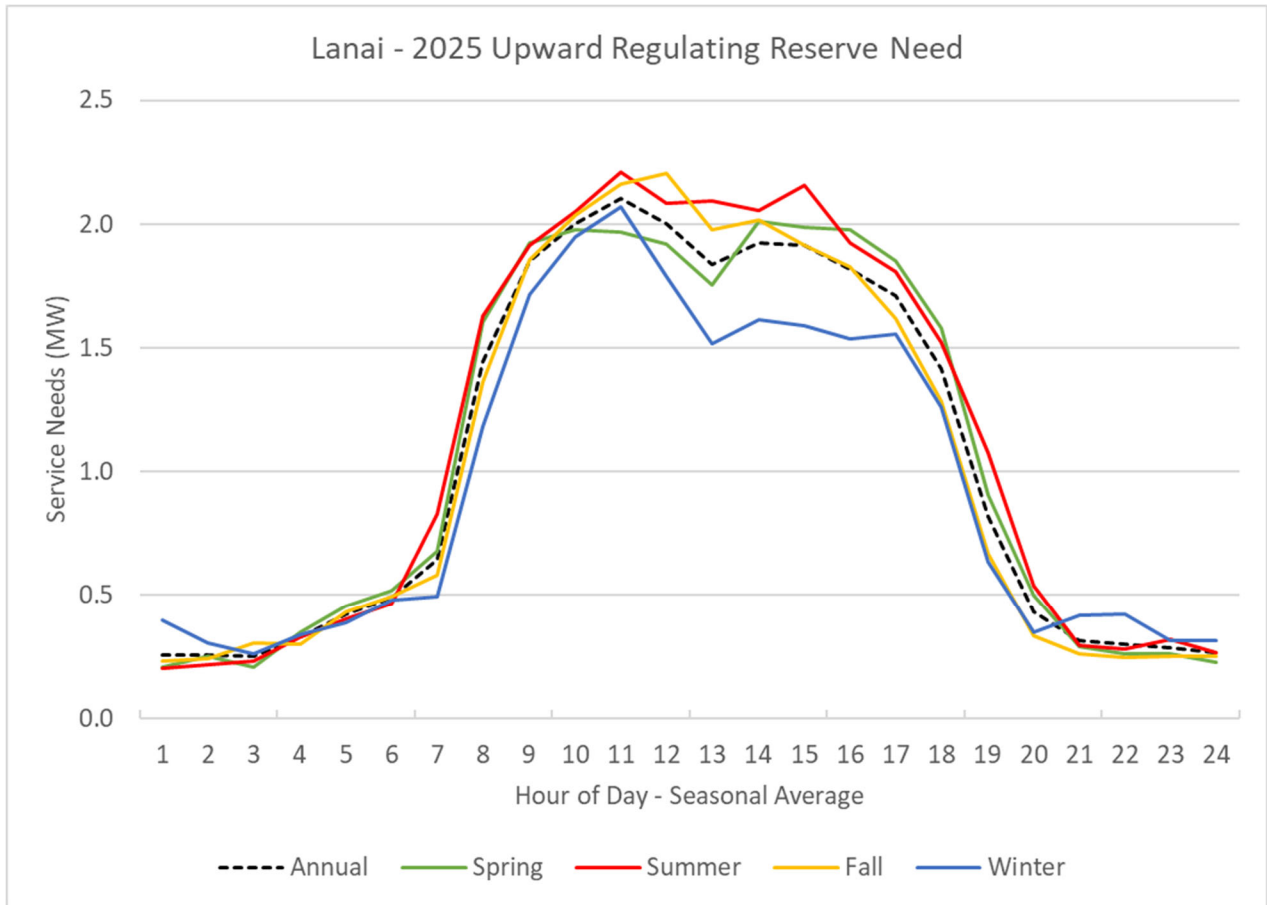

Figure 2: Lana'i 2025 Need for Upward Regulating Reserve

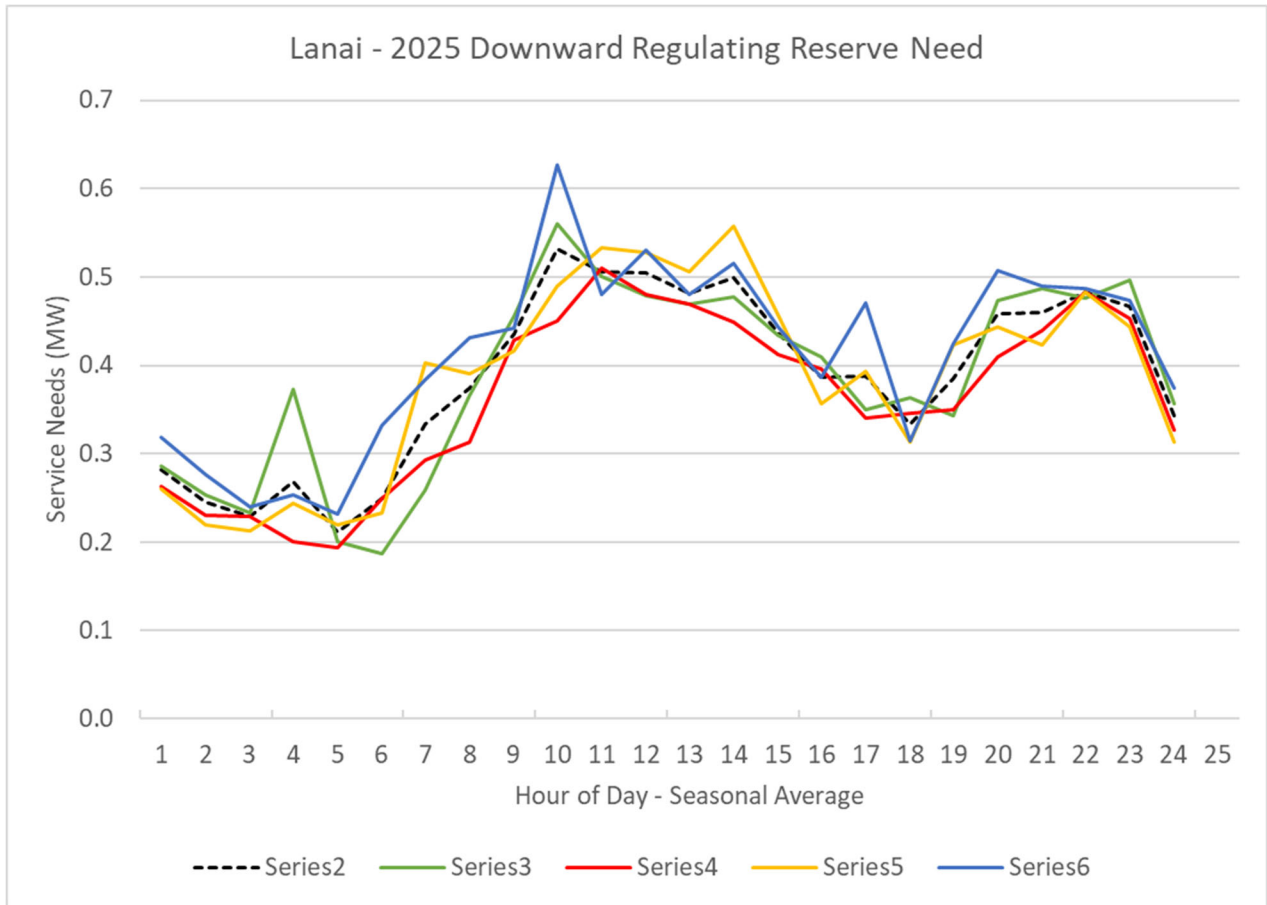

Figure 3: Lana'i 2025 Need for Downward Regulating Reserve

Grid Service Values

The charts below provide the relative marginal avoided costs for the grid services provided in Table 1.

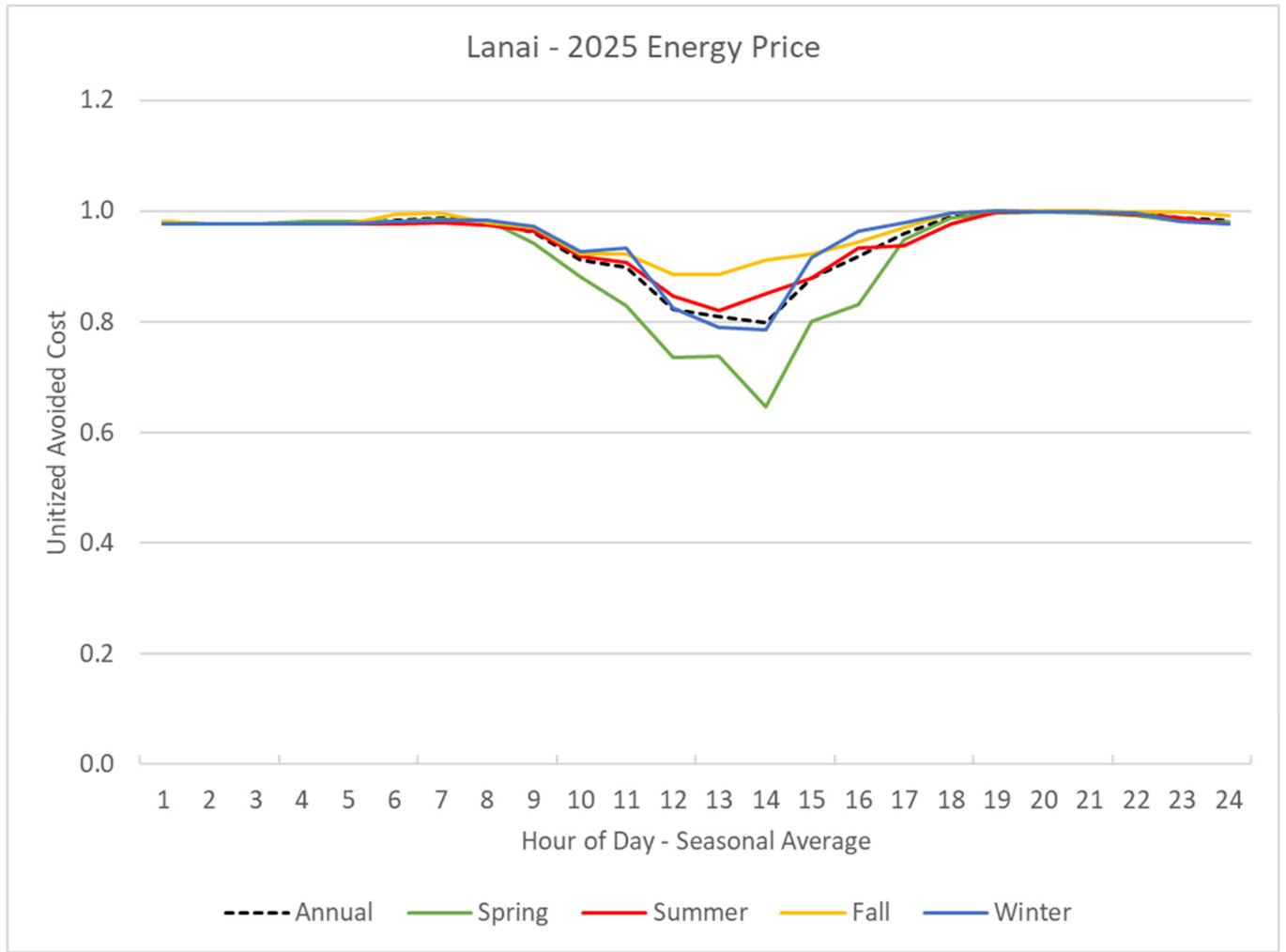

Figure 4: Lana'i 2025 Price for Energy

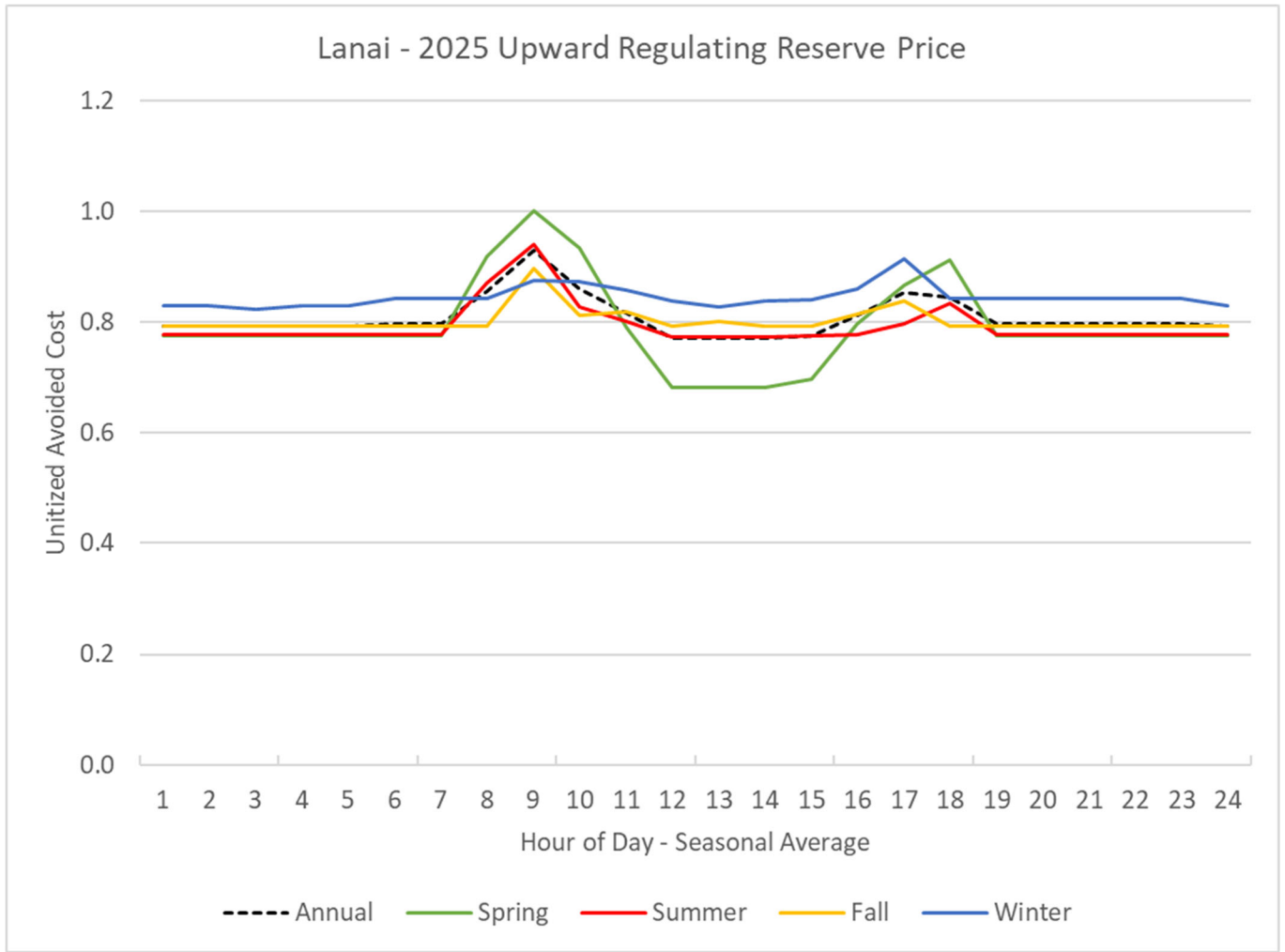

Figure 5: Lana'i 2025 Price for Upward Regulating Reserve

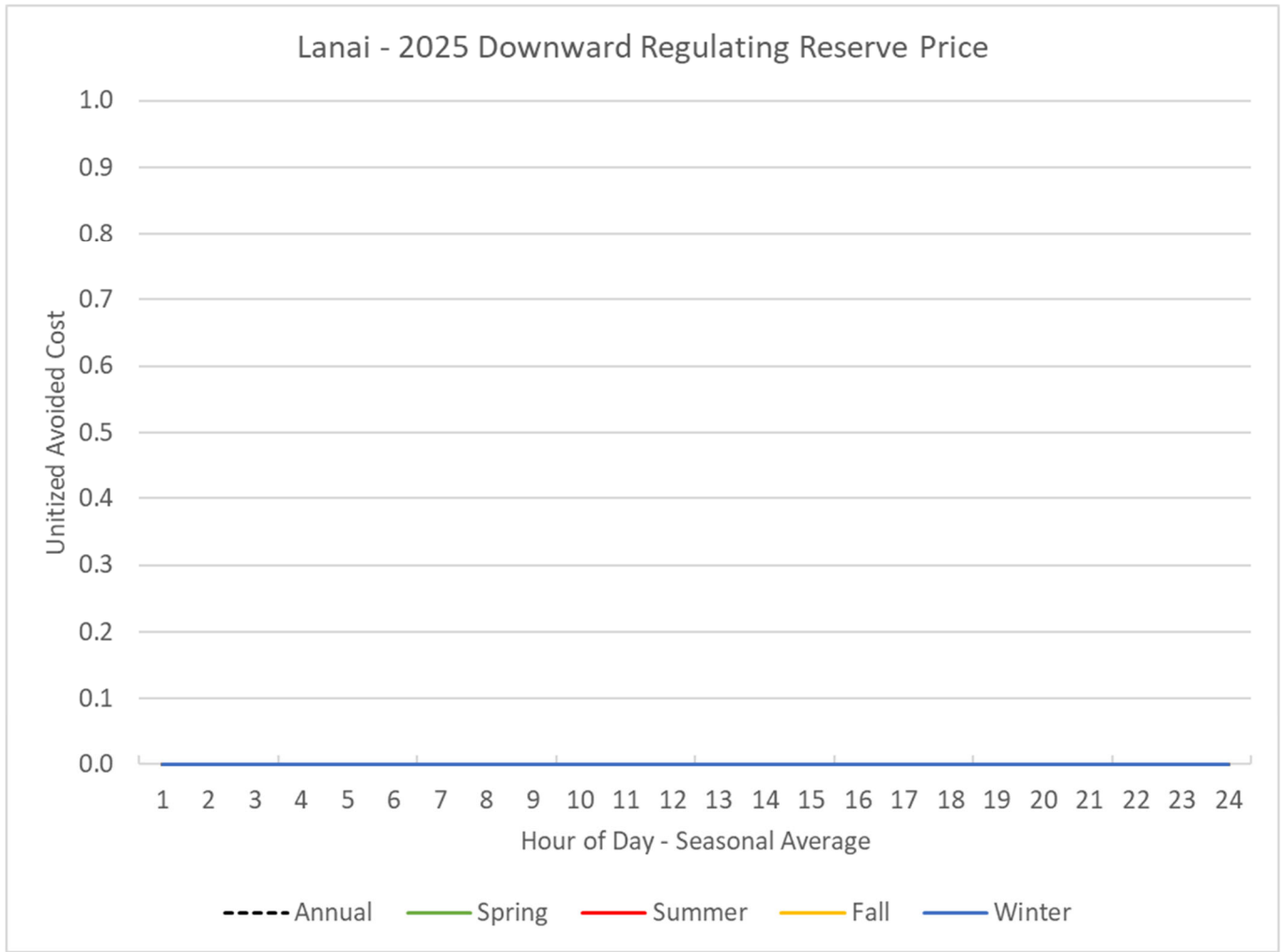
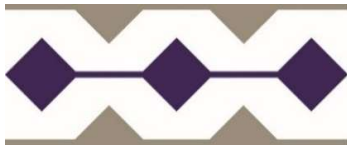

Figure 6: Lana'i 2025 Price for Downward Regulating Reserve

EXHIBIT 10

CBRE Maui / Hawaii

Mid-Tier Standard Form Contract for RDG (PV + BESS)



**Maui
 Electric**

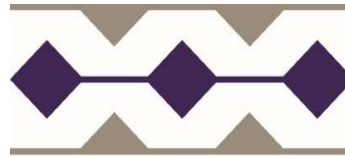

***MID-TIER STANDARD FORM CONTRACT
 for
 Renewable Dispatchable Generation
 (PV + BESS)
 September 8, 2020 Version***

This contract assumes that the proposed generation facility will be paired with a battery energy storage system ("BESS"), and therefore contains terms and conditions with respect to the BESS. If a generation only proposal is selected for the CBRE Mid-Tier Project RFP's final award group, the BESS specific provisions will be removed from this Contract for such project proposal.

Attachment A	Schedule Of Defined Terms
Attachment B	Company Payments for Energy, Dispatchability and Availability of Bess
Attachment C	Required Performance Metrics; Liquidated Damages
Attachment D	Calculation and Adjustment of Net Energy Potential
Attachment E	Monthly Reporting and Dispute Resolution by Independent AF Evaluator
Attachment F	Facility Owned by Subscriber Organization
Exhibit F-1	Description of Generation and Battery Storage Facilities
Exhibit F-2	Consultants List
Exhibit F-3	Modeling Requirements
Exhibit F-4	Generator and Energy Storage Capability Curve(S)
Exhibit F-5	Single-Line Drawing and Interface Block Diagram
Exhibit F-6	Relay List and Trip Scheme
Exhibit F-7	Control System Acceptance Test Criteria
Attachment G	Company-Owned Interconnection Facilities
Exhibit G-1	Form of Letter of Credit
Attachment H	BESS Requirements
Section 1	BESS Test
Section 2	BESS Annual Equivalent Availability Factor
Section 3	BESS Annual Equivalent Forced Outage Factor
Attachment I	Facility's CBRE Program

NOTE: THIS CONTRACT IS FOR PROJECTS THAT ARE AC-COUPLED. APPROPRIATE CHANGES WILL BE MADE FOR PROJECTS THAT ARE DC-COUPLED.

**MID-TIER STANDARD FORM CONTRACT
FOR
RENEWABLE DISPATCHABLE GENERATION**

THIS MID-TIER STANDARD FORM CONTRACT FOR RENEWABLE DISPATCHABLE GENERATION (“Contract”) is entered into as of _____, 20__ (the “Effective Date”), by [Maui Electric Company, Ltd., Hawai‘i Electric Light Company, Inc.], a Hawai‘i corporation (“Company”) and _____ (“Subscriber Organization”). Together, the Company and Subscriber Organization are the “Parties” and may singularly each be referred to as a “Party.”

RECITALS

WHEREAS, Company is an operating electric public utility engaged in the generation, transmission, distribution, storage, regulation, or physical control of electricity (“Company System”) on the Island of [Hawai‘i, Maui], subject to the Hawai‘i Public Utilities Law (Hawai‘i Revised Statutes, Chapter 269) and the rules and regulations of the Hawai‘i Public Utilities Commission (“PUC” or the “Commission”); and

WHEREAS, the Company System is operated as an independent power grid and must both maximize system reliability for its customers by ensuring that sufficient generation is available that meets the Company’s requirements for voltage stability, frequency stability, and reliability standards; and

WHEREAS, Company desires to minimize fluctuations in its purchased energy costs by acquiring renewable dispatchable generation at a fixed Unit Price; and

WHEREAS, Subscriber Organization understands the need to use all commercially reasonable efforts to maximize the overall reliability of the Company System; and

WHEREAS, Subscriber Organization is an approved “Subscriber Organization” for Phase 2 of the State of Hawai‘i Community-Based Renewable Energy (“CBRE”) Program, and desires to construct and operate a dispatchable generation renewable energy system (“CBRE Facility” or “Facility”) that is classified as an eligible resource under Hawai‘i’s Renewable Portfolio Standards Statute (codified as Hawai‘i Revised Statutes (HRS) 269-91 through 269-95) and qualifies for the CBRE Program together with a safe, reliable and operationally flexible battery energy storage system (“BESS”) so as to provide the Company System with those benefits and services associated with renewable energy generation and energy storage services, as defined herein; and

WHEREAS, this Contract applies to CBRE Facilities which provide at least 250 kW but less than 2.5 MW of renewable dispatchable generation and is entered into in accordance with the terms and conditions contained herein, the CBRE Tariff and Tariff Rule 14, Paragraph H (Interconnection of Distributed Generating Facilities Operating in Parallel With The Company’s Electric System) (“Rule 14H”); and

WHEREAS, the Parties agree to allow Subscriber Organization to interconnect and operate the CBRE Facility in parallel with the Company System so long as all applicable requirements and conditions of this Contract, the CBRE Tariff and Rule 14H have been satisfied; and

WHEREAS, the PV System to be developed by the Subscriber Organization will be a planned electrical energy generation system with a nameplate capacity of _____ kilowatts of alternating current (AC) (“PV System”); and

WHEREAS, the BESS to be installed by the Subscriber Organization will be an electrical energy battery storage system with a nameplate capacity in kilowatts of _____ and in kilowatt-hours [kWh] of _____; and

WHEREAS, the CBRE Facility will be installed and operated on property located at _____, Island of _____, State of Hawai'i and more fully described in Attachment F (Facility Owned by Subscriber Organization), Exhibit F-1 (Description of Generation and Battery Storage Facilities) to the Contract; and

WHEREAS, Subscriber Organization desires to sell to Company, and Company agrees to purchase, subject to the terms and conditions set forth herein, (i) the Actual Output produced by the Facility and delivered to the Point of Interconnection; (ii) the availability of the BESS; and (iii) the availability of the Facility's Net Energy Potential for Company Dispatch in accordance with this Contract;

NOW, THEREFORE, in consideration of the premises and the respective promises herein, Company and Subscriber Organization hereby agree as follows:

AGREEMENT

1. **DEFINITIONS.** Capitalized terms in this Contract shall have the meanings set forth in the Schedule of Defined Terms in Attachment A hereto.
2. **PARALLEL OPERATION.** Company agrees to allow Subscriber Organization to interconnect and operate the Facility to provide renewable dispatchable generation and energy in parallel with the Company System; provided, however, that such interconnection and operation shall not: (i) adversely affect Company's property or the operations of its customers and customers' property; (ii) present safety hazards to the Company System, Company's property or employees or Company's customers or the customers' property or employees; or (iii) otherwise fail to comply with this Contract. Such parallel operation shall be contingent upon the satisfactory completion, as determined solely by Company, of the Acceptance Test and, to the extent applicable, the Control System Acceptance Test, in accordance with Good Engineering and Operating Practices.
3. **TERM.**
 - A. The Term of this Contract shall begin when signed by the Parties and end twenty (20) years after the Commercial Operations Date unless otherwise provided for in this Contract.
 - B. This Contract shall continue in full force and effect as set forth above, until the earliest date that one of the following events occurs:
 1. The Parties agree in writing to terminate the Contract; or
 2. The Contract is declared null and void pursuant to the terms of Section 3.E (Contract Null and Void). Upon receipt of such notice, the Parties shall take reasonable steps to minimize additional costs to the other Party, where reasonably possible; or
 3. The Contract is terminated under Section 10.I.4 (Project Completion) if Subscriber Organization fails to interconnect and operate the CBRE Facility pursuant to the terms of this Contract or;
 4. The Contract is terminated pursuant to an Event of Default under the Contract.
 - C. Interconnection Requirements Study. If this Contract is executed prior to completion of the Interconnection Requirements Study, then following the completion of the IRS:
 1. The Parties shall, no later than the IRS Amendment Deadline, execute a formal amendment to this Contract substituting new versions of appropriate attachments to this Contract, including but not limited to, Attachment F (Facility Owned by Subscriber Organization) and Exhibits attached thereto, Attachment G (Company-Owned Interconnection Facilities) (the "IRS Amendment") solely to reflect the results of the IRS. If the IRS Amendment is not executed by the IRS Amendment Deadline, either Party may, by written notice delivered to the other Party, declare this Contract null and void.
 2. If Subscriber Organization is dissatisfied with the results of the IRS, Subscriber Organization shall have the option, by written notice delivered to Company no later than the IRS Termination Deadline, to declare the Contract null and void.

- D. Prior to IRS Amendment Deadline. Company may, by written notice delivered prior to the IRS Amendment Deadline, declare the Contract null and void if any one or more of the following conditions applies:
1. Subscriber Organization implements a material change to the Facility without following the requirements of Section 5(g) of Attachment F-1 (Description of Generation and Battery Storage Facilities).
 2. Subscriber Organization, subsequent to making any payment to Company required under Attachment G (Company-Owned Interconnection Facilities), or subsequent to making the payment to Company to pay for the IRS under the IRS Amendment(s), requests in writing that Company stop or otherwise delay the performance of the work for which Company received such payment.
 3. The IRS Letter Agreement(s) is/are terminated pursuant to the terms thereof prior to the completion of the IRS.
- E. Contract Null and Void. If the Contract is declared null and void pursuant to Section 3.C (Interconnection Requirements Study), Section 3.D (Prior to IRS Amendment Deadline), or Section 1(d) (NEP IE Estimate, Liquidated Damages and Subscriber Organization's Null and Void Right) of said Attachment D (Calculation and Adjustment of Net Energy Potential) (the "Null and Void Rights"), the Parties hereto shall thereafter be free of all obligations hereunder except as set forth in this Section 3.E (Contract Null and Void) and Section 11.F.2 (Return of Development Period Security), and shall pursue no further remedies against one another. A declaration that this Contract is null and void pursuant to the Null and Void Rights, shall not affect the following provisions, which shall remain in full force and effect: Section 26.A (Disconnection and Survival of Obligations), Section 26.L (Survival), this Section 3.E (Contract Null and Void), Section 8.F.2 (Confidentiality), Section 17 (Dispute Resolution), such provisions of Section 26 (Miscellaneous) which, by their terms, should survive termination of this Contract and Section 7 (Land Restoration) of Attachment G (Company-Owned Interconnection Facilities).
- F. Termination Rights. Notwithstanding any of the foregoing, the right of Company to terminate the Contract at any time upon the occurrence of any Event of Default described in Section 13 (Events of Default) shall remain in full force and effect.

4. BILLING AND PAYMENT PROVISIONS.

- A. Purchase and Sale of Renewable Energy, Dispatchability of CBRE Facility and Availability of the BESS. Subject to the other provisions of this Contract, Company shall, through a combination of Bill Credits allocated among CBRE Facility Subscribers and payments to Subscriber Organization, pay for: (i) the Actual Output produced by the CBRE Facility and delivered to the Point of Interconnection in response to Company Dispatch of the CBRE Facility; (ii) the availability of the CBRE Facility's Net Energy Potential for Company Dispatch in accordance with this Contract; and (iii) the availability of the BESS. Included in such purchase are all of the Environmental Credits associated with the renewable energy. Company will not reimburse Subscriber Organization for any taxes or fees imposed on Subscriber Organization including, but not limited to, State of Hawai'i general excise tax.
- B. Lump Sum Payment. Commencing on the Commercial Operations Date, Company shall pay a monthly lump sum payment ("Lump Sum Payment"), to be apportioned between Subscribed and Unsubscribed RDG, as provided in Section 2. (Lump Sum Payment for Purchase of Dispatchability) of Attachment B (Company Payments for Energy, Dispatchability and Availability of BESS) to this Contract. As more fully set forth in Section 3. (Calculation of Lump Sum Payment) of Attachment B, the monthly Lump Sum Payment shall be calculated and adjusted to reflect changes in the estimate of the CBRE Facility's Net Energy Potential as such estimate is revised from time to time as more fully set forth in Attachment D (Calculation and Adjustment of Net Energy Potential) to this Contract. For purposes of calculating the monthly Lump Sum Payment, the monthly Lump Sum Payment shall be adjusted downward to account for the time the PV System(s) are not available for Company Dispatch because of a Force Majeure condition (i) at the CBRE Facility, whether the PV System, the BESS or both, or (ii) that otherwise delays or prevents the Subscriber Organization from making the PV System(s) in question available for Company Dispatch, as more fully set forth in Section 3.D (Lump Sum Payment Pro-Rata Adjustments) of Attachment B (Company Payments for Energy, Dispatchability and Availability of BESS) to this Contract.

- C. Assurance of Capability of CBRE Facility to Deliver Net Energy Potential and Availability of BESS. In order to provide Company with reasonable assurance that, subject to the Renewable Resource Variability, the CBRE Facility's Net Energy Potential will be available for Company Dispatch: (i) the PV System Equivalent Availability Factor Performance Metric shall be used to evaluate the availability of the PV System for dispatch by Company; (ii) the Guaranteed Performance Ratio ("GPR") Performance Metric shall be used to evaluate the efficiency of the PV System; (iii) the BESS Capacity Performance Metric shall be used to confirm the capability of the BESS to discharge continuously for six (6) hours at Maximum Rated Output or to discharge continuously for a total energy (MWh) equal to the BESS Contract Capacity if the test is conducted at less than Maximum Rated Output; (iv) the BESS EAF Performance Metric shall be used to determine whether the BESS is meeting its expected availability; (v) the BESS EFOF Performance Metric shall be used to evaluate whether the BESS is experiencing excessive unplanned outages; and (vi) the RTE Performance Metric shall be used to evaluate the storage efficiency of the BESS. Whenever the PV System potential output is in excess of the Company Dispatch, the excess energy from the PV System shall be used to maximize the BESS State of Charge so long as this does not conflict with the operating parameters of the BESS set forth in Section 9.(d) (Battery Energy Storage System) of Attachment F (Facility Owned by Subscriber Organization) to this Contract. Subscriber Organization shall design, operate and maintain the CBRE Facility in a manner consistent with the standard of care reasonably expected of an experienced owner/operator with the desire and financial resources necessary to design, operate and maintain the CBRE Facility to achieve the Performance Metrics. The foregoing is without limitation to Subscriber Organization's other obligations under this Contract, including the obligation to operate the CBRE Facility in accordance with Good Engineering and Operating Practices. The Performance Metrics are set forth in Attachment C (Required Performance Metrics; Liquidated Damages) of this Contract and shall be interpreted consistent with the North American Electric Reliability Corporation Generating Availability Data System ("NERC GADS") Data Reporting Instructions. In the event of a conflict between NERC GADS and the terms of this Contract, the terms of this Contract will control.
- D. No Payments Prior to Commercial Operations Date. CBRE Facilities shall be subject to an Acceptance Test and a Control System Acceptance Test prior to initial parallel operation. Company may accept test energy delivered by Subscriber Organization as provided in Section 6. (Test Energy) of Attachment B (Company Payments for Energy, Dispatchability and Availability of BESS) to this Contract. The procedures for such tests will be provided to Subscriber Organization by the Company prior to executing this Contract. Company shall not compensate Subscriber Organization for such test energy.
- E. Sale of Energy to Third Parties. Subscriber Organization shall not sell the renewable energy produced, stored or associated with the CBRE Facility, to any person or entity other than the Company during the Term of this Contract.
- F. Subscriber Organization's Preparation of the Monthly Invoice. By the tenth (10th) Business Day of each calendar month, Subscriber Organization shall submit to Company an invoice that separately states the following for the preceding calendar month: (i) the Actual Output during the preceding calendar month; (ii) the monthly Lump Sum Payment for the preceding calendar month; (iii) a computation, based on the updated Monthly Subscriber Information for such preceding calendar month as provided pursuant to Section 4. (Updating Monthly Subscriber Information Used to Calculate Bill Credits and Other Matters) of Attachment B (Company Payments for Energy, Dispatchability and Availability of BESS) to this Contract, of each Subscriber's Subscriber Allocation for the preceding month stated as a percentage of Contract Capacity; (iv) the Unsubscribed RDG for the preceding calendar month stated as a percentage of Contract Capacity; (v) a computation, based on each Subscriber's Subscriber Allocation, of the dollar amount of the Bill Credit to which each Subscriber is entitled for the monthly Lump Sum Payment for the preceding calendar month; (vi) the dollar amount owing to Subscriber Organization for its share of the monthly Lump Sum Payment for the preceding calendar month; and (vii) as a credit against the amount owing to the Subscriber Organization, the amounts payable by Subscriber Organization under Section 8.D (Subscriber Organization Fees) of this Contract. The dollar amount payable to the Subscriber Organization shall be subject to adjustment as provided in Section 5. (Adjusting Payment to Subscriber Organization; Liquidated Damages) of Attachment B (Company Payments for Energy, Dispatchability and Availability of BESS) to this Contract.

G. Payment Procedures.

1. Payments to Subscriber Organization. By the twentieth (20th) Business Day of each calendar month following the month during which the invoice was submitted (i.e., by the twentieth (20th) Business Day of the second calendar month following the calendar month covered by the invoice in question), and not later than the last Business Day of that month if there are less than twenty (20) Business Days in that month, Company shall, make payment to Subscriber Organization of the amount payable for the Unsubscribed RDG shown on such invoice, or provide to Subscriber Organization an itemized statement of its objections to all or any portion of such invoice and pay Subscriber Organization its share of any undisputed amount. Any such payment to the Subscriber Organization shall be subject to adjustment as provided in Section 5. (Adjusting Payment to Subscriber Organization; Liquidated Damages) of Attachment B (Company Payments for Energy, Dispatchability and Availability of BESS) to this Contract, and shall also be subject to Company's right to set-off liquidated damages as provided in Section 8. (Payment of Liquidated Damages for Failure to Achieve Performance Metrics; Limitation on Liquidated Damages) of Attachment C (Required Performance Metrics; Liquidated Damages) to this Contract.
2. Time Extensions. Notwithstanding the foregoing, the Day by which the Company shall make payment to Subscriber Organization hereunder shall be increased by one (1) Day for each Day that Subscriber Organization is delinquent in providing to the Company either: (i) the Monthly Report for the calendar month in question pursuant to Section 1. (Monthly Report) of Attachment E (Monthly Reporting and Dispute Resolution by Independent AF Evaluator) to this Contract; or (ii) the information required under Section 4.F (Subscriber Organization's Preparation of the Monthly Invoice) of this Contract.

H. Bill Credits.

1. The sole means of payment for each Subscriber Allocation for the calendar month covered by the invoice shall be by a Bill Credit on such Subscriber's retail electric bill. The Bill Credit shall be calculated on the undisputed amount of Subscriber Organization's invoice as set forth in Section 4.F. (Subscriber Organization's Preparation of the Monthly Invoice) of this Contract. Because not all of Company's customers have the same billing cycle, the timing of the appearance of the Bill Credit will vary with the Subscriber's billing cycle, but Company shall cause the Bill Credit to appear on each Subscriber's retail electric bill no later than the next billing cycle for such Subscriber following the due date for Company's payment to Subscriber Organization for the Unsubscribed RDG on the corresponding invoice. The calendar month upon which the Bill Credit is based shall not necessarily match the billing period for the retail electric service bill in which the Bill Credit is applied.
 2. For purposes of applying the Bill Credit to each Subscriber's retail electric bill, the Company shall be entitled to rely exclusively on the Monthly Subscription Information as timely entered by the Subscriber Organization via the CBRE Online Portal as set forth in Section 4. (Updating Monthly Subscriber Information Used to Calculate Bill Credits and Other Matters) of Attachment B (Company Payments for Energy, Dispatchability and Availability of BESS) to this Contract.
 3. If there is a breach, error or changed circumstances resulting in some portion of the monthly Lump Sum Payment being assigned to a Subscriber in excess of such Subscriber's allowable Subscriber Allocation under the CBRE Tariff, then the Company may treat this excess as an "overpayment" of the Subscriber Allocation and reduce the Bill Credit(s) to such Subscriber for the following calendar month for overpayment in proportion to the excess allocation received in error. Payment to the Subscriber Organization for such Unsubscribed RDG shall only occur if no corresponding Bill Credit is made to a Subscriber, or if already allocated, if such allocation is corrected and withdrawn from such Subscriber. The intent of the Parties is to ensure that no production from the CBRE Facility is double-counted to any Subscriber and/or Subscriber Organization.
- I. Late Payments. Notwithstanding all or any portion of such invoice in dispute, and subject to the provisions of Section 8. (Payment of Liquidated Damages for Failure to Achieve Performance Metrics; Limitation on Liquidated Damage) of Attachment C (Required Performance Metrics; Liquidated Damages) to this Contract (to the extent applicable), interest shall accrue on any invoiced amount that remains unpaid following the twentieth (20th) Business Day of each calendar month (or the last Business Day of that month if there are less

than twenty Business Days in that month), or following the due date for such payment if extended pursuant to Section 4.G.2. (Time Extensions) to this Contract, at the average daily Prime Rate for the period commencing on the Day following the Day such payment is due until the invoiced amounts (or amounts due to Subscriber Organization if determined to be less than the invoiced amounts) are paid in full. Partial payments shall be applied first to outstanding interest and then to outstanding invoice amounts.

- J. Adjustments to Invoices after Payment. In the event adjustments are required to correct inaccuracies in an invoice after payment, the Party requesting adjustment shall recompute and include in the Party's request the principal amounts due during the period of the inaccuracy together with the amount of interest from the date that such invoice was payable until the date that such recomputed amount is paid at the average daily Prime Rate for the period. The difference between the amount paid and that recomputed for the invoice, along with the allowable amount of interest, shall either be (i) paid to Subscriber Organization or set-off by Company, as appropriate, in the next invoice payment to Subscriber Organization, or (ii) objected to by the Party responsible for such payment within thirty (30) Days following its receipt of such request. If the Party responsible for such payment objects to the request, then the Parties shall work together in good faith to resolve the objection. If the Parties are unable to resolve the objection, the matter shall be resolved pursuant to Section 17. (Dispute Resolution) of the Contract. All claims for adjustments shall be waived for any amounts that were paid or should have been payable more than thirty-six (36) months preceding the date of receipt of any such request.
- K. Limitations Period. All Subscriber Organization claims for adjustments shall be submitted to the Company within three years of the end of the calendar month covered by the invoice on which the adjustment amount in question was invoiced or should have been invoiced. Claims not submitted to the Company by the end of such three-year period shall be deemed to have been waived.
- L. Company's Billing Records. Subscriber Organization, after giving reasonable advance written notice to Company, shall have the right during Company's normal working hours on Business Days to review all billing, metering and related records necessary to verify the accuracy of the data provided by Company regarding payments and credits.
- M. Subscriber Organization Responsibility for Billing Inaccuracies. The correction of any allocation of previously-applied Bill Credits among Subscribers or payments to the Subscriber Organization for Unsubscribed RDG, pertaining to a particular month due to any inaccuracy reflected in such Monthly Subscription Information with regard to a Subscriber's subscription in the CBRE Facility and the beneficial share of (RDG / NEP) exported by the CBRE Facility, or the share of Unsubscribed RDG, shall be the full responsibility of the Subscriber Organization, unless such inaccuracies are shown to have been caused by the Company.

5. COMPANY DISPATCH.

- A. General. Company shall have the right to dispatch all available real and reactive power delivered from the CBRE Facility to the Company System and to start up and shut down Subscriber Organization's generating units, as it deems appropriate in its reasonable discretion, subject only to Company Dispatch and Subscriber Organization's operations and maintenance schedule determined in accordance with Section 4. (Maintenance of Subscriber Organization-Owned Interconnection Facilities) and Section 10. (Operations Committee and Operating Procedures) to Attachment F (Facility Owned by Subscriber Organization) to this Contract. Because the CBRE Facility must be available to respond to Company Dispatch, the Facility may not consume any energy generated by the Facility. Company shall not pay for reactive power.
- B. Company Dispatch. Dispatch will either be by Subscriber Organization's manual control under the direction of the Company System Operator or by remote computerized control by the EMS provided in Section 1.(g) (Active Power Control Interface) of Attachment F (Facility Owned by Subscriber Organization) to this Contract, in each case at Company's reasonable discretion.
- C. Company Rights of Dispatch. Company may require deration or outage in response to the CBRE Facility's failure to comply with Company Dispatch or to any conditions of Subscriber Organization-Attributable Non-Generation. A deration or outage required by Company pursuant to the preceding sentence shall be considered a Planned Deration and shall "count against" Subscriber Organization for the purpose of

calculating the PV System Equivalent Availability Factor until the conditions that led to the deration or outage are resolved by Subscriber Organization and Subscriber Organization notifies Company of same. If, after such communication, Company attempts to dispatch the CBRE Facility and determines that such conditions that led to the deration or outage are not resolved, all time from the notice of resolution to actual resolution shall be revised as continuance of the deration or outage. If Subscriber Organization requests confirmation from Company that Subscriber Organization's actions to resolve such conditions that led to the deration or outage were successfully completed, then Company shall use reasonable efforts to respond to such request within three (3) Business Days in writing (with email being acceptable) to allow Subscriber Organization the opportunity to take further appropriate corrective actions if needed. An outage or deration required by Company pursuant to the first sentence of this sub-section shall not be considered a "restriction or limitation that would lower maximum output" of the CBRE Facility for purposes of filtering the 15-minute intervals used to calculate the MPR under Section 2.A. (Calculation of Measured Performance Ratio) of Attachment C (Required Performance Metrics; Liquidated Damages) to this Contract and shall, therefore, potentially "count against" Subscriber Organization for purposes of calculating MPR until the conditions that led to such outage or deration are resolved by Subscriber Organization to Company's reasonable satisfaction. Nothing in this sub-section shall relieve Subscriber Organization of its obligation under the terms of this Contract to make available the full capability of the CBRE Facility for Company Dispatch.

- D. Monthly Report. Commencing with the month during which the Commercial Operations Date is achieved, and for each calendar month thereafter during the Term, Subscriber Organization shall prepare and provide to Company a Monthly Report by the tenth (10th) Business Day of the following month in accordance with Attachment E (Monthly Reporting and Dispute Resolution by Independent AF Evaluator) to this Contract. Beginning with the Monthly Report for the last calendar month of the initial Contract Year, Subscriber Organization shall include calculations of, as applicable, (a) the PV System Equivalent Availability Factor for the LD Period, (b) the Measured Performance Ratio for the MPR Assessment Period, (c) any of the BESS Capacity Ratio, the BESS Annual Equivalent Availability Factor, the BESS Equivalent Forced Outage Factor or the RTE Performance Metric for the BESS Measurement Period (if any), as well as (d) any liquidated damages to be assessed, as set forth in the form of Monthly Report included in Attachment E (Monthly Reporting and Dispute Resolution by Independent AF Evaluator). All rights and obligations of the Parties with respect to each Monthly Report and any disagreements arising out of any Monthly Report are fully set forth in Attachment E (Monthly Reporting and Dispute Resolution by Independent AF Evaluator) to this Contract.

6. **HOUSE POWER.** The Company will sell House Power to the CBRE Facility under the rate schedule in force for the class of customer to which the Subscriber Organization belongs. A separate meter to record energy delivered to the CBRE Facility may be installed by the Company. The Subscriber Organization shall be solely responsible for arranging retail electric service exclusively from the Company in accordance with the Company's Electric Rate Book. The Subscriber Organization shall obtain House Power solely through separately metered retail service and shall not obtain House Power through any other means and waives any regulatory or other legal claim or right to the contrary. Because the Subscriber Organization must make all energy produced by the CBRE Facility available to the Company, the CBRE Facility may not use the energy it generates to be consumed by it. It may not net-out or use energy it generates for House Power. The Parties acknowledge and agree that the performance of their respective obligations with respect to House Power shall be separate from this Contract and shall be interpreted independently of the Parties' respective obligations under this Contract. Notwithstanding any other provision in this Contract, nothing with respect to the arrangements for House Power shall alter or modify the Subscriber Organization's or the Company's rights, duties and obligations under this Contract. This Contract shall not be construed to create any rights between the Subscriber Organization and the Company with respect to the arrangements for House Power.

7. **METERING REQUIREMENTS, CHARGES AND TESTING.**

- A. Company shall install, operate and maintain for the benefit of the CBRE Facility, one or more revenue metering package(s) suitable for measuring the export of renewable energy (AC) produced by the CBRE

Facility in kilowatts and kilowatt-hours on a time-of-day basis and reactive power flow in kilovars and true root mean square kilovar-hours (the "Revenue Meter"). The metering point for the Revenue Meter shall be as close as possible to the Point of Interconnection as allowed by Company.

- B. Subscriber Organization, subject to Company review and approval, shall purchase, install, and maintain the infrastructure and other related equipment ("Meter Infrastructure") including meter housing, socket replacement and rewiring as required to install the Revenue Meter and any additional service meter(s), including, but not limited to, such meters for measuring House Power. Subscriber Organization shall install the Meter Infrastructure in adherence with requirements set forth in the latest edition of the Company's Electric Service Installation Manual (ESIM). Company shall test the Production Meter prior to installation and at the request and expense of the Subscriber Organization.
- C. Subscriber Organization shall reimburse Company for the costs reasonably incurred for the purchase and installation of the Revenue Meter. Subscriber Organization shall be responsible for the ongoing costs incurred by Company to operate, maintain (including maintenance replacements) and test the Revenue Meter during the Term.
- D. Metering Charge per Month: \$25.00. Subscriber Organization shall be charged each month during the Term an administrative metering fee of a \$25.00 for the Revenue Meter. The administrative metering fee is addition to the costs associated with the purchase, installation, maintenance and testing of the Revenue Meter and Meter Infrastructure.
- E. Meter Testing. Company shall provide at least forty-eight (48) hours' notice to Subscriber Organization prior to any test it may perform on the Revenue Meter or metering equipment. Subscriber Organization may request tests in addition to the every fifth-year test and Subscriber Organization shall pay the cost of such tests. Company may perform tests in addition to the fifth-year test. If any of the revenue meters or metering equipment is found to be inaccurate at any time, as determined by testing in accordance with this section, Company shall promptly cause such equipment to be made accurate, and the period of inaccuracy, as well as an estimate for correct meter readings, shall be determined as provided in Company's Tariff Rule No.11 (Billing Error, Meter Tests and Adjustment for Meter Errors).

8. CBRE TARIFF REQUIREMENTS.

- A. CBRE Framework and CBRE Tariff. The Subscriber Organization shall comply with and assure that the requirements of the CBRE Framework and CBRE Tariff applicable to the CBRE Facility are met.
- B. Subscriber Agreement. Subscriber Organization shall require all prospective Subscribers to execute a Subscriber Agreement as a precondition to enrollment as a Subscriber in the CBRE Facility. The Subscriber Agreement must satisfy the requirements of the CBRE Tariff, the CBRE Framework, this Contract and any additional guidance from the PUC. Without limitation to the generality of the preceding sentence, the Subscriber Agreement must include the right for the Subscriber to sell the subscription, either a portion or the entirety thereof, back to Subscriber Organization. The Subscriber Agreement shall require that the Subscriber Organization must buy back the interest in accordance with the preset repurchase/resale price schedule outlined in the Subscriber Agreement within thirty (30) Days of the Subscriber's request. Prior to executing the Subscriber Agreement, the Subscriber Organization shall make to the Subscriber the disclosures required under the Disclosure Checklist (attached as an Appendix to the CBRE Tariff). A copy of the Disclosure Checklist signed by both the Subscriber Organization and the Subscriber shall be attached to the executed Subscriber Agreement. The Subscriber Organization shall also disclose to the Subscriber that a failure to pay such Subscriber's monthly retail electric bill that results in Company issuance of a disconnection notice will result in forfeiture of Bill Credits for the duration of such disconnection. For each Subscriber, there must be a completed and fully executed Subscriber Agency Agreement and Consent Form (attached as an Appendix to the CBRE Tariff), which is delivered to the Company prior to the Commercial Operations Date, or prior to adding each Subscriber. The Subscriber Organization shall provide to each Subscriber a copy of the Subscriber's Bill of Rights (attached as an Appendix to the CBRE Tariff).
- C. Funds Received From Subscribers Prior to the Commercial Operations Date. Any payments made to Subscriber Organization by Subscribers prior to the Commercial Operations Date shall be deposited into an escrow account or other alternative proposed by Subscriber Organization and approved by the Company or

CBRE IO ("Pre-COD Escrow"), to hold or segregate any pre-development enrollment fees or deposits from Subscribers (with appropriate mechanisms to refund such fees/deposits to Subscribers should the Subscriber Organization not complete its Facility), which shall be released to Subscriber Organization upon commercial operation of the Facility. These funds may not be withdrawn from the Pre-COD Escrow by the Subscriber Organization until the Commercial Operations Date. The Pre-COD Escrow must conform to the CBRE Tariff, the CBRE Framework, applicable Laws, and any additional guidance from the PUC.

D. Subscriber Organization Fees.

1. Subscriber Organization shall pay to Company the following fees:
 - \$250 Application Fee (once);
 - All applicable late fees for failure to meet Commercial Operations Date;
 - \$5/kW AC Program Administration Fee (annually), from the Commercial Operations Date;
 - \$25.00 (monthly) Revenue Meter Administration Fee;
 - Such other fees as the PUC may establish for the CBRE Program.
2. If Company does not set off the amount of these fees against Company payments to Subscriber Organization for Unsubscribed Energy, Company may, in its sole discretion, obtain payment from Security Funds, or invoice Subscriber Organization for payment to Company of the foregoing fees. Subscriber Organization shall make payment to Company within fifteen (15) Days of Subscriber Organization's receipt of such invoice.

E. Facility Compliance.

1. The Subscriber Organization shall be responsible for ensuring that the equipment installed at the CBRE Facility meets all applicable codes, standards, and regulatory requirements at the time of installation and throughout its operation.
2. Subscriber Organization shall comply with all of the rules stated in the Company's applicable electric tariff rules related to the CBRE Program, as the same may be revised from time to time, and this Contract, as may be amended from time to time, as allowed by an amendment to this Contract approved, or deemed approved, by the PUC. In the event of any conflict between the terms of this Contract and Company's electric tariff rules related to the CBRE Program, the provisions of the tariff shall control.

F. Financial Compliance.

1. If Company reasonably believes the provisions of this Section 8.F apply to the CBRE Facility, Company shall notify Subscriber Organization in writing and Subscriber Organization shall provide or cause to be provided to Company on a timely basis, all information, including but not limited to information that may be obtained in any audit referred to below (the "Financial Compliance Information"), reasonably requested by Company for purposes of permitting Company and its parent company, Hawaiian Electric Industries, Inc. ("HEI") to comply with the requirements (initial and on-going) of (i) the accounting principles of Financial Accounting Standards Board ("FASB") Accounting Standards Codification 810, Consolidation ("FASB ASC 810"), (ii) FASB ASV 842 Leases ("FASB ASC 842"), (iii) Section 404 of the Sarbanes-Oxley Act of 2002 ("SOX 404") and (iv) all clarifications, interpretations and revisions of and regulations implementing FASB ASC 810, FASB ASC 842, and SOX 404 issued by the FASB, Securities and Exchange Commission, the Public Company Accounting Oversight Board, Emerging Issues Task Force or other Governmental Authorities. In addition, if required by Company in order to meet its compliance obligations, Subscriber Organization shall allow Company or its independent auditor to audit, to the extent reasonably required, Subscriber Organization's financial records, including its system of internal controls over financial reporting; provided, however, that Company shall be responsible for all costs associated with the foregoing, including but not limited to Subscriber Organization's reasonable internal costs. Company shall limit access to such Financial Compliance Information to Company and HEI personnel involved with such compliance matters and restrict any Company or HEI personnel involved in Company's monitoring, dispatch or scheduling of the Subscriber Organization and/or the CBRE Facility, the administration of this Contract, or in developing potential CBRE projects, from having access to such Financial Compliance Information (unless approved in writing in advance by Subscriber Organization).

2. Confidentiality. As a condition to obtaining the Financial Compliance Information, Company shall, and shall cause HEI to, maintain the confidentiality of said Financial Compliance Information pursuant to a mutually agreed to confidentiality and non-disclosure agreement to be executed among Company, HEI and Subscriber Organization.
 3. Consolidation. Company does not want to be subject to consolidation as set forth in FASB ASC 810, as issued and amended from time to time by FASB. Company represents that, as of the Effective Date, it is not required to consolidate Subscriber Organization into its financial statements in accordance with FASB ASC 810. If for any reason, at any time during the Term, Company determines, in its sole but good faith discretion, that it is required to consolidate Subscriber Organization into its financial statements in accordance with FASB ASC 810, then Subscriber Organization shall immediately provide audited financial statements (including footnotes) in accordance with U.S. generally accepted accounting principles (and as of the reporting periods Company is required to report thereafter) in order for Company to consolidate and file its financial statements within the reporting deadlines of the Securities and Exchange Commission. Notwithstanding the foregoing requirement that Subscriber Organization provide audited financial statements to Company, the Parties will take all commercially reasonable steps, which may include modification of this Contract to eliminate the consolidation treatment, while preserving the economic "benefit of the bargain" to both Parties.
- G. Audits. The Company reserves the right to inspect the CBRE Facility as necessary to assure the safety and reliability of the system at any time during the Term, and for an additional period of one (1) year thereafter.

9. **REQUIREMENTS APPLICABLE TO SUBSCRIBER ORGANIZATION'S RELATIONSHIP WITH ITS SUBSCRIBERS.** The Subscriber Organization must comply with all of the following:

- A. Subscriber Information. The Subscriber Organization shall issue subscriptions in the CBRE Facility only to eligible retail electric service customers of the Company and provide to the Company the name, account number and service address attributable to each subscription and the Subscriber Allocation for each Subscriber's subscription. The Subscriber Organization shall take care to preserve the privacy expectations of the Subscribers, such as not publicly providing a Subscriber's Confidential Account Information, Subscriber Energy Usage Data, or Bill Credits. The Subscriber Organization will not disclose or share such information except as permitted by the Subscriber Agency Agreement and Consent Form executed by Subscriber in connection with Subscriber's acquisition of its subscription in the CBRE Facility or otherwise unless the Subscriber has provided explicit informed consent or if such disclosure is compelled by Law.
- B. Subscriber Exit or Transfer of Interest in CBRE Facility. The transfer, cancellation, termination and/or exit of a Subscriber's interest in the CBRE Facility shall be completed in full accordance with applicable CBRE Framework or CBRE Tariff rules, in addition to any other terms, conditions or requirements imposed by the Subscriber Organization in the Subscriber Agreement, which Subscriber Organization shall ensure is also consistent with and in compliance with applicable CBRE Framework or CBRE Tariff rules. The CBRE Framework and/or CBRE Tariff requirements shall take precedence over any inconsistent or conflicting provisions found in the Subscriber Agreement.
- C. Updating Subscriber Information. The Subscriber Organization shall provide to the Company the Monthly Subscriber Information together with any and all updates to the Monthly Subscription Information as provided in Section 4. (Updating Monthly Subscriber Information Used to Calculate Bill Credits and Other Matters) to Attachment B (Company Payments for Energy, Dispatchability and Availability of Bess) to this Contract.
- D. Responsibility for Verification.
 1. Subscriber Verification. If not already qualified by the CBRE Online Portal, the Subscriber Organization shall verify that each Subscriber is eligible to be a Subscriber in the CBRE Facility and that the CBRE Tariff requirements are met.
 2. LMI Subscriber Verification. For CBRE LMI Projects (as defined in the CBRE Tariff) or for CBRE Mid-Tier Projects or CBRE Large Projects (as defined in the CBRE Tariff) which commit to a certain percentage of LMI Subscribers, in addition to the requirements of Section 9.D.1., Subscriber Organization must comply with CBRE Tariff provisions to verify the LMI status of each LMI Subscriber.

- E. Disclosure of Production Information. The Subscriber Organization acknowledges and agrees that, in order for the Company to carry out its responsibilities in applying Bill Credits to each Subscriber's retail electric bills, the Company may be required and shall be permitted to provide access or otherwise disclose and release to any Subscriber any and all production data related to the PV System and BESS in its possession and information regarding the total Bill Credits applied by the Company with respect to the CBRE Facility and any information pertaining to a Subscriber's subscription. Any additional detailed information requested by a Subscriber shall be provided only upon the Subscriber Organization's consent in writing or email to the Company, or unless the Commission or the CBRE IO requests that the Company provide such information to the Subscriber, or as otherwise required by law.
- F. Disclosure of CBRE Facility Information. The Subscriber Organization acknowledges and agrees that the Company may publicly disclose the CBRE Facility location, Subscriber Organization, nameplate capacity and production data of the CBRE Facility. Additionally, the Company will periodically provide a bill message to Subscribers clarifying that questions or concerns related to their subscription should be directed to the Subscriber Organization, including a statement that the Subscriber Organization is solely responsible for resolving any disputes with the Company or the Subscriber about the accuracy of the CBRE Facility data and that the Company is solely responsible for resolving any disputes with the Subscriber about the applicable rate used to determine the amount of the Bill Credit.
- G. Certain Tax and Securities Law Issues. The Company makes no warranty or representation concerning the taxable consequences, if any, to Subscriber Organization or its Subscribers with respect to its Bill Credits to the Subscribers for participation in the CBRE Facility. Additionally, the Company makes no warranty or representation concerning the implication of any federal or state securities laws on how subscriptions to the CBRE Facility are handled.
- H. Full Cooperation with the PUC. The Parties agree to fully cooperate with any request for information from the PUC or the CBRE IO pertaining in any way to the CBRE Facility and will provide such information upon request in a timely manner. To the extent to which any request calls for producing a specific Subscriber's Confidential Account Information, Subscriber Energy Usage Data or Bill Credits, such information shall be provided and marked as Confidential Information.
- I. New Energy Generating Systems. The PV System must not be built or previously interconnected at the time of application to the CBRE Program.
- J. Fair Disclosure; Disclosure Checklist. Prior to the time when any person or entity becomes a Subscriber, the Subscriber Organization will fairly disclose the future costs and benefits of the subscription and all other matters specified in the Disclosure Checklist and provide to the potential Subscriber a copy of this Contract. The Subscriber Organization shall comply with all other requirements of the PUC and applicable Laws with respect to communications with Subscribers.

10. GENERAL PROVISIONS FOR CBRE FACILITY DESIGN, CONSTRUCTION AND OPERATION.

- A. The following provisions generally set forth the minimum requirements of Subscriber Organization in designing, constructing and operating the CBRE Facility and are more fully described in Attachment F (Facility Owned by Subscriber Organization) and including without limitation the exhibits to Attachment F, Exhibits F-1 through F-6. In the event of any inconsistency or conflict between the terms and provisions of this Section 10, the terms and provisions of Attachment F and Exhibits F1-F6 shall control.
- B. Permits and Licenses. Subscriber Organization shall be responsible for the design, installation, operation, and maintenance of the CBRE Facility and shall obtain at its expense and maintain any required governmental authorizations and/or permits for the construction and operation of the CBRE Facility.
- C. Control and Protection of Equipment. Design, installation, operation and maintenance of the CBRE Facility shall include control and protection equipment as specified by the Company, including but not limited to an automatic load-break device such as a circuit breaker or inverter and a manual disconnect that has a visible break or breaker with rack-out capability to isolate the CBRE Facility from the Company System. The manual disconnect device must be accessible by the Company and be capable of being locked by the Company in the open position, to establish working clearance for maintenance and repair work in accordance with the Company's safety rules and practices. The disconnect devices shall be furnished and installed by the

Subscriber Organization and are to be connected between the CBRE Facility and the Company system. The disconnect devices shall be located in the immediate vicinity of the electric meter serving the Subscriber Organization. The manual disconnect device shall be, at a minimum, clearly labeled "Subscriber Organization System Disconnect." With permission of the Company, the disconnect devices may be located at an alternate location which is readily and safely accessible to the Company on a 24-hour basis. Such alternate location shall be clearly identified with signage placed in the immediate vicinity of the electric meter serving the Subscriber Organization.

- D. Access. The Subscriber Organization grants access to the Company to utilize the disconnect device, if needed. Subscriber Organization shall obtain the authorization from the owner and/or occupants of the premises where the CBRE Facility is located that allows the Company to access the CBRE Facility for the purpose specified in this Contract. Company may enter premises where the CBRE Facility is located, as permitted by law or tariff, for the following purposes: (1) to inspect CBRE Facility's protective devices and read or test meter(s); and (2) to disconnect the CBRE Facility and/or service to Subscriber Organization, whenever in Company's sole opinion, a hazardous condition exists and such immediate action is necessary to protect persons, Company's facilities, or property of others from damage or interference caused by the CBRE Facility, or the absence or failure of properly operating protective device.
- E. Prior Written Approval. Under no circumstances shall a Subscriber Organization interconnect and operate the CBRE Facility in parallel with the Company's electric system without prior written approval by the Company.
- F. Equipment Modifications. Once the CBRE Facility is interconnected to the Company's system, the Company reserves the right to require the installation of, or modifications to, equipment determined by the utility to be necessary to facilitate the delivery of reliable electric service to its customers, subject to the requirement that such installation or modification be consistent with applicable interconnection standards (e.g., Rule 14H). The Company shall provide a written explanation of the need for such installation or modification. Any disputes related to this provision shall be resolved according to the dispute resolution process set forth in Section 17. (Dispute Resolution) of this Contract.
- G. [RESERVED]
- H. Telemetry and Control Interface. The CBRE Facility must comply with the communications and controllability requirements set forth in Section 1.(b) (Certain Specifications for the Facility), Sub-section (iii).e. of Attachment F (Facility Owned by Subscriber Organization) to this Contract.
- I. Project Completion.
1. The Subscriber Organization shall achieve the Commercial Operations Date for the CBRE Facility within eighteen (18) months from the execution date of this Contract, as the same may be extended as provided herein or in the CBRE Tariff (the "Commercial Operations Date Deadline"). The Commercial Operations Date Deadline shall be extended day-for-day for a CBRE Facility that, in the Company's determination, has suffered a Force Majeure event as set forth in Section 27. (Force Majeure) of this Contract prior to the Commercial Operations Date, or for any delay caused by Company.
 2. Notwithstanding the foregoing, a local-government moratorium to issuing a permit may extend the 18-month Project Completion period for no more than an additional six (6) months. Failure to seek a permit, delay in seeking a permit, or permit-processing time not subject to a moratorium is not included in this 6-month extension.
 3. If Substantial Progress, as defined herein, has been achieved, but the Commercial Operations Date has not been achieved by the Commercial Operations Date Deadline, and Subscriber Organization still intends to complete its CBRE Facility, then the Subscriber Organization shall pay a "late fee" to Company of \$200/day/MW nameplate capacity of the PV System until the CBRE Facility achieves the Commercial Operations Date. For example, if the CBRE Facility has a nameplate capacity of 500 kW, and it achieves the Commercial Operations Date thirty (30) Days late, the "late fee" would be \$3,000. The "late fee" shall be paid to Company before the Commercial Operations Date. However, if Company fails to collect in full such amount by this date, such unpaid amount may be set off against any refund that may be due to Subscriber Organization for Total Estimated Interconnection Costs paid by Subscriber Organization that exceeds the Actual Interconnection Costs. All "late fee" payments received by Company will be credited back through the appropriate regulatory mechanism to offset the costs to Company ratepayers for the

CBRE Program. A prerequisite to showing that Substantial Progress has been achieved in a timely manner is that before the Commercial Operations Date Deadline the Subscriber Organization must submit a signed letter to Company attesting to the fact that Substantial Progress as defined in this Contract has been made, and attach photographs to that letter demonstrating this.

4. If: (i) Substantial Progress has not been achieved by the Commercial Operations Date Deadline, or (ii) Subscriber Organization does not wish to complete its CBRE Facility upon the Commercial Operations Date Deadline, or (iii) the Commercial Operations Date that is extended due to a permit issuance moratorium is not achieved within six (6) months from the originally required Commercial Operations Date Deadline, then the application for the CBRE Facility and this Contract will be terminated by Company without further notice. No additional concurrence from the CBRE IO shall be necessary for such termination. The Application Fee and any other deposits paid by the Subscriber Organization shall be forfeited.
5. After termination, the Subscriber Organization, if it still intends to proceed with the CBRE Facility, must submit a new application and pay any applicable deposit and/or fees which will be subject to the then current CBRE Tariff, Bill Credit Rate and other applicable CBRE requirements for new projects, including CBRE Program capacity availability.

11. INTERCONNECTION REQUIREMENTS.

- A. Rule 14H Compliance. The Subscriber Organization must comply with all of the terms, conditions and requirements of Rule 14H (Interconnection of Distributed Generating Facilities Operating in Parallel With The Company's Electric System), including without limitation Appendix I (Distributed Generation Facility Interconnection Standards Technical Requirements). In the event of any inconsistency or conflict between the terms and provisions of this Contract and Rule 14H, the terms and provisions of Rule 14H shall control.
- B. Distribution Interconnection. If the CBRE Facility is a facility interconnecting at the Distribution level, the CBRE Facility shall follow the applicable Rule No. 14H interconnection process at the time of interconnection. If the CBRE Facility is a facility interconnecting at the Sub-Transmission and Transmission levels, the CBRE Facility shall follow the interconnection process applicable to such CBRE Facility at the time of interconnection.
- C. Subscriber Organization-Owned Interconnection Facilities.
 1. The Subscriber Organization shall furnish, install, operate and maintain, at its cost, the interconnection facilities (such as circuit breakers, relays, switches, synchronizing equipment, monitoring equipment, and control and protective devices and schemes identified in Exhibit F-1 (Description of Generation and Battery Storage Facilities) of Attachment F (Facility Owned by Subscriber Organization) to this Contract.
 2. The point of interconnection is shown on the single-line diagram and three-line diagram (provided by the Subscriber Organization and reviewed by the Company) which are appended to Attachment F, herein. Pursuant to Rule 14H, Appendix I (Distributed Generation Facility Interconnection Standards Technical Requirements), Section 6.c (Review of Design Drawings), the Company must review and approve Subscriber Organization's single-line and three-line diagrams prior to Subscriber Organization constructing of the CBRE Facility interconnection.
 3. The Subscriber Organization shall not operate equipment that superimposes a voltage or current upon the Company's system that interferes with the Company's operations, service to the Company's customers, or the Company's communication facilities. Such interference shall include, but not be limited to, overcurrent, voltage imbalance, and abnormal waveforms. If such interference occurs, the Subscriber Organization must diligently pursue and take corrective action at its own expense after being given notice and reasonable time to do so by the Company. If the Subscriber Organization does not take timely corrective action or continues to operate the equipment causing interference without restriction or limit, the Company may, without liability, disconnect the Subscriber Organization's equipment from the Company's system. Pursuant to Rule 14H, Appendix I (Distributed Generation Facility Interconnection Standards Technical Requirements), Section 6.c (Review of Design Drawings), the Company must review and approve Subscriber Organization's single-line and three-line diagrams prior to Subscriber Organization constructing of the CBRE Facility interconnection.

4. The Subscriber Organization agrees to test the CBRE Facility, to maintain operating records, and to follow such operating procedures, as may be specified by the Company to protect the Company's system from damages resulting from the parallel operation of the CBRE Facility, including such testing, records and operating procedures as more fully described Attachment F (Facility Owned by Subscriber Organization) to this Contract.
5. The Company may inspect the CBRE Facility and Subscriber Organization's interconnection facilities.
- D. System Capacity. The CBRE Facility must have a nameplate capacity, in the aggregate, of no more than _____ (_____) kW/MW to assure that the CBRE Facility has a nameplate capacity of less than 2.5MW .
- E. Company-Owned Interconnection Facilities.
 1. The Company agrees to furnish, install, operate and maintain such interconnection facilities on its side of the point of interconnection with the CBRE Facility as required for the parallel operation with the CBRE Facility and more fully described in Attachment G (Company- Owned Interconnection Facilities) to this Contract.
 2. All Company-Owned Interconnection Facilities shall be the property of the Company. Where portions of the Company-Owned Interconnection Facilities are located on the Subscriber Organization's premises, the Subscriber Organization shall provide, at no expense to the Company, a suitable location for and access to all such equipment. If a 120/240 Volt power source or sources are required, the Subscriber Organization shall provide these at no expense to the Company.
 3. Subscriber Organization agrees to pay to the Company a non-refundable initial payment as contribution for the Company's investment in development of the Company-Owned Interconnection Facilities and to pay for all other interconnection costs (the "Total Estimated Interconnection Costs"), as more fully described in Attachment G (Company-Owned Interconnection Facilities). The Total Estimated Interconnection Costs shall not include the cost of an initial technical screening (under Rule 14H) of the impact of the CBRE Facility on the Company's system.
 4. Governmental Approvals for Company-Owned Interconnection Facilities. Subscriber Organization shall obtain at its sole cost and expense all Governmental Approvals necessary to the construction, ownership, operation and maintenance of the Company-Owned Interconnection Facilities. Subscriber Organization shall provide all Governmental Approvals necessary for the construction of such Company-Owned Interconnection Facilities prior to the commencement of construction by Company.
- F. Credit Assurance and Security. Subscriber Organization is required to post and maintain Development Security and Operating Security based on the requirements of this Section 11.F (Credit Assurance and Security).
 1. Development Security. To guarantee undertaking the performance of Subscriber Organization's obligations under the Contract for the period prior to the Commercial Operations Date (including but not limited to Subscriber Organization's obligation to meet the Commercial Operations Date Deadline), Subscriber Organization shall post and maintain development period security ("Development Security") in an amount not less than twenty-five percent (25%) of the Total Estimated Interconnection Costs for the Company-Owned Interconnection Facilities within thirty (30) Days of Execution Date of the Contract.
 2. Return of Development Security. The Development Security shall be returned to Subscriber Organization, subject to Company's right to draw from the Development Security as set forth in Section 11.F.6 (Company's Right to Draw from Security Funds), in the following circumstances: (i) this Contract is declared null and void under Section 3.E (Contract Null and Void) or this Contract is terminated prior to the Commercial Operations Date but, in each case, only after all amounts which may be due and owing to Company are paid in full by Subscriber Organization, including by draw upon such Development Security or (ii) following Company's receipt of Operating Security pursuant to Section F.3 (Operating Security).
 3. Operating Security. To guarantee the performance of Subscriber Organization's obligations under the Contract for the period starting from the Commercial Operations Date to the expiration or termination of this Contract, Subscriber Organization shall provide satisfactory operating period security to Company in the amount of \$75/kW based on the Contract Capacity (the "Operating Security"). Subscriber Organization shall provide such Operating Security to Company within five (5) Business Days after the Commercial Operations Date, provided that, at all times, some form of Security Funds shall be in place and available to Company, whether Development Security or Operating Security.

4. Form of Security. Subscriber Organization shall supply the Development Security and Operating Security required in the form of an irrevocable standby letter of credit with no documentation requirement substantially in the form attached to this Contract as Attachment G-1 (Form of Letter of Credit) from a bank chartered in the United States with a credit rating (as measured by Standard & Poor's) of "A-" or better. If the rating of the bank issuing the standby letter of credit falls below A-, Company may require Subscriber Organization to replace, within thirty (30) Days' notice by Company, the standby letter of credit with a standby letter of credit from another bank chartered in the United States with a credit rating of "A-" or better. Such letter of credit shall be issued for a minimum term of one (1) year and shall be automatically renewed for at least an additional one (1) year term so that at the time of such renewal, the remaining term of any such security shall not be less than one (1) year. The reasonable costs and expenses of establishing, renewing, substituting, canceling, increasing, reducing, or otherwise administering the letter of credit shall be borne by Subscriber Organization.
5. Security Funds. The Development Security and Operating Security, including L/C Proceeds therefrom (collectively referred to as the "Security Funds") established, funded, and maintained by Subscriber Organization pursuant to the provisions of this Section 11.F (Credit Assurance and Security) shall provide security for the performance of Subscriber Organization's obligations under this Contract and shall be available to be drawn on by Company as provided in Section 11.F.6 (Company's Right to Draw from Security Funds). Subscriber Organization shall maintain the Security Funds at the contractually-required level throughout the Term of this Contract. Subscriber Organization shall replenish the Security Funds to such required level within fifteen (15) Business Days after any draw on the Security Funds by Company or any reduction in the value of Security Funds below the required level for any other reason. Notwithstanding the foregoing, Subscriber Organization's obligation to replenish the Development Security shall not exceed in total four (4) times the original amount of the Development Security required under Section 11.F.1 (Development Period Security) of this Contract.
6. Company's Right to Draw from Security Funds. In addition to any other remedy available to it, Company may, before or after termination of this Contract, draw from the Security Funds such amounts as are necessary to recover amounts Company is owed pursuant to this Contract, any accompanying letter agreements associated with the Contract for other work, such as the IRS, to be paid by Subscriber Organization, including, without limitation, any damages due Company, any interconnection costs owed pursuant to Attachment G (Company-Owned Interconnection Facilities) and any amounts for which Company is entitled to indemnification under this Contract. Company may, in its sole discretion, draw all or any part of such amounts due Company from any of the Security Funds to the extent available pursuant to this Section 11.F (Credit Assurance and Security), and from all such forms, and in any sequence Company may select. Any failure to draw upon the Security Funds or other security for any damages or other amounts due Company shall not prejudice Company's rights to recover such damages or amounts in any other manner.
7. Failure to Renew or Extend Letter of Credit. If the letter of credit is not renewed or extended at least thirty (30) Days prior to its expiration or earlier termination, Company shall have the right to draw immediately upon the full amount of the letter of credit and, at Company's sole option, to place the proceeds of such draw (the "L/C Proceeds"), at Subscriber Organization's cost, in an escrow account until and unless Subscriber Organization provides a substitute letter of credit meeting the requirements of this Section 11.F (Credit Assurance and Security). If Company elects, the L/C Proceeds shall be deposited with a reputable escrow agent acceptable to Company ("Escrow Agent"). Without limitation to the generality of the foregoing, a federally-insured bank shall be deemed to be a "reputable escrow agent." Company shall have the right to apply the L/C Proceeds as necessary to recover amounts Company is owed as specified in Section 11.F.6 (Company's Right to Draw from Security Funds). The documentation governing such escrow account shall be in form and content satisfactory to Company and shall give Company the sole authority to draw from the escrow account. Subscriber Organization shall not be a party to such documentation and shall have no rights to the L/C Proceeds. If an adequate substitute letter of credit is obtained and provided to Company, the net L/C Proceeds remaining as of the date that such substitute

letter of credit is provided, shall be returned to Subscriber Organization, or as Subscriber Organization directs in writing.

8. Release of Security Funds. Upon the end of the Term and the complete performance of all of Subscriber Organization's obligations under this Contract, including but not limited to the obligation to pay any and all amounts owed by Subscriber Organization to Company under this Contract, Company shall release the Security Funds to Subscriber Organization.

12. **PERSONNEL AND SYSTEM SAFETY.** Notwithstanding any other provisions of this Contract, if at any time Company determines that the Facility may endanger Company's personnel, and/or the continued operation of the Facility may endanger the integrity of the Company System or have an adverse effect on Company's other customers' electric service, Company shall have the right to disconnect the Facility from the Company System, as determined in the sole discretion of the Company System Operator. The Facility shall immediately comply with the dispatch instruction, which may be initiated through remote control, and shall remain disconnected (and in Subscriber Organization-Attributable Non-Generation status if so determined), until such time as Company is satisfied that the condition(s) referred to above have been corrected. If Company disconnects the Facility from the Company System for personnel or system safety reasons, it shall as soon as practicable notify Subscriber Organization by telephone, and thereafter make reasonable efforts to confirm, in writing (with email being acceptable), within three (3) Days of the disconnection, the reasons for the disconnection. If the reason for the disconnection constitutes Subscriber Organization-Attributable Non-Generation, Company will notify Subscriber Organization (i) whether the conditions resulting in such disconnection have been resolved (in which case no additional time after such confirmation shall count as Subscriber Organization-Attributable Non-Generation); or (ii) that conditions resulting in such disconnection have not been resolved so that Subscriber Organization can take such appropriate corrective actions. Subscriber Organization shall notify Company in writing when such corrective action has been completed; provided, however, that Subscriber Organization shall remain in Subscriber Organization-Attributable Non-Generation until Company is satisfied that the condition resulting in the disconnection has been corrected. Company shall use reasonable efforts to inspect such corrective measures (if necessary) and confirm the resolution of such condition within three (3) Business Days after Subscriber Organization's notification.

13. EVENTS OF DEFAULT BY SUBSCRIBER ORGANIZATION.

- A. The occurrence of any of the following shall constitute an "Event of Default" by Subscriber Organization:
 1. If at any time during the Term, Subscriber Organization delivers or attempts to deliver to the Point of Interconnection for sale under this Contract renewable energy that was not produced by the CBRE Facility and Subscriber Organization fails to cease such delivery or attempt to deliver such renewable energy within ten (10) Days after Company's written notice of such delivery or attempt.
 2. If at any time subsequent to the Commercial Operations Date, the PV System Equivalent Availability Factor is less than [84%] for each of three consecutive Contract Years.
 3. If at any time subsequent to the Commercial Operations Date, the Measured Performance Ratio for each of three consecutive Contract Years falls below the Tier 2 Bandwidth for such Contract Year.
 4. If at any time subsequent to the Commercial Operations Date, the Subscriber Organization fails to demonstrate satisfaction of the BESS Capacity Performance Metric prior to the expiration of the BESS Capacity Cure Period.
 5. If at any time subsequent to the Commercial Operations Date, the Subscriber Organization fails to achieve a BESS Annual Equivalent Availability Factor of not less than [75%] for each of four (4) consecutive BESS Measurement Periods as provided in Section 4.B (BESS Annual Equivalent Availability Factor; Liquidated Damages; Termination Rights) of Attachment C (Required Performance Metrics; Liquidated Damages) to this Contract.
 6. If at any time subsequent to the Commercial Operations Date, Subscriber Organization fails to demonstrate satisfaction of the RTE Performance Metric prior to the expiration of the RTE Cure Period.

7. If at any time subsequent to the Commercial Operations Date, the Facility is unavailable to provide electric energy in response to dispatch by Company for a period of three hundred sixty-five (365) or more consecutive Days.
8. If at any time during the Term, Subscriber Organization fails to satisfy the requirements of Section 11.F (Credit Assurance and Security) of this Contract.
9. If at any time subsequent to the Commercial Operations Date, Subscriber Organization fails to take all corrective actions specified by the Company's written notice that the CBRE Facility is out of compliance with the terms of this Contract, within the timeframe set forth in such notice.
10. If at any time subsequent to the Commercial Operations Date, Subscriber Organization fails to install, operate, maintain, or repair the Facility in accordance with Good Engineering and Operating Practices if such failure is not cured within thirty (30) Days after written notice of such failure from Company unless such failure cannot be cured within said thirty (30) Day period and Subscriber Organization is making commercially reasonable efforts to cure such failure, in which case Subscriber Organization shall have a cure period of three hundred sixty-five (365) Days after Company's written notice of such failure.
11. The failure to make any payment required pursuant to this Contract when due if such failure is not cured within ten (10) Business Days after written notice is received by Subscriber Agreement.
12. If any representation or warranty made to Company by Subscriber Organization herein is false and misleading in any material respect when made.
13. Subscriber Organization becomes insolvent, or makes an assignment for the benefit of creditors; or shall have an order for relief in an involuntary case under the bankruptcy Laws as now or hereafter constituted entered against it, or shall commence a voluntary case under the bankruptcy Laws as now or hereafter constituted, or shall file any petition or answer seeking for itself any arrangement, composition, adjustment, liquidation, dissolution or similar relief to which it may be entitled under any present or future Law; or seeks or consents to or acquiesces in the appointment of or taking possession by, any custodian, trustee, receiver or liquidator of it or of all or a substantial part of its properties or assets; or takes action looking to its dissolution or liquidation, and Subscriber Organization is unable to remedy such actions within one hundred eighty (180) Days of the occurrence of such breach or default.
14. Subscriber Organization fails to comply with the applicable term, conditions and minimum requirements specified in the CBRE Tariff governing Subscriber Organization's CBRE Facility, if such failure is not cured within thirty (30) Days after written notice of such failure from Company.
15. Subscriber Organization fails to comply with a decision under Section 17 (Dispute Resolution) within thirty (30) Days after such decision or, if such decision cannot be complied with within thirty (30) Days, Subscriber Organization fails to have commenced commercially reasonable efforts designed to achieve compliance within such thirty (30) Days and diligently continue such commercially reasonable efforts until compliance is attained, but no longer than one hundred twenty (120) Days;
16. Other than the events of default specified in this Section 13. A.1 through Section 13.A.15, should Subscriber Organization, by act or omission, materially breach or default on any other material covenant, condition or other provision of this Contract, and if such breach or default is not cured within thirty (30) Days after written notice of such breach or default from Company, such failure to cure shall constitute an Event of Default; provided, however, that if it is objectively impossible to cure such breach or default within said thirty (30) Day period, then, for so long as Subscriber Organization is making the same effort to cure such breach or default as would be expected of an experienced independent power producer willing and able to exert commercially reasonable efforts to achieve such cure, Subscriber Organization shall have a cure period equal to three hundred sixty-five (365) Days beginning on the date of Company's written notice of such breach or default; provided, further, that if the material breach in question involves Subscriber Organization's failure to meet the operational and performance standards set forth in Attachment F (Facility Owned by Subscriber Organization), the provisions of Section 1(j) (Demonstration of Facility) of Attachment F (Facility Owned by Subscriber Organization) for consultant's study and Subscriber Organization implementation of such study's recommendation shall apply in lieu of the extended cure period provided under the preceding proviso.

14. TERMINATION FOR CAUSE.

A. Upon an Event of Default by the Subscriber Organization:

1. Company shall provide written notice to the Subscriber Organization to remedy the Event of Default within the applicable cure period specified for such Event of Default, if any.
 2. If after the cure period, if any, provided for in the Company's notice Subscriber Organization is still not in compliance with this Contract, then the Company shall have the right to terminate the Contract, as follows:
 - a. Company shall issue a written a Notice of Intent to Terminate the Contact for just cause;
 - b. Subscriber Organization shall have five (5) Business Days in which to provide evidentiary documentation reasonably establishing that Company's decision to terminate the Contract is in error.
 - c. If the Subscriber Organization fails to provide such proof or if the Company reasonably determines that such proof is insufficient to reverse the Company's decision to terminate, Company may proceed to terminate the Contract by providing a written Notice of Termination to Subscriber Organization. A copy of such notice shall be provided to all Subscribers of the CBRE Facility, the PUC, and the CBRE IO, if applicable.
 3. The termination date in the notice of termination shall not be earlier than thirty (30) Days from the date of such notice.
 4. Subscriber Organization acknowledges that Company is a public utility and is relying upon Subscriber Organization's performance of its obligations under this Contract, and that Company and/or its customers may suffer irreparable injury as a result of the failure of Subscriber Organization to perform any of such obligations, whether or not such failure constitutes an Event of Default or otherwise gives rise to a termination for cause of this Contract. Accordingly, Company shall have right to seek specific performance injunctions or other available equitable remedies for Subscriber Organization's failure to perform any of its obligations under this Contract, irrespective of whether such failure constitutes an Event of Default.
 5. In the event of any breach of this Contract by Company, the Subscriber Organization shall provide Company with a written notice of the breach. Company shall have up to thirty (30) Days to cure the breach. If the breach is not cured within the thirty (30) Days, the Subscriber Organization may utilize the procedures set forth in Section 17. (Dispute Resolution) of this Contract. If the breach results in Bill Credits not being issued to one or more individual Subscribers, in the absence of a cure by Company within the allowed time following the notice, the Subscriber Organization may also seek a remedy on behalf of the affected Subscribers for any past due Bill Credits pursuant to the process set forth in Section 17. of this Contract.
- B. Following Termination, applicable provisions shall continue in effect after termination to the extent necessary to enforce and complete the duties, obligations or responsibilities of the Parties arising prior to termination and, as applicable, to provide for final billings and adjustments related to the period prior to termination, repayment of any money due and owing to either Party pursuant to this Contract.

15. DAMAGES IN THE EVENT OF TERMINATION BY COMPANY.

- A. Termination Due to an Event of Default. If the Contract is terminated by Company in accordance with this Contract after the Commercial Operations Date due to an Event of Default, Company shall be entitled to Termination Damages calculated by multiplying the Contract Capacity by [\$75/kW].
- B. Termination Damages Appropriate. Subscriber Organization agrees and acknowledges that (i) the damages that Company would incur due to early termination of the Contract would be difficult or impossible to calculate with certainty, (ii) the Termination Damages are an appropriate approximation of such damages, and (iii) payment of Termination Damages does not relieve Subscriber Organization of liability for costs and balances incurred prior to the effective date of such termination. The Termination Damages are not intended to limit Company's rights or remedies, or Subscriber Organization's liabilities or duties, with respect to losses arising independent of the termination of this Contract for an Event of Default before the Commercial Operations Date, including, without limitation, Company's right to recover under Section 16. (Limitation of Liability).

16. LIMITATION OF LIABILITY.

- A. Each Party shall at all times indemnify, defend, and save the other Party harmless from any and all damages, losses, claims, including claims and actions relating to injury or death of any person or damage to property, costs and expenses, reasonable attorneys' fees and court costs, arising out of or resulting from the Party's performance of its obligations under this Contract, except to the extent that such damages, losses or claims were caused by the negligence or intentional acts of the other Party.
- B. Each Party's liability to the other Party for failure to perform its obligations under this Contract shall be limited to the amount of direct damage actually incurred. In no event shall either Party be liable to the other Party for any punitive, incidental, indirect, special, or consequential damages of any kind whatsoever, including for loss of business opportunity or profits, regardless of whether such damages were foreseen.
- C. Notwithstanding any other provision of the Contract or this Section 16., with respect to the Company's duties or performance or lack of performance under this Contract, the Company's liability to the Subscriber Organization shall be limited as set forth in the Company's rate book and terms and conditions for electric service, which shall not be affected by the terms of this Contract. There are no third-party beneficiaries of any Company duty under this Contract other than the Company's duty to Subscribers to issue Bill Credits as set forth in this Contract.
- D. Indemnification of Company Against Third Party Claims. Subscriber Organization shall indemnify, defend, and hold harmless Company, its successors, permitted assigns, affiliates, controlling persons, directors, officers, employees, agents, contractors, subcontractors and the employees of any of them (collectively referred to as an "Indemnified Company Party"), from and against any Losses suffered, incurred or sustained by any Indemnified Company Party due to any Claim (whether or not well founded, meritorious or unmeritorious) by a third party not controlled by, or under common ownership and/or control with, Company relating to (i) the Subscriber Agreement between Subscriber Organization and its Subscribers or (ii) Subscriber Organization's development, permitting, construction, ownership, operation and/or maintenance of the CBRE Facility.

17. DISPUTE RESOLUTION.

- A. Notwithstanding the provisions of this Contract allowing for early termination following an Event of Default, each Party agrees to attempt to resolve all disputes arising hereunder promptly, equitably and in a good faith manner.
- B. Before submitting any claims, controversies or disputes ("Dispute(s)") under this Contract to the Dispute Resolution Procedures set forth below in Section C., the presidents, vice presidents, or authorized delegates from both Subscriber Organization and Company having full authority to settle the Dispute(s), shall personally meet in Hawai'i and attempt in good faith to resolve the Dispute(s) (the "Management Meeting").
- C. Dispute Resolutions Procedures, Mediation. Any and all Dispute(s) arising out of or relating to this Contract, (i) which remain unresolved for a period of 20 Days after the Management Meeting takes place or (ii) for which the Parties fail to hold a Management Meeting within sixty (60) Days of the date that a Management Meeting was requested by a Party, may upon the agreement of the Parties, first be submitted to confidential mediation in Honolulu, Hawai'i pursuant to the administration by, and in accordance with the Mediation Rules, Procedures and Protocols of, Dispute Prevention & Resolution, Inc. (or its successor) or, in their absence, the American Arbitration Association ("DPR") then in effect. If the Parties agree to submit the dispute to confidential mediation, the parties shall each pay 50% of the cost of the mediation (i.e., the fees and expenses charged by the mediator and DPR) and shall otherwise each bear their own mediation costs and attorneys' fees. If the Parties do not submit the Dispute(s) to mediation, or if they do submit the Dispute(s) to mediation but settlement of the Dispute(s) is not reached within 60 Days after commencement of the mediation, either Party may initiate legal proceedings in a court of competent jurisdiction in the State of Hawai'i.

- 18. ENVIRONMENTAL CREDITS. Included in the purchase and sale of renewable energy are all of the Environmental Credits associated with the renewable energy. Company will not reimburse Subscriber Organization for any taxes or fees imposed on Subscriber Organization including, but not limited to, State of

Hawai'i general excise tax. To the extent not prohibited by law, Company shall have the sole and exclusive right to use the renewable energy purchased hereunder to meet RPS and any Environmental Credit shall be the property of Company; provided, however, that such Environmental Credits shall be to the benefit of Company's ratepayers in that the value must be credited "above the line." Subscriber Organization shall use all commercially reasonable efforts to ensure such Environmental Credits are vested in Company, and shall execute all documents, including, but not limited to, documents transferring such Environmental Credits, without further compensation; provided, however, that Company agrees to pay for all reasonable costs associated with such efforts and/or documentation.

19. REPRESENTATIONS AND WARRANTIES.

A. Company and Subscriber Organization represent and warrant, respectively, that:

1. Each respective Party has all necessary right, power and authority to execute, deliver and perform this Contract.
2. The execution, delivery and performance of this Contract by each respective Party will not result in a violation of any Laws, or conflict with, or result in a breach of, or cause a default under, any agreement or instrument to which such Party is also a party or by which it is bound. No consent of any person or entity not a Party to this Contract, other than governmental agencies whose approval is necessary for construction of the CBRE Facility and interconnection facilities, is required for such execution, delivery and performance by either Party.

B. Subscriber Organization represents, warrants and covenants that:

1. Subscriber Organization has obtained all Land Rights necessary for the construction, ownership, operation and maintenance of the CBRE Facility during the Term, and Subscriber Organization shall maintain such Land Rights in effect throughout the Term.
2. As of the commencement of construction, Subscriber Organization shall have obtained all permits or approvals from any applicable governmental agency necessary for the construction, ownership, operation and maintenance of the CBRE Facility and all interconnection facilities.
3. Subscriber Organization warrants that the CBRE Facility complies with all applicable federal and state Laws, including but not limited to (a) all applicable securities Laws and shall continue to be in compliance for the duration of the Term; (b) complies with all applicable Laws concerning the dissemination of personally identifiable information, and shall continue to be in compliance for the longer of (i) the Term and (ii) for as long as Subscriber Organization continues to hold or otherwise have access to any personally identifiable information of Subscribers or customers of Company; (c) complies with all applicable Laws concerning consumer protection, and shall continue to be in compliance for the duration of the Term; (d) complies with all applicable Laws and regulations concerning renewable energy grid interconnections, and shall continue to be in compliance for the duration of the Term.

20. SUBSCRIBER ORGANIZATION AND CBRE FACILITY INFORMATION. By signing this Contract, the Subscriber Organization expressly agrees and authorizes the Company to request and obtain from Subscriber Organization and its contractors, vendors, subcontractors, installers, suppliers or agents (collectively "Subscriber Organization Agents"), at no cost to Company, information related to the CBRE Facility, including but not limited to Watts, Vars, Watt Hours, current and voltage, status of the CBRE Facility, inverter settings, any and all recorded event or alarm logs recorded, (collectively "CBRE Facility Data") that Company reasonably determines are needed to ensure the safe and reliable operation of the CBRE Facility or the Company's system. Subscriber Organization expressly agrees and irrevocably authorizes Subscriber Organization Agents to disclose such Subscriber Organization Data to Company upon request by Company.

21. ADDITIONAL INFORMATION. The Company reserves the right to request additional information from Subscriber Organization relating to the CBRE Facility, where reasonably necessary, to serve the Subscriber Organization under this Contract or to ensure reliability, safety of operation, and power quality of the Company's system.

- 22. NO MATERIAL CHANGES TO CBRE FACILITY.** The Subscriber Organization agrees that no material changes or additions to the CBRE Facility shall be made without having obtained prior written consent from the Company, which consent shall not be unreasonably withheld. In no event may the Total Rated Capacity of the CBRE Facility exceed _____ kW. If the CBRE Facility changes ownership, the Company may require the new Subscriber Organization to complete and execute an amended Contract or new Contract, as may be applicable.
- 23. CERTIFICATION BY LICENSED ELECTRICAL CONTRACTOR.** The CBRE Facility and all interconnection systems must comply with all applicable safety and performance standards of the National Electrical Code (NEC), Institute of Electrical and Electronic Engineers (IEEE), and accredited testing laboratories such as the Underwriters Laboratories (UL), and where applicable, the rules of the Commission, or other applicable governmental laws and regulations, and the Company's interconnection requirements, in effect at the time of signing this Contract. This requirement shall include, but not be limited to, the interconnection standards and procedures of the Company's Rule 14H, as well as any other requirements as may be specified in this Contract, its Attachments, Exhibits, and as authorized by the Commission. Upon request by Company, Subscriber Organization shall cause a Licensed Electrical Contractor, as agent for Subscriber Organization, to certify that once approved by the Company, the proposed CBRE Facility will be installed to meet all preceding requirement(s).
- 24. GOOD ENGINEERING PRACTICE.**
- A. Each Party agrees to install, operate and maintain its respective equipment and facilities and to perform all obligations required to be performed by such Party under this Contract in accordance with good engineering practice in the electric industry and with applicable laws, rules, orders and tariffs.
 - B. Wherever in this Contract and its Attachments and Exhibits the Company has the right to give specifications, determinations or approvals, such specifications, determinations and/or approvals shall be given in accordance with the Company's standard practices, policies and procedures, which may include the Company's Electric Service Installation Manual, the Company's Engineering Standard Practice Manual and the IEEE Guides and Standards for Protective Relaying Systems.
- 25. INSURANCE.** The following insurance provisions are only applicable to CBRE Facilities with a Total Rated Capacity 250 kW or greater but not exceeding 2.5 MW:
- A. The Subscriber Organization shall, at its own expense and during the term of the Contract and any other time that the CBRE Facility is interconnected with the Company's system, maintain in effect with a responsible insurance company authorized to do insurance business in Hawai'i and with a rating by A.M. Best Company, Inc. of "A-VII" or better, the following insurance or its equivalent at Company's discretion that will protect the Subscriber Organization and the Company with respect to the CBRE Facility, the CBRE Facility's operations, and the CBRE Facility's interconnection with the Company's system:
 - 1. A Commercial General Liability policy covering bodily injury and property damage with combined single limit of liability of at least the following amounts based on the Total Rated Capacity of the generator (for solar systems—Total Rated Capacity of the generator or inverter, whichever is lower, can be used with appropriate technical documentation on inverter, if not higher Total Rated Capacity will be used), for any occurrence. The limits below may be satisfied through the use of umbrella or excess liability insurance sufficient to meet these requirements:

COMMERCIAL GENERAL LIABILITY COVERAGE AMOUNT	TOTAL RATED CAPACITY OF THE CBRE FACILITY
\$5,000,000	Greater than 1 MW and less than or equal to 5 MW
\$2,000,000	250 kW and less than or equal to 1 MW

2. Said insurance by endorsement to the policy or policies shall: name the Company, its directors, officers, agents, and employees as additional insured; include contractual liability coverage for written agreements; include provisions stating that the insurance will respond to claims or suits by additional insureds against the Subscriber Organization or any other insured thereunder; provide that the insurance is primary with respect to the Subscriber Organization and the Company; and provide that the insurance company waives all rights of subrogation which Subscriber Organization or the insurance company may have against Company, its directors, officers, agents, and employees. Any insurance carried by Company will be excess only and not contribute with this insurance.
- B. Said insurance by endorsement to the policy or policies shall provide written notice within thirty (30) Days to the Company should the required insurance be cancelled, limited in scope, or not renewed upon expiration. "Claims made" policies are not acceptable, unless the Subscriber Organization agrees to maintain coverage in full effect at all times during the term of this Contract and for THREE (3) years thereafter. The adequacy of the coverage afforded by the required insurance shall be subject to review by the Company from time to time, and if it appears in such review that risk exposures require an increase in the coverages and/or limits of this insurance, the Subscriber Organization shall make such increase to that extent and any increased costs shall be borne by the Subscriber Organization. The Subscriber Organization has the responsibility to determine if higher limits are desired and purchased. The Subscriber Organization shall provide certificates of insurance to the Company prior to executing the Contract and any parallel interconnection. Receipt of any certificate showing less coverage than required shall not operate as a waiver by the Company of the Subscriber Organization's obligation to fulfill the applicable requirements of this Section 25. The Subscriber Organization's indemnity and other obligations shall not be limited by the foregoing insurance requirements. Any deductible shall be the responsibility of the Subscriber Organization.
- C. Alternatively, where the Subscriber Organization is a governmental entity, Subscriber Organization may elect to be self-insured for the amounts set forth above in lieu of obtaining insurance coverage to those levels from an insurance company.

26. MISCELLANEOUS.

- A. Disconnection and Survival of Obligations. Upon termination of this Contract, the CBRE Facility shall be disconnected from the Company's system. The termination of this Contract shall not relieve the Parties of their respective liabilities and obligations, owed or continuing at the time of termination.
- B. Governing Law and Regulatory Authority. This Contract was executed in the State of Hawai'i and must in all respects be interpreted, governed, and construed under the laws of the State of Hawai'i. This Contract is subject to, and the Parties' obligations hereunder include, operating in full compliance with all valid, applicable federal, state, and local laws or ordinances, and all applicable rules, regulations, orders of, and tariffs approved by, duly constituted regulatory authorities having jurisdiction.
- C. Amendment, Modifications, or Waiver. This Contract may not be altered or modified by either of the Parties, except by an instrument in writing executed by each of them. None of the provisions of this Contract shall be considered waived by a Party unless such waiver is given in writing. The failure of a Party to insist in any one or more instances upon strict performance of any of the provisions of this Contract or to take advantage of any of its rights hereunder shall not be construed as a waiver of any such provisions or the relinquishment of any such rights for the future, but the same shall continue and remain in full force and effect. This Contract contains the entire agreement and understanding between the Parties, their agents, and employees as to the subject matter of this Contract. Each Party also represents that in entering into this Contract, it has not relied on any promise, inducement, representation, warranty, agreement or other statement not set forth in this Contract.
- D. Notices. Any notice required under this Contract shall be in writing and mailed at any United States Post Office with postage prepaid and addressed to the Party, or personally delivered to the Party at the address identified on the last page of the Contract. Changes in such designation may be made by notice similarly given.

Notice sent by mail shall be deemed to have been given on the date of actual delivery or at the expiration of the fifth day after the date of mailing, whichever is earlier.

- E. Assignment. This Contract may not be assigned by either Party without the prior written consent of the other Party. Such consent shall not be unreasonably withheld. In the event of an assignment for financing, to the extent necessary, Company shall, if requested by Subscriber Organization and if its costs (including reasonable attorneys' fees of outside counsel) in responding to such request are paid by Subscriber Organization execute such Hawai'i-law-governed documents as may be reasonably requested by a lender in connection with CBRE Facility debt and reasonably acceptable to Company, to acknowledge an assignment of such debt and/or pledge/mortgage.
- F. Binding Effect. This Contract shall be binding upon and inure to the benefit of the Parties hereto and their respective successors, legal representatives, and permitted assigns.
- G. Relationship of Parties. Nothing in this Contract shall be deemed to constitute any Party hereto as partner, agent or representative of the other Party or to create any fiduciary relationship between the Parties.
- H. Limitations. Nothing in this Contract shall limit the Company's ability to exercise its rights or expand or diminish its liability with respect to the provision of electrical service pursuant to the Company's tariffs as filed with the Commission, or the Commission's Standards for Electric Utility Service in the State of Hawai'i, which currently are included in the Commission's General Order Number 7, as either may be amended from time to time.
- I. Non-Warranty. Neither by inspection, if any, or non-rejection, nor in any other way, does the Company give any warranty, express or implied, as to the adequacy, safety, or other characteristics of any structures, equipment, wires, appliances or devices owned, installed or maintained by the Subscriber Organization or leased by the Subscriber Organization from third parties, including without limitation the CBRE Facility and any structures, equipment, wires, appliances or devices appurtenant thereto.
- J. Hawai'i General Excise Tax. Subscriber Organization shall, when making payments to Company under this Contract, pay such additional amount as may be necessary to reimburse Company for the Hawai'i general excise tax on gross income and all other similar taxes imposed on Company by any Governmental Authority with respect to payments in the nature of gross receipts tax, sales tax, privilege tax or the like, but excluding federal or state net income taxes. By way of example and not limitation, as of the Execution Date, all payments subject to the Hawai'i general excise tax, (i) on the islands of Maui, Moloka'i and Lana'i (totaling 4.0% as of the Execution Date) would include an additional 4.166% so that the underlying payment will be net of such tax liability; and (ii) all payments subject to general excise tax plus surcharge on Hawai'i island (totaling 4.5% as of the Execution Date) would include an additional 4.7120% so the underlying payment will be net of such tax liability.
- K. Execution of Contract; Multiple Counterparts. The Parties agree that this Contract, including amendments, may be executed and delivered by exchange of electronic signatures, which may be transmitted by facsimile, e-mail, or other acceptable means. A party's electronic signature shall be considered an "original" signature which is binding and effective for all purposes. This Contract may be executed in counterparts, each of which shall be deemed an original, and all of which shall together constitute one and the same instrument binding all Parties.
- L. Survival. The rights and obligations of the Parties in this Contract which, by its express terms or nature and context is intended to survive termination or expiration of this Contract, will survive any such termination or expiration.

27. FORCE MAJEURE.

- A. Definition of Force Majeure. The term "Force Majeure", as used in this Contract, means any occurrence that:
 1. In whole or in part delays or prevents a Party's performance under this Contract;
 2. Is not the direct or indirect result of the fault or negligence of that Party;
 3. Is not within the control of that Party notwithstanding such Party having taken all reasonable precautions and measures in order to prevent or avoid such event; and
 4. The Party has been unable to overcome by the exercise of due diligence.

- B. Events That Could Qualify as Force Majeure. Subject to the foregoing, events that could qualify as Force Majeure include, but are not limited to, the following: acts of God, flooding, lightning, landslide, earthquake, fire, drought, explosion, epidemic, quarantine, storm, hurricane, tornado, volcano, other natural disaster or unusual or extreme adverse weather-related events; war (declared or undeclared), riot or similar civil disturbance, acts of the public enemy (including acts of terrorism), sabotage, blockade, insurrection, revolution, expropriation or confiscation; or strikes, work stoppage or other labor disputes (in which case the affected Party shall have no obligation to settle the strike or labor dispute on terms it deems unreasonable).
- C. Exclusions From Force Majeure. Force Majeure does not include:
1. any acts or omissions of any Third Party, including, without limitation, any vendor, materialman, customer, or supplier of Subscriber Organization, unless such acts or omissions are themselves excused by reason of Force Majeure;
 2. any full or partial reduction in the electric output of Facility that is caused by or arises from (i) a mechanical or equipment breakdown or (ii) other mishap or events or conditions attributable to normal wear and tear or defects, unless such mishap is caused by Force Majeure;
 3. changes in market conditions that affect the cost of Subscriber Organization's supplies, or that affect demand or price for any of Subscriber Organization's products, or that otherwise render this Contract uneconomic or unprofitable for Subscriber Organization;
 4. Subject to Section 10. I. of this Contract, Subscriber Organization's inability to obtain Governmental Approvals or Land Rights for the construction, ownership, operation and maintenance of Facility and the Company-Owned Interconnection Facilities, or Subscriber Organization's loss of any such Governmental Approvals or Land Rights once obtained;
 5. the lack of wind, sun or any other resource of an inherently intermittent nature;
 6. Subscriber Organization's inability to obtain sufficient fuel, power or materials to operate its Facility, except if Subscriber Organization's inability to obtain sufficient fuel, power or materials is caused solely by an event of Force Majeure;
 7. Subscriber Organization's failure to obtain additional funds, including funds authorized by a state or the federal government or agencies thereof, to supplement the payments made by Company pursuant to this Contract;
 8. a Forced Outage except where such Forced Outage is caused by an event of Force Majeure;
 9. litigation or administrative or judicial action pertaining to the Contract, the Site, the Facility, the Land Rights, the acquisition, maintenance or renewal of financing or any Governmental Approvals, or the design, construction, ownership, operation or maintenance of the Facility, the Company-Owned Interconnection Facilities or the Company System;
 10. a strike, work stoppage or labor dispute limited only to any one or more of the Indemnified Subscriber Organization Parties or any other third party employed by Subscriber Organization to work on the Project; or
 11. any full or partial reduction in the availability of the Facility to produce and deliver to the Point of Interconnection electric energy in response to Company Dispatch which is caused by any Third Party including, without limitation, any vendor or supplier of Subscriber Organization or Company, except to the extent due to Force Majeure.
- D. Satisfaction of Certain Conditions. This Contract defer or limit certain liabilities of a Party for delay and/or failure in performance to the extent such delay or failure is the result of conditions or events of Force Majeure; provided, however, that a Non-performing Party is only entitled to such limitations or deferrals of liabilities as and to the extent the following conditions are satisfied:
1. the Non-performing Party gives the other Party, within five (5) Days after the Non-performing Party becomes aware or should have become aware of the Force Majeure condition or event, but in any event no later than thirty (30) Days after the Force Majeure condition or event begins, written notice (the "Force Majeure Notice") stating that the Non-performing Party considers such condition or event to constitute Force Majeure and describing the particulars of such Force Majeure condition or event, including the date the Force Majeure commenced;

2. the Non-performing Party gives the other Party, within fourteen (14) Days after the Force Majeure Notice was or should have been provided, a written explanation of the Force Majeure condition or event and its effect on the Non-performing Party's performance, which explanation shall include evidence reasonably sufficient to establish that the occurrence constitutes Force Majeure;
 3. the suspension of performance is of no greater scope and of no longer duration than is required by the condition or event of Force Majeure;
 4. the Non-performing Party exercises commercially reasonable efforts to remedy its inability to perform and provides written weekly progress reports to the other Party describing actions taken to end the Force Majeure; and
 5. when the condition or event of Force Majeure ends and the Non-performing Party is able to resume performance of its obligations under this Contract, that Party shall give the other Party written notice to that effect.
- E. Termination for Force Majeure. If Force Majeure delays or prevents a Party's performance for more than three hundred sixty-five (365) Days from the occurrence or inception of the Force Majeure, as stated in the Force Majeure Notice, and such delay or failure of performance would have otherwise constituted an Event of Default under Section 13. (Event of Default), the other Party shall have the right to terminate this Contract by written notice. Such notice shall designate the date such termination is to be effective, which date shall be no later than thirty (30) Days after such notice is deemed to be received by the Party whose performance has been delayed or prevented. In the event of termination pursuant to this Section 27.E (Termination for Force Majeure), neither Party shall be liable for any damages nor have any obligations to the other, except as provided in Section 26.L (Survival).
- F. Effect of Force Majeure. Other than as provided in Section 27.E. (Termination for Force Majeure), neither Party shall be responsible or liable for any delays or failures in its performance under this Contract as and to the extent (i) such delays or failures are substantially caused by conditions or events of Force Majeure, and (ii) the conditions of Section D. (Satisfaction of Certain Conditions) are satisfied.
- G. No Relief of Other Obligations. Except as otherwise expressly provided for in this Contract, the existence of a condition or event of Force Majeure shall not relieve the Parties of their obligations under this Contract (including, but not limited to, payment obligations) to the extent that performance of such obligations is not precluded by the condition or event of Force Majeure. No Extension of the Term. In no event will any delay or failure of performance caused by any conditions or events of Force Majeure extend this Contract beyond its stated Term.
- 28. COMMUNITY OUTREACH**
- A. The Parties acknowledge that, prior to the Execution Date, Subscriber Organization provided to Company a comprehensive community outreach and communications plan to work with and inform neighboring communities and stakeholders to gain their support for the Project ("Community Outreach and Engagement Plan"). Subscriber Organization agrees to work with neighboring communities and stakeholders and provide them timely information during all phases of the Project, including but not limited to the following information: Project description, Project stakeholders, community concerns and Subscriber Organization's efforts to address such concerns, Project benefits, government approvals, Project schedule, and a Community Outreach and Engagement Plan. Subscriber Organization's Community Outreach and Engagement Plan is a public document and shall remain available to members of the community on the Subscriber Organization's website for the Term of this Contract and upon request. Subscriber Organization shall also provide Company with links to its Project website and Community Outreach and Engagement Plan.
- B. Public Meeting; Public Comment Period. The Parties also acknowledge that, prior to the Execution Date, Subscriber Organization provided reasonable advance notice and hosted a public meeting for community and neighborhood groups in and around the vicinity of the Project site that provided neighboring community, stakeholders, and the general public with: (i) a reasonable opportunity to learn about the proposed Project; (ii) an opportunity to engage in a dialogue about concerns, mitigation measures, and potential community benefits of the proposed Project; and (iii) information concerning the process and/or intent for the public's input and engagement, including advising attendees that they will have thirty (30) Days from the date of said public meeting to submit written comments to Company and/or Subscriber Organization. Subscriber Organization

shall collect all public comments, and then provide Company copies of all comments received in their original, unedited form. Subscriber Organization agrees that it will post all comments with personal information redacted on its website for public review. Comments should remain on the Subscriber Organization's website for at least two years after the Commercial Operations Date.

- C. Subscriber Organization acknowledges and agrees that any written comments from the public regarding the CBRE Project it receives after the 30-day public comment period will be submitted to Company in their original, unedited form. Subscriber Organization further agrees to post these subsequent public comments, with personal information redacted, on its website for public review for at least two years after the Commercial Operations Date.
- D. The Parties acknowledge and agree that Subscriber Organization is responsible for community outreach and engagement for the Project, and that the public meeting and comment solicitation process described in this Section 28 (Community Outreach) do not represent the only community outreach and engagement activities that can or should be performed by Subscriber Organization. Without limitation to the generality of the preceding sentence, Subscriber Organization agrees to take into account the Project's potential impacts on historical and cultural resources and, at a minimum, Subscriber Organization shall describe: (i) any valued cultural, historical, or natural resources in the area in question, including the extent to which traditional and customary native Hawaiian rights are exercised in the area; (ii) the extent to which those resources – including traditional and customary native Hawaiian rights – will be affected or impaired by the Project; and (iii) the feasible action, if any, to be taken to reasonably protect native Hawaiian rights if they are found to exist. Subscriber Organization shall determine and implement such additional means as may be reasonably necessary to share information with and involve the community and neighborhood groups in and around the vicinity of the Facility during the Project planning and development process through the Term of this Contract, and shall timely inform Company of its plans and activities in this regard.
- E. Upon the Execution Date and at all times during the Term of this Contract, Subscriber Organization shall designate an individual as the "Subscriber Organization's Community Representative." The Subscriber Organization's Community Representative shall be the primary contact between the community and the Subscriber Organization and shall be available during the Term of this Contract to receive and answer questions from the community. As of the Execution Date, the Subscriber Organization's Community Representative shall be:
- Name: [name of Subscriber Organization's Community Representative]
 - Contact Information: [email address]
 - Subscriber Organization shall notify Company in writing upon designation of any new Subscriber Organization's Community Representative.

29. GENERATOR/EQUIPMENT CERTIFICATION. CBRE Facilities that utilize inverter technology must be compliant with Institute of Electrical and Electronics Engineers IEEE Std 1547-2018, Underwriters Laboratories UL 1741 and the Company's Source Requirement Document Version 2.0 (though not preferred, Company will accept compliance with the Company's Source Requirement Document Version 1.1 for CBRE Projects executed prior to or on June 30, 2021) as well as the Company's Rule 14H and any additional requirements contained herein that apply to CBRE Facilities. CBRE Facilities that use a rotating machine must be compliant with applicable National Electrical Code, Underwriters Laboratories, and Institute of Electrical and Electronics Engineers standards and rules and orders of the Commission in effect at the time this Contract is executed. By signing below, the Applicant certifies that the installed generating equipment will meet the appropriate preceding requirement(s) and can supply documentation that confirms compliance, including a certification of the same from the Installing Electrical Contractor upon request by the Company.

30. NOTICE AND DISCLAIMER REGARDING FUTURE TARIFF MODIFICATIONS.

- A. This Contract shall, at all times, be subject to modification by the Commission as said Commission may, from time to time, direct in the exercise of its jurisdiction. Without limiting the foregoing, Subscriber Organization expressly acknowledges the following:
1. The CBRE Tariff is subject to modification by the Commission.
 2. The CBRE Facility shall be subject to any future modifications ordered by the Commission. Subscriber Organization agrees to abide by and comply with and to pay for any costs related to such Commission-ordered modifications for the term of the Contract.
- B. **BY SIGNING BELOW, SUBSCRIBER ORGANIZATION ACKNOWLEDGES IT HAS READ, UNDERSTANDS AND AGREES TO ABIDE BY THE ABOVE SECTION 30, NOTICE AND DISCLAIMER.**

IN WITNESS WHEREOF, the Parties hereto have caused this Contract to be executed by their duly authorized representatives. This Contract is effective as of the Effective Date set forth above.

[Subscriber Organization]

Hawai'i Electric Light Company, Inc.
Maui Electric Company, Limited],
a Hawai'i corporation

By: _____

By: _____

Name: _____

Name: _____

Date: _____

Date: _____

MAILING ADDRESS [select as appropriate]

[Maui Electric Company, Ltd.

Attn: Renewable Energy Projects Division

P.O. Box 398

Kahului, HI 96733-6898]

[Hawai'i Electric Light Company, Inc.

Hilo:

Kona:

HELCO Engineering

HELCO Engineering

Attn: DER Program

Attn: DER Program

54 Halekauila Street

74-5519 Kaiwi Street

Hilo, HI 96720

Kailua Kona, HI 96740]

ATTACHMENT A

SCHEDULE OF DEFINED TERMS

For the purposes of this Contract, the following capitalized terms shall have the meanings set forth below:

"Acceptance Test": A test conducted by Subscriber Organization and witnessed by Company, within thirty (30) Days of completion of all Interconnection Facilities and in accordance with criteria and test procedures determined by Company to determine conformance with Attachment F (Facility Owned by Subscriber Organization) and in accordance with Good Engineering and Operating Practices. Attachment F-8 (Acceptance Test General Criteria) provides general criteria to be included in the written protocol for the Acceptance Test. Successful completion of the Acceptance Test shall be a condition precedent for the performance of the Control System Acceptance Test and the Commercial Operations Date.

"Active Power Control Interface": Shall have the meaning set forth in Section 1(g) (Active Power Control Interface) of Attachment F (Facility Owned by Subscriber Organization) of this Contract.

"Actual Output": The total quantity of electric energy (measured in kilowatt hours) produced by the CBRE Facility over a given time period and delivered to the Point of Interconnection, as measured by the Revenue Meter. "Actual Output" is the equivalent of "Net Energy."

"Allowed Capacity": Shall have the meaning set forth in Section 5(f) of Exhibit F-1 (Description of Generation and Battery Storage Facilities) to this Contract.

"Applicable Period Lump Sum Payment": For each applicable period, the total amount of Lump Sum Payment payable during such period, as such amount may be calculated and adjusted from time to time as set forth in Section 4.B (Lump Sum Payment) of this Contract and/or Section 3 (Calculation of Lump Sum Payment) of Attachment B to this Contract.

"Applicable NEP Verification Date": For the Initial OEPR, the Initial NEP Verification Date. For any Subsequent OEPR, the first Day of the calendar month following the calendar month during which there occurs the first anniversary of the event (e.g., completion of equipment replacement) which occasioned the preparation of such Subsequent OEPR.

"Baseline SO Payment": For each calendar month, the balance of the monthly Lump Sum Payment remaining after deducting the dollar value of all Bill Credits.

"Battery Energy Storage System" or "BESS": The battery energy storage system as described in Attachment F (Facility Owned by Subscriber Organization) to the Contract, together with all other equipment, devices, and associated appurtenances owned, controlled, operated and managed by Subscriber Organization in connections, with or to facilitate, the storage, transmission, delivery or furnishing by Subscriber Organization to Company of the electric energy stored in the BESS.

"BESS Allocated Portion of the Lump Sum Payment": For each BESS Measurement Period and for any other applicable period, an amount equal to fifty percent (50%) of the total of the three monthly Lump Sum Payments for such period without taking into account any set-offs against such monthly Lump Sum Payments.

"BESS Annual Equivalent Availability Factor": Shall be as described in Attachment C, Section 4. (BESS Annual Equivalent Availability Factor) to this Contract.

"BESS Capacity Performance Metric": Shall have the meaning set forth in Attachment H, Section 1 (BESS Tests) to this Contract.

"BESS Capacity Cure Period": Shall have the meaning set forth in Attachment C, Section 3. (BESS Capacity Test; Liquidated Damages; Termination Rights).

"BESS Capacity Ratio": Shall have the meaning set forth in Attachment H (BESS Tests) to this Contract.

"BESS Capacity Test": Shall have the meaning set forth in Attachment H (BESS Tests) to this Contract.

"BESS Contract Capacity": The storage capacity, in MWh, of the BESS, or ___ MWh.

"BESS EAF Performance Metric": Shall have the meaning set forth in Attachment C Section 4. (BESS Annual Equivalent Availability Factor and Liquidated Damages).

"BESS EFOF Performance Metric": Shall have the meaning set forth in Attachment C Section 4. (BESS Annual Equivalent Forced Outage Factor; Liquidated Damages).

"BESS Measurement Period": Shall mean, in any Contract Year, the following periods of three calendar months each: (i) the period beginning on the first day of the first calendar month of such Contract Year and extending through the last day of the third calendar month of such Contract Year; (ii) the period beginning on the first day of the fourth calendar month of such Contract Year and extending through the last day of the sixth calendar month of such Contract Year; (iii) the period beginning on the first day of the seventh calendar month of such Contract Year and extending through the last day of the ninth calendar month of such Contract Year; and (iv) the period beginning on the first day of the tenth calendar month of such Contract Year and extending through the last day of the twelfth calendar month of such Contract Year.

"BESS Measurement Period Report": For each BESS Measurement Period, the report of the data necessary for calculation of the Performance Metrics for such BESS Measurement Period to be provided by Subscriber Organization to Company in the form set forth in Section 1 (Monthly Report) of Attachment E (Monthly Reporting and Dispute Resolution by Independent AF Evaluator) to this Contract or such other form as the Company may approve in writing.

"Bill Credit" shall mean the dollar amount credited by the Company to each Subscriber on the Subscriber's retail electric service bill, which represents the Subscriber's beneficial share of renewable energy produced by the CBRE Facility and exported to the Company, and offsetting Subscriber's current renewable energy usage on such service bill.

"Bill Credit Rate": shall mean the then current applicable "Credit Rate" as determined by the CBRE Tariff. The CBRE Tariff prescribes a specific Credit Rate in the event that CBRE Small Project Phase 2 Capacity (as defined in the CBRE Tariff) is not filled for any island and a competitive credit rate procurement ("CCRP") mechanism to set the Credit Rate if there are more applications for CBRE Small Project Phase 2 Capacity than is available for any island.

"Bill of Material": A list of equipment to be installed at the Facility including, but not necessarily limited to, items such as relays, breakers, and switches.

"Business Day": Any calendar day that is not a Saturday, a Sunday, or a federal or Hawai'i state holiday.

"CBRE Facility": Subscriber Organization's renewable electric energy facility that is the subject of this Contract, including the PV System, the BESS, all Subscriber Organization-Owned Interconnection Facilities and all other equipment, devices, associated appurtenances owned, controlled, operated and managed by Subscriber Organization in connection with, or to facilitate, the production, generation, storage, transmission, delivery or furnishing of electric energy by Subscriber Organization to Company and required to interconnect with the Company System.

"CBRE Framework" means the CBRE Framework (Phase 1), as amended and supplemented by the CBRE Framework (Phase 2).

"CBRE Framework (Phase 1)" means that certain "Community-Based Renewable Energy – A Program Framework" issued by the PUC and attached as Attachment A to that certain Decision and Order No. 35137, filed December 22, 2017, in Docket No. 2015-0389, portions of which are applicable to Phase 2 of the CBRE Program as specified in the CBRE Tariff.

"CBRE Framework (Phase 2)" means the framework CBRE Phase 2 established by the Commission pursuant to Order No. 37070, issued April 9, 2020, in Docket No. 2015-0389. The CBRE Framework (Phase 2) provides the basis and framework for Phase 2 of the CBRE Program and is implemented by the CBRE Tariff.

"CBRE IO" means the Independent Observer contracted with the Company but answering to the PUC to carry out the responsibilities assigned to the Independent Observer under the Phase 2 CBRE Framework.

"CBRE Online Portal" is the interactive, internet website-based interface maintained by or on behalf of the Company through which the Subscriber Organization may establish qualifications, provide information and complete documents necessary for acceptance in the CBRE Program, and may enter or change the Monthly Subscription Information reflecting updated information for each Subscriber, including any changes to any Subscriber's name, account number, address, and Subscriber Allocation. For Phase One of the CBRE Program, the CBRE Online Portal will be a manually administered application form-based process managed by Company until the CBRE Online Portal is online and ready for commercial operation. The CBRE Online Portal should be completed in time for the commencement of Phase Two of the CBRE Program.

"CBRE Program": The program established under the CBRE Tariff to allow developers of renewable energy projects to provide Account Holders with an opportunity to avail themselves of the benefits of the CBRE Tariff

"CBRE Project": A community-based renewable energy project subject to the CBRE Tariff.

"CBRE Tariff": The rules for Phase 2 of the CBRE Program approved by the PUC as Tariff Rule 29 based on the CBRE Framework (Phase 2).

"Commercial Operations": Upon satisfaction of the following conditions, the Facility shall be considered to have achieved Commercial Operations on the Day specified in Subscriber Organization's written notice described below: (i) the Acceptance Test has been passed, (ii) all generating units have passed Control System Acceptance Tests, (iii) the Transfer Date has occurred, (iv) Subscriber Organization has (1) provided to Company the Required Models (as defined in Section 6(a) (Subscriber Organization's Obligation to Provide Models) of Attachment F (Facility Owned by Subscriber Organization)) in the form of Source Code, (2) placed the current version of the Source Code for the Required Models with the Source Code Escrow Agent as required in Section 6(b)(i)(A) (Establishment of Source Code Escrow) of Attachment F (Facility Owned by Subscriber Organization), or (3) if Subscriber Organization is unable to arrange for the placement of the appropriate Source Code into the Source Code Escrow account, placed the required funds with the Monetary Escrow Agent as required in Section 6(b)(ii)(A) (Establishment of Monetary Escrow) of Attachment F (Facility Owned by Subscriber Organization), and (v) Subscriber Organization provides Company with written notice that (aa) Subscriber Organization is ready to declare the Commercial Operations Date and (bb) the Commercial Operations Date will occur within 24 hours (i.e., the next Day).

"Commercial Operations Date" or "COD": The date on which Facility first achieves Commercial Operations.

"Commercial Operations Date Deadline": Shall have the meaning set forth in Section 10.I.1 of this Contract.

"Company": Shall have the meaning set forth in the preamble to this Contract.

"Company-Designated NEP Estimate": The estimated Net Energy Potential of the CBRE Facility as designated by Company pursuant to Section 1.C. (NEP IE Estimate and Company-Designated NEP Estimate) of Attachment D (Calculation and Adjustment of Net Energy Potential) this Contract.

"Company Dispatch": Company's right, through supervisory equipment or otherwise, to direct or control both the capacity and the energy output of the CBRE Facility from its minimum output rating to its maximum output rating consistent with this Contract (including, without limitation, Good Engineering and Operating Practices, which dispatch shall include real power, reactive power, voltage, frequency, the determination to cycle a unit off-line or to restart a unit, the droop control setting, the ramp rate setting, and other characteristics of such electric energy output whose parameters are normally controlled or accounted for in a utility dispatching system.

"Company-Owned Interconnection Facilities": Shall have the meaning set forth in of Attachment G (Company-Owned Interconnection Facilities).

"Company System": The electric system owned and operated by Company (to include any non-utility owned facilities) consisting of power plants, transmission and distribution lines, and related equipment for the production and delivery of electric power to the public.

"Company System Operator": The authorized representative of Company who is responsible for carrying out Company dispatch and curtailment of electric energy generation interconnected to the Company System.

"Company's Recommendations": Shall have the meaning set forth in Section 4(c) of Attachment F (Facility Owned by Subscriber Organization) to this Contract.

"Competitive Bidding Framework": The Framework for Competitive Bidding contained in Decision and Order No. 23121 issued by the Public Utilities Commission on December 8, 2006, and any subsequent orders providing for modifications from those set forth in Order No. 23121 issued December 8, 2006.

"Consultants List": Shall have the meaning set forth in Exhibit F-2 (Consultants List) of Attachment F (Facility Owned by Subscriber Organization) to this Contract.

"Contract Capacity": Shall have the meaning set forth in Attachment F - Exhibit F-1 (Description of Generation and Battery Storage Facilities) to this Contract.

"Contract Year": A twelve (12) calendar month period commencing on either: (i) the Commercial Operations Date (if the Commercial Operations Date occurs on the first Day of a calendar month) and thereafter on each anniversary of the Commercial Operations Date; or (ii) the first Day of the calendar month following the month during which the Commercial Operations Date occurs, and thereafter on each anniversary of the first Day of such month; provided, however, that, in the latter case, the initial Contract Year shall also include the Days from the Commercial Operations Date to the first Day of the succeeding calendar month.

"Control System Acceptance Test(s)" or "CSAT": A test or tests performed on the centralized and collective control systems and Active Power Control Interface of the CBRE Facility, which includes successful completion of the Control System Telemetry and Control List, in accordance with procedures set forth in Exhibit F-7 (Control System Acceptance Test Criteria) to Attachment F (Facility Owned by Subscriber Organization) of the Contract.

"Control System Telemetry and Control List": The Control System Telemetry and Control List includes, but is not limited to, all of the Facility's equipment and generation performance/quality parameters that will be monitored, alarmed and/or controlled by Company's Energy Management System (EMS) throughout the Term of this Contract.

Examples of the Control System Telemetry and Control List include:

Subscriber Organization's substation/equipment status – breaker open/closed status, equipment normal/alarm operating status, etc.

Subscriber Organization's generation data (analog values) – number of generators available/online, voltage, current, MW, MVAR, etc.

Subscriber Organization's generation performance (status and/or analog values) – ramp rate, generator frequency, etc.

Active Power control interface – dispatch MW setpoint, etc.

Voltage control interface – voltage kV setpoint, etc.

Power factor control interface – power factor setpoint, etc.

"Day": A calendar day.

"Disconnection Event": Shall have the meaning set forth in Section 4(a) of Attachment F (Facility Owned by Subscriber Organization) to this Contract.

"Dispute": Shall have the meaning set forth in Section 17, of this Contract.

"DPR": Shall have the meaning set forth in Section 17, of this Contract.

"EMS" or "Energy Management System": The real-time, computer-based control system, or any successor thereto, used by Company to manage the supply and delivery of electric energy to its consumers. It provides the Company System Operator with an integrated set of manual and automatic functions necessary for the operation of the Company System under both normal and emergency conditions. The EMS provides the interfaces for the Company System Operator to perform real-time monitoring and control of the Company System, including but not limited to monitoring and control of the Facility for system balancing, supplemental frequency control and economic dispatch as prescribed in this Contract.

"Enhanced Residential Threshold": A specific percentage of Contract Capacity in excess of 40% committed to by Subscriber Organization in its proposal as the percentage to be represented by Subscriber Allocations for Residential Subscribers. The Enhanced Residential Threshold for this Contract is __%. [**Drafting note: If there is no Enhanced Residential Threshold enter "N/A" in the blank.**]

"Environment": Shall have the meaning set forth in Section 1(b) (iii) (G) (iii) (Malware) of Attachment F (Facility Owned by Subscriber Organization) to this Contract.

"Environmental Credits": Any environmental credit, offset, or other benefit allocated, assigned or otherwise awarded by any Governmental Authority, international agency, or non-governmental renewable energy certificate accounting and verification organization to Company or Subscriber Organization based in whole or in part on the fact that the CBRE Facility is a non-fossil fuel facility. Such Environmental Credits shall include, without limitation, the non-energy attributes of renewable energy including, but not limited to, any avoided emissions of pollutants to the air, soil, or water such as sulfur dioxide, nitrogen oxides, carbon monoxide, particulate matter, and hazardous air pollutants; any other pollutant that is now or may in the future be regulated under the pollution control laws of the United States; and avoided emissions of carbon dioxide and any other greenhouse gas, along with the renewable energy certificate reporting rights to these avoided emissions, but in all cases shall not mean tax credits.

"Event of Default": Shall have the meaning set forth in Section 13. (Events of Default by Subscriber Organization) of this Contract.

"Excess Energy Conditions": An operating condition on the Company System that may occur when Company has more energy available than is required to meet the load on the Company System at any point in time and the generating assets interconnected with the Company System are operating at or near their minimum levels, taking into consideration factors such as the need to maintain system reliability and stability under changing system conditions and configurations, the need for downward regulating reserves, the terms and conditions of power purchase Contracts for base-loaded firm capacity or scheduled energy, and the normal minimum loading levels of such units.

"Execution Date": The date designated as such on the first page of this Contract or, if no date is so designated, the date the Parties exchanged executed signature pages to this Contract.

"Facility's CBRE Program": The program offered by Subscriber Organization whereby Subscribers are afforded the opportunity to obtain benefits of the CBRE Tariff by acquiring a beneficial interest in the Contract Capacity by which renewable energy is produced by the Facility and exported to Company. The Facility's CBRE Program includes the entire process of marketing and sales of, or subscriptions to, the Subscriber Allocations, enrolling Subscribers, providing Company with the information necessary to afford each Subscriber the Bill Credit to which such Subscriber is entitled, responding to Subscriber inquiries, facilitating the transfer of Subscriber interests and buying back Subscriber interests. The Facility's CBRE Program shall have a duration of 20 years commencing on the Commercial Operations Date.

"Federal Non-Refundable Tax Credit": Shall mean any U.S. federal tax credit for which the federal government is not required to refund any tax credit which exceeds the tax payments due to the federal government by the Claiming Entity or to provide a cash rebate in lieu of such credit to the Claiming Entity.

"Federal Refundable Tax Credit": Shall mean any U.S. federal tax credit for which the federal government is required to refund any tax credit which exceeds the tax payments due to the federal government by the Claiming Entity or to provide a cash rebate in lieu of such credit to the Claiming Entity.

"First Benchmark Period": The period commencing on the Commercial Operations Date and ending on the last Day of the calendar month during which an OEPR Evaluator issues the Initial OEPR. During the First Benchmark Period, the First NEP Benchmark shall be the estimate of Net Energy Potential that is used to calculate the Lump Sum Payment as provided in Section 3.A. (Lump Sum Payment During First Benchmark Period) of Attachment B (Company Payments for Energy, Dispatchability and Availability of BESS) to this Contract.

"First NEP Benchmark": The estimate of Net Energy Potential that is used to calculate the Lump Sum Payment during the First Benchmark Period as provided in Section 3.A. (Lump Sum Payment During First Benchmark Period) of Attachment B (Company Payments for Energy, Dispatchability and Availability of BESS) to this Contract. The "First NEP Benchmark" shall consist of whichever of the following is applicable as of the Commercial Operation Date, as more fully provided in Section 1.C. (NEP IE Estimate and Company-Designated NEP Estimate) and Section 1.D. (NEP IE Estimate, Liquidated Damages and Subscriber Organization's Null and Void Right) of Attachment D (Calculation and Adjustment of Net Energy Potential) to this Contract: (i) NEP RFP Projection, (ii) NEP IE Estimate, (iii) Company-Designated NEP Estimate or (iv) such other amount as the Parties may agree in writing.

"First OEPR": Shall have the meaning set forth in Section 2.F. (Timeline and Fees) of Attachment D (Calculation and Adjustment of Net Energy Potential) to this Contract.

"Force Majeure": An event that satisfies the requirements of Section 27.A. (Definition of Force Majeure), Section 27.B. (Events That Could Qualify as Force Majeure) and Section 27.C. (Exclusions from Force Majeure).

"Forced Outage": A start failure or unplanned outage reported consistently with the principles in the NERC GADS REPORTING INSTRUCTIONS for SF, U1, U2 and U2 events. This may be a startup failure, a condition resulting in immediate shutdown or trip, or an outage which requires removal from the in-service state before the end of the next weekend (Sunday at 2400 or before Sunday turns into Monday). This type of outage can only occur while the resource is in service.

"Full Dispatch": A time period during which all inverters are available and there are no technical restrictions or limitations affecting generation imposed to meet Company Dispatch.

"Good Engineering and Operating Practices": The practices, methods and acts engaged in or approved by a significant portion of the electric utility industry for similarly situated U.S. facilities, considering Company's isolated island setting, that at a particular time, in the exercise of reasonable judgment in light of the facts known or that reasonably should be known at the time a decision is made, would be expected to accomplish the desired result in a manner consistent with law, regulation, reliability for an island system, safety, environmental protection, economy and expedition. With respect to the CBRE Facility, Good Engineering and Operating Practices include, but are not limited to, taking reasonable steps to ensure that:

Adequate materials, resources and supplies, are available to meet the CBRE Facility's needs under normal conditions and reasonably foreseeable abnormal conditions.

Sufficient operating personnel are available and are adequately experienced and trained to operate the CBRE Facility properly, efficiently and within manufacturer's guidelines and specifications and are capable of responding to emergency conditions.

Preventive, routine and non-routine maintenance and repairs are performed on a basis that ensures reliable long-term and safe operation, and are performed by knowledgeable, trained and experienced personnel utilizing proper equipment, tools, and procedures.

Appropriate monitoring and testing is done to ensure equipment is functioning as designed and to provide assurance that equipment will function properly under both normal and reasonably foreseeable abnormal conditions.

Equipment is operated in a manner safe to workers, the general public and the environment and in accordance with equipment manufacturer's specifications, including, without limitation, defined limitations such as temperature, current, frequency, polarity, synchronization, control system limits, etc.

"Governmental Approvals": All permits, licenses, approvals, certificates, entitlements and other authorizations issued by Governmental Authorities, as well as any agreements with Governmental Authorities, required for the construction, ownership, operation and maintenance of the CBRE Facility and the Company-Owned Interconnection Facilities, and all amendments, modifications, supplements, general conditions and addenda thereto.

"Governmental Authority": Any federal, state, local or municipal governmental body; any governmental, quasi-governmental, regulatory or administrative agency, commission, body or other authority exercising or entitled to exercise any administrative, executive, judicial, legislative, policy, regulatory or taxing authority or power; or any court or governmental tribunal.

"GPR": Shall have the meaning set forth in Section 3.C. (Assurance of Capability of CBRE Facility to Deliver Net Energy Potential and Availability of BESS) of this Contract.

"GPR Performance Metric": Shall be as determined under Attachment C, Section 1.B. (Determination of GPR Performance Metric) of this Contract.

"Hawai'i Investment Tax Credit": Shall mean a credit against Hawai'i source income for which Subscriber Organization is eligible on the Commercial Operations Date or thereafter because of investment in renewable energy technologies incorporated into the CBRE Facility.

"Hawai'i Non-Refundable Tax Credit": Shall mean any Hawai'i Investment Tax Credit for which the State of Hawai'i is not required to refund any tax credit which exceeds the tax payments due to the State of Hawai'i by the Claiming Entity or to provide a cash rebate in lieu of such credit to the Claiming Entity.

"Hawai'i Production Tax Credit": Shall mean a credit against Hawai'i source income for which Subscriber Organization is eligible on the Commercial Operations Date or thereafter because of the energy produced by the CBRE Facility.

"Hawai'i Refundable Tax Credit": Shall mean any Hawai'i Investment Tax Credit for which the State of Hawai'i is required to refund any tax credit which exceeds the tax payments due to the State of Hawai'i by the Claiming Entity or to provide a cash rebate in lieu of such credit to the Claiming Entity.

"Hawai'i Renewable Energy Tax Credit": The Hawai'i Investment Tax Credit and the Hawai'i Production Tax Credit.

"HERA": The Hawai'i Electricity Reliability Administrator.

"HERA Law": Act 166 (Haw. Leg. 2012), which was passed by the 27th Hawai'i Legislature in the form of S.B. No. 2787, S.D. 2, H.D.2, C.D.1 on May 2, 2012 and signed by the Governor on June 27, 2012. The effective date for the law is July 1, 2012. The HERA Law authorizes (i) the PUC to develop, adopt, and enforce reliability standards and interconnection requirements, (ii) the PUC to contract for the performance of related duties with a party that will serve as the HERA, and (iii) the collection of a Hawai'i electricity reliability surcharge to be collected by Hawai'i's electric utilities and used by the HERA. Reliability standards and interconnection requirements adopted by the PUC pursuant to the HERA Law will apply to any electric utility and any user, owner, or operator of the Hawai'i electric system. The PUC also is provided with the authority to monitor and compel the production of data, files, maps, reports, or any other information concerning any electric utility, any user, owner or operator of the Hawai'i electric system, or other person, business, or entity, considered by the commission to be necessary for exercising jurisdiction over interconnection to the Hawai'i electric system, or for administering the process for interconnection to the Hawai'i electric system.

"House Power" shall mean the electricity needed to assist in the operation of the CBRE Facility including system performance monitoring and associated communications, except for energy directly required for the local control and safe operation of the PV System and BESS. It also means other electricity used by the CBRE Facility, such as for perimeter lighting, a visitor's center or any other structures or facilities at the CBRE Facility site.

"Independent AF Evaluator": A person empowered, pursuant to Section 2(e) (Appointment of Independent AF Evaluator) of Attachment E (Monthly Reporting and Dispute Resolution by Independent AF Evaluator) to resolve disagreements due to failure of the Parties to resolve a Monthly Report Disagreement.

"Initial NEP OEPR Estimate": The NEP OEPR Estimate set forth in or derived from the Initial OEPR, as more fully set forth in Section 2.E (Terms of Engagement) of Attachment D (Calculation and Adjustment of Net Energy Potential) to this Contract.

"Initial NEP Verification Date": The first Day of the calendar month following the fifteenth (15th) calendar month after the Commercial Operations Date.

"Initial OEPR": The OEPR to be prepared pursuant in Section 1.E. (Initial OEPR) of Attachment D (Calculation and Adjustment of Net Energy Potential) to this Contract.

"Interconnection Facilities": The equipment and devices required to permit the CBRE Facility to operate in parallel with, and deliver electric energy to, the Company System and provide reliable and safe operation of, and power quality on, the Company System (in accordance with applicable provisions of the PUC's General Order No. 7, Company tariffs, operational practices, interconnection requirements studies, and planning criteria), such as, but not limited to, transmission and distribution lines, transformers, switches, and circuit breakers.

"Interconnection Requirements Study" or "IRS": A study consisting of a system impact study and a Facility study, performed in accordance with the terms of the IRS Letter Agreement to determine, among other things, (a) the system requirements and equipment requirements to interconnect the CBRE Facility with the Company System, (b) the Performance Standards for the CBRE Facility, and (c) an estimate of interconnection costs and project schedule for interconnection of the CBRE Facility.

"IRS Amendment": Shall have the meaning ascribed to such term in Section 3.C.1 (Interconnection Requirements Study).

"IRS Amendment Deadline": The 75th Day following the date the completed IRS is provided to Subscriber Organization, or such later date as Company and Subscriber Organization may agree to by written agreement.

"IRS Letter Agreement or IRS Letter Agreements": The system impact study and Facility study letter agreements (which may combined into one letter agreement) and any written, signed amendments thereto, between Company and Subscriber Organization that collectively describe the scope, schedule, and payment arrangements for the Interconnection Requirements Study.

"IRS Termination Deadline:" The 30th Day following the date the completed IRS is provided to Subscriber Organization, or such later date as Company and Subscriber Organization may agree to by a written agreement.

"Interface Block Diagram": The visual representation of the signals between Subscriber Organization and Company, including but not limited to, Telemetry and Control points, digital fault recorder settings, telecommunications and protection signals.

"kV": Kilovolt.

"kW": Kilowatt. Unless expressly provided otherwise, all kW values stated in this Contract are alternating current values and not direct current values.

"kWh": Kilowatt-hour.

"Land Rights": All easements, rights of way, licenses, leases, surface use agreements and other interests or rights in real estate.

"Laws": All federal, state and local laws, rules, regulations, orders, ordinances, permit conditions and other governmental actions.

"LD Assessment Date": For the last month of each LD Period, the Day following the expiration of the 10-Business Day period provided for Company to submit a Notice of Disagreement pursuant to Section 2(a) (Notice of Disagreement With Monthly Report) of Attachment E (Monthly Reporting and Dispute Resolution by Independent AF Evaluator) to this Contract.

"LDT": Shall have the meaning set forth in Attachment C, Section 6.A. (RTE Test and Liquidated Damages).

"LMI Minimum Threshold": A specific percentage of Contract Capacity committed to by Subscriber Organization in its proposal as the percentage to be represented by Subscriber Allocations for LMI Subscribers. The Minimum LMI Threshold for this Contract is __%. [Drafting note: The percentage shall be taken from Subscriber Organization's proposal if that proposal included a LMI Minimum Threshold. If there is no LMI Minimum Threshold enter "N/A" in the blank. For dedicated LMI projects, the LMI Minimum Threshold is 100%.]

"LMI Subscriber": A Subscriber who satisfies the LMI requirements set forth in the CBRE Tariff.

"LD Period": A rolling period of twelve (12) calendar months each. At the end of each calendar month, the LD Period rolls forward to include the next calendar month. The initial "LD Period" shall consist of the 12 full calendar months of the initial Contract Year.

"Losses": Any and all direct, indirect or consequential damages, fines, penalties, deficiencies, losses, liabilities (including settlements and judgments), costs, expenses (including reasonable attorneys' fees and court costs) and disbursements.

"Lowest BESS Capacity Bandwidth": Shall have the meaning set forth in Attachment C Section 3. (BESS Capacity Test; Liquidated Damages; Termination Rights).

"Lump Sum Payment": The monthly lump sum as provided in Section 2. (Lump Sum Payment for Purchase of Dispatchability) of Attachment B to this Contract (Company Payments for Energy, Dispatchability and Availability of BESS).

"Malware": means computer software, code or instructions that: (a) intentionally, and with malice intent by a third party, adversely affect the operation, security or integrity of a computing, telecommunications or other digital operating or processing system or environment, including without limitation, other programs, data, databases, computer libraries and computer and communications equipment, by altering, destroying, disrupting or inhibiting such operation, security or integrity; (b) without functional purpose, self-replicate without manual intervention; (c) purport to perform a useful function but which actually performs either a destructive or harmful function, or perform no useful function other than utilize substantial computer, telecommunications or memory resources with the intent of causing harm; or (d) without authorization collect and/or transmit to third parties any information or data; including such software, code or instructions commonly known as viruses, Trojans, logic bombs, worms, adware and spyware.

"Management Meeting": Shall have the meaning set forth in Section 17.B. (Dispute Resolution).

"Maximum Rated Output": Net maximum output of the BESS in MW, which shall not exceed the Allowed Capacity.

"Measured Performance Ratio" or "MPR": Shall have the meaning set forth in Attachment C, Section 2.A. (Calculation of Measured Performance Ratio) of this Contract.

"Monthly Progress Report": Shall have the meaning set forth in Attachment E (Monthly Progress Report).

"Monthly Report": The report of the data (for the calendar month and the LD Period, the MPR Assessment Period and the BESS Measurement Period ending with such calendar month) necessary for the calculation of the Performance

Metrics to be provided by Subscriber Organization to Company as set forth in Section 1. (Monthly Report) of Attachment E (Monthly Reporting and Dispute Resolution by Independent AF Evaluator) to this Contract. Without limitation to the generality of the preceding sentence, references to the Monthly Report for a month that constitutes the last month of a BESS Measurement Period shall be deemed to include the BESS Measurement Period Report for such BESS Measurement Period.

"Monthly Report Disagreement": Any disagreement arising out of the same Monthly Report.

"Monthly Subscription Information" shall mean the information stored within the CBRE Online Portal, as timely entered or changed by the Subscriber Organization via the CBRE Online Portal, setting forth the name, account number and service address each Subscriber holding subscriptions in the CBRE Facility, and the Subscriber Allocation applicable to each such Subscriber's subscription, reflecting each Subscriber's allocable portion of renewable energy produced by the CBRE Facility during a particular Production Month.

"Most Recent Prior NEP Benchmark": In the event a Subsequent OEPR is prepared for an OEPR Period of Record ending on or after the commencement of the fourth (4th) Contract Year, the "Most Recent Prior NEP Benchmark" shall be (i) for the first such Subsequent OEPR, the Second NEP Benchmark that was used to calculate the Lump Sum Payment for the last month of the Second Benchmark Period pursuant to Section 3.B. of Attachment B (Company Payments for Energy, Dispatchability and Availability of BESS) to this Contract and (ii) for all Subsequent OEPRs prepared after the aforementioned first Subsequent OEPR, the NEP OEPR Estimate obtained from the immediately preceding Subsequent OEPR.

"MPR": Shall have the meaning set forth in Attachment C Section 2. of this Contract.

"MPR Assessment Period": Shall mean, for purposes of demonstrating a Measured Performance Ratio, a rolling period of twelve (12) calendar months each. At the end of each calendar month, the MPR Assessment Period rolls forward to include the next calendar month. The initial "MPR Assessment Period" shall consist of the 12 full calendar months of the initial contract year.

"MPR Assessment Period Lump Sum Payment": For each MPR Assessment Period, the monthly Lump Sum Payment for the twelfth month of such MPR Assessment Period after deducting the amounts (if any) payable as liquidated damages under Attachment C Section 1. (PV System Equivalent Availability Factor Performance Metric and Liquidated Damages) for the same calendar month in question.

"MPR Test": Shall have the meaning set forth in Attachment C, Section 2.B. (MPR Test) of this Contract.

"MW": Megawatt. Unless expressly provided otherwise, all MW values stated in this Contract are alternating current values and not direct current values.

"MWh": Megawatt-hour.

"NEP IE Estimate": The estimated Net Energy Potential of the CBRE Facility to which the IE Energy Assessment Report assigns a P-Value of 95 for a ten-year period.

"NEP OEPR Estimate": For each OEPR, the estimated Net Energy Potential of the CBRE Facility to which such OEPR assigns a P-Value of 95 for a ten-year period.

"NEP RFP Projection": The Net Energy Potential of the CBRE Facility to which the Subscriber Organization in Subscriber Organization's RFP Proposal assigns a P-Value of 95 for a ten-year period.

"NERC GADS": Shall have the meaning set forth in Section 4.C. (Assurance of Capability of CBRE Facility to Deliver Net Energy Potential and Availability of BESS) of this Contract.

"Net Amount": Shall mean, with respect to any Hawai'i Renewable Tax Credit, the amount remaining after deducting any documented and reasonable financial, legal, administrative and other costs and expenses of applying for, pursuing, monetizing and receiving the applicable Hawai'i Renewable Tax Credit, payments by (or reserves established for the

payment by) Subscriber Organization and/or its investors on account of federal or state income taxes (at the highest applicable marginal corporate rate) payable with respect to receipt of such Hawai'i Renewable Tax Credit, and all payments to or reserves required by Subscriber Organization's lenders or other financing parties in connection with the application for or receipt of such Hawai'i Renewable Tax Credit.

"Net Energy": The total quantity of electric energy (measured in kilowatt hours) produced by the CBRE Facility over a given time period and delivered to the Point of Interconnection, as measured by the Revenue Meter. "Net Energy" the equivalent of "Actual Output."

"Net Energy Potential": The estimated single number with a P-Value of 95 for the annual Net Energy that could be produced by the CBRE Facility based on the estimated long-term monthly and annual total of such production over a ten-year period. The Net Energy Potential is subject to adjustment as provided in Attachment D (Calculation and Adjustment of Net Energy Potential) to this Contract, but in no circumstances shall the Net Energy Potential exceed the NEP RFP Projection.

"Notice of Disagreement": Shall have the meaning set forth in Section 2(a) (Notice of Disagreement with Monthly Report) of Attachment E (Monthly Reporting and Dispute Resolution by Independent AF Evaluator) to this Contract.

"OEPR": An Operational Energy Production Report, including the Initial OEPR and each Subsequent OEPR.

"OEPR Conference": Shall have the meaning set forth in Section 2.G. (Review of the First OEPR Evaluator Report) of this Attachment D (Calculation and Adjustment of Net Energy Potential) to this Contract.

"OEPR Consultants List": The engineering firms listed in Section 2.J. (Acceptable Persons and Entities) of Attachment D (Calculation and Adjustment of Net Energy Potential) to this Contract, as such list may be expanded or contracted by the Parties as provided in Section 2.B. (Eligibility for Appointment as OEPR Evaluator) of said Attachment D (Calculation and Adjustment of Net Energy Potential) or Section 2.(f) (Eligibility for Appointment as Independent AF Evaluator) of Attachment E (Monthly Reporting and Dispute Resolution by Independent AF Evaluator) to this Contract.

"OEPR Evaluator": Shall have the meaning set forth in Section 4(a) (Selection of OEPR Evaluator) of Attachment D (Calculation and Adjustment of Net Energy Potential) of this Contract.

"OEPR Period of Record": For each OEPR, the twelve-month period preceding the Applicable NEP Verification Date for such OEPR.

"Parties": Subscriber Organization and Company, collectively.

"Party": Each of Subscriber Organization or Company.

"Performance Metrics": Each of the applicable PV System Equivalent Availability Factor Performance Metric, the GPR Performance Metric, the BESS Capacity Performance Metric, the BESS EAF Performance Metric, the BESS EFOF Performance Metric, and the RTE Performance Metric.

"Performance Metrics LDs": Shall have the meaning set forth in Attachment C Section 8. (Payment of Liquidated Damages for Failure to Achieve Performance Metrics; Limitation on Liquidated Damage).

"Performance Standards": The various performance standards for the operation of the Facility and the delivery of electric energy from the Facility to Company specified in Section 3. (Performance Standards) of Attachment F (Facility Owned by Subscriber Organization), as such standards may be revised from time to time pursuant to this Contract.

"Point of Interconnection": The point of delivery of electric energy and/or capacity supplied by Subscriber Organization to Company, where the CBRE Facility owned by the Subscriber Organization interconnects with the Company System. The Subscriber Organization shall own and maintain the facilities from the CBRE Facility to the Point of Interconnection, excluding any Company-Owned Interconnection Facilities located on the Site. The Company shall own and maintain the facilities from the Point of Interconnection to the Company's system. The Point of

Interconnection will be identified in the IRS and set forth on the Single-Line Drawing and Interface Block Diagram in Attachment F, Exhibit F-5 (Single-Line Drawing and Interface Block Diagram).

"Prime Rate" shall mean the current "U.S. Prime Rate" of interest, as published from time to time by The Wall Street Journal in the "Money Rates" section of its Western Edition Newspaper. The Prime Rate shall change without notice with each change in the U.S. Prime Rate reported by The Wall Street Journal, as of the date such change is reported.

"Project": The Facility as described in Attachment F (Facility Owned by Subscriber Organization).

"Project Documents": This Contract, any ground lease or other agreement or instrument in respect of the Site and/or the Land Rights, all construction contracts to which Subscriber Organization is or becomes a party thereto, operation and maintenance agreements, and all other agreements, documents and instruments to which Subscriber Organization is or becomes a party thereto in respect of the Facility, other than the Financing Documents, as the same may be modified or amended from time to time in accordance with the terms thereof.

"PUC": Shall have the meaning set forth in the Recitals.

"PUC's Standards": Standards for Small Power Production and Cogeneration in the State of Hawai'i, issued by the Public Utilities Commission of the State of Hawai'i, Chapter 74 of Title 6, Hawai'i Administrative Rules, currently in effect and as may be amended from time to time.

"PV System": The photovoltaic solar electric generating project as more particularly described in Exhibit F-1 to Attachment F to the Contract (Description of Generation and Battery Storage Facilities).

"PV System Equivalent Availability Factor Performance Metric": Shall have the meaning set forth in Attachment C, (Required Performance Metrics; Liquidated Damages).

"Renewable Portfolio Standards" or "RPS": The Hawai'i law that mandates that Company and its subsidiaries generate or purchase certain amounts of their net electricity sales over time from qualified renewable resources. The RPS requirements in Hawai'i are currently codified as Hawai'i Revised Statutes (HRS) 269-91 through 269-95.

"Renewable Resource Baseline": The estimated renewable resource potential of the Site for a typical meteorological year. For avoidance of doubt, the purpose of this term is to provide a short-hand characterization of the nature of the renewable resource risk assumed by the Subscriber Organization under this Contract in making its Site selection.

"Renewable Resource Variability": The variations, above and below the Renewable Resource Baseline, of the renewable resource actually available at the Site on a moment-to-moment basis. For avoidance of doubt, the purpose of this term is to provide a short-hand characterization of the nature of the renewable resource risk assumed by the Company under this Contract in agreeing to make fixed payments in an amount calculated on the basis of the CBRE Facility's capability to deliver the Net Energy Potential regardless of whether or not sufficient renewable resource is in fact available at any particular moment.

"Revenue Meter": The revenue meter packaging, revenue metering PTs and CTs, and secondary wiring, which will record the renewable energy produced by the CBRE Facility and dispatched to the Company at the Point of Interconnection.

"RFP": Company's Request for Proposals issued on [_____], 202_.

"RFP Proposal": The documents and submissions comprising Subscriber Organization's proposal selected in response to the RFP.

"RTE Performance Metric": Shall have the meaning set forth in Attachment H, Section 1 (BESS Tests) to this Contract.

"RTE Ratio": Shall have the meaning set forth in in Section 1 (BESS Tests) of Attachment H to this Contract.

"SCADA" or "Supervisory Control and Data Acquisition": The Company system that provides remote control and monitoring of Company's transmission and sub-transmission systems and enables Company to perform real-time control of equipment in the field and to monitor the conditions and status of the Company System.

"Second Benchmark Period": The period commencing on the first Day of the calendar month following the month during which an OEPR Evaluator issues the Initial OEPR and ending with the expiration of the third (3rd) Contract Year. For avoidance of doubt, the effect of the foregoing definition is that the Second Benchmark Period will follow immediately upon the expiration of the First Benchmark Period.

"Second NEP Benchmark": For each calendar month during the Second Benchmark Period, the estimate of Net Energy Potential to be used during such calendar month to calculate the Lump Sum Payment pursuant to Section 3. (Calculation of Lump Sum Payment) of Attachment B (Company Payments for Energy, Dispatchability and Availability of BESS) to this Contract. For avoidance of doubt, the Second NEP Benchmark may vary during the Second Benchmark Period as and to the extent provided in Section 3.B. of Attachment B (Company Payments for Energy, Dispatchability and Availability of BESS) to this Contract.

"Second OEPR": Shall have the meaning set forth in Section 2.G. (Review of the First OEPR Evaluator Report) of Attachment D (Calculation and Adjustment of Net Energy Potential) to this Contract.

"Second OEPR Evaluator": Shall have the meaning set forth in Section 2.G. (Review of the First OEPR Evaluator Report) of Attachment D (Calculation and Adjustment of Net Energy Potential) to this Contract.

"Site": The parcel of real property on which the CBRE Facility will be constructed and located, together with any Land Rights reasonably necessary for the construction, ownership, operation and maintenance of the CBRE Facility. The Site is identified in Attachment F (Facility Owned by Subscriber Organization) to this Contract.

"Source Code": Shall mean the human readable source code of the Required Models which: (i) will be narrated documentation related to the compilation, linking, packaging and platform requirements and any other materials or software sufficient to enable a reasonably skilled programmer to build, modify and use the code within a commercially reasonable period of time for the purposes of a Source Code Authorized Use; and (ii) can reasonably be compiled by a computer for execution.

"Source Code Authorized Use": Shall have the meaning set forth in Section 6(b) (i) (E) (Authorized Use) of Attachment F (Facility Owned by Subscriber Organization) of this Contract.

"Source Code Escrow": Shall mean the escrow established with the Source Code Escrow Agent under the terms of the Source Code Escrow Agreement under which Source Code shall be confidentially deposited by a Source Code Owner for safekeeping and, upon the satisfaction of certain conditions, release to the Company.

"Source Code Escrow Agent": Shall mean Iron Mountain Intellectual Property Management, Inc. or such other similar escrow agent approved by Company.

"Source Code Escrow Agreement": Shall mean a multi-party escrow agreement between Company, Source Code Escrow Agent and any and all Source Code Owners depositing Source Code into the Source Code Escrow which, among other matters, names Company as beneficiary thereunder, and is otherwise acceptable in form and substance to Company.

"Source Code Owner": Shall mean the developer and/or owner of the Required Models utilizing Source Code authorized to deposit the Source Code with the Source Code Escrow Agent upon the terms of the Source Code Escrow Agreement.

"SOX 404": Shall have the meaning set forth in Section 8.F. (Financial Compliance) of the Contract.

"State of Charge": Energy in the BESS stated as a percentage of BESS Contract Capacity.

"Submission Notice": Shall have the meaning set forth in Section 2(e) (Appointment of Independent AF Evaluator) of Attachment E (Monthly Reporting and Dispute Resolution by Independent AF Evaluator) to this Contract.

"Study": Shall have the meaning set forth in Section 4(e) of Attachment F (Facility Owned by Subscriber Organization) to this Contract.

"Submission Notice": Shall have the meaning set forth in Section 2(e) (Appointment of Independent AF Evaluator) of Attachment E (Monthly Reporting and Dispute Resolution by Independent AF Evaluator) to this Contract.

"Subscriber" means a retail customer of the Company who owns one or more subscriptions of a CBRE Facility interconnected with the Company.

"Subscriber Agency Agreement and Consent Form" means the agreement between Subscriber Organization and Subscriber that authorizes disclosure of certain Account Information and Energy Usage Data, the form of which is included in the CBRE Tariff.

"Subscriber Agreement" means the written Agreement between Subscriber Organization and its Subscribers required to contain standard information and provisions to ensure transparency and proper consumer protection in accordance with the CBRE Tariff and applicable law.

"Subscriber Allocation" shall mean, for each Subscriber, such Subscriber's percentage interest in the total nameplate capacity of the PV System, reflecting each Subscriber's allocable portion of renewable energy available for dispatch by the CBRE Facility in a particular calendar month.

"Subscriber's Confidential Account Information" consists of the Subscriber's name, account number, service address, telephone number, email address, web site URL, information on Subscriber participation in other distributed generation serving the premises of the Subscriber, and Subscriber specific Bill Credit(s).

"Subscriber Organization": Shall have the meaning set forth in the preamble to this Contract.

"Subscriber Organization Affiliate": Shall have the meaning set forth in Section 6(b) (ii) (A) (Establishment of Monetary Escrow) of Attachment F (Facility Owned by Subscriber Organization) to this Contract.

"Subscriber Organization-Attributable Non-Generation": Time periods during which the inverter in question (or the CBRE Facility as a whole) is not dispatched or is derated or shutdown (or the CBRE Facility is disconnected) because of any of the following:

- (i) The CBRE Facility's failure to comply with any of the Performance Standards, Good Engineering and Operating Practices, Governmental Approvals, applicable Laws or Subscriber Organization's other obligations under this Contract;
- (ii) Subscriber Organization-Attributable System Conditions;
- (iii) Conditions at or on either side of the Point of Interconnection arising from the acts or omissions of Subscriber Organization or any of its affiliates, employees, agents, contractors, vendors, materialmen, independent contractors or suppliers of Subscriber Organization, acting in such capacity for the benefit of Subscriber Organization ("Subscriber Organization Representatives"), unless such acts or omissions are themselves excused by reasons of Force Majeure pursuant to Section 27. (Force Majeure) of the Contract;
- (iv) A disconnection initiated by the Company pursuant to Section 12. (Personnel and System Safety) of this Contract that is caused by Subscriber Organization or any Subscriber Organization Representatives;

- (v) The Company has reasonably decided that it is inadvisable for such WTG, inverter (or the CBRE Facility as a whole) to continue normal operations without a further Control System Acceptance Test as provided in Attachment F to the Contract;
- (vi) The CBRE Facility is deemed to be in Subscriber Organization-Attributable Non-Generation status under any of the following sections of Attachment F: Section 1(g) (vi), Section 1(j) (Demonstration of Facility) or Section 4(e);
- (vii) The CBRE Facility is shutdown at the direction of Company, and such shutdown is caused by Subscriber Organization or any Subscriber Organization Representatives or the lack of reliable real time data; and
- (viii) The CBRE Facility fails to comply with Company Dispatch or other outage or duration as provided in Section 5.C. (Company Rights of Dispatch)

Each time period of Subscriber Organization-Attributable Non-Generation shall constitute an Outage or Deration, as applicable.

"Subscriber Organization-Attributable System Conditions": Conditions on the Company System:

- (i) that result from either (a) the CBRE Facility's generation and delivery of electric power to the Company System or (b) any condition arising from the acts or omissions of Subscriber Organization or any Subscriber Organization Representative, unless such acts or omissions are themselves excused by reasons of Force Majeure pursuant to Section 27. of the Contract; and
- (ii) caused by or attributable to the CBRE Facility or Subscriber Organization or any Subscriber Organization Representatives that Company reasonably determines to either (a) be inconsistent with Good Engineering and Operating Practices on the Company System or (b) jeopardize the safety, reliability or stability of the Company System.

For avoidance of doubt, the Company's inability to dispatch the CBRE Facility due to the existence of Excess Energy Conditions on the Company System shall not constitute Subscriber Organization-Attributable System Conditions.

"Subscriber Organization-Owned Interconnection Facilities": The Interconnection Facilities constructed and owned by Subscriber Organization.

"Subscriber's Confidential Account Information" consists of the Subscriber's name, account number, service address, telephone number, email address, web site URL, information on Subscriber participation in other distributed generation serving the premises of the Subscriber, and Subscriber specific Bill Credit(s).

"Subscriber's Usage Data" refers to data collected from the utility Subscriber meters that reflects the quantity, quality, or timing of electric usage or renewable energy production attributable to the Subscriber for the service address and account number identified for participation in the CBRE Facility.

"Subsequent NEP OEPR Estimate": For each Subsequent OEPR, the NEP OEPR Estimate derived from such Subsequent OEPR.

"Subsequent OEPR": Any OEPR prepared pursuant to Section 1.F. (Subsequent OEPRs) of Attachment D (Calculation and Adjustment of Net Energy Potential) to this Contract.

"Subsequent NEP OEPR Estimate": For each Subsequent OEPR, the NEP OEPR Estimate derived from such Subsequent OEPR.

"Subsequent OEPR": Any OEPR prepared pursuant to Section 1.F. (Subsequent OEPRs) of Attachment D (Calculation and Adjustment of Net Energy Potential) to this Contract.

"Substantial Progress" means that on or before the last Day of the 18-month period (including day-for-day extensions) to achieve the Commercial Operations Date, the Subscriber Organization has achieved all of the following: (1) Installed one-hundred percent (100%) of the PV System foundation (including pier, helical screw, ballasts, or similar) to enable mounting of the nameplate capacity as collectively set forth in Attachment F to this Contract; (2) Built, or otherwise has in place, a permanent drivable (road) surface on the parcel or parcels of land associated with the CBRE Facility so that Company on a 24 hour a day, seven days a week, basis can access its equipment, including but not limited to lines, poles, transformers, billing meters, underground facilities and other facilities, but excluding production meters. The drivable road surface needs to be reasonably sufficient to support operation and maintenance vehicles; and (3) Built, or otherwise has in place, a permanent fence surrounding the entirety of the CBRE Facility location

"Telemetry and Control": The interface between Company's EMS and the physical equipment at the Facility.

"Term" means the term of this Contract and shall begin when this Contract is signed by the Parties and end twenty (20) years after the Commercial Operations Date unless otherwise provided for in this Contract.

"Termination Damages": Liquidated damages calculated in accordance with Section 15. (Damages in the Event of Termination by Company) of this Contract.

"Third OEPR": Shall have the meaning set forth in Section 2.H. (Review of the Second OEPR Evaluator Report) of Attachment D (Calculation and Adjustment of Net Energy Potential) to this Contract.

"Third OEPR Evaluator": Shall have the meaning set forth in Section 2.H. (Review of the Second OEPR Evaluator Report) of Attachment D (Calculation and Adjustment of Net Energy Potential) to this Contract.

"Third Party": Any person or entity other than Company or Subscriber Organization, and includes, but is not limited to, any subsidiary or affiliate of Subscriber Organization.

"Tier 1 Bandwidth": The Tier 1 bandwidth set forth in Attachment C, Section 2. C. (GPR Performance Metric and Liquidated Damages) of this Contract.

"Tier 2 Bandwidth": The Tier 2 bandwidth set forth in Attachment C, Section 2. C. (GPR Performance Metric and Liquidated Damages) of this Contract.

"Total Estimated Interconnection Costs": Shall have the meaning set forth in Section 11.E.3 of this Contract and as further described in Attachment G (Company-Owned Interconnection Facilities).

"Transfer Date": The date, prior to the Commercial Operations Date, upon which Subscriber Organization transfer to Company all right, title and interest in and to Company-Owned Interconnection Facilities to the extent, if any, that such facilities were constructed by Subscriber Organization and/or its contractors.

"Unit Price": \$ ___ per ___ MWh of Net Energy Potential annually. [TO BE CALCULATED FROM RESPONSE TO RFP.]

"Unsubscribed RDG": That portion of the Contract Capacity during a particular calendar month that is not associated with any Subscriber and is therefore not included in any Subscriber Allocation for such month. The Unsubscribed RDG for a particular calendar month is the balance of the Contract Capacity remaining.

--END--

ATTACHMENT B

COMPANY PAYMENTS FOR ENERGY, DISPATCHABILITY AND AVAILABILITY OF BESS

1. **PRICE FOR PURCHASE OF ELECTRIC ENERGY.** Commencing on the Commercial Operations Date, Company shall pay Subscriber Organization for electric energy produced by the Facility and delivered to the Point of Interconnection in response to Company Dispatch in accordance with this Contract at the rate of \$0.00/MWh. Company shall also not pay for electric energy delivered to the Point of Interconnection from the BESS.

2. **LUMP SUM PAYMENT.** Commencing on the Commercial Operations Date, Company shall pay for (i) the Actual Output produced by the Facility and delivered to the Point of Interconnection in response to Company Dispatch of the Facility; (ii) the availability of the Facility's Net Energy Potential for Company Dispatch in accordance with this Contract, and (iii) the BESS Services, a monthly Lump Sum Payment as calculated and adjusted as set forth in Section 3. (Calculation of Lump Sum Payment), below. The monthly Lump Sum Payment shall be calculated and adjusted to reflect changes in the estimate of the Facility's Net Energy Potential as such estimate is revised from time to time as more fully set forth in Attachment D. (Calculation and Adjustment of Net Energy Potential) to this Contract.

3. **CALCULATION OF LUMP SUM PAYMENT.** The monthly Lump Sum Payment shall be calculated and adjusted as follows:

A. **Lump Sum Payment during First Benchmark Period.** During the First Benchmark Period, the monthly Lump Sum Payment shall be equal to one-twelfth (1/12th) of the product (rounded to the nearest cent) obtained by multiplying the Unit Price by the First NEP Benchmark.

B. **Lump Sum Payment during Second Benchmark Period.**

1. One purpose of the Second Benchmark Period is to provide the Subscriber Organization, in the event that the Initial NEP OEPR Estimate is less than NEP RFP Projection, with a limited period during which Subscriber Organization will have an opportunity, by having a Subsequent OEPR prepared pursuant to Section 1.F.2. (Voluntary Subsequent OEPR) of Attachment D (Calculation Adjustment of Net Energy Potential) to this Contract, to obtain an adjustment to the NEP OEPR Estimate used to calculate the Lump Sum Payment, subject to (i) the cap on any upward adjustment imposed by the limitation that the estimate of Net Energy Potential that is used to calculate the Lump Sum Payment shall not exceed the NEP RFP Projection and (ii) the risk that any Subsequent OEPR might result in a downward adjustment to the NEP OEPR Estimate used to calculate the Lump Sum Payment. Accordingly, for each calendar month during the Second Benchmark Period, the monthly Lump Sum Payment shall be equal to one-twelfth (1/12th) of the product (rounded to the nearest cent) obtained by multiplying the Unit Price by the lesser of (w) the NEP RFP Projection or (x) the NEP OEPR Estimate of the OEPR that is most recent as of the first Day of such calendar month. For avoidance of doubt:

a. On the first Day of the Second Benchmark Period, the most recent OEPR will be the Initial OEPR;

b. If no Subsequent OEPR is issued under Section 1. F. (Subsequent OEPRs) of Attachment D (Calculation and Adjustment of Net Energy Potential) to this Contract for an OEPR Period of Record ending prior to the end of the third (3rd) Contract Year, the "most recent OEPR" during the entirety of the Second Benchmark Period will be the Initial OEPR;

c. If any Subsequent OEPR is prepared for an OEPR Period of Record ending prior to the commencement of the fourth (4th) Contract Year, the monthly Lump Sum Payment shall, for the period commencing on the first Day of the calendar month following the month during which an OEPR Evaluator issues such Subsequent OEPR, be equal to one-twelfth (1/12th) of the product (rounded to the nearest cent) obtained by multiplying the Unit Price by the lesser of (w) the NEP OEPR Estimate obtained from such Subsequent OEPR or (x) the NEP RFP Projection. The monthly Lump Sum

Payment calculated as aforesaid shall remain in effect through the first to occur of (y) the end of the Term or (z) the end of the calendar month during which an OEPR Evaluator issues the next Subsequent OEPR (if any) that is required or permitted under Section 2. (Preparation of OEPR) of Attachment D (Calculation and Adjustment of Net Energy Potential) to this Contract.

C. Lump Sum Payment Following Second Benchmark Period.

1. As of the first Day of the fourth (4th) Contract Year, the estimate of Net Energy Potential that was used to calculate the Lump Sum Payment for the last calendar month of the Second Benchmark Period shall continue in effect as the estimate of Net Energy Potential that is used to calculate the Lump Sum Payment until the end of the calendar month during which an OEPR Evaluator issues the first Subsequent OEPR for an OEPR Period of Record ending on or after the commencement of the fourth (4th) Contract Year and, effective at the end of such calendar month, the Second NEP Benchmark that was in effect immediately prior to the issuance of such Subsequent OEPR shall constitute the "Most Recent Prior NEP Benchmark" under clause (i) of the definition of that term set forth in this Contract. For avoidance of doubt, if no Subsequent OEPR is issued for an OEPR Period of Record ending on or after the commencement of the fourth (4th) Contract Year, the Second NEP Benchmark that was used to calculate the Lump Sum Payment for the last calendar month of the Second Benchmark Period shall continue in effect for the balance of the Term as the estimate of Net Energy Potential that is used to calculate the Lump Sum Payment.
2. In order to facilitate planning for the Company System, no increase in Net Energy Potential (and hence in the monthly Lump Sum Payment) shall be permitted under this Contract as a consequence of any Subsequent OEPR that is prepared for an OEPR Period of Record ending on or after the expiration of the Second Benchmark Period. Accordingly, if any such Subsequent OEPR is prepared, the monthly Lump Sum Payment shall, for the period commencing on the first Day of the calendar month following the month during which an OEPR Evaluator issues such Subsequent OEPR, be equal to one-twelfth (1/12th) of the product (rounded to the nearest cent) obtained by multiplying the Unit Price by the lesser of (w) the NEP OEPR Estimate obtained from such Subsequent OEPR or (x) the Most Recent Prior NEP Benchmark. The monthly Lump Sum Payment calculated as aforesaid shall remain in effect through the first to occur of (y) the end of the Term or (z) the end of the calendar month during which an OEPR Evaluator issues the next following Subsequent OEPR (if any) that is required or permitted under Section 1.F. (Subsequent OEPRs) of Attachment D (Calculation and Adjustment of Net Energy Potential) to this Contract. If any such next following Subsequent OEPR is issued, the monthly Lump Sum Payment shall, for the period commencing on the first Day of the calendar month following the calendar month during which an OEPR Evaluator issues such Subsequent OEPR, be re-calculated and adjusted as provided in this and shall continue in effect for the period provided in the preceding sentence.

D. Lump Sum Pro-Rata Adjustments.

1. Under the Company's previous forms of as-available power purchase agreements for renewable energy, the independent power producer was compensated for the production and delivery of electrical energy and assumed the risk of non-payment for events such as Force Majeure that prevented such production and delivery. Although under this Contract most of Subscriber Organization's compensation will be in the form of a Lump Sum Payment rather than for the production and delivery of electrical energy, it is not the intent of the Parties that Subscriber Organization should be entitled to unrestricted compensation in circumstances in which an independent power producer would not have been able to earn compensation under the Company's prior form of power purchase agreements (i.e., if the Facility or any portion thereof is unable to produce and deliver electric energy). Although the liquidated damages that are payable if the PV System Equivalent Availability Factor fails to satisfy the PV System Equivalent Availability Factor Performance Metric address this issue in certain of the circumstances when the PV System or a portion thereof is unable to generate electric energy, the PV System Equivalent Availability Factor does not account for events of Force Majeure because months containing such events are excluded from the PV System Equivalent Availability Factor calculation under Section 1.A.(Calculation of the PV System Equivalent Availability Factor) of Attachment C (Required Performance Metrics; Liquidated Damages) to

- this Contract. Similarly, in the case of the BESS, although the liquidated damages that are payable if the BESS Annual Equivalent Availability Factor fails to satisfy the BESS EAF Performance Metric addresses this issue in certain of the circumstances when the BESS or a portion thereof is unable to respond to Company Dispatch, the BESS Annual Equivalent Availability Factor does not account for events of Force Majeure because months containing such events are excluded from the calculation under Section 2 of Attachment H (BESS Annual Equivalent Availability) of this Contract.
2. Accordingly, and without limitation to the generality of the foregoing provisions of this Section 3. (Calculation of Lump Sum Payment), the monthly Lump Sum Payment shall be adjusted downward pro rata for each hour or portion thereof during the calendar month in question that the CBRE Facility or a portion thereof was not available to respond to Company Dispatch because of a Force Majeure condition (i) affecting the Facility or any portion thereof or (ii) that otherwise delays or prevents the Subscriber Organization from making the CBRE Facility or any portion thereof generate energy or be available for Company Dispatch.
 3. In the case of a BESS Force Majeure, such downward adjustment in the Lump Sum Payment shall be limited to the BESS Allocated Portion of the Lump Sum Payment. Further, during any periods in which there is a Force Majeure affecting both the PV System and the BESS, the Lump Sum Payment shall only be adjusted for the effect of the Force Majeure on the PV System.
 4. The hours the Facility is affected by a Force Majeure are converted to equivalent full outage hours by multiplying the actual duration of the event (hours) by (i) the size of the reduction in MWs or number of devices, divided by (ii) the Contract Capacity if the size of the reduction is in MWs or the total number of devices in the affected system if the size of the reduction is a device count. These equivalent hour(s) are then summed. The summation of equivalent full outage hours is then divided by the months total period hours (number of days in the month x 24hrs/day) to determine the pro-rated factor the Lump Sum Payment will be adjusted by.

EXAMPLE 1: : if the PV System has ten inverter(s) and, during the month of May (which has 31 calendar days or 744 period hours), one inverter is not available to respond to Company Dispatch for a period of 360 hours due to a Force Majeure condition as aforesaid, the monetary amount of the resulting downward adjustment to the monthly Lump Sum Payment for the month of May would be calculated as follows:

$$\text{Monetary Amount of Downward Adjustment} = \underline{\underline{\text{MLSP} \times 1/10}} \times \underline{\underline{360/744}}$$

where:

MLSP = The monthly Lump Sum Payment that would be payable for such month but for the downward adjustment.

EXAMPLE 2: if a Facility BESS System has forty inverters and, during the month of June (which has 720 period hours), one BESS module is not available to respond to Company Dispatch for a period of 240 hours due to a Force Majeure condition as aforesaid, the monetary amount of the resulting downward adjustment to the monthly Lump Sum Payment for the month of June would be calculated as follows:

$$\begin{array}{l} \text{Monetary Amount of} \\ \text{Downward Adjustment} \end{array} = \frac{\text{BLSP} \times 1/40}{240/720} \times$$

where:

BLSP = The BESS Allocated Portion of the Lump Sum Payment that would be payable for such month but for the downward adjustment.

Note: The foregoing monetary amount of downward adjustments shall be rounded to the nearest cent.

4. UPDATING MONTHLY SUBSCRIBER INFORMATION USED TO CALCULATE BILL CREDITS AND OTHER MATTERS.

A. No later than the last Day of each calendar month, the Subscriber Organization shall provide to the Company any and all changes to the Monthly Subscription Information to be used for such calendar month by entering new or updating previously-entered data through the CBRE Online Portal. Such data to be entered or changed by the Subscriber Organization shall include additions, deletions or changes to the listing of Subscribers, including any changes occurring by said last Day of such calendar month to the Subscriber's account number and service address attributable to each subscription and the Subscriber Allocation for each subscription.

B. For each calendar month, the purchase or transfer of all or any portion of a Subscriber's Allocation occurring on or before the 20th Day of such calendar month of which the Company is notified, as provided for in the preceding paragraph, shall have retroactive effect as of the first Day of such calendar month; the purchase or transfer of all or any portion of a Subscriber's Allocation occurring on or after the 21st Day of such calendar month, but prior to the first Day of the following calendar month, shall have effect as of the first Day of such following calendar month. The following shall be recalculated as of the last Day of each calendar month to account for the effectiveness of such purchases and transfers as aforesaid: (i) Unsubscribed RDG; (ii) the percentage of the Contract Capacity represented by the Subscriber Allocations for all Residential Subscribers; (iii) the number of individual Subscribers; and (iv) the percentage of Contract Capacity represented by all LMI Subscribers.

5. ADJUSTING PAYMENT TO SUBSCRIBER ORGANIZATION; LIQUIDATED DAMAGES.

A. The dollar amount to be paid to Subscriber Organization for the Unsubscribed RDG for a particular calendar month shall be as follows:

1. For the first six calendar months from and including the Commercial Operations Date, Company shall pay Subscriber Organization the Baseline SO Payment (i.e., the balance of the monthly Lump Sum Payment remaining after deducting the total dollar value of the Bill Credits for that month).

2. Beginning with the seventh calendar month following the Commercial Operations Date, the amount payable to Subscriber Organization for the Unsubscribed RDG for the month in question shall be equal to the Baseline SO Payment for such month (i.e., the balance of the monthly Lump Sum Payment remaining after deducting the total dollar value of the Bill Credits for such month) as adjusted downward to account for any of the following reductions that may be applicable for such month based on the recalculations made as of the end of such month pursuant to Section 5. of this Attachment B (Company Payments for Energy Dispatchability and Availability of BESS):

a. if the Unsubscribed RDG for such calendar month exceeds 15% of the Contract Capacity, the percentage by which the amount payable to Subscriber Organization is to be reduced shall be equal to the percentage point differential between 100% and the actual percentage of the Contract Capacity represented by Unsubscribed RDG. For example, if the actual Unsubscribed RDG is 18% of Contract Capacity for the month in question, the percentage point differential is 18% and the percentage by which the amount payable to Subscriber Organization is to be reduced is 18%;

b. if the total of the Subscriber Allocations for all Residential Subscribers for such calendar month is less than 40% of the Contract Capacity, the percentage by which the amount payable to Subscriber Organization is to be reduced shall be equal to one-fourth (0.25) of the percentage point differential between 40% and the actual percentage of the Contract Capacity represented by the Subscriber Allocations for all Residential Subscribers. For example, if the actual total of the Subscriber Allocations for all Residential Subscribers is 32% of Contract Capacity for the month in question, the

percentage point differential is 8% and the percentage by which the amount payable to Subscriber Organization is to be reduced is 2% (that is, one-fourth of the percentage point differential of 8%);

c. if the Subscriber Organization has committed to an Enhanced Residential Threshold in excess of 40% of Contract Capacity, and the total of Subscriber Allocations for all Residential Subscribers for such calendar month is less than the Enhanced Residential Threshold, the percentage by which the amount payable to Subscriber Organization is to be reduced shall be equal to one-tenth (0.1) of the percentage point differential between the Enhanced Residential Threshold and the higher of (i) 40% or (ii) the percentage of Contract Capacity represented by the total of Subscriber Allocations for all Residential Subscribers. For example, using the same 32% of Contract Capacity for the actual percentage of the Subscriber Allocations for all Residential Subscribers that was used in the example set forth in Section 5.A.2. b. immediately above, the determination of the percentage point differential would be based on 40% because that is higher than 32%. Assuming that Subscriber Organization had committed to an Enhanced Residential Threshold of 50% of Contract Capacity, 10% is the percentage point differential between 40% and the Enhanced Residential Threshold, and the percentage by which the Baseline SO Payment is to be reduced is 1% (that is, one-tenth of the percentage point differential of 10%). For the example under discussion (that is, the percentage of Contract Capacity represented by the Subscriber Allocations for all Residential Subscribers is 32%), the aforementioned 1% reduction in the amount payable to Subscriber Organization would be in addition to the 2% reduction under Section 5.A.2.b.;

d. if the Facility has less than 4 individual Subscribers for such calendar month, the percentage by which the amount payable to Subscriber Organization is to be reduced shall be equal to the percentage by which the Facility fell below the threshold of having 4 individual Subscribers. For example, if the actual number of individual Subscribers is 3 for the month in question, the shortfall in individual Subscribers is 1, which is 25% of 4. Thus, the amount payable to Subscriber Organization shall be reduced by 25%; and

e. If the Subscriber Organization's Facility CBRE Program has a LMI Minimum Threshold, adjustment to the amount to Subscriber Organization is to be reduced shall be as set forth in Part III. Section E. (Payment Reductions and Liquidated Damages) of the CBRE Tariff. The applicable percentage to be used to calculate such reduction, as determined pursuant to said Part III, Section E. of the CBRE Tariff, is referred to below as the "Applicable LMI Percentage Reduction."

3. Beginning with the seventh calendar month following the Commercial Operations Date, the amount payable to Subscriber Organization for Unsubscribed RDG for such month shall be equal to the Baseline SO Payment for such month (i.e., the balance of the monthly Lump Sum Payment remaining after deducting the total dollar value of the Bill Credits for such month) as adjusted downward by a percentage equal to the sum for such calendar month obtained by adding up the percentage points as calculated for such month pursuant to Section 5.A.2. immediately above. For example, using the five different percentage points used as examples in said Section 5.A.2., the amount payable to Subscriber Organization for such month would be reduced by the sum of $18\%+2\%+1\%+25\%+\text{Applicable LMI Percentage Reduction}$.

B. Beginning with the seventh calendar month following the Commercial Operations Date, if there is no Unsubscribed RDG but the summing of the percentage points for such month pursuant to Section 5.A.3., above, results in a percentage that is more than zero, Subscriber Organization shall promptly pay upon demand, and Company shall accept, liquidated damages for failure to achieve the requisite thresholds for such month in an amount equal to the aforementioned percentage multiplied by the Lump Sum Payment for such month. For example, using the percentage points used in the examples set forth in Section 5.A.2. Of this Attachment B (Company Payments for Energy, Dispatchability and Availability of BESS), the 18% figure would no longer be applicable because in this scenario there is no Unsubscribed RDG. Thus, the percentage used to calculate the liquidated damages payable under this Section 5.B. would be the sum of $2\%+1\%+25\%+\text{Applicable LMI Percentage Reduction}$. Company shall have the option of drawing such liquidated damages from the Operating Period Security.

6. **TEST ENERGY.** Company shall use reasonable efforts to accept test energy that is delivered as part of the normal testing for generators (such as energy delivered to Company during the Control System Acceptance Test but not during the Acceptance Test), provided Subscriber Organization shall use reasonable efforts to coordinate such normal testing with Company so as to minimize adverse impacts on the Company System and operations. Company shall not compensate Subscribers or Subscriber Organization for test energy.

7. **TAX CREDIT PASS THROUGH.** Company acknowledges and agrees that the Federal Refundable Tax Credit and Federal Non-Refundable Tax Credit shall inure to the benefit of the Claiming Entity; provided, however, that Subscriber Organization acknowledges and expressly agrees that the Federal Refundable Tax Credit and Federal Non-Refundable Tax Credit, with regard to Subscriber Organization's Facility, have been calculated into the Contract Pricing based on the maximization of such credits. In the event that Subscriber Organization's Facility does not gain the benefit of the Federal Refundable Tax Credit and/or the Federal Non-Refundable Tax Credit, Subscriber Organization expressly acknowledges and agrees that it shall not seek to amend the Contract Pricing.

A. Because the Hawai'i tax treatment that will apply to renewable energy technologies on the Commercial Operations Date is uncertain, the parties acknowledge that the Contract Pricing was set assuming Subscriber Organization will not be eligible for any Hawai'i Renewable Energy Tax Credit. The intent of this Section 7. (Tax Credit Pass Through) is to entitle Company, for the benefit of its customers, to a payment equal to 100% of the maximum Hawai'i Renewable Energy Tax Credit for which Subscriber Organization is eligible with respect to the Facility and receives during the Term, as more fully set forth in this Section 7. (Tax Credit Pass Through).

B. If, as of the Commercial Operations Date, or, if not available at the Commercial Operations Date, at any subsequent time during the Term, a Hawai'i Refundable Tax Credit is reasonably available to Subscriber Organization or its Affiliates with respect to the Facility, the following shall apply:

1. Subscriber Organization or Subscriber Organization's Affiliate will apply for such Hawai'i Refundable Tax Credit, it being understood and agreed that if Subscriber Organization applies for a Hawai'i Refundable Tax Credit as of the Commercial Operations Date, it shall have fulfilled its obligations hereunder to apply for the Hawai'i Refundable Tax Credit;
2. Subscriber Organization shall make a payment to Company in an amount equal to one hundred percent (100%) of the Net Amount of such Hawai'i Refundable Tax Credit within thirty (30) Days after funds are received from the Hawai'i Department of Taxation;
3. Upon application for the Hawai'i Refundable Tax Credit, an officer of Subscriber Organization will deliver to Company a notice (A) describing Subscriber Organization's efforts to apply for and obtain the Hawai'i Refundable Tax Credit, (B) confirming that Subscriber Organization has applied for the Hawai'i Refundable Tax Credit, and (C) certifying that Subscriber Organization has used commercially reasonable efforts to apply for and obtain the maximum reasonably available Hawai'i Refundable Tax Credit as provided in this Section 7. (Tax Credit Pass Through);
4. Upon receipt of any funds from the Hawai'i Department of Taxation for the Hawai'i Refundable Tax Credit, an officer of Subscriber Organization or an Affiliate of Subscriber Organization, if applicable, will deliver a notice to Company certifying (A) the amount of funds received, (B) and the amount of payment that will be made to Company, net of any documented and reasonable financial, legal, administrative, and other costs required to claim and transfer such funds to Subscriber Organization, as supported by the officer's certificate as to the amount of such costs and the reasonableness thereof.

C. If, as of the Commercial Operations Date, a Hawai'i Refundable Tax Credit is unavailable, but a Hawai'i Non-Refundable Tax Credit is available to Subscriber Organization or its Affiliates with respect to the Facility, or at any subsequent time during the Term, a Hawai'i Non-Refundable Tax Credit becomes available to Subscriber Organization or its Affiliates with respect to the Facility, notwithstanding that Subscriber

Organization may have applied for a Hawai'i Refundable Tax Credit, and in either case Subscriber Organization can claim, or enable its investors to claim, such Hawai'i Non-Refundable Tax Credit, the following shall apply:

1. Subscriber Organization or an Affiliate of Subscriber Organization will apply for any available Hawai'i Non-Refundable Tax Credit, it being understood and agreed that if Subscriber Organization applies for a Hawai'i Non-Refundable Tax Credit as of the Commercial Operations Date, it shall have fulfilled its obligations hereunder to apply for the Hawai'i Non-Refundable Tax Credit;
2. Subscriber Organization shall make a payment to Company in an amount equal to one hundred percent (100%) of the Net Amount of such Hawai'i Non-Refundable Tax Credit that Subscriber Organization can claim in the tax year in question within sixty (60) Days after the filing date of the applicable tax return for the tax year in which such Hawai'i Non-Refundable Tax Credit is utilized;
3. Upon the filing of the applicable tax return(s), an officer of Subscriber Organization or an Affiliate of Subscriber Organization, if applicable, will deliver a notice to Company (A) describing Subscriber Organization's efforts to apply for and obtain the Hawai'i Non-Refundable Tax Credit, (B) confirming that Subscriber Organization has applied for the Hawai'i Non-Refundable Tax Credit, and (C) certifying that Subscriber Organization has used commercially reasonable efforts to apply for and obtain the maximum reasonably available Hawai'i Non-Refundable Tax Credit as provided in this Section 7. (Tax Credit Pass Through);
4. Upon receipt of any funds for the Hawai'i Non-Refundable Tax Credit, an officer of Subscriber Organization or an Affiliate of Subscriber Organization, if applicable, will deliver a notice to Company certifying (A) the amount of funds received, (B) and the amount of payment that will be made to Company, net of any documented and reasonable financial, legal, administrative, and other costs required to claim, monetize and transfer such funds to Subscriber Organization, as supported by the officer's certificate as to the amount of such costs and the reasonableness thereof.

D. Subscriber Organization shall use commercially reasonable efforts to apply for and obtain the maximum reasonably available Hawai'i Refundable and/or Non-Refundable Tax Credit as provided in this Section 7 (Tax Credit Pass Through). If Subscriber Organization fails to apply for and to use commercially reasonable efforts to obtain such Hawai'i Renewable Energy Tax Credit as described above, then Company shall be entitled to liquidated damages in an amount equal **[\$150,000 per MW of Contract Capacity]**. Subscriber Organization and Company agree and acknowledge that (i) the failure to use commercially reasonable efforts as provided in the preceding sentence would result in damages to Company in the form of reduction or loss of a benefit for Company's customers that would be difficult or impossible to calculate with certainty and (ii) **[Note - Insert Amount That Equals \$150,000 Per Mw Of Contract Capacity]** is an appropriate approximation of such damages. Company's right to collect liquidated damages as described in this Section 7.D. shall constitute Company's exclusive remedy and fulfillment of all Subscriber Organization's liability with respect to its obligations to maximize the amount of Hawai'i Renewable Energy Tax Credit. Such liquidated damages shall be provided to Company in the form of a lump sum payment by Subscriber Organization or as a credit against any amounts due by Company to Subscriber Organization under this Contract, as Company reasonably determines.

E. If, prior to the application in Section 7.B. or filing in Section 7.C. of this Attachment B (Company Payments for Energy, Dispatchability and Availability of BESS), as applicable, a change in tax law occurs to introduce a Hawai'i Production Tax Credit or an alternative renewable tax credit, Subscriber Organization will use commercially reasonable efforts to determine which tax strategy is likely to result in the larger Net Amount (based on net present value for tax credits earned over time) of claimable tax credits. If, based on such efforts, Subscriber Organization determines that either Section 7.B. or Section 7.C. would result in a larger Net Amount of usable tax credits, an officer of Subscriber Organization will deliver a notice to Company certifying that Subscriber Organization has reasonably determined that the selected form of Hawai'i Renewable Energy Tax Credit is likely to result in the larger Net Amount (based on net present value for tax credits earned over time)

of claimable tax credits and explaining the rationale for such determination. If, however, Subscriber Organization reasonably determines that such Hawai'i Production Tax Credit is likely to result in the larger Net Amount (based on net present value for tax credits earned over time) of claimable tax credits and that it reasonably can obtain such Hawai'i Production Tax Credit, Subscriber Organization shall promptly notify Company in writing and explain the rationale for such determination, and Subscriber Organization and Company shall negotiate in good faith and use commercially reasonable efforts to agree upon lump sum payments and/or credits or adjustments to the Contract Pricing and other terms of this Contract as may be required to best benefit Company's customers with 100% of the Net Amount of such tax benefits and preserve the intended economic benefits to the Parties arising from this Contract.

F. Company reserves the right to have Subscriber Organization's application for the Hawai'i Renewable Energy Tax Credit in Section 7.B. or Section 7.C., or the Hawai'i Production Tax Credit or alternative tax credit under Section 7.E. of this Attachment B (Company Payments for Energy, Dispatchability and Availability of BESS) reviewed by an Independent Tax Expert to determine if such application is expected to maximize available tax credits to best benefit Company's customers, in which case, the provisions of this Section 7.F. shall apply. Company shall deliver to Subscriber Organization a written notice (the "Nomination Notice") of: (i) the names of three persons qualified and willing to accept appointment as an Independent Tax Expert; (ii) a description provided by each nominee of his or her qualifications to serve as an Independent Tax Expert; (iii) a written undertaking by each nominee to review Subscriber Organization's tax credit strategy and application, and (iv) each nominee's fee proposal. Subscriber Organization and Company shall agree on a mutually acceptable person to serve as the Independent Tax Expert within ten (10) Business Days of Subscriber Organization's receipt of Company's written notice. If the Parties fail to agree upon a mutually acceptable Independent Tax Expert within the aforesaid ten Business Day period, such disagreement shall be resolved pursuant to Section 7.G. of this Attachment B (Company Payments for Energy, Dispatchability and Availability of BESS). Company shall pay the fees and expenses of the Independent Tax Expert and Subscriber Organization shall promptly reimburse Company for one-half of such fees and expenses.

G. Any dispute arising under this Section 7. (Tax Credit Pass Through) of this Attachment B (Company Payments for Energy, Dispatchability and Availability of BESS) shall constitute a "Dispute" within the meaning of Section 17. (Dispute Resolution) of the Contract and shall be resolved as provided in said Section 17. (Dispute Resolution).

H. For purposes of this Section 7. (Tax Credit Pass Through) of this Attachment B (Company Payments for Energy, Dispatchability and Availability of BESS), an Affiliate of Subscriber Organization is a company that directly or indirectly controls, is controlled by, or is under common control with Subscriber Organization, and Subscriber Organization may perform its obligations under this Attachment B (Company Payments for Energy, Dispatchability and Availability of BESS) directly or through one or more Affiliates.

--END--

ATTACHMENT C

REQUIRED PERFORMANCE METRICS; LIQUIDATED DAMAGES

1. PV SYSTEM EQUIVALENT AVAILABILITY FACTOR; LIQUIDATED DAMAGES; TERMINATION RIGHTS.

- A. Calculation of the PV System Equivalent Availability Factor. Following the end of each LD Period, the PV System Equivalent Availability Factor shall be calculated for such LD Period as follows:

$$\text{PV System Equivalent Availability Factor} = 100\% \times \frac{AH-EDH}{PH}$$

where:

Period Hours (PH) is the total number of hours in the LD Period counting twenty-four (24) hours per day. In a normal year, PH = 8,760, and in a leap year PH = 8,784.

Available Hours (AH) is the number of hours that the PV System is not on Outage. It is the sum of all Service Hours (SH) + Reserve Shutdown Hours (RSH).

An "Outage" exists whenever the entire PV System is not online producing electric energy and is not in a Reserve Shutdown state.

Service Hours (SH) is the number of hours during the LD Period the PV System is online and producing electric energy to meet Company Dispatch and/or to maintain the BESS State of Charge.

Reserve Shutdown Hours (RSH) is the number of hours the PV System was available to the Company System but not providing electric energy or is offline at the Company's request for reasons other than Subscriber Organization-Attributable Non-Generation, or is offline due to insufficient irradiance levels based on the inverter manufacturer's minimum irradiance level for production. All hours between 7:00 pm and 6:00 am will be considered RSH. The PV System will be considered RSH in these hours, even if the system would otherwise be in an outage or derated state.

A "PV System Derating" exists if the Facility is available for Company Dispatch, but at less than full potential output for the given irradiance conditions, including deratings due to Subscriber Organization-Attributable Non-Generation or deratings by Company pursuant to Section 5.C (Company Rights of Dispatch).

For avoidance of doubt, if there is a PV System Outage occurring, there cannot also be a PV System Derating.

Equivalent Derated Hours (EDH) is the sum of ESADH, EPDH, and EUDH. For deratings due to PV System inverter unavailability, the equivalent full outage hour(s) are calculated by multiplying the actual duration of the derating (hours) by the number of inverters in the PV System unavailable and dividing by the total number of inverters in the PV System. For deratings that do not impact the availability of an entire inverter or set of entire inverters, the equivalent full outage hour(s) are calculated by multiplying the actual duration of the derating (hours) by the size of the derating (in MW) divided by the Contract Capacity.

Equivalent Subscriber Organization-Attributable Derated Hours (ESADH): A Subscriber Organization-Attributable Derating occurs when a derating exists due to Subscriber Organization-Attributable Non-Generation or deratings by Company pursuant to Section 5.3 (Company Rights of Dispatch) of the Contract. Each individual derating is transformed into equivalent full outage hour(s). These equivalent hour(s) are then summed.

Equivalent Planned Derated Hours (EPDH) includes Planned Deratings (PD) and Maintenance Deratings (D4). A Planned Derating is when the PV System experiences a derating scheduled well in advance and for a predetermined duration. A Maintenance Derating is a derating that can be deferred beyond the end of the next weekend (Sunday at midnight or before Sunday turns into Monday) but requires a reduction in capacity before the next Planned Derating (PD). Each individual Deration is transformed into equivalent full outage hour(s). These equivalent hour(s) are then summed.

Equivalent Unplanned Derated Hours (EUDH): An Unplanned Derating (Forced Derating) occurs when the PV System experiences a derating that requires a reduction in availability before the end of the nearest following weekend. Unplanned Derations include those due to Subscriber Organization-Attributable Non-Generation. Each individual Unplanned Derating is transformed into equivalent full outage hour(s). These equivalent hour(s) are then summed.

The effect of Force Majeure is taken into account in calculating the PV System Equivalent Availability Factor over the 12 calendar month LD Period as follows: When an LD Period contains any hours in a month during which the PV System or a portion of the PV System is unavailable due to Force Majeure, then such month shall be excluded from the LD Period and the LD Period shall be extended back in time to include the next previous month during which there was no such unavailability of the PV System or a portion thereof due to Force Majeure. This means the PV System Equivalent Availability Factor would not change from that determined in the month directly preceding a month containing Forced Majeure.

EXAMPLE: The following is an example of a PV System Equivalent Availability Factor calculation and is included for illustrative purposes only. Assume the following:

- PV System has 10 inverters and the Facility has a Contract Capacity of 30 MWs.
- LD Period = first 12 calendar months of the Contract (non-leap year).
- PV System was online and producing electric energy for 4,000 hours and was available but not producing electric energy due to lack of sufficient irradiance for production (i.e., not Subscriber Organization-Attributable Non-Generation) for 500 hours.
- 3 Inverters were offline for 100 hours due to a Planned Derating while not otherwise in RSH.
- 2 Inverters were offline for 50 hours due to an Unplanned Derating while not in RSH.
- The PV System had a 3 MW derating for 100 hours due to Subscriber Organization-Attributable Non-Generation while not otherwise in RSH.
- The PV System Equivalent Availability Factor would be calculated as follows:

$$PH = 8,760 \text{ hours in 12 calendar months} = 8,760 \text{ hours}$$

$$SH = 4,000 \text{ hours}$$

$$RSH = 500 \text{ hours} + (11 \text{ hours/day} \times 365 \text{ days}) = 4,515 \text{ hours}$$

$$AH = SH + RSH = 4,000 \text{ hours} + 4,515 \text{ hours} = 8,515 \text{ hours}$$

$$ESADH = 100 \text{ hours} \times \left(\frac{3 \text{ MW}}{30 \text{ MW}}\right) = 10 \text{ hours}$$

$$EPDH = 100 \text{ hours} \times \left(\frac{3 \text{ inverters}}{10 \text{ inverters}}\right) = 30 \text{ hours}$$

$$EUDH = 50 \text{ hours} \times \left(\frac{2 \text{ inverters}}{10 \text{ inverters}}\right) = 10 \text{ hours}$$

$$EDH = ESADH + EPDH + EUDH = 10 \text{ hours} + 30 \text{ hours} + 10 \text{ hours} = 50 \text{ hours}$$

$$EAF = 100\% \times \frac{8,515 - 50}{8,760} = 96.6\%$$

- B. PV System Equivalent Availability Factor Performance Metric and Liquidated Damages. For each LD Period, a PV System Equivalent Availability Factor shall be calculated as provided in accordance with Section 1. A. (Calculation of PV System Equivalent Availability Factor) of this Contract. In the event the PV System Equivalent Availability Factor is less than 98% (the "PV System Equivalent Availability Factor Performance Metric") for any LD Period, Subscriber Organization shall be subject to liquidated damages as set forth in this Section 1. B. (PV System Equivalent Availability Factor Performance Metric and Liquidated Damages). For avoidance of doubt, because the PV System Equivalent Availability Factor is calculated over an LD Period of 12 calendar months, the first month for which liquidated damages would be calculated under this Section 1.B. (PV System Equivalent Availability Factor Performance Metric and Liquidated Damages) would be the last calendar month of the initial Contract Year. If the PV System Equivalent Availability Factor for a LD Period is less than the PV System Equivalent Availability Factor Performance Metric, Subscriber Organization shall pay, in accordance with Attachment C, Section 8 (Payment of Liquidated Damages for Failure to Achieve Performance Metrics; Limitation on Liquidated Damages), and Company shall accept, as liquidated damages for Subscriber Organization's failure to achieve the PV System Equivalent Availability Factor Performance Metric for such LD Period, an amount calculated in accordance with the following formula:

<u>PV System Equivalent Availability Factor</u>	<u>Amount of Liquidated Damages Per Calendar Month</u>
---	--

97.9% and below

For each one-tenth of one percent (0.001) by which the PV System Equivalent Availability Factor for such LD Period falls below the PV System Equivalent Availability Factor Performance Metric, an amount equal to 0.001917 of the Applicable Period Lump Sum Payment for the last calendar month of such LD Period.

For purposes of determining liquidated damages under the preceding formula, the amount by which the PV System Equivalent Availability Factor for the LD Period in question falls below the applicable threshold shall be rounded to the nearest one-tenth of one percent (0.001). Each Party agrees and acknowledges that (i) the

damages that Company would incur if the Subscriber Organization fails to achieve the PV System Equivalent Availability Factor Performance Metric for a LD Period would be difficult or impossible to calculate with certainty and (ii) the aforesaid liquidated damages are an appropriate approximation of such damages.

EXAMPLE: The following is an example calculation of liquidated damages for the PV System Equivalent Availability Factor Performance Metric and is included for illustrative purposes only. Assume the monthly Lump Sum Payment is \$1,000,000 and the PV System Equivalent Availability Factor is 96.9% as calculated in the example in Section 2.5(a) (Calculation of the PV System Equivalent Availability Factor) above.

The liquidated damages would be calculated as follows:

Applicable Period Lump Sum Payment = \$1,000,000

$\$1,000,000 \times .001917 = \$1,917$

$98.0\% - 96.9\% = 1.1\%$

$1.1\%/0.1\% = 11$

$\$1,917 \times 11 = \$21,087$

- C. PV System Equivalent Availability Factor Termination Rights. The Parties acknowledge that, although the intent of the liquidated damages payable under Section 1.B. (PV System Equivalent Availability Factor Performance Metric and Liquidated Damages) is to compensate Company for the damages that Company would incur if the Subscriber Organization fails to achieve the PV System Equivalent Availability Factor Performance Metric for a LD Period, such liquidated damages are not intended to compensate Company for the damages that Company would incur if a pattern of underperformance establishes a reasonable expectation that the PV System is likely to continue to substantially underperform the PV System Equivalent Availability Factor Performance Metric. Accordingly, and without limitation to Company's rights under said Section 1.B. (PV System Equivalent Availability Factor Performance Metric and Liquidated Damages) for those LD Periods during which the Subscriber Organization failed to achieve the PV System Equivalent Availability Factor Performance Metric, the failure of the Facility to achieve a PV System Equivalent Availability Factor of not less than **84%** for each of three consecutive Contract Years shall constitute an Event of Default under this Contract for which Company shall have the rights (including but not limited to the termination rights) set forth in Section 13. (Events of Default by Subscriber Organization) and Section 15. (Damages in the Event of Termination by Company).

2. MEASURED PERFORMANCE RATIO; LIQUIDATED DAMAGES; TERMINATION RIGHTS.

A. Calculation of Measured Performance Ratio.

1. The Measured Performance Ratio ("MPR") represents the PV System's measured AC power output compared to its theoretical DC power output as adjusted for the plane of array irradiance and weather conditions measured at the Site [**DRAFTING NOTE: MAY REQUIRE REVISION FOR DC OUTPUT**]. The gross PV System output in MW and MVAR will be measured at such point mutually agreed to by the Parties on the Facility's single-line diagram attached hereto as Attachment F, Exhibit F-5 (Single-Line Drawing and Interface Block Diagram) to this Contract.
- Following the end of each MPR Assessment Period, the MPR shall be calculated for such MPR Assessment Period (using the previous 12 months of data) as follows:

$$MPR_{corr} = \frac{\sum_i P_{AC,i}}{\sum_i \left[P_{DC,STC} \left(\frac{G_{POA,i}}{G_{STC}} \right) \left(1 - \frac{\delta}{100} (T_{cell,type_avg} - T_{cell,i}) \right) \right]}$$

Where:

i = each 15-minute interval during the MPR Assessment Period where the conditions set forth in 2.A.1. are met.

$P_{AC,i}$ is the measured AC power output of the PV System measured at the Point of Interconnection and BESS inverters' AC input averaged over time period i in MW.

G_{STC} = plane of array irradiance at the standard condition of $1,000 \text{ W/m}^2$.

$P_{DC,STC}$ is the DC rated capacity of the PV System at the standard test conditions of $1,000 \text{ W/m}^2$ and 25°C (MW), (i.e., the DC power rating of the PV panels at standard test conditions multiplied by the number of PV panels in the Facility).

$G_{POA,i}$ is the measured plane of array irradiance averaged over time period i (W/m^2).

$T_{cell,i}$ = cell temperature computed from measured meteorological data averaged over time period i using the equation provided below. ($^\circ\text{C}$)

$T_{cell,type_avg}$ = annual average irradiance-weighted cell temperature computed from one year of weather data using the GPR performance metric weather file and the equation below. ($^\circ\text{C}$) Calculated once per GPR.

δ = temperature coefficient for power ($\%/\text{C}$, negative in sign) that corresponds to the installed photovoltaic modules.

$$T_{cell,type_avg} = \frac{\sum_j [G_{POA,type_j} \times T_{cell,type_j}]}{\sum_j G_{POA,type_j}}$$

Where:

j = each hour of the year in the GPR performance metric weather file (hours 1-8760).

$G_{POA,type_j}$ = Plane of array irradiance for each hour of the year determined from the GPR performance metric weather file and tracker orientation. This irradiance is zero (0) when the sun is not up. (W/m^2).

$T_{cell,type_j}$ = calculated cell operating temperature for each hour of the year computed using the GPR performance metric weather file for the weather variables in the equation for $T_{cell,i}$ below.

$$T_{cell,i} = G_{POA,i} \times e^{(a+b \times WS_i)} + T_{a,i} + \left(\frac{G_{POA,i}}{G_{STC}} \times dT_{cond} \right)$$

Where:

$T_{a,i}$ = the measured ambient temperature averaged over time period i [$^\circ\text{C}$]

WS_i = the measured wind speed corrected to a measurement height of 10 meters (using the anemometer height and proper Hellmann coefficient) averaged over time period i [m/s]

a = empirical constant reflecting the increase of module temperature with sunlight as presented in Table 2 below.

b = empirical constant reflecting the effect of wind speed on the module temperature as presented in Table 2 below [s/m]

e = Euler's constant and the base for the natural logarithm.

dT_{cond} = conduction temperature coefficient from module to cell as presented in Table 2 below.

Table 2. Empirical Convective Heat Transfer Coefficients Module Type	Mount	a	b	dT_{cond}
Glass/cell/glass	Open rack	- 3.47	- 0.0594	3
Glass/cell/glass	Close-roof mount	- 2.98	- 0.0471	1
Glass/cell/polymer sheet	Open rack	- 3.56	- 0.0750	3
Glass/cell/polymer sheet	Insulated back	- 2.81	- 0.0455	0
Polymer/thin-film/steel	Open rack	- 3.58	- 0.1130	3

- The time periods used in the foregoing calculation shall be only periods during which, for the entire 15-minute interval, the PV System output is allowed to convert all irradiance to gross AC power and is not offline due to insufficient irradiance levels based on the inverter minimum requirements for production. Data points that will be excluded are limited to data points where: (A) the GPOA is below minimum threshold, (B) GPOA above the maximum threshold (C) the PV System is in RSH, (D) when there is a EUDH or EPDH, (E) the PV System was not allowed to convert the full DC output to AC energy; or (F) when there is any other Outage. The aforementioned 15-minute intervals are fixed intervals that commence, in sequence, at the top of each hour and at 15, 30 and 45 minutes past the hour. At the end of each month, Subscriber Organization shall provide Company a report that lists all hours when such excluded data points occur (from the Facility's SCADA system as necessary) to validate the exclusion of any data points from the calculation set forth in Section 2.A., above. This information shall be validated on a monthly basis.

B. MPR Test. In the event that the set of operational data points under Section 2.A. that is available for any month to calculate the MPR cannot be validated to Company's reasonable satisfaction or in the event there were not at least 16 such data points during such month that could be used to calculate the MPR, the Company shall have the right to perform a test ("MPR Test") to collect the data points for such month to be used to calculate the MPR in lieu of the use of operational data for such month. The Company shall retain sole discretion as to when to conduct the MPR Test and the MPR Test may be conducted at any point during the month following the month for which Company was either unable to validate the set of operational data points for such month or there were not at least 16 data points available during such month, provided that Company will provide Subscriber Organization three (3) Business Days' notice prior to conducting the MPR Test. The MPR Test shall have a minimum duration of four (4) hours and shall run until at least 16 data points are collected that meet the criteria set forth in Section 2.A., subject to the limitation set forth in the last sentence of this Se). To the extent possible, the Company shall schedule the MPR Test for a period where all inverters in the PV System and BESS are fully available and weather conditions are expected to be optimum allowing the PV System to generate at full capacity for the duration of the MPR Test (if possible). However, if Company chooses a period where some of the Facility inverter(s)

are unavailable, P_{DCSTC} shall be adjusted to account for any reduction in capability to accept energy from the PV System due to the unavailable inverter(s).

- For each MPR Assessment Period that includes one or more months for which a MPR Test was performed, the data points collected during said MPR Test for such month(s) shall be used together with the data points for months for which an MPR Test was not conducted to calculate the MPR for the MPR Assessment Period in question using the formula set forth in Section 2. A. 1., above. The result of the calculation based on the MPR Test shall be the MPR for the MPR Assessment Period in question.

EXAMPLE: The following is an example of a Measured Performance Ratio calculation and is included for illustrative purposes only. Assume the following:

- Facility with 120,000 panels with a standard test condition rating of 300 W
- $P_{DCSTC} = 120,000 \times 300 \text{ W} = 36 \text{ MW}$
- For illustrative purposes only, 4 hours of data which met the criteria specified in 2.6(a) (iii) have been recorded over the MPR Assessment Period. It should be noted that all available operational data that meets the criteria specified in Section 2.A.1. shall be included in the actual calculation.

Time Period	Average Measured Plane of Array Irradiance (W/m^2)	Average Measured Net AC Power at POI and BESS Inverters (MW)	Average Measured Ambient Temperature ($^{\circ}\text{C}$)	10 Meter Elevation Average Measured Wind Speed (m/s)
1	690	16	27	3
2	850	11	26	8
...
i	750	19	29	7

$$MPR_{corr} = \frac{\sum_i P_{AC,i}}{\sum_i \left[P_{DCSTC} \left(\frac{G_{POA_i}}{G_{STC}} \right) \left(1 - \frac{\delta}{100} (T_{cell_typ_avg} - T_{cell,i}) \right) \right]}$$

where:

$$T_{cell,i} = G_{POA_i} \times e^{(a+b \times WS_i)} + T_{a,i} + \left(\frac{G_{POA_i}}{G_{STC}} \times dT_{cond} \right)$$

Assuming:

The temperature coefficient (δ) of the installed modules is $-0.4\%/^{\circ}\text{C}$

The average irradiance-weighted cell temperature ($T_{cell_typ_avg}$) has been calculated as 28°C

The installed modules are a glass/cell/polymer sheet module type using an open rack mount.

($a = -3.56$; $b = -0.0750$; $dT_{cond} = 3$)

$$\sum_i P_{AC,i} = 16 \text{ MW} + 11 \text{ MW} + \dots + 19 \text{ MW} = \mathbf{305 \text{ MW}}$$

$$\begin{aligned} \sum_i \left[P_{DCSTC} \left(\frac{G_{POA_i}}{G_{STC}} \right) \left(1 - \frac{\delta}{100} (T_{cell_type_avg} - T_{cell,i}) \right) \right] &= 36 \text{ MW} \times [(690/1000) \times (1 - \\ &(0.4/100) \times (28 - ((690 \times e^{(-3.56 - 0.075 \times 3)} + 27) + ((690/1000) \times 3))) + \\ &(850/1000) \times (1 - (0.4/100) \times (28 - ((850 \times e^{(-3.56 - 0.075 \times 8)} + 26) + ((850/1000) \times 3))) + \\ &\dots + \\ &(750/1000) \times (1 - (0.4/100) \times (28 - ((750 \times e^{(-3.56 - 0.075 \times 7)} + 29) + ((750/1000) \times 3))) \end{aligned}$$

= 374.76 MW

MPR = 305 MW/ 374.76 MW = 0.814

C. Determination of GPR Performance Metric.

1. Upon Commencement of Commercial Operations. If a copy of the IE Energy Assessment Report together with the supporting Year 1 P-Value of 50 8760 data (plane of array irradiance, Year 1 P-Value of 50 8760 and corresponding power output) is not provided to Company in accordance with Section 1.C. (NEP IE Estimate and Company-Designated NEP Estimate) of Attachment D (Calculation and Adjustment of Net Energy Potential), the GPR Performance Metric for the period commencing on the Commercial Operations Date through the end of the calendar month during which the Initial OEPR is issued shall be 0.85. If a copy of the IE Energy Assessment Report together with the supporting data (plane of array irradiance, ambient temperature, windspeed and corresponding power output) is provided to Company in accordance with Section 1.C. (NEP IE Estimate and Company-Designated NEP Estimate) of Attachment D (Calculation and Adjustment of Net Energy Potential), the GPR Performance Metric shall be the GPR set forth in the IE Energy Assessment Report, provided that such GPR is justified by such supporting data and consistent with the and based on the Year 1 P-Value of 50 8760 data, minimum irradiance level and points of power measurement specified in Section 2.A. of this Attachment C. In the event that the IE Assessment Report includes the supporting data (plane of array irradiance, ambient temperature, windspeed and corresponding power output) relied upon in arriving at the NEP IE Estimate, but does not set forth a GPR, the GPR Performance Metric shall be calculated using such supporting data and the Measured Performance Ratio formula in Section 2.A. of this Attachment C. Within 30 Days of Company's receipt of the IE Energy Assessment Report together with the aforementioned supporting data, Company shall provide written notice to Subscriber Organization of either (aa) the GPR Performance Metric derived from such supporting data or (bb) Company's inability to reasonably derive a GPR Performance Metric from such supporting data, in which case the GPR Performance Metric shall be 0.85.

Commencing With Initial OEPR. For the period commencing with the first Day of the calendar month following the establishment of the NEP OEPR Estimate for the Initial OEPR (as provided in Section 1.E (Initial OEPR) and Sections 2.G. (Review of the First OEPR Evaluator Report) and 2.H. (Review of the Second OEPR Evaluator Report) of Attachment D (Calculation and Adjustment of Net Energy Potential) to this Contract through the end of the calendar month during which the NEP OEPR Estimate for the first Subsequent OEPR is established as provided in Section (Subsequent OEPRs) and Sections 2.G. (Review of the First OEPR Evaluator Report) and 2.H. (Review of the Second OEPR Evaluator Report) of Attachment D (Calculation and Adjustment of Net Energy Potential) to this Contract, the GPR Performance Metric shall be the GPR as established through the Initial OEPR process as aforementioned. If no GPR has been established through the Initial OEPR process, the GPR Performance Metric shall be 0.85.

Commencing With the First Subsequent OEPR and Thereafter. Commencing with the establishment of the NEP OEPR Estimate for the first Subsequent OEPR as provided in Section F.1. (Subsequent OEPRs) and Sections 2.G. (Review of the First OEPR Evaluator Report) and 2.H. (Review of the Second OEPR Evaluator Report) of Attachment D (Calculation and Adjustment of Net Energy Potential) to this Contract, for each period commencing with the first Day of the calendar month following the establishment of the NEP OEPR Estimate for a Subsequent OEPR (including but not limited to the first Subsequent OEPR) through the end of the calendar month during which the NEP OEPR Estimate is established for the next Subsequent OEPR, the GPR Performance Metric shall be the GPR established for the applicable Subsequent OEPR. If no GPR has been established through the then applicable Subsequent OEPR process, the GPR Performance Metric shall be 0.85.

D. GPR Performance Metric and Liquidated Damages. For each MPR Assessment Period, a Measured Performance Ratio shall be calculated as provided in Attachment C Section 2.A. (Calculation of Measured Performance Ratio) to this Contract. In the event the MPR is less than 95% of the GPR Performance Metric as adjusted by the degradation factor set forth below, Subscriber Organization shall pay, in accordance with Attachment C Section 8. (Payment of Liquidated Damages for Failure to Achieve Performance Metrics; Limitation on Liquidated Damages), and Company shall accept, as liquidated damages for Subscriber Organization's failure to achieve the GPR Performance Metric for such MPR Assessment Period, an amount calculated in accordance with the following formula:

TIER	MEASURED PERFORMANCE RATIO	AMOUNT OF LIQUIDATED DAMAGES PER MPR ASSESSMENT PERIOD
Tier 1	GPR Performance Metric x DF x 0.95 > Measured Performance Ratio ≥ GPR Performance Metric x DF x 0.90	For each one-tenth of one percent (0.001) by which the Measured Performance Ratio for such MPR Assessment Period falls below the upper limit of the bandwidth specified in this subparagraph, an amount equal to one-tenth of one percent (0.001) of the MPR Assessment Period Lump Sum Payment. The upper end of the aforementioned bandwidth is equal to the product of the GPR Performance Metric, the applicable degradation factor (DF), and 95%. The lower limit of the aforementioned bandwidth consists of and includes the product of the GPR Performance Metric, the applicable degradation factor (DF), and 90%; plus
Tier 2	GPR Performance Metric x DF x 0.90 > Measured Performance Ratio ≥ GPR Performance Metric x DF x 0.80 Measured Performance Ratio < GPR Performance Metric x DF x 0.80	For each one-tenth of one percent (0.001) by which the Measured Performance Ratio for such MPR Assessment Period falls below the upper limit of the bandwidth specified in this subparagraph, an amount equal to two-tenths of one percent (0.002) of the MPR Assessment Period Lump Sum Payment. The upper end of the aforementioned bandwidth is equal to the product of the GPR Performance Metric, the applicable degradation factor (DF), and 90%. The lower limit of the aforementioned bandwidth consists of and includes the product of the GPR Performance Metric, the applicable degradation factor (DF), and 80%; plus For each one-tenth of one percent (0.001) by which the Measured Performance Ratio for such MPR Assessment Period falls below the product of the GPR Performance Metric, the applicable degradation factor (DF), and 80%, an amount equal to four-tenths of one percent (0.004) of the MPR Assessment Period Lump Sum Payment.

For purposes of the foregoing calculations under this Section 2. (Measured Performance Metric; Liquidated Damages; Termination Rights), the degradation factor (DF) is calculated for each Contract Year (e.g., second Contract Year, third Contract Year, fourth Contract Year, etc.) as follows: $DF = 1 - 0.005 * (\text{Applicable Contract Year} - 1)$. For purposes of the foregoing formula, the "Applicable Contract Year" is the Contract Year within which the calendar month in question falls. If all of the months of an MPR Assessment Period fall within the same Contract Year, the Contract Year is the "Applicable Contract Year." For example, if all of the months of MPR Assessment Period fall within the third Contract Year, the value assigned to the "Applicable Contract Year" would be "3" and the formula for calculating the DF for such LD Period would be: $DF = 1 - 0.005 * (3 - 1)$. However, because the MPR Assessment Period is a rolling 12-month period, the MPR Assessment Period will often straddle two consecutive Contract Years. In such cases, all of the months falling within the same Contract Year will be assigned the value for such Contract Year and the value assigned to the "Applicable Contract Year" for

purposes of the foregoing formula shall be the average of the assigned monthly values for such 12-month MPR Assessment Period. For example, for an MPR Assessment Period which has four months in the third Contract Year and eight months in the fourth Contract Year, the value assigned to the "Applicable Contract Year" for such MPR Assessment Period would be 3.67, as calculated as follows:

$$(3X4) + (4X8)$$

12

And the formula for calculating the DF for such MPR Assessment Period would be $DF = 1 - 0.005 * (3.67 - 1)$. For purposes of determining liquidated damages under this Section 2. (Measured Performance Metric; Liquidated Damages; Termination Rights). The amount by which the Measured Performance Ratio for the MPR Assessment Period in question falls below the applicable threshold shall be rounded to the nearest one-tenth of one percent (0.001). Each Party agrees and acknowledges that (i) the damages that Company would incur if the Subscriber Organization fails to achieve the GPR Performance Metric for a MPR Assessment Period would be difficult or impossible to calculate with certainty and (ii) the aforesaid liquidated damages are an appropriate approximation of such damages.

EXAMPLE: The following is an example calculation of liquidated damages for the GPR Performance Metric and is included for illustrative purposes only. Assume the following facts:

- The MPR Assessment Period has five months in the second Contract Year and seven months in the third Contract Year.
- The GPR for the Facility as determined by the OEPR is 0.9.
- The MPR has been calculated to be 0.694.
- Applicable Contract Year = $[(5 \times 2) + (7 \times 3)]/12 = 2.58$
- $DF = 1 - 0.005 * (2.58 - 1) = 0.9921$
- Upper limit of the Tier 1 bandwidth = $0.9 \times 0.9921 \times 0.95 = 0.848$
- Lower limit of the Tier 1 bandwidth/Upper limit of the Tier 2 bandwidth = $0.9 \times 0.9921 \times 0.9 = 0.804$
- Lower limit of the Tier 2 bandwidth = $0.8 \times 0.9921 \times 0.9 = 0.714$
- $LD = [((0.848 - 0.804) \times 1) + ((0.804 - 0.714) \times 2) + ((0.714 - 0.694) \times 4)] \times \text{MPR Assessment Period Lump Sum Payment} = 0.304 \times \text{MPR Assessment Period Lump Sum Payment}$

E. MPR Termination Rights. The Parties acknowledge that, although the intent of the liquidated damages payable under is to compensate Company for the damages that Company would incur if the Subscriber Organization fails to achieve the GPR Performance Metric for a MPR Assessment Period, such liquidated damages are not intended to compensate Company for the damages that Company would incur if a pattern of underperformance establishes a reasonable expectation that the Facility is likely to continue to substantially underperform the GPR Performance Metric. Accordingly, and without limitation to Company's rights under said Section 2. (Measured Performance Metric; Liquidated Damages; Termination Rights) for those MPR Assessment Periods during which the Subscriber Organization failed to achieve the GPR Performance Metric, the failure of the PV System to achieve, for each of three consecutive Contract Years, a Measured Performance Ratio of not less than the Tier 2 Bandwidth for such Contract Year shall constitute an Event of Default under Section 13.A.4. Of this Contract for which Company shall have the rights (including but not limited to the termination rights) set forth in Section 13. (Events of Default) and Section 15. (Damages in the Event of Termination by Company).

3. BESS CAPACITY TEST; LIQUIDATED DAMAGES; TERMINATION RIGHTS.

A. BESS Capacity Test and Liquidated Damages. For each BESS Measurement Period following the Commercial Operations Date, the BESS shall be required to complete a BESS Capacity Test, as more fully set forth in Section 1. (BESS Tests) to Attachment H (BESS Requirement) to this Contract. For each BESS Measurement Period for which the BESS fails to demonstrate that it satisfies the BESS Capacity Performance Metric, Subscriber Organization shall pay, in accordance with Attachment C Section 8. (Payment of Liquidated Damages for Failure to Achieve Performance Metrics; Limitation on Liquidated Damages), and Company shall accept, as liquidated damages for such shortfall, the amount set forth in the following table (on a progressive basis) upon proper demand at the end the BESS Measurement Period in question:

BESS Capacity Ratio	Liquidated Damage Amount
Tier 1 95.0% - 99.9%	For each one-tenth of one percent (0.001) that the BESS Capacity Ratio is below 100% and is equal to or greater than 95.0%, an amount equal to one-tenth of one percent (0.001) of the BESS Allocated Portion of the Lump Sum Payment for the BESS Measurement Period in question; plus
Tier 2 85.0% - 94.9%	For each one-tenth of one percent (0.001) that the BESS Capacity Ratio is below 95% and is above 84.9%, an amount equal to one and a half-tenths of one percent (0.0015) of the BESS Allocated Portion of the Lump Sum Payment for the BESS Measurement Period in question; plus
Tier 3 75.0% - 84.9%	For each one-tenth of one percent (0.001) that the BESS Capacity Ratio is below 85% and is above 74.9%, an amount equal to two-tenths of one percent (0.002) of the BESS Allocated Portion of the Lump Sum Payment for the BESS Measurement Period in question; plus
Tier 4 60.0% - 74.9%	For each one-tenth of one percent (0.001) that the BESS Capacity Ratio is below 75% and is above 59.9%, an amount equal to two and a half-tenths of one percent (0.0025) of the BESS Allocated Portion of the Lump Sum Payment for the BESS Measurement Period in question; plus
Tier 5 50.0% - 59.9%	For each one-tenth of one percent (0.001) that the BESS Capacity Ratio is below 60% and is above 49.9%, an amount equal to three-tenths of one percent (0.003) of the BESS Allocated Portion of the Lump Sum Payment for the BESS Measurement Period in question; plus
Tier 6 49.9% and below ("Lowest BESS Capacity Bandwidth")	For each one-tenth of one percent (0.001) that the BESS Capacity Ratio is below 50%, an amount equal to three and a half-tenths of one percent (0.0035) of the BESS Allocated Portion of the Lump Sum Payment for the BESS Measurement Period in question.

For purposes of determining liquidated damages under this Section 3. (BESS Capacity Test and Liquidated Damages), the starting and end points for the duration of the period that the BESS discharges shall be rounded to the nearest MWh. Each Party agrees and acknowledges that (i) the damages that Company would incur if the Subscriber Organization fails to achieve the BESS Capacity Performance Metric for a BESS Measurement Period would be difficult or impossible to calculate with certainty and (ii) the aforesaid liquidated damages are an appropriate approximation of such damages.

EXAMPLE: The following is an example calculation of liquidated damages for the BESS Capacity Performance Metric and is included for illustrative purposes only. Assume the following:

- The Maximum Rated Output for the BESS is 25 MW.
- A BESS Capacity Test was conducted, and the BESS was measured to have discharged 65 MWh
- BESS Contract Capacity = 25 MW x 4 hours = 100 MWh
- BESS Capacity Ratio = MWh Discharged/BESS Contract Capacity = 65 MWh/100 MWh = 0.65

- $LD = [(1 - 0.950) \times 1] + [(0.950 - 0.850) \times 1.5] + [(0.850 - 0.750) \times 2] + [(0.750 - 0.65) \times 2.5] \times \text{BESS Allocated Portion of the Lump Sum Payment for the BESS Measurement Period in question} = 0.65 \times \text{BESS Allocated Portion of the Lump Sum Payment for the BESS Measurement Period in question}.$

B. BESS Capacity Test Termination Rights. The Parties acknowledge that, although the intent of the liquidated damages payable under Section 3. (BESS Capacity Test and Liquidated Damages) is to compensate Company for the damages that Company would incur if the BESS fails to demonstrate satisfaction of the BESS Capacity Performance Metric during a BESS Measurement Period, such liquidated damages are not intended to compensate Company for the damages that Company would incur if a pattern of underperformance establishes a reasonable expectation that the BESS is likely to continue to substantially underperform the Company's expectations. Accordingly, and without limitation to Company's rights under said Section 3. (BESS Capacity Test and Liquidated Damages) for those BESS Measurement Periods during which the BESS fails to demonstrate satisfaction of the BESS Capacity Performance Metric, substantial underperformance shall give rise to a termination right as set forth in this Section 3.B. (BESS Capacity Test Termination Rights). If the BESS is in the Lowest BESS Capacity Bandwidth for any two BESS Measurement Periods during a 12-month period, an 18-month cure period (the "BESS Capacity Cure Period") will commence on the Day following the close of the second such BESS Measurement Period. For each BESS Measurement Period during such BESS Capacity Cure Period, BESS Capacity Tests shall continue to be conducted as set forth in Attachment H (BESS Requirements) to this Contract and liquidated damages paid and accepted as set forth in Section 3. (BESS Capacity Test and Liquidated Damages); provided, however, that if the Subscriber Organization fails to demonstrate satisfaction of the BESS Capacity Performance Metric prior to the expiration of the BESS Capacity Cure Period, such failure shall constitute an Event of Default under this Contract for which Company shall have the rights (including but not limited to the termination rights) set forth in Section 13. (Events of Default) Section 14. (Termination for Cause) and Section 15. (Damages in the Event of Termination by Company).

4. BESS ANNUAL EQUIVALENT AVAILABILITY FACTOR; LIQUIDATED DAMAGES; TERMINATION RIGHTS.

A. BESS Annual Equivalent Availability Factor and Liquidated Damages. For each BESS Measurement Period following the Commercial Operations Date, a BESS Annual Equivalent Availability Factor shall be calculated as set forth in Section 2. (BESS Annual Equivalent Availability Factor) of Attachment H. (BESS Requirements). If the BESS Annual Equivalent Availability Factor for such BESS Measurement Period is less than 97% (the "BESS EAF Performance Metric"), Subscriber Organization shall pay, in accordance with Attachment C Section 8. (Payment of Liquidated Damages for Failure to Achieve Performance Metrics; Limitation on Liquidated Damages), and Company shall accept, as liquidated damages for such shortfall, the amount set forth in the following table (on a progressive basis) upon proper demand at the end the current BESS Measurement Period:

BESS Annual Equivalent Availability Factor	Liquidated Damage Amount
Tier 1 85.0% - 96.9%	For each one-tenth of one percent (0.001) by which the BESS Annual Equivalent Availability Factor falls below 97% but equal to or above 85%, an amount equal to one-tenth of one percent (0.001) of the BESS Allocated Portion of the Lump Sum Payment for the BESS Measurement Period in question; plus
Tier 2 80.0% - 84.9%	For each one-tenth of one percent (0.001) by which the BESS Annual Equivalent Availability Factor falls below 85% but equal to or above 80%, an amount equal to two-tenths of one percent (0.002) of the BESS Allocated Portion of the Lump Sum Payment for the BESS Measurement Period in question; plus
Tier 3 75.0% - 79.9%	For each one-tenth of one percent (0.001) by which the BESS Annual Equivalent Availability Factor falls below 80% but equal to or above 75%, an amount equal to three-tenths of one percent (0.003) of the BESS Allocated Portion of the Lump Sum Payment for the BESS Measurement Period in question; plus

<p>Tier 4 Below 75.0%</p>	<p>For each one-tenth of one percent (0.001) by which the BESS Annual Equivalent Availability Factor falls below 75%, an amount equal to four-tenths of one percent (0.004) of the BESS Allocated Portion of the Lump Sum Payment for the BESS Measurement Period in question.</p>
---	--

For purposes of determining liquidated damages under this Section 4. (BESS Annual Equivalent Availability Factor and Liquidated Damages), the BESS Annual Equivalent Availability Factor for the BESS Measurement Period in question shall be rounded to the nearest one-tenth of one percent (0.001). Each Party agrees and acknowledges that (i) the damages that Company would incur if the Subscriber Organization fails to achieve the BESS EAF Performance Metric for a BESS Measurement Period would be difficult or impossible to calculate with certainty and (ii) the aforesaid liquidated damages are an appropriate approximation of such damages.

EXAMPLE: The following is an example calculation of liquidated damages for the BESS Annual Equivalent Availability Factor Performance Metric and is included for illustrative purposes only. Assume the following:

The monthly Lump Sum Payment is \$1,000,000

The BESS Annual Equivalent Availability Factor Performance Metric was calculated to be 72.9%.

BESS Allocated Portion of the Lump Sum Payment = 50% x 3 calendar months x \$1,000,000 = \$1,500,000

LD = $[(0.970-0.850) \times 1] + [(0.850-0.800) \times 2] + [(0.800-0.750) \times 3] + [(0.750-0.729) \times 4] \times \$1,500,000$

= $[0.120 + 0.100 + 0.150 + 0.084] \times \$1,500,000 = \$681,000$

B. BESS Annual Equivalent Availability Factor Termination Rights. The Parties acknowledge that, although the intent of the liquidated damages payable under Section 4. (BESS Annual Equivalent Availability Factor and Liquidated Damages) is to compensate Company for the damages that Company would incur if the Subscriber Organization fails to achieve the BESS EAF Performance Metric for a BESS Measurement Period, such liquidated damages are not intended to compensate Company for the damages that Company would incur if a pattern of underperformance establishes a reasonable expectation that the BESS is likely to continue to substantially underperform the BESS EAF Performance Metric. Accordingly, and without limitation to Company's rights under said Section 4. (BESS Annual Equivalent Availability Factor and Liquidated Damages) for those BESS Measurement Periods during which the Subscriber Organization failed to achieve the BESS EAF Performance Metric, the failure of the Subscriber Organization to achieve, for each of four consecutive BESS Measurement Periods, a BESS Annual Equivalent Availability Factor of not less than 75%; shall constitute an Event of Default under Section 13.A. of this Contract for which Company shall have the rights (including but not limited to the termination rights) set forth in Section 13. (Events of Default) Section 14. (Termination for Cause) and Section 15. (Damages in the Event of Termination by Company); provided, however, that if a BESS Measurement Period for which the aforementioned 75% threshold is not achieved falls within a BESS Capacity Cure Period, such BESS Measurement Period shall be excluded from the calculation of the aforementioned "four consecutive BESS Measurement Periods" if the failure to achieve the aforementioned 75% threshold was the result of unavailability caused by the process of carrying out the repairs to or replacements of the BESS necessary to remedy the failure of the BESS to achieve the BESS Capacity Performance Metric.

5. BESS ANNUAL EQUIVALENT FORCED OUTAGE FACTOR; LIQUIDATED DAMAGES.

A. For each BESS Measurement Period following the Commercial Operations Date, the BESS shall maintain a BESS Annual Equivalent Forced Outage Factor of not more than 4% (the "BESS EFOF Performance Metric") as calculated as set forth in Section 5. (BESS Annual Equivalent Forced Outage Factor). If the BESS Annual Equivalent Forced Outage Factor for such BESS Measurement Period exceeds the BESS EFOF

Performance Metric, Subscriber Organization shall pay, in accordance with Attachment C Section 8. (Payment of Liquidated Damages for Failure to Achieve Performance Metrics; Limitation on Liquidated Damages), and Company shall accept, as liquidated damages for exceeding the BESS EFOF Performance Metric, the amount set forth in the following table (on a progressive basis) upon proper demand by the Company at the end of the BESS Measurement Period in question:

BESS Annual Equivalent Forced Outage Factor	Liquidated Damage Amount
0.0% - 4.0%	-0-
4.1% - 6.9%	For each one-tenth of one percent (0.001) that the BESS Annual Equivalent Forced Outage Factor is above 4.0% but less than 7.0%, an amount equal to two-tenths of one percent (0.002) of the BESS Allocated Portion of the Lump Sum Payment for the BESS Measurement Period in question; plus
7.0% and above	For each one-tenth of one percent (0.001) that the BESS Annual Equivalent Forced Outage Factor is above 6.9%, an amount equal to four-tenths of one percent (0.004) of the BESS Allocated Portion of the Lump Sum Payment for the BESS Measurement Period in question

For purposes of determining liquidated damages under this Attachment C Section 5. (BESS Annual Equivalent Forced Outage Factor; Liquidated Damages), the BESS Annual Equivalent Forced Outage Factor for the BESS Measurement Period in question shall be rounded to the nearest one-tenth of one percent (0.001). Each Party agrees and acknowledges that (i) the damages that Company would incur if the Subscriber Organization fails to achieve the BESS EFOF Performance Metric for a BESS Measurement Period would be difficult or impossible to calculate with certainty and (ii) the aforesaid liquidated damages are an appropriate approximation of such damages.

For example, if the BESS Equivalent Annual Forced Outage Factor was 4.1% as calculated in the example in Section 5. (BESS Annual Equivalent Forced Outage Factor) attached hereto and the BESS Allocated Portion of the Lump Sum Payment for the BESS Measurement Period in question is \$1,000,000, the liquidated damages would be \$2,000, calculated as follows:

- 4.1% - 4.0% = 0.1%
- 0.1%/0.1 = 1
- \$1,000,000 x .002 = \$2,000
- \$2,000 x 1 = \$2,000

6. BESS ROUND TRIP EFFICIENCY TEST; LIQUIDATED DAMAGES; TERMINATION RIGHTS.

A. RTE Test and Liquidated Damages. For each BESS Measurement Period following the Commercial Operations Date, the BESS shall be required to complete an RTE Test or otherwise demonstrate satisfaction of the RTE Performance Metric, as more fully set forth in Attachment H (BESS Requirements) to this Contract. For each BESS Measurement Period for which the BESS fails to demonstrate that it satisfies the RTE Performance Metric, Subscriber Organization shall pay, in accordance with Attachment C Section 8. (Payment of Liquidated Damages for Failure to Achieve Performance Metrics; Limitation on Liquidated Damages), and Company shall accept, as liquidated damages for such shortfall, in the amount to be calculated as provided in this Section 6.A. (RTE Test and Liquidated Damages) and in Attachment B

(Company Payments for Energy, Dispatchability and Availability of Bess), upon proper demand at the end of the BESS Measurement Period in question.

The RTE Performance Metric is %. The RTE Performance Metric represents the lowest acceptable efficiency of the BESS for a full charge and discharge cycle if all energy to achieve the full cycle was taken from and delivered to the Point of Interconnection. **[DRAFTING NOTE: PERCENTAGE TO BE TAKEN FROM RESPONSE TO RFP. The metric will remain a “theoretical” POI to POI worse acceptable performance, even though the intake energy measurement used in the RTE test will move electrically closer to the BESS. This is in the Subscriber Organization's favor, as it can expect to gain efficiency (less losses) by moving the intake energy measurement point closer to the BESS as is proposed in Attachment H.]]**

The liquidated damages threshold ("LDT") is equal to the RTE Performance Metric minus 2 percentage points.

The Selected RTE Test is the RTE Test most recently completed during the BESS Measurement Period in question.

Subscriber Organization shall be liable for liquidated damages if:

$$(PM - RTE Ratio) * 100 > 2\%$$

Where:

PM = RTE Performance Metric stated as percentage

RTE Ratio = RTE Ratio from Selected RTE Test stated as percentage

For each percentage point by which the RTE Ratio is below the LDT, Subscriber Organization shall pay, and Company shall accept, liquidated damages in an amount equal to two-tenths of one percent (0.002) of the BESS Allocated Portion of the Lump Sum Payment for the BESS Measurement Period in question.

Each Party agrees and acknowledges that (i) the damages that Company would incur if the Subscriber Organization fails to achieve the RTE Performance Metric for a BESS Measurement Period would be difficult or impossible to calculate with certainty and (ii) the aforesaid liquidated damages are an appropriate approximation of such damages.

- B. RTE Test Termination Rights.** The Parties acknowledge that, although the intent of the liquidated damages payable under Section 6.A. (RTE Test and Liquidated Damages) is to compensate Company for the damages that Company would incur if the BESS fails to demonstrate satisfaction of the RTE Performance Metric during a BESS Measurement Period, such liquidated damages are not intended to compensate Company for the damages that Company would incur if a pattern of underperformance establishes a reasonable expectation that the BESS is likely to continue to substantially underperform the Company's expectations. Accordingly, and without limitation to Company's rights under said Section 6. A. (RTE Test and Liquidated Damages) for those BESS Measurement Periods during which the BESS fails to demonstrate satisfaction of the RTE Performance Metric, substantial underperformance shall give rise to a termination right as set forth in this Section 6.B. (RTE Test Termination Rights). If the RTE Ratio for the Selected RTE Test for the BESS Measurement Period in question is more than 15 percentage points below the RTE Performance Metric for any two BESS Measurement Periods during a 12-month period, an 18-month cure period (the "RTE Cure Period") will commence on the Day following the close of the second such BESS Measurement Period. For each BESS Measurement Period during such RTE Cure Period, RTE Tests shall continue to be conducted as set forth in Attachment H (BESS Requirements) and liquidated damages paid and accepted as set forth in Section 6.A. (RTE Test and Liquidated Damages); provided, however, that if the Subscriber Organization fails to demonstrate satisfaction of the RTE Performance

Metric prior to the expiration of the RTE Cure Period, such failure shall constitute an Event of Default under Section 13 of this Contract for which Company shall have the rights (including but not limited to the termination rights) set forth in Section 13 (Events of Default) and Section 15 (Damages in the Event of Termination by Company) of this Contract.

7. **[RESERVED]**

8. **PAYMENT OF LIQUIDATED DAMAGES FOR FAILURE TO ACHIEVE PERFORMANCE METRICS; LIMITATION ON LIQUIDATED DAMAGE.**

A. Payment of Performance Metrics LDs by Subscriber Organization. With respect to the liquidated damages payable under Section 1 (PV System Equivalent Availability Factor Performance Metric and Liquidated Damages), Section 2 (Measured Performance Metric; Liquidated Damages; Termination Rights) Section 3 (BESS Capacity Test and Liquidated Damages), Section 4 (BESS Annual Equivalent Availability Factor and Liquidated Damages), Section 5 (BESS Annual Equivalent Forced Outage Factor; Liquidated Damages) and Section 6 (BESS Round Trip Efficiency Test; Liquidated Damages; Termination Rights) (collectively, the "Performance Metrics LDs"), Company shall have the right, at any time on or after the LD Assessment Date for the liquidated damages in question, at Company's option, to set-off such liquidated damages from the amounts to be paid to Subscriber Organization for the Unsubscribed RDG or, to draw such liquidated damages from the Operating Period Security, as follows:

1. if the BESS fails to achieve the BESS Capacity Performance Metric for a BESS Measurement Period, the Company shall have the right to set-off or draw the amount owed for such failure as calculated as provided in Section 3 (BESS Capacity Test and Liquidated Damages); and
2. if the Monthly Report for the calendar month, MPR Assessment Period, or BESS Measurement Period in question, as applicable, shows a failure to achieve one or more of the Performance Metrics required for the LD Period in question, the MPR Measurement Period in question, or the BESS Measurement Period in question, as applicable, and Company does not submit a Notice of Disagreement with respect to such Monthly Report, the Company shall have the right to set-off or draw the amount of liquidated damages owed for such failure as calculated as provided in Section 1 (PV System Equivalent Availability Factor Performance Metric and Liquidated Damages), Section 2 (Measured Performance Metric; Liquidated Damages; Termination Rights) Section 3 (BESS Capacity Test and Liquidated Damages), Section 4 (BESS Annual Equivalent Availability Factor and Liquidated Damages), Section 5 (BESS Annual Equivalent Forced Outage Factor; Liquidated Damages) and Section 6 (BESS Round Trip Efficiency Test; Liquidated Damages; Termination Rights) as applicable;
3. in all cases in which Company submits a Notice of Disagreement for a given Monthly Report, Company shall have the right to set-off or draw all or any portion of the amount of liquidated damages for the calendar month in question, MPR Assessment Period in question, or BESS Measurement Period in question, as applicable, as calculated on the basis of the shortfall(s) in the achievement of the Performance Metric(s) in question, as shown in such Notice of Disagreement; and
4. in the event of any disagreement as to the liquidated damages owed under clause --and --above:
 - a. if the amount set-off or drawn by the Company exceeds the amount of liquidated damages for such calendar month, BESS Measurement Period or MPR Assessment Period that are eventually found to be payable for the LD Period in question as determined under Section 2 (Monthly Report Disagreements) of Attachment E (Monthly Reporting and Dispute Resolution by Independent AF Evaluator) to this Contract, Company shall promptly (and in no event more than forty-five (45) Business Days from the date of such determination) repay such excess to Subscriber Organization together with, unless the Parties otherwise agree in writing, interest from the date of Company's set-off or draw until the date that such excess is repaid to Subscriber Organization at the average Prime Rate for such period; and
 - b. if Company does not exercise its rights to set-off or draw liquidated damages for such calendar month, BESS Measurement Period or MPR Assessment Period, or does not set-off or draw the

full amount of the liquidated damages for such calendar month, BESS Measurement Period or MPR Assessment Period that are eventually found to be payable for the LD Period, BESS Measurement Period or MPR Assessment Period in question as determined under Section 2. (Monthly Report Disagreements) of Attachment E (Monthly Reporting and Dispute Resolution by Independent AF Evaluator) to this Contract, Subscriber Organization shall promptly, upon such determination as aforesaid, pay to Company the amount of liquidated damages that are found to be owing together with, unless otherwise agreed by the Parties in writing, interest on the amount of such liquidated damages that went unpaid from the applicable LD Assessment Date for such liquidated damages until the date such liquidated damages are paid to Company in full at the average Prime Rate for such period, and Company shall have the right, at its option, to set-off such interest from the amounts to be paid to Subscriber Organization for the Unsubscribed RDG or to draw from the Operating Period Security.

Any delay by Company in exercising its rights to set-off liquidated damages and/or interest from the amounts to be paid to Subscriber Organization for the Unsubscribed RDG or to draw such liquidated damages and/or interest from the Operating Period Security shall not constitute a waiver by Company of its right to do so.

- B.** Limitation on Liquidated Damages. Notwithstanding any other provision of this Contract to the contrary, the aggregate liquidated damages paid by Subscriber Organization during each Contract Year for the Performance Metrics LDs, such payments by Subscriber Organization to include but not be limited to any set-offs or draws made by Company during such Contract Year pursuant to Section 8 A. (Payment of Performance Metrics LDs by Subscriber Organization) of this Attachment C (Required Performance Metrics; Liquidated Damages), shall not exceed the total of the twelve (12) monthly Lump Sum Payments payable during such Contract Year pursuant to Section 4.B. (Lump Sum Payment) and Section 4.G. (Payment Procedures) of the Contract. For avoidance of doubt: A monthly Lump Sum Payment that is invoiced by Subscriber Organization to Company pursuant to Section 4.F. (Subscriber Organization's Preparation of the Monthly Invoice) for, e.g., the twelfth (12th) calendar month of Contract Year N but is paid during Contract Year N+1 as provided in Section 4.G (Payment Procedures) shall, for purposes of determining the limitation on Performance Metrics LDs under this Section 8.B. (Limitation on Liquidated Damages) of Attachment C (Required Performance Metrics; Liquidated Damages), be included in the total of the twelve (12) monthly Lump Sum Payments payable during Contract Year N+1. As a result of the foregoing, the total of the monthly Lump Sum Payments used to establish the limitation on Performance Metrics LDs for the initial Contract Year under this Section 8.B. (Limitation on Liquidated Damages) of Attachment C (Required Performance Metrics; Liquidated Damages) will be less than twelve (12). The Parties acknowledge that, because the monthly Lump Sum Payment is subject to adjustment (including downward adjustment) as provided in Section 4.B. of the Contract (Lump Sum Payment), it is possible that a downward adjustment in some or all of the monthly Lump Sum Payments payable during a Contract Year might cause the Performance Metrics LDs paid by Subscriber Organization during the course of such Contract Year to exceed the limitation on the Performance Metrics LDs for such Contract Year established at the close of such Contract Year pursuant to the first sentence of this Section 8.B. (Limitation on Liquidated Damages). In such case, Company shall promptly upon the determination that the Performance Metrics LDs paid during the course of such Contract Year exceeded the limitation on Performance Metrics LDs for such Contract Year (and in no event more than forty-five (45) Business Days from the end of such Contract Year) repay such excess amount to Subscriber Organization without interest.
- C.** Payment of Shortfall Performance Metrics LDs by Reduction of Bill Credits.
1. If Performance Metrics LDs remain unpaid after Company has exercised its rights under Attachment C Section 8. A. (Payment of Performance Metrics LDs by Subscriber Organization) to set off such liquidated damages from the amounts to be paid to Subscriber Organization and to draw such liquidated damages from the Operating Period Security, the Company shall have the right to pay such unpaid Performance Metrics LDs ("Shortfall Performance Metrics LDs") by reducing Bill Credits in the aggregate amount of such unpaid Shortfall Performance Metrics LDs. The reduction in Bill Credits shall

be proportionate so that the burden of paying the Shortfall Performance Metrics LDs is shared equitably among the Subscribers.

2. In the event of any disagreement under Attachment C Section 8.A. (Payment of Performance Metrics LDs by Subscriber Organization) as to the amount of liquidated damages owing:
 - a. Upon the resolution of such disagreement pursuant to Section 2. (Monthly Report Disagreements) of Attachment E (Monthly Reporting and Dispute Resolution by Independent AF Evaluator) to this Contract, if such resolution has the effect of reducing the Shortfall Performance Metrics LDs, and if such reduction in the Shortfall Performance Metrics LDs has the effect of causing the reduction in Bill Credits previously implemented by Company to exceed the actual amount of the Shortfall Performance Metrics LDs (the amount of such excess being referred to herein on the "Excess Reduction in Bill Credits"), Company shall promptly (and in no event later than the second billing cycle for each Subscriber following the date of the resolution of such disagreement as aforesaid) afford to such Subscriber a Bill Credit (referred to herein as a "Compensatory Bill Credit") in an amount equivalent to the total of (i) such Subscriber's proportionate share of the Excess Reduction in Bill Credits and (ii), unless the Company and Subscriber Organization otherwise agree in writing as provided Section 4.A., interest on the amount of the Excess Reduction in Bill Credits from the date Company implemented such Excess Reduction in Bill Credits with respect to such Subscriber until the date that Company applies the Compensatory Bill Credit against such Subscriber's retail electric service bill, at the average Prime Rate for such period; and upon the resolution of such disagreement pursuant to Section 2. (Monthly Report Disagreements) of Attachment E (Monthly Reporting and Dispute Resolution by Independent AF Evaluator) to this Contract, if Company has not previously exercised -its rights to set-off or draw liquidated damages pursuant to Section 8.A. (Payment of Performance Metrics LDs by Subscriber Organization), or has not previously set-off or drawn from the Performance Security the full amount of the liquidated damages that are eventually found to be payable as a result of the resolution of such disagreement, ,Company shall have the right to reduce Subscriber Bill Credits in an amount equal to the total of Subscribers' share of pay such Shortfall Performance Metrics LDs.

--END--

ATTACHMENT D

CALCULATION AND ADJUSTMENT OF NET ENERGY POTENTIAL

1. NET ENERGY POTENTIAL.

A. Net Energy Potential and the Intent of the Parties. The essence of this Attachment D is that Company is paying to Subscriber Organization a Lump Sum Payment in exchange for Company's right to dispatch, subject to Renewable Resource Variability, the Facility's Net Energy Potential. Under this Attachment D, "Net Energy Potential": (i) constitutes an estimated single number with a P-Value of 95 for annual Net Energy that could be produced by the Facility based on the estimated long-term monthly and annual total of such production over a period of ten years excluding losses due to availability and Company Dispatch; (ii) is subject to adjustment from time to time as provided in this Attachment D (Calculation and Adjustment of Net Energy Potential); and (iii) as so adjusted, provides a basis for calculating and adjusting the Lump Sum Payment, as provided in Section 3. (Calculation of Lump Sum Payment) of Attachment B (Company Payments for Energy, Dispatchability and Availability of BESS) to the Contract. The Net Energy Potential shall be calculated using, but not limited to, long-term resource data correlated with on-site measurements (if available), the most current construction design and equipment specifications, and industry-accepted energy simulation models. Loss factors and uncertainty analysis are to be determined using industry best practices and standard assumptions. Loss factors shall include, but not be limited to, electrical losses. Loss factors will exclude losses due to availability and Company Dispatch. In the case of the Initial OEPR and any Subsequent OEPR evaluation, the Net Energy Potential shall also consider historical operational data further described in this Attachment D Section 2.E). It is the intent of the Parties that the estimate of Net Energy Potential, as calculated and adjusted as foresaid, should reflect the following risk allocation between the Parties under the Contract:

1. Subscriber Organization has assumed the risk of downward adjustment to the Net Energy Potential (and hence the Lump Sum Payment) to account for any of the following circumstances:
 - a. if the Renewable Resource Baseline (as estimated on the basis of the typical meteorological year as derived from the Site's measured meteorological data) is lower than Subscriber Organization had assumed when it submitted its RFP Proposal;
 - b. if the as-built design and construction of the Facility is not as efficient in generating electrical energy and delivering such electric energy to the Point of Interconnection as Subscriber Organization had assumed when it submitted its RFP Proposal; and
 - c. if the Facility's level of operational efficiency is below the standard of comparable facilities;
 - d. Company has assumed the risk of the following (i.e., the following are to be disregarded for purposes of estimating Net Energy Potential (and hence the Lump Sum Payment)):
 - e. Renewable Resource Variability; and
 - f. the possibility that, at any given moment, Company does not need to dispatch any or all of the electric energy that the Facility is then capable of generating and delivering to the Point of Interconnection.
2. The foregoing is not intended as an exhaustive list of the risks assumed by either Party under this Attachment D or as a limitation on the circumstances that an OEPR Evaluator, in its professional judgment, may decide to take into account in preparing its OEPR under Section 2.E. (Terms of Engagement) of this Attachment D (Calculation and Adjustment of Net Energy Potential).

- B. NEP RFP Projection.** In its RFP Proposal, the Subscriber Organization projected that the Facility would have a Net Energy Potential (as defined in this Attachment D) of [REDACTED] MWh [**NOTE – INSERT NEP FROM RFP PROPOSAL**] and provided the plane of array irradiance data used in arriving at the NEP RFP Projection, and Company relied on Subscriber Organization's NEP RFP Projection in deciding to contract with Subscriber Organization in lieu of other developers. Among the fundamentals of the bargain evidenced in this Attachment D is that there will be consequences to Subscriber Organization if (i) the IE Energy Assessment does not support the NEP RFP Projection and/or (ii) the operational performance of the Facility indicates a Net Energy Potential that is below the applicable thresholds set forth in this Attachment D (Calculation and Adjustment of Net Energy Potential).
- C. NEP IE Estimate and Company-Designated NEP Estimate.** Prior to the closing of the construction financing for the Facility but in no event later than the Commercial Operations Date, the Subscriber Organization shall provide Company with a copy of the IE Energy Assessment Report and the data on plane of array irradiance and corresponding power output used in arriving at the NEP IE Estimate. In addition, Subscriber Organization shall obtain from the administrative agent of the Facility Lender and provide to Company, at financial close of the construction debt financing, a confirmation letter confirming to Company that the IE Energy Assessment Report including the data on plane of array of irradiance and corresponding power output used in arriving at the NEP IE Estimate provided by Subscriber Organization to Company is the final energy assessment prepared for the Facility Lender as part of the Facility Lender's due diligence leading up to the Facility Lender's legally binding commitment (subject to certain conditions precedent) to provide a specific amount of financing for the Project as evidenced by the Facility Lender's execution of the Financing Documents. If the IE Energy Assessment Report fails to provide a NEP IE Estimate that is consistent with the requirements of this Attachment D in all material respects, or if the data on plane of array of irradiance and corresponding power output used in arriving at the NEP IE Estimate is not provided, or if the aforementioned confirmation letter is not provided, Company shall have the option, exercisable by written notice to Subscriber Organization issued no later than 30 Days, or such longer period as the Parties may agree in writing, following the first to occur of Company's receipt of (i) the IE Energy Assessment Report or (ii) notice that Company will not be provided with a copy of the IE Energy Assessment Report and the data on plane of array of irradiance, ambient temperature, wind speed and corresponding power output used in arriving at the NEP IE Estimate, to designate such Company-Designated NEP Estimate as Company, in its sole discretion, determines to be reasonable in light of the information then available to Company. In connection with Company's decision as to whether to designate a Company-Designated NEP Estimate, Company shall have the right to require Subscriber Organization to pay for an energy assessment to be performed by an independent engineer selected by Company. In such case, the aforesaid 30-Day period for Company's decision to designate a Company-Designated NEP Estimate shall be tolled for the time necessary to prepare such assessment. If Company fails, within the aforesaid 30-Day period as such period may be tolled as provided in the preceding sentence, to designate a Company-Designated NEP Estimate, the NEP RFP Projection shall constitute the First NEP Benchmark, unless the Parties agree in writing on a lower First NEP Benchmark.
- D. NEP IE Estimate, Liquidated Damages and Subscriber Organization's Null and Void Right.** If the NEP IE Estimate is higher than the NEP RFP Projection, the NEP RFP Projection shall constitute the First NEP Benchmark. In any other case, Subscriber Organization shall have the option to declare the Contract null and void by written notice to Company as follows:
1. if (aa) the NEP IE Estimate is lower than the NEP RFP Projection and (bb) Subscriber Organization issues its null and void notice to Company not later than 30 Days after issuance of the IE Energy Assessment Report; or
 2. if (aa) Company exercises its right to designate a Company-Designated NEP Estimate under Section 1. C. (NEP IE Estimate and Company-Designated NEP Estimate) of this Attachment D (Calculation and Adjustment of Net Energy Potential), (bb) such Company-Designated NEP Estimate is lower than the NEP RFP Projection, and (cc) Subscriber Organization issues its null and void notice to Company not later than 30 Days after Company's notice of the Company-Designated NEP Estimate.

3. If Subscriber Organization fails to declare this Contract null and void under the conditions set forth in either clause (1) or clause (2) above, then: (x) the NEP IE Estimate or the Company-Designated NEP Estimate, as applicable, shall thereafter constitute the First NEP Benchmark and (y) Subscriber Organization shall, within five (5) Business Days following the expiration of the applicable 30-Day period for the issuance of Subscriber Organization's null and void notice, pay liquidated damages equal to \$10 for every MWh by which the NEP RFP Projection exceeds the First NEP Benchmark for the initial Contract Year.
- E. Initial OEPR. Following the Initial NEP Verification Date, the Initial OEPR shall be prepared pursuant to the process set forth in Section 2. (Preparation of OEPR) of this Attachment D (Calculation and Adjustment of Net Energy Potential) and the Initial NEP OEPR Estimate shall be as set forth in or derived from the Initial OEPR, as more fully set forth in Section 2. E. (Terms of Engagement) of this Attachment D (Calculation and Adjustment of Net Energy Potential). If the Initial NEP OEPR Estimate differs from the First NEP Benchmark, the Lump Sum Payment shall be recalculated and adjusted as provided in Section 3.B. (Lump Sum Payment during Second Benchmark Period) of Attachment B (Company Payments for Energy, Dispatchability and Availability of BESS) to the Contract.
- F. Subsequent OEPRS.
1. Required Subsequent OEPR. If Subscriber Organization makes any changes to the Facility that involve (i) replacing any step-up transformer(s) or (ii) making any other changes (e.g., changing the characteristics of the Facility equipment or the specifications used in the IRS) that Company reasonably determines require an updated IRS, then Subscriber Organization shall also be required to have a subsequent OEPR prepared as of the first Day of the calendar month following the second anniversary of the date such change to the Facility was completed.
 2. Voluntary Subsequent OEPR. Without limitation to the generality of Section F.1. (Required Subsequent OEPR) of this Attachment D (Calculation and Adjustment of Net Energy Potential), if the Subscriber Organization makes any changes to the Facility (e.g., replacing original equipment) that does not trigger a required Subsequent OEPR but which changes Subscriber Organization has reasonable grounds to believe will improve the Facility's Net Energy Potential, Subscriber Organization shall have a one-time option, exercisable by written notice to Company issued not less than 120 Days prior to the Applicable NEP Verification Date, of having a subsequent OEPR prepared as of a date no sooner than 12 months following completion of the then most recent OEPR.
 3. Subsequent OEPR and Adjustment to Lump Sum Payment. If the Subsequent NEP OEPR Estimate differs from the Most Recent Prior NEP Benchmark, the Lump Sum Payment shall be recalculated and adjusted as provided in Section 3.B. (Lump Sum Payment Following Second Benchmark Period) of Attachment B (Company Payments for Energy, Dispatchability and Availability of BESS) to the Contract.
2. PREPARATION OF OEPR. The following provisions apply to the Initial OEPR and any Subsequent OEPR:
- A. Selection of OEPR Evaluator. No later than 90 Days prior to the Applicable NEP Verification Date, Company and Subscriber Organization shall select, in accordance with the terms of this Section 2.A. (Selection of OEPR Evaluator), an independent engineering firm from the firms listed on the OEPR Consultants List (the "OEPR Evaluator") to prepare an operational energy production report ("OEPR"). Each party shall select the names of two (2) firms from the OEPR Consultants List. If there is mutual agreement on one or both of the named firms, then the Subscriber Organization shall select one of the named firms to serve as the OEPR Evaluator. If there is no agreement on any of the named firms, then Subscriber Organization shall select one of the firms named by the Company.
 - B. Eligibility for Appointment as OEPR Evaluator. Both Parties agree that the engineering firms listed in Section 2. J. of this Attachment D (Calculation and Adjustment of Net Energy Potential) are fully qualified to prepare the OEPR. By mutual agreement between the Parties in writing, both Parties acting reasonably, a name or

names may be added to or removed from the OEPR Consultants List at any time. In no event shall there be less than three (3) names on the OEPR Consultants List.

- C. OEPR Period of Record. It is the intent of the Parties that the OEPR shall be prepared using measured meteorological and production data from the OEPR Period of Record. However, although the OEPR Period of Record is a twelve-month period, the Parties acknowledge that, in certain circumstances (e.g., Force Majeure), there may not be twelve months of data available for the OEPR Period of Record. In such case, (i) it is the intent of the Parties that the OEPR be prepared using such measured meteorological and production data that is available from the OEPR Period of Record and (ii) Parties may, by written agreement, direct the OEPR Evaluator to use such additional data outside of the OEPR Period of Record as the Parties may agree. The preceding sentence does not constitute a limitation on the professional judgment of the OEPR Evaluator as to the appropriateness of using measured meteorological and/or production from outside of the OEPR Period of Record.
- D. Participation of Parties. Promptly following the Applicable NEP Verification Date, Subscriber Organization and Company shall provide the OEPR Evaluator with such data from the OEPR Period of Record as they consider to be material to the preparation of the OEPR. Subscriber Organization and Company shall also provide such additional data and information as the OEPR Evaluator may reasonably request. The Parties shall assist the OEPR Evaluator throughout the process of preparing the OEPR, including making key personnel and records available to the OEPR Evaluator, but neither Party shall be entitled to participate in any meetings with personnel of the other Party or review of the other Party's records. However, the OEPR Evaluator will have the right to conduct meetings, hearings or oral arguments in which both Parties are represented. Subscriber Organization and Company shall have forty-five (45) Days from issuance of the draft OEPR Report to review and provide feedback to the OEPR Evaluator on such report.
- E. Terms of Engagement. Upon selection of the OEPR Evaluator, as set forth in this Attachment D (Calculation and Adjustment of Net Energy Potential), the Subscriber Organization shall retain and contract with the OEPR Evaluator in accordance with the terms of this Attachment D (Calculation and Adjustment of Net Energy Potential). The OEPR Evaluator's scope of work and expected deliverables for all OEPRs must be acceptable to Company and shall, among other things, require the OEPR Evaluator to provide (i) an estimated single number with a P-Value of 95 for annual Net Energy that could be produced by the Facility based on the estimated long-term monthly and annual total of such production over a period of ten years; (ii) the data on plane of array of irradiance and corresponding power output used in arriving at the aforementioned estimated annual Net Energy; (iii) the GPR Performance Metric as provided in Section 1.E. (Commencing With Initial OEPR) or Section 1.F. (Commencing With First Subsequent OEPR and Thereafter) of this Attachment D, as applicable; and (iv) any additional information that may be reasonably required by a Party with respect to the methodology used by the OEPR Evaluator to reach its conclusion. The provisions of this Attachment D (Calculation and Adjustment of Net Energy Potential) do not impose a limit on the OEPR Evaluator's professional judgment as to what other estimates (if any) to include in the OEPR. Without limiting the professional judgment of the OEPR Evaluator in estimating the Net Energy Potential and GPR Performance Metric, the following is a general description of how the Parties anticipate that the OEPR Evaluator will proceed:
1. The purpose of an OEPR is to implement the intent of the Parties as set forth in Section 1. A. (Net Energy Potential and the Intent of the Parties) of this Attachment D (Calculation and Adjustment of Net Energy Potential) by evaluating (i) whether, when the Renewable Resource Baseline (as estimated by the OEPR Evaluator on the basis of the typical meteorological year as derived from the Site's measured meteorological data) is present and the Facility is in Full Dispatch, the Facility is capable of doing what the Parties expected the Facility to do: i.e., generating and delivering to the Point of Interconnection electric energy in an amount consistent with the then applicable Net Energy Potential of the Facility (i.e., the estimate of Net Energy Potential then being used to calculate the monthly Lump Sum Payment pursuant to Section 3. (Calculation of Lump Sum Payment) of Attachment B (Company Payments for Energy, Dispatchability and Availability of BESS to the Contract); and (ii) if the Facility is not doing what the parties expected in this regard, identifying a new estimated single number with a P-Value of 95 for annual Net Energy that could be

generated and delivered by the Facility based on the estimated long-term monthly and annual total of such production over a period of the next ten years.

2. At a high level, the analysis relies on reported Actual Output (i.e., energy delivered to the Point of Interconnection) during the OEPR Period of Record to estimate Facility performance over a future evaluation period of ten years. The data from the OEPR Period of Record are first quality screened and evaluated. One-time events are assessed and removed from the record where appropriate. Values for potential energy are then calculated from the reported energy production measured at the Point of Interconnection by adjusting for 100% availability and undischarged energy. Suitable long-term reference data sets are then identified by analyzing the reference for irradiance and the normalized values for potential energy production at the Point of Interconnection over the OEPR Period of Record. Relationships between selected long-term reference irradiance data sets and normalized values for potential energy production at the Point of Interconnection are used to calculate long-term values for such on a monthly and annual basis. Finally, estimates of future Facility availability (taking into account anticipated maintenance) and losses (such as system degradation and balance of plant losses) are applied in order to calculate the Net Energy Potential. For this purpose, no reductions are made for future estimates of energy that Company may choose not to dispatch. If a copy of the IE Energy Assessment Report is available to the OEPR Evaluator, the OEPR Evaluator should review such Report before commencing preparation of the OEPR and evaluate whether it is appropriate for the OEPR Evaluator to take into account any of the work reflected in the IE Energy Assessment Report.
- F. Timeline and Fees. The terms of engagement with the OEPR Evaluator shall require the OEPR Evaluator to provide, for Party review, a draft OEPR that shall include a NEP OEPR Estimate and a Guaranteed Measured Performance Ratio Benchmark within 30 Days following the NEP Applicable Verification Date ("First OEPR"). The OEPR Evaluator shall be required to provide its completed OEPR within 30 Days following the end of the Parties' 45-Day review period under Section 2.D. (Participation of the Parties) of this Attachment D (Calculation and Adjustment of Net Energy Potential). The Parties shall each pay fifty percent (50%) of the fees and expenses charged by the OEPR Evaluator in connection with the Initial OEPR. For the Initial OEPR, the OEPR Evaluator's fees and costs must be acceptable to Company. Subscriber Organization shall pay all of the fees and expenses charged by the OEPR Evaluator in connection with any Subsequent OEPR. Subscriber Organization shall also pay for any reasonable internal fees and costs incurred by the Company as a result of its participation in the process set forth in Section 2.D. (Participation of Parties) of this Attachment D (Calculation and Adjustment of Net Energy Potential).
- G. Review of the First OEPR or and Subsequent OEPR Report. In the event Company or Subscriber Organization does not agree with the NEP OEPR Estimate or GPR Performance Metric determined by the First OEPR Evaluator, Subscriber Organization or Company may, within 30 Days of issuance of the First OEPR, engage, at its own cost, a different expert evaluator from the OEPR Consultants List (the "Second OEPR Evaluator") to prepare a second OEPR that shall include a NEP OEPR Estimate or GPR Performance Metric, as applicable ("Second OEPR"). The terms of engagement with the Second OEPR Evaluator shall require the Second OEPR Evaluator to issue the Second OEPR within 60 Days following the date of its appointment. In the event the NEP OEPR Estimates or GPR Performance Metric, as applicable, provided by the First OEPR Evaluator and the Second OEPR Evaluator are different then, within ten (10) Days of the issuance of the Second OEPR, the Parties shall, with the two evaluators, confer in an attempt to mutually agree upon a NEP OEPR Estimate or GPR Performance Metric, as applicable ("OEPR Conference").
- H. Review of the Second OEPR Evaluator Report. If the Parties are unable to agree upon an NEP OEPR Estimate or GPR Performance Metric, as applicable, within 30 Days of the OEPR Conference, then within ten (10) Days thereafter the First OEPR Evaluator and Second OEPR Evaluator shall, by mutual agreement, select a third firm from the OEPR Consultants List to act as an independent OEPR Evaluator ("Third OEPR Evaluator"). The Third OEPR Evaluator shall not be a person from the same entity as the First OEPR Evaluator or the Second OEPR Evaluator. The Parties shall direct the Third OEPR Evaluator to review the First OEPR and Second OEPR and select one as the final and binding NEP OEPR Estimate and/or GPR Performance Metric, as applicable ("Third OEPR"). The Third OEPR Evaluator shall complete its review and selection of the NEP

OEPR Estimate within thirty (30) Days following his or her retention. If the Third OEPR Evaluator selects the First OEPR, then the Party requesting the Second OEPR shall pay for the cost of the Third OEPR. If the Third OEPR Evaluator selects the Second OEPR, then the Parties shall each pay fifty percent (50%) of the fees and expenses charged by the Third OEPR Evaluator in connection with the Third OEPR.

- I. Final, Binding and Conclusive. The Parties acknowledge the inherent uncertainty in estimating the Net Energy Potential and GPR Performance Metric and hereby assume the risk of such uncertainty and waive any right to dispute any of the qualification of the person or entity appointed as the OEPR Evaluator pursuant to Section 2.A. (Selection of OEPR Evaluator) and Section 2.B. (Eligibility for Appointment as OEPR Evaluator) of this Attachment D (Calculation and Adjustment of Net Energy Potential), the appropriateness of the methodology used by OEPR Evaluator in preparing the OEPRs, the NEP OEPR Estimate and/or the GPR Performance Metric. Without limitation to the generality of the preceding sentence, the determination of the NEP OEPR Estimate and GPR Performance Metric in the First OEPR, Second OEPR (if applicable), or final decision of the Third OEPR Evaluator (if applicable) shall be final, conclusive and binding upon Company and Subscriber Organization and shall not be subject to further dispute under Section 17. (Dispute Resolution) of the Contract; provided that, nothing in this Section 2. I. (Final, Binding and Conclusive) of this Attachment D (Calculation and Adjustment of Net Energy Potential) shall preclude Subscriber Organization from engaging an OEPR Evaluator to issue a Subsequent OEPR as allowed pursuant to Section 1.F. (Subsequent OEPRs) of this Attachment D (Calculation and Adjustment of Net Energy Potential).
- J. Acceptable Persons and Entities. The OEPR Evaluator and Second OEPR Evaluator shall be selected from the following engineering firms listed below, subject to such additions or deletions effectuated by the Parties as provided in Section 2.(f) (Eligibility for Appointment as Independent AF Evaluator) of Attachment E (Monthly Reporting and Dispute Resolution by Independent AF Evaluator) to the Contract and Section 2. B. (Eligibility for Appointment as OEPR Evaluator) of this Attachment D (Calculation and Adjustment of Net Energy Potential):
- DNV GL
 - UL
 - Black & Veatch
 - Leidos Engineering

--END--

ATTACHMENT E

**MONTHLY REPORTING AND DISPUTE
RESOLUTION BY INDEPENDENT AF EVALUATOR**

1. **MONTHLY REPORT.** Commencing with the month during which the Commercial Operations Date is achieved, and for each calendar month thereafter during the Term, Subscriber Organization shall provide to Company a Monthly Report in Excel, Lotus or such other format as Company may require ("Monthly Report"), which Monthly Report shall include (i) the data for the calendar month in question populated into the form of "Monthly Report" below, (ii) the data for the BESS Measurement Period ending with the calendar month in question populated into the form of "BESS Measurement Period Report" below, and (iii) Subscriber Organization's calculations of the performance metrics and any liquidated damages assessments for the LD Period ending with such calendar month as set forth below. Subscriber Organization shall deliver such Monthly Report to Company by the tenth (10th) Business Day following the close of the calendar month in question. Subscriber Organization shall deliver the Monthly Report electronically to the address provided by the Company. Company shall have the right to verify all data set forth in the Monthly Report by inspecting measurement instruments and reviewing Facility operating records. Upon Company's request, Subscriber Organization shall promptly provide to Company any additional data and supporting documentation necessary for Company to audit and verify any matters in the Monthly Report.

PV System Monthly Report

NAME OF IPP FACILITY: [Facility Name]

MONTHLY REPORT PERIOD: [Month Day, Year] to [Month Day, Year]

Enter the information for each Force Majeure event effecting the PV System during the reporting period. Dates and times should be entered to the nearest minute. Duration and equivalent hours should be rounded to 2 decimal places. When using MWs for item (D) below, Contract Capacity is to be provided for (E); and when using number of devices for item (D), total number of devices is to be provided for (E).

Date/Time Start (A)	Date/Time End (B)	Duration (hrs) (C) = (B-A)	Size of effect in MW or Number of devices that are offline (D)	Contract Capacity or Total number of devices in the effected system (E)	Equivalent Hours (hrs) (C x D)/E
...					

Calendar hours in the reporting period: _____

Total equivalent hours for the reporting period (from above, with proper accounting for any simultaneous events): _____

Please provide the following availability information even in months containing Force Majeure even though it will not be applied in the PV System EAF Calculation.

Enter the information for each Outage during the reporting period. Dates and times should be entered to the nearest minute. Duration should be rounded to 2 decimal places.

Date/Time Start (A)	Date/Time End (B)	Duration (hrs) (B-A)
...		

Calendar hours in the reporting period: _____

Total Outage hours for the reporting period (from above): _____

Available Hours (AH) in the reporting period: _____

AH from the last eleven (11) reporting periods: _____

AH for the last twelve (12) reporting periods: _____

Enter the information for each Subscriber Organization Attributable Derating events during the reporting period. Dates and times should be entered to the nearest minute. Duration and equivalent hours should be rounded to 2 decimal places. When using MWs for item (D) below, Contract Capacity is to be provided for (E); and when using number of inverters for item (D), total number of inverters is to be provided for (E).

Date/Time Start (A)	Date/Time End (B)	Duration (hrs) (C) = (B-A)	Size of derating in MWs or Number of Inverters (D)	Contract Capacity or Total number of Inverters in the PV System (E)	Equivalent Hours (hrs) (C x D)/E
...					

Total Equivalent Subscriber Organization Attributable Derated hours (ESADH) for the reporting period: _____

ESADH from the last eleven (11) reporting periods: _____

ESADH for the last twelve (12) reporting periods: _____

Enter the information for each Planned Derating event during the reporting period. Dates and times should be entered to the nearest minute. Duration and equivalent hours should be rounded to 2 decimal places. When using MWs for item (D) below, Contract Capacity is to be provided for (E); and when using number of inverters for item (D), total number of inverters is to be provided for (E).

Date/Time Start (A)	Date/Time End (B)	Duration (hrs) (C) = (B-A)	Size of derating in MWs or Number of Inverters (D)	Contract Capacity or Total number of Inverters in the PV System (E)	Equivalent Hours (hrs) (C x D)/E
...					

Total equivalent planned derated hours (EPDH) for the reporting period: _____

EPDH from the last eleven (11) reporting periods: _____

EPDH for the last twelve (12) reporting periods: _____

Enter the information for each Unplanned Derating event during the reporting period. Dates and times should be entered to the nearest minute. Duration and equivalent hours should be rounded to 2 decimal places. When using MWs for item (D) below, Contract Capacity is to be provided for (E); and when using number of inverters for item (D), total number of inverters is to be provided for (E).

Date/Time Start (A)	Date/Time End (B)	Duration (hrs) (C) = (B-A)	Size of derating in MWs or Number of Inverters (D)	Contract Capacity or Total number of Inverters in the PV System (E)	Equivalent Hours (hrs) (C x D)/E
...					

Total equivalent unplanned derated hours (EUDH) for the reporting period: _____

EUDH for the last eleven (11) reporting periods: _____

EUDH for the last twelve (12) reporting periods: _____

Period Hours (PH) is : (8760 hours if no 29th day in February in that last twelve months otherwise 8784 hours)

Enter the Available Hours, ESADH, EPDH, and EUDH for the last twelve (12) reporting periods as calculated above and use the correct PH.

AH (A)	ESADH (B)	EPDH (C)	EUDH (D)	PV System Annual Equivalent Availability Factor $100\% \times (A - B - C - D)/PH$

If the month for which this monthly report has been prepared contains a Force Majeure event please indicate the PV System Annual Equivalent Availability Factor calculated in the previous month’s monthly report.

Enter the following properties for the facility’s PV panels that are used in the calculation of the Measured Performance Ratio. Refer to Article 2.6 for the definitions of terms.

- DC rated capacity of the system at standard test conditions ($P_{DC_{STC}}$): _____
- Temperature coefficient of power in %/°C(δ): _____
- Temperature empirical constant (a): _____
- Wind speed empirical constant (b): _____
- Conduction temperature coefficient (dT_{cond}): _____
- Annual average irradiance-weighted cell temperature ($T_{cell_typ_avg}$) _____

For the reporting period, provide the 15-minute interval averaged site data for the following measurements in .csv format (refer to Article 2.6 for the definitions of terms). The data set should include an indication of whether each interval is included or excluded in the calculation of the Measured Performance Ratio and the reason for exclusion (refer to article 2.6 for data requirements).

Measured data:

- P_{AC_i} is the apparent power output of the PV System measured at the POI averaged over time period i (MW)
- P_{DC_i} is the measured DC power output of the PV System measured at the DC input to the BESS charging system averaged over time period i (MW)
- G_{POA_i} is the measured plane of array irradiance averaged over time period i (W/m^2);
- T_{a_i} = the measured ambient temperature averaged over time period i [°C]
- WS_i = the measured wind speed corrected to a measurement height of 10 meters (using the anemometer height and proper Hellmann coefficient) averaged over time period i [m/s]

Calculated data:

- Computed cell temperature (T_{cell_i})

Using the data provided above, enter the calculated values for Measured Performance Ratio rounded to the third decimal place (0.001).

Measured Performance Ratio for the reporting period: _____

Measured Performance Ratio for this reporting period and the previous eleven (11) reporting periods: _____

Enter the Applicable Contract Year and calculated Degradation Factor for the reporting period. Refer to Article 2.6(c) for how these should be calculated.

Applicable Contract Year: _____

Degradation Factor: _____

BESS Measurement Period Report

NAME OF IPP FACILITY: [Facility Name]

BESS MEASUREMENT PERIOD: [Month Day, Year] to [Month Day, Year]

Enter the applicable information operational data collected during the most recently completed BESS Capacity Test to demonstrate satisfaction of the BESS Capacity Performance Metric during the reporting period.

Date/Time Start	Date/Time End	Total MWh delivered to the POI (A)	BESS Contract Capacity (MWh) (B)	BESS Capacity Ratio 100% x (A/B)

Enter the applicable information from operational data collected during the most recently completed BESS RTE Test to demonstrate satisfaction of the BESS Round Trip Efficiency Performance Metric during the reporting period.

Date/Time Start	Date/Time End	Total MWh delivered to the POI (A)	Charging Energy (MWh) (B)	BESS RTE Ratio 100% x (A ÷ B)

Enter the information for each Force Majeure event effecting the BESS during the reporting period. Dates and times should be entered to the nearest minute. Duration, size of reduction, maximum rated output, and equivalent hours should be rounded to 1 decimal place.

Date/Time Start (A)	Date/Time End (B)	Duration (hrs) (C) = (B-A)	Size of Reduction (MW) (D)	Maximum Rated Output (MW) (E)	Equivalent Hours (hrs) (C x D)/E
...					

Calendar hours in the reporting period: _____

Total equivalent hours for the reporting period (from above, with proper accounting for any simultaneous events): _____

Please provide the following BESS availability information even in months containing Force Majeure even though it will not be applied in the PV System EAF Calculation.

Enter the information for each BESS Outage during the reporting period. Dates and times should be entered to the nearest minute. Duration should be rounded to 1 decimal place.

Date/Time Start (A)	Date/Time End (B)	Duration (hrs) (B-A)
...		

Calendar hours in the reporting period: _____

Total Outage hours for the reporting period (from above): _____

Available Hours (AH) in the reporting period: _____

AH from the last three (3) reporting periods: _____

AH for the last four (4) reporting periods: _____

Enter the information for each BESS Planned Derating event during the reporting period. Dates and times should be entered to the nearest minute. Duration, size of reduction, maximum rated output, and equivalent hours should be rounded to 1 decimal place.

Date/Time Start (A)	Date/Time End (B)	Duration (hrs) (C) = (B-A)	Size of Reduction (MW) (D)	Maximum Rated Output (MW) (E)	Equivalent Hours (hrs) (C x D)/E
...					

Total equivalent planned derated hours (EPDH) for the reporting period: _____

EPDH from the last three (3) reporting periods: _____

EPDH for the last four (4) reporting periods: _____

Enter the information for each BESS Unplanned Derating event during the reporting period. Dates and times should be entered to the nearest minute. Duration, size of reduction, maximum rated output, and equivalent hours should be rounded to 1 decimal place.

Date/Time Start (A)	Date/Time End (B)	Duration (hrs) (C) = (B-A)	Size of Reduction (MW) (D)	Maximum Rated Output (MW) (E)	Equivalent Hours (hrs) (C x D)/E
...					

Total equivalent unplanned derated hours (EUDH) for the reporting period: _____

EUDH for the last three (3) reporting periods: _____

EUDH for the last four (4) reporting periods: _____

Period Hours (PH) is : _____ (8760 hours if no 29th day in February in that last twelve months otherwise 8784 hours)
Enter the Available Hours, EPDH and EUDH for the last four (4) reporting periods as calculated above.

AH (A)	EPDH (B)	EUDH (C)	PH (D)	BESS Annual Equivalent Availability Factor 100% x (A - B - C)/PH

Enter the information for each Unplanned (Forced) Outage during the reporting period. Dates and times should be entered to the nearest minute. Duration should be rounded to 1 decimal place.

Date/Time Start (A)	Date/Time End (B)	Duration (hrs) (B-A)
...		

Total Forced Outage Hours (FOH) for the reporting period (from above): _____

FOH from the last three (3) reporting periods: _____

FOH for the last four (4) reporting periods: _____

Enter the FOH and EUDH for the last four (4) reporting periods as calculated above.

FOH (A)	EUDH (B)	BESS Annual Equivalent Forced Outage Factor 100% x (A + B)/8760

If the BESS Measurement Period for which this report has been prepared contains a month with a BESS Force Majeure event, please indicate the proper 12-month period used to calculate the BESS Annual Equivalent Availability Factor for this report.

2. **MONTHLY REPORT DISAGREEMENTS.**

- (a) Notice of Disagreement with Monthly Report. Within ten (10) Business Days following the close of the calendar month in question, Subscriber Organization shall provide to Company the Monthly Report for such calendar month and the LD Period, the MPR Assessment Period and the BESS Measurement Period (if any) ending with such calendar month, as provided in Section 1. (Monthly Report) of this Attachment E (Monthly Reporting and Dispute Resolution by Independent AF Evaluator). Within ten (10) Business Days after Company's receipt of a Monthly Report, Company shall provide written notice to Subscriber Organization of any Monthly Report Disagreement, including with respect to the data for the calendar month covered by such Monthly Report and Subscriber Organization's calculation of, as applicable, (i) the PV System Equivalent Availability Factor for the LD Period ending with such calendar month, (ii) the MPR for the MPR Assessment Period ending with such calendar month, or (iii) any of the BESS Capacity Ratio, the RTE Ratio, the BESS Annual Equivalent Availability Factor or the BESS Equivalent Forced Outage Factor for the BESS Measurement Period (if any) ending with such calendar month ("Notice of Disagreement"). Together with any such Notice of Disagreement, the Company shall include its own calculations and other support for its position. If Company fails to provide a Notice of Disagreement within said 10-Business Day period, the Monthly Report provided by Subscriber Organization shall be deemed to be accepted by Company and shall no longer be subject to dispute by Company or Subscriber Organization.
- (b) [RESERVED]
- (c) Submission of Monthly Report Disagreement to Independent AF Evaluator. Upon issuance of a Notice of Disagreement, the Parties shall review the contents of the Monthly Report(s) together with such Notice of Disagreement and attempt to resolve such Monthly Report Disagreement. If the Parties are able to agree on a resolution of any Monthly Report Disagreement, the resulting corrected Monthly Report(s) in question shall be set forth in a writing executed by both Parties, following which (i) such corrected Monthly Reports shall no longer be subject to dispute by either Party and (ii) to the extent such resolution of such Monthly Report Disagreement affects future Monthly Reports, such future Monthly Reports shall be prepared, and the PV System Equivalent Availability Factor, the MPR, the BESS Annual Equivalent Factor and the BESS Annual Equivalent Forced Outage Factor in such future Monthly Reports shall be calculated, in a manner consistent with such resolution. If the Parties are unable to resolve such Monthly Report Disagreement within ten (10) Business Days after Company's issuance of such Notice of Monthly Report Disagreement, either Party may, within five (5) Business Days after the end of such 10-Business Day period, submit the unresolved Monthly Report Disagreement to an Independent AF Evaluator for resolution.
- (d) [RESERVED]
- (e) Appointment of Independent AF Evaluator. If either Party decides to submit an unresolved Monthly Report Disagreement to an Independent AF Evaluator, it shall provide written notice to that effect (the "Submission Notice") to the other Party, which notice shall designate which of the engineering firms on the OEPR Consultants List is to act as the Independent AF Evaluator for purposes of resolving such dispute; provided, however, for purposes of facilitating consistency in the resolution of Monthly Report Disagreements, all Monthly Report Disagreements concerning the same Performance Metric arising out of any one or more of the twelve (12) Monthly Reports issued for a given Contract Year shall be submitted to the same Independent AF Evaluator unless such Independent AF Evaluator declines to accept any such submission(s). A Submission Notice must be provided within the 5-Business Day period provided in Section 2.C. (Submission of Monthly Report Disagreement to Independent AF Evaluator) of this Attachment E (Monthly Reporting and Dispute Resolution by Independent AF Evaluator). The Parties shall each pay fifty percent (50%) of the fees and expenses charged by the Independent AF Evaluator.
- (f) Eligibility for Appointment as Independent AF Evaluator. Both Parties agree that the engineering firms listed in Section 2.J. (Acceptable Persons and Entities) of Attachment D. (Calculation and Adjustment of Net Energy Potential) are fully qualified to serve as Independent AF Evaluator. By mutual agreement between the Parties in writing, a name or names may be added to or removed from the OEPR Consultants List at any time. In no event shall there be less than three (3) names on the OEPR Consultants List.

- (g) Participation of Parties. Promptly following the issuance of a Submission Notice as provided in Section 2.E. (Appointment of Independent AF Evaluator) of this Attachment E (Monthly Reporting and Dispute Resolution by Independent AF Evaluator), Subscriber Organization and Company shall provide the Independent AF Evaluator which such data as they consider to be material to the resolution of the disputed issue(s). Subscriber Organization and Company shall also provide such additional data and information as the Independent AF Evaluator may reasonably request. The Parties shall assist the Independent AF Evaluator throughout the process of resolving such dispute, including making key personnel and records available to the Independent AF Evaluator, but neither Party shall be entitled to participate in any meetings with personnel of the other Party or review of the other Party's records. However, the Independent AF Evaluator will have the right to conduct meetings, hearing or oral arguments in which both Parties are represented.
- (h) Written Decision of Independent AF Evaluator. The terms of engagement with the Independent AF Evaluator shall require the Independent AF Evaluator to issue its written decision resolving the disputed issues submitted to it within the applicable time period set forth below, which time periods are subject to any tolling that may be applicable pursuant to Section 2.I. (Sequence to Resolving Interrelated Disagreements) of this Attachment E (Monthly Reporting and Dispute Resolution by Independent AF Evaluator): (a) 30 Days as measured from the issuance of the Submission Notice; or (b) such other time period as the Parties may agree in writing. Unless otherwise agreed by the Parties in writing:
- (i) for a Monthly Report Disagreement concerning the PV System Equivalent Availability Factor, the written decision of the Independent AF Evaluator shall set forth (aa) for the calendar month in question, the correct values for AH, EPDH, EUDH and PH to be used in calculations under Section 1. (PV System Equivalent Availability Factor Performance Metric and Liquidated Damages) of Attachment C (Required Performance Metrics; Liquidated Damages) to this Contract as determined by such Independent AF Evaluator if any such values were in dispute and (bb) for the LD Period ending with the calendar month in question, the PV System Equivalent Availability Factor for such LD Period as determined by such Independent AF Evaluator if such PV System Equivalent Availability Factor was in dispute;
 - (ii) for a Monthly Report Disagreement concerning the MPR, the written decision of the Independent AF Evaluator shall set forth (aa) the correct data points from the operational data set for the calendar month in question to be used in the calculation of MPR under Section 2.A. (Calculation of Measured Performance Ratio) of Attachment C (Required Performance Metrics; Liquidated Damages) to this Contract, for the MPR Assessment Periods that include such calendar month if any such data points were in dispute, (bb) if a MPR Test was conducted during the month in question, the correct data points from such MPR Test to be used in the calculation of MPR under Section 2.A. (Calculation of Measured Performance Ratio) of Attachment C (Required Performance Metrics; Liquidated Damages) to this Contract. for the MPR Assessment Periods that include the month preceding the month covered by the Monthly Report in question if any such data points were in dispute and (cc) for the MPR Assessment Period ending with the calendar month in question, the Measured Performance Ratio if such Measured Performance Ratio was in dispute;
 - (iii) for a Monthly Report Disagreement concerning the BESS Capacity Ratio or the RTE Ratio, the written decision of the Independent AF Evaluator shall set forth the BESS Capacity Ratio and/or the RTE Ratio for the BESS Measurement Period ending with the calendar month in question;
 - (iv) for a Monthly Report Disagreement concerning the BESS Annual Equivalent Availability Factor, the written decision of the Independent AF Evaluator shall set forth (aa) the correct values to be used for AH, EPDH, EUDH and PH under Attachment H (BESS Requirements) Section 2. (BESS Annual Equivalent Availability Factor) for the calendar month in question if any such values were in dispute and (bb) the BESS Annual Equivalent Availability Factor for the BESS Measurement Period ending with the calendar month in question if such BESS Annual Equivalent Availability Factor was in dispute; and

- (v) for a Monthly Report Disagreement concerning the BESS Annual Equivalent Forced Outage Factor, the written decision of the Independent AF Evaluator shall set forth (aa) the correct values for FOH and EUDH under Attachment H (BESS Requirements) Section 3 (BESS Annual Equivalent Forced Outage Factor) for the calendar month in question if any such values were in dispute and (bb) the BESS Annual Equivalent Forced Outage Factor for the BESS Measurement Period ending with the calendar month in question if such BESS Annual Equivalent Forced Outage Factor was in dispute.
- (i) Sequence for Resolving Interrelated Disagreements. If at the time a Monthly Report Disagreement is submitted to an Independent AF Evaluator pursuant to Section 2 (Appointment of Independent AF Evaluator) of this Attachment E (Monthly Reporting and Dispute Resolution by Independent AF Evaluator) there are one or more other unresolved Monthly Report Disagreements concerning the same Monthly Report and the same LD Period that are pending before a different Independent AF Evaluator, and the resolution of such other Monthly Report Disagreement(s) is necessary to the resolution of the Monthly Report Disagreement that has been newly submitted to a new Independent AF Evaluator as aforesaid, the time period for such new Independent AF Evaluator to issue its written decision resolving such newly submitted Monthly Report Disagreement shall be tolled until such pending Monthly Report Disagreement(s) have been resolved. For avoidance of doubt, it is the intent of the Parties that disagreements over performance ratio data and calculations for a given calendar month or a given BESS Measurement Period shall (i) not be subject to resolution twice and (ii) once resolved, shall not be reopened.
- (j) Final, Conclusive and Binding. The Parties acknowledge the inherent uncertainty in calculating the Monthly Reports, and hereby assume the risk of such uncertainty and waive any right to dispute the qualification of the person or entity appointed as the Independent AF Evaluator pursuant to Section 2E. (Appointment of Independent AF Evaluator) of this Attachment E (Monthly Reporting and Dispute Resolution by Independent AF Evaluator) and/or the appropriateness of the methodology used by Independent AF Evaluator in resolving such Monthly Report Disagreements. Without limitation to the generality of the preceding sentence, the decision of the Independent AF Evaluator as to each Monthly Report Disagreement submitted to an Independent AF Evaluator shall be final, conclusive and binding upon Company and Subscriber Organization and shall not be subject to further dispute under Section 17. (Dispute Resolution) of the Contract.

3. PERIODIC REVIEW OF METHOD OF CALCULATING AND REPORTING MONTHLY REPORT.

At least once per Contract Year, Company shall review the method of calculating and reporting Monthly Report under this Contract to determine if other variables should be incorporated into such calculations. Any revisions to the Monthly Report calculations in this Contract shall be mutually agreed to by both Subscriber Organization and Company.

4. FUTURE CHANGES IN REPORTING REQUIREMENTS. Subscriber Organization shall reasonably cooperate with any Company requested revisions to the Monthly Report to include additional data that may be necessary from time to time to enable Company to comply with any new reporting requirements directed by the PUC or otherwise imposed under applicable Laws.

--END--

ATTACHMENT F
FACILITY OWNED BY SUBSCRIBER ORGANIZATION

1. THE FACILITY.

- (a) Drawings, Diagrams, Lists, Settings and As-Built.
- (i) Single-Line Drawing, Interface Block Diagram, Relay List, Relay Settings and Trip Scheme. A preliminary single-line drawing (including notes), Interface Block Diagram, relay list, relay settings, and trip scheme of the Facility shall, after Subscriber Organization has obtained prior written consent from Company, be attached to this Contract on the Execution Date as Exhibit F-5 (Single-Line Drawing and Interface Block Diagram) and Exhibit F-6 (Relay List and Trip Scheme). A final single-line drawing (including notes), Interface Block Diagram, relay list and trip scheme of the Facility shall, after having obtained prior written consent from Company, be labeled the "Final" Single-Line Drawing, the "Final" Interface Block Diagram and the "Final" Relay List and Trip Scheme and shall supersede Exhibit F-5 (Single-Line Drawing and Interface Block Diagram) and Exhibit F-6 (Relay List and Trip Scheme) to this Contract and shall be made a part hereof on the Commercial Operations Date. After the Commercial Operations Date, no changes shall be made to the "Final" Single-Line Drawing, the "Final" Interface Block Diagram and the "Final" Relay List and Trip Scheme without the prior written consent of Subscriber Organization and Company. The single-line drawing shall expressly identify the Point of Interconnection of Facility to Company System.
 - (ii) As-Built. Subscriber Organization shall provide final as-built drawings of the Subscriber Organization-Owned Interconnection Facilities within 30 Days of the successful completion of the Acceptance Test.
 - (iii) Modeling. Subscriber Organization shall provide the models as set forth in Exhibit F-4.
 - (iv) No Material Changes. Subscriber Organization agrees that no material changes or additions to the Facility as reflected in the "Final" Single-Line Drawing (including notes), the "Final" Interface Block Diagram and the "Final" Relay List and Trip Scheme, shall be made without Subscriber Organization first having obtained prior written consent from Company. The foregoing are subject to changes and additions as part of any Performance Standards Modifications. If Company directs any changes in or additions to the Facility, records and operating procedures that are not part of any Performance Standards Modifications, Company shall specify such changes or additions to Subscriber Organization in writing, and, except in the case of an emergency, Subscriber Organization shall have the opportunity to review and comment upon any such changes or additions in advance.
- (b) Certain Specifications for the Facility.
- (i) Subscriber Organization shall furnish, install, operate and maintain the Facility including breakers, relays, switches, synchronizing equipment, monitoring equipment and control and protective devices approved by Company as suitable for parallel operation of the Facility with Company System. The Facility shall be accessible at all times to authorized Company personnel.
 - (ii) The Facility shall include:

[LIST OF THE FACILITY

Examples may include, but are not limited to:

- **Subscriber Organization-Owned Interconnection Facilities**
- **Substation**
- **Control and monitoring facilities**
- **Transformers**
- **Generating and BESS equipment (as described in Exhibit F-1)**
- **"Lockable" cabinets or housings suitable for the installation of the Company-Owned Interconnection Facilities located on the Site**
- **Relays and other protective devices**
- **Leased telephone line and/or equipment to facilitate microwave communication]**

(iii) The Facility shall comply with the following **[includes excerpts of language that may be requested by Company following Completion of IRS]**:

- A. Subscriber Organization shall install a ____ kV gang operated, load breaking, lockable disconnect switch and all other items for its switching station (relaying, control power transformers, high voltage circuit breaker). Bus connection shall be made to a manually and automatically (via protective relays) operated high-voltage circuit breaker. The high-voltage circuit breaker shall be fitted with bushing style current transformers for metering and relaying. Downstream of the high-voltage circuit breaker, a structure shall be provided for metering transformers. From the high-voltage circuit breaker, another bus connection shall be made to another pole mounted disconnect switch, with surge protection.
- B. Subscriber Organization shall provide within the Subscriber Organization-Owned Interconnection Facilities a separate, fenced area with separate access for Company. Subscriber Organization shall provide all conduits, structures and accessories necessary for Company to install the Revenue Metering Package. Subscriber Organization shall also provide within such area, space for Company to install its communications, supervisory control and data acquisition ("SCADA") equipment (remote terminal unit or equivalent) and certain relaying if necessary for the interconnection. Subscriber Organization shall also provide AC and DC source lines as specified by Company. Subscriber Organization shall provide a telephone line for Company-owned meters. Subscriber Organization shall work with Company to determine an acceptable location and size of the fenced-in area. Subscriber Organization shall provide an acceptable demarcation cabinet on its side of the fence where Subscriber Organization and Company wiring will connect/interface.
- C. Subscriber Organization shall ensure that the Subscriber Organization-Owned Interconnection Facilities have a lockable cabinet for switching station relaying equipment. Subscriber Organization shall select and install relaying equipment acceptable to Company. At a minimum, the relaying equipment will provide over and under frequency (81) negative phase sequence (46), under voltage (27), over voltage (59), ground over voltage (59G), over current functions (50/51) and direct transfer trip (if required). The settings shall be consistent with the requirements for over/under frequency and voltage ride-through. Subscriber Organization shall install protective relays that operate a lockout relay (86), which in turn will trip the main circuit breaker and not allow it to be reclosed without reset.

- D. [RESERVED]
- E. Subscriber Organization's equipment also shall provide at a minimum:
- (i) Interface with Company's Telemetry and Control, or designated communications and control interface, to provide telemetry of electrical quantities such as total Facility net MW, MVar, power factor, voltages, currents, and other quantities as identified by the Company;
 - (ii) Interface with Company's Telemetry and Control, or designated communications and control interface, to provide status for circuit breakers, reactive devices, switches, and other equipment as identified by the Company;
 - (iii) Interface with Company's Telemetry and Control, or designated communications and control interface, to provide control to incrementally raise and lower the voltage target at the point of regulation operating in automatic voltage regulation control;
 - (iv) Interface with Company's Telemetry and Control, or designated communications and control interface, to provide the active power control requirements of this Contract. More than one interface may be required if Facility energy components, such as a BESS and variable generation resource are controlled separately by the Company (as in grid-charging BESS);
 - (v) Interface with Company's Telemetry and Control, or designated communications and control interface, for the Company to specify control system modes of operation and parameters, for remotely configurable parameters and operating states required under this Contract;
 - (vi) For Variable Energy Facilities: Interface with Company's Telemetry and Control, or designated communications and control interface, to provide telemetry of equipment availability and meteorological and production data required under Section 8 (Data and Forecasting) of this Attachment F (Facility Owned by Subscriber Organization) and the Facility's Power Possible.
 - (vii) Provision for Loss of Telemetry and Control: If Company's Telemetry and Control, or designated communications and control interface, is unavailable, due to loss of communication link, Telemetry and Control failure, or other event resulting in loss of the remote control by Company, provision must be made for Subscriber Organization to be able to institute via local controls, within 5 minutes (or such other period as Company accepts in writing) of the verbal directive by the Company System Operator, such change in voltage regulation target and real power export or import as directed by the Company System Operator.
- F. If Subscriber Organization adds, deletes and/or changes any of its equipment, or changes its design in a manner that would change the characteristics of the equipment and specifications used in the IRS, Subscriber Organization shall be required to obtain Company's prior written approval. If an analysis to revise parts of the IRS is required, Subscriber Organization shall be responsible for the cost of revising those parts of the IRS, and modifying and paying for the cost of the modifications to the Facility and/or the Company-Owned Interconnection Facilities based on the revisions to the IRS.

G. Cybersecurity and Critical Infrastructure Protection.

[DRAFTING NOTE: COMPANY RETAINS SOLE DISCRETION TO CONSIDER THE LESS STRINGENT REQUIREMENTS (WHICH ARE INCLUDED IN THE FIRST SET OF ALTERNATIVE CYBER-SECURITY PROVISIONS UNDER G. (i) THROUGH (iv)) FOR PROJECTS THAT DO NOT EXCEED 1 MW.]

- (i) Safety and Security Procedures. The Subscriber Organization shall maintain and enforce safety and security procedures to safeguard: all data provided by Company to Subscriber Organization pursuant to this Contract or in any way connected with the CBRE Program and the administration of the CBRE Program including but not limited to Subscriber names, Subscriber account numbers and information on such accounts, Subscriber addresses, Subscriber rate schedules and Subscriber CBRE bill credit information (“Company CBRE Data”); and all information regarding Company’s customers, customer lists, any of the data and testing results produced under this Contract and any information identified by Company as confidential (“Company Customer Data” and together with Company CBRE Data, collectively referred to as “Company Confidential Information”); all generation and telemetry data provided by the Subscriber Organization to the Company (“SO Data”); in Subscriber Organization’s possession, including Company Confidential Information that Subscriber Organization provides to any contractors, consultants, and other third parties retained by Subscriber Organization to assist Subscriber Organization to perform under this Contract in the course of Subscriber Organization’s performance pursuant to this Contract. Subscriber Organization warrants that it shall (A) use the National Institute of Standards and Technology (“NIST”) industry best practices for physical and systems security measures to prevent destruction, loss, alteration or unauthorized access to, use of, or tampering with, the CBRE Facility, Subscriber Organization software, and Company Confidential Information, including to protect the confidentiality and integrity of any of Company Confidential Information, operation of Company’s systems, and to prevent viruses and similar destructive code from being placed in any software or data provided to Company, on Subscriber Organization’s or Company’s website, or in Subscriber Organization’s or Company’s programming; and (B) use NIST industry best practices physical security and precautionary measures to prevent unauthorized access or damage to the CBRE Facility, including to protect the confidentiality and integrity of any of Company’s Confidential Information as well as the operation of Company’s systems. Subscriber Organization shall, at a minimum, protect Company’s Confidential Information and provide the standard of care required by NIST cybersecurity requirements, and the same measures it uses to protect its own confidential information.
- (ii) Exception to Certain NIST Requirements. Company, at its sole and absolute discretion, may waive the requirements concerning NIST industry best practices as set forth in subsection (i)(A) and (B) above provided that Subscriber Organization implements alternate measures that Company deems acceptable and not inconsistent with Company’s standards with respect to (A) physical and systems security measures to prevent destruction, loss, alteration or unauthorized access to, use of, or tampering with, the CBRE Facility, software and Company’s Confidential Information, including to protect the confidentiality and integrity of any of Company’s Confidential Information, operation of Company’s systems, and to prevent viruses and similar destructive code from being placed in any software provided to Company, on Subscriber

Organization's or Company's website, or in Subscriber Organization's or Company's programming; and (B) physical security and precautionary measures to prevent unauthorized access or damage to the CBRE Facility, including to protect the confidentiality and integrity of any of Company's Confidential Information as well as the operation of Company's systems.

(iii) Security Breach. In the event that Subscriber Organization discovers or is notified of a breach, potential breach of security, or security incident at the CBRE Facility or of Subscriber Organization's systems (a "Security Breach"), Subscriber Organization shall immediately (i) notify Company of such Security Breach, whether or not such breach has compromised any of Company Confidential information, (ii) investigate and remediate the effects of the Security Breach, (iii) cooperate with Company with respect to any such Security Breach and provide necessary information on the Security Breach as requested by Company; and (iv) comply with all applicable privacy and data protection laws, including any notification obligations. Any remediation of any Security Breach will be at Subscriber Organization's sole expense.

(iv) "Subscriber" means a retail customer of the Company who owns a subscription of Subscriber Organization's CBRE project interconnected with the Company.

**[ALTERNATIVE ENHANCED CYBER-SECURITY PROVISIONS-
WAIVED SOLELY AT DISCRETION OF COMPANY.]**

- (i) Security Policies and Documentation. Subscriber Organization shall implement and document security policies and standards in accordance with industry best practices (e.g., aligned with the intent of NERC CIP-003-6 R2) and consistent with Company's security policies and standards. Subscriber Organization shall submit documentation describing the approach, methodology, and design to provide physical and cyber security (i.e., aligned with the intent of NERC CIP-003-6 R2) with its submittal of the design drawings pursuant to Section 1(c) (Design Drawings, Bill of Materials, Relay Settings and Fuse Selection) of Attachment F (Facility Owned by Subscriber Organization) which shall be at least sixty (60) Days prior to the Acceptance Test.
- The design shall meet industry standards and best practices, consistent with the National Institute of Standards and Technology ("NIST") guidelines as indicated in Special Publication 800-53 Rev. 4 "Security and Privacy Controls for Federal Information Systems and Organizations" and Special Publication 800-82 Rev. 2 "Guide to Industrial Control Systems (ICS) Security". The system shall be designed with the criteria to meet applicable compliance requirements and identify areas that are not consistent with NIST guidelines and recommendations.
 - The cybersecurity documentation shall include a block diagram of the control system with all external connections clearly described.
 - Subscriber Organization shall provide such additional information as Company may reasonably request as part of a security posture assessment.
 - Company shall be notified in advance when there is any condition that would compromise physical or cyber security.

- Subscriber Organization shall, at the request of Company or, in the absence of any request from Company, at least annually, provide Company with updated documentation and diagrams including a record of changes.
- (ii) Network and Application Security. Subscriber Organization shall implement appropriate network and application security processes and practices commensurate with the level of risk as determined by periodic risk assessments (i.e., aligned with the intent of NERC CIP-005-5):
- Segment and segregate networks and functions, including physical and logical separation between business networks and control system networks (i.e., aligned with the intent of NERC CIP-005-5 R1).
 - Limit unnecessary lateral communications (i.e., aligned with the intent of NERC CIP-005-5 R1).
 - Harden network devices (i.e., aligned with the intent of NERC CIP-007-6 R1).
 - Secure access to infrastructure devices (i.e., aligned with the intent of NERC CIP-004-6 R4).
 - Perform out-of-band (OoB) network management (i.e., aligned with the intent of NERC CIP-005-5 R2).
 - Validate integrity of hardware and software (i.e., aligned with the intent of NERC CIP-010-3 R1 and NERC CIP-006-6 R1 Part 10).
- (iii) Endpoint and Server Security. Subscriber Organization shall implement appropriate endpoint and server security processes and practices commensurate with the level of risk as determined by periodic risk assessments:
- Mechanisms to identify vulnerabilities and apply security patches in a timely manner (i.e., aligned with the intent of NERC CIP-007-6 R2).
 - Malware defense and anti-phishing capabilities (i.e., aligned with the intent of NERC CIP-007-6 R3).
 - Access Controls to enforce the least privilege principle and provide access to resources only for authorized users (i.e., aligned with the intent of NERC CIP-004-6 R4).
 - Secure authentication mechanisms including multi-factor authentication for systems with higher risk exposure (i.e., aligned with the intent of NERC CIP-007-6 R5 and NERC CIP-005-5 R2).
 - Data confidentiality, protection, and encryption technologies for endpoints, servers, and mobile devices (i.e., aligned with the intent of NERC CIP-011-2 R1 and NERC CIP-005-5 R2).

Subscriber Organization shall (consistent with the following sentence) ensure that no malicious software ("Malware") or unauthorized code is introduced into any aspect of the Facility, Interconnection Facilities, the

Company Systems interfacing with the Facility and Interconnection Facilities, and any of Subscriber Organization's critical control systems or processes used by Subscriber Organization to provide energy, including the information, data and other materials delivered by or on behalf of Subscriber Organization to Company, (collectively, the "Environment"). Subscriber Organization shall periodically review, analyze and implement improvements to and upgrades of its Malware prevention and detection programs and processes that are commercially reasonable and consistent with the then current technology industry's standards and, in any case, not less robust than the programs and processes implemented by Subscriber Organization with respect to its own information systems.

- (iv) Cybersecurity Program. Subscriber Organization shall establish and maintain a continuous cybersecurity program (i.e., aligned with the intent of NERC CIP-003-6) that enables the Subscriber Organization (or its designated third party) to:
 - (aa) Define the scope and boundaries, policies, and organizational structure of the cybersecurity program.
 - (bb) Conduct periodic risk assessments to identify the specific threats to and vulnerabilities of the Subscriber Organization's Organization consistent with guidance provided in NIST Special Publication 800-30 Rev. 1 "Guide for Conducting Risk Assessments".
 - (cc) Implement appropriate mitigating controls and training programs and manage resources.
 - (dd) Monitor and periodically test the cybersecurity program to ensure its effectiveness. Subscriber Organization shall review and adjust their cybersecurity program as appropriate for any assessed risks.
 - (ee) Applicability is extended to Cloud Service providers and other third-party services the Subscriber Organization may use.
- (v) Security Monitoring and Incident Response. Company and Subscriber Organization shall collaborate on security monitoring and incident response, define points of contact on both sides, establish monitoring and response procedures, set escalation thresholds, and conduct training (i.e., aligned with the intent of NERC CIP-008-5). Subscriber Organization shall, at the request of Company or, in the absence of any request from Company, at least quarterly, provide Company with a report of the incidents that it has identified and describe measures taken to resolve or mitigate.

In the event that Subscriber Organization discovers or is notified of a breach, potential breach of security, or security incident at Subscriber Organization's Facility or of Subscriber Organization's systems, Subscriber Organization shall immediately (aa) notify Company of such potential, suspected or actual security breach, whether or not such breach has compromised any of Company's confidential information; (bb) investigate and promptly remediate the effects of the breach, whether or not the breach was caused by Subscriber Organization; (cc) cooperate with Company with respect to any such breach or unauthorized access or use; (dd) comply with all applicable privacy and data protection laws governing Company's or any other individual's or entity's data; and (ee) to the extent such breach was caused by Subscriber

Organization, provide Company with reasonable assurances satisfactory to Company that such breach, potential breach, or security incident shall not recur. Subscriber Organization shall provide documentation to Company evidencing the length and impact of the breach. Any remediation of any such breach will be at Subscriber Organization's sole expense.

If malicious software or unauthorized code is found to have been introduced into the Environment, Subscriber Organization will promptly notify Company. Subscriber Organization shall take immediate action to eliminate and remediate the effects of the Malware, at Subscriber Organization's expense. Subscriber Organization shall not modify or otherwise take corrective action with respect to the Company Systems except at Company's request. Subscriber Organization shall promptly report to Company the nature and status of all efforts to isolate and eliminate malicious software or unauthorized code.

- (vi) Monitoring and Audit. Subscriber Organization shall provide information on available audit logs and reports relating to cyber and physical and security (i.e., aligned with the intent of NERC CIP-007-6 R4). Company may audit Subscriber Organization's records to ensure Subscriber Organization's compliance with the terms of this Section 1(b) (iii) G (Cybersecurity and Critical Infrastructure Protection) of this Attachment F (Facility Owned by Subscriber Organization), provided that Company has provided reasonable notice to Subscriber Organization and any such records of Subscriber Organization's will be treated by Company as confidential.
- (vii) Contingency Plans. Subscriber Organization shall implement and maintain a business continuity plan, a disaster recovery plan, and an incident response plan ("Contingency Plans" – i.e., aligned with the intent of NERC CIP-009-6) appropriate for the level of risk associated with the Work under this Contract. The Contingency Plans shall be provided to Company upon request. Such Contingency Plans shall be updated to reflect lessons learned from real recovery events.

H. Available Power Production.

- (i) Variable Energy Systems. Subscriber Organization's available power production considering equipment and resource availability (Power Possible) will be determined at any given time using the best-available data and methods for an accurate representation of the amount of active power at the Point of Interconnection.
- (ii) Variable Energy Systems Paired with Storage Operated through a Single Active Power Control Interface. For variable energy systems paired with storage operated through a single active power control interface (i.e., charging indirectly controlled through dispatch), Subscriber Organization's available power production considering equipment and resource availability and state of charge of the storage (Power Possible) will be determined at any given time using the best-available data and methods for an accurate representation of the amount of active power at the Point of Interconnection. Telemetry will be provided to indicate state of charge, including available estimated duration at the current dispatch given state of charge and forecast production.
- (iii) Storage Directly Controlled by the Company. Subscriber Organization's available power production considering state of charge (Power Possible) will be

supplied as an accurate representation of the amount of maximum and minimum (negative) available active power at the Point of Interconnection and the duration available at the current dispatch. If the Facility allows for allocation of capacity to different modes of operation (i.e., reservation of capacity for regulation or contingency response), then the available capacity in each allocated region shall be reported individually and controlled separately through separately designated dispatch or active power control interface.

- I. For variable resources where Power Possible is derived, in part or in whole, from a measured available variable energy source such as solar or wind: To the extent available, the Parties shall use Subscriber Organization's real time Power Possible communicated to Company through the SCADA System except to the extent that the Potential Energy does not accurately reflect the actual available active power at the Point of Interconnection (plus or minus 0.1 MW). During those periods of time when the SCADA derived Power Possible is unavailable or does not accurately represent the available power production considering equipment and resource availability, the Parties shall use the best available data obtained through commercially reasonable methods to determine the Power Possible. Follow up actions to resolve the discrepancy will be as provided in Section 1(j) (Demonstration of Facility) of this Attachment F (Facility Owned by Subscriber Organization).
 - J. Subscriber Organization shall reserve space within the Site for possible future installation of Company-owned meteorological equipment (such as wind speed, direction and relative humidity monitors, SODAR and irradiance monitors) and AC and DC source lines for such equipment as may be required depending on the Facility resource type and location. In the event Company decides to install such meteorological equipment: (i) Subscriber Organization shall work with Company to determine an acceptable location for such equipment and any associated wiring, interface or other components; and (ii) Company shall pay for the needed equipment, and installation of such equipment, unless otherwise agreed to by the Parties. Company and Subscriber Organization shall use commercially reasonable efforts to facilitate installation and minimize interference with the operation of the Facility.
 - K. The Facility shall, at a minimum, satisfy the wind load and seismic load requirements of the International Building Code and any more stringent requirements imposed under applicable Laws.
- (c) Design Drawings, Bill of Material, Relay Settings and Fuse Selection. Subscriber Organization shall provide to Company for its review the design drawings, Bill of Material, relay settings and fuse selection for the Facility, and Company shall have the right, but not the obligation, to specify the type of electrical equipment, the interconnection wiring, the type of protective relaying equipment, including, but not limited to, the control circuits connected to it and the disconnecting devices, and the settings that affect the reliability and safety of operation of Company's and Subscriber Organization's interconnected system. Subscriber Organization shall provide the relay settings and protection coordination study, including fuse selection and AC/DC Schematic Trip Scheme (part of design drawings), for the Facility to Company during the 60% design. Company, at its option, may, with reasonable frequency, witness Subscriber Organization's operation of control, synchronizing, and protection schemes and shall have the right to periodically re-specify the settings. Subscriber Organization shall utilize relay settings prescribed by Company, which may be changed over time as Company System requirements change.
- (d) Disconnect Device. Subscriber Organization shall provide a manually operated disconnect device which provides a visible break to separate Facility from Company System. Such disconnect device shall be lockable in the OPEN position and be readily accessible to Company personnel at all times.

- (e) Other Equipment. Subscriber Organization shall install, own and maintain the infrastructure associated with the Revenue Metering Package, including but not limited to all enclosures (meter cabinets, meter pedestals, meter sockets, pull boxes, and junction boxes, along with their grounding/bonding connections), CT/PT mounting structures, conduits and duct lines, enclosure support structures, ground buses, pads, test switches, terminal blocks, isolation relays, telephone surge suppressors, and analog phone lines (one per meter), subject to Company's review and approval.
- (f) Maintenance Plan. Subscriber Organization shall maintain Subscriber Organization-Owned Interconnection Facilities in accordance with Good Engineering and Operating Practices.
- (g) Active Power Control Interface. **[COMPANY TO REVISE THIS SECTION BASED ON SPECIFICS OF THE PROJECT.]**

- (i) Subscriber Organization shall provide and maintain in good working order all equipment, computers and software associated with the control system (the "Active Power Control Interface") necessary to interface the Facility active power controls with the Company System Operations Control Center for real power control of the Facility by the Company System Operator.

The detailed design will be tailored to the specific resource type and configuration to achieve the functional requirements of the Facility.

The Active Power Control Interface will be used to control the net real power export (or import, as applicable) from the Facility for load following, system balancing, energy arbitrage, and/or supplemental frequency control as required under this Attachment F (Facility Owned by Subscriber Organization).

For variable resources paired with storage: The implementation of the Active Power Control Interface will allow the Company System Operator to control the net real power export (or import, as applicable) from the entire Facility, up to Power Possible, remotely from the Company System Operations Control Center through control signals from the Company System Operations Control Center. The Facility will maintain the power level specified by the Company through the variable resource and BESS available energy, subject to the availability of resource and BESS State of Charge.

For facilities with grid charging storage, the Active Power Control interface may also direct the charging/discharging of energy from the BESS.

The Facility real power output (or import, if storage charging is enabled) will automatically adjust to a change in frequency in accordance with the frequency response requirements provided in this Attachment F (Facility Owned by Subscriber Organization).

- (ii) Company shall review and provide prior written approval of the design for the Active Power Control Interface to ensure compatibility with Company's centralized control systems and use of Facility available energy and storage capabilities. To ensure such continued compatibility, Subscriber Organization shall not materially change the approved design without Company's prior review and written approval. This will include design description and parameters for the Subscriber Organization's control system(s), which determine provision of net real power from the variable resource System (i.e., wind or WTG) and/or the BESS storage, and charging of the BESS storage, in response to the Active Power Control signal or signals.
- (iii) The Active Power Control Interface shall include, but not be limited to, a demarcation cabinet, ancillary equipment and software necessary for Subscriber Organization to connect to Company's Telemetry and Control, located in Company's portion of the Facility switching station which shall provide the control signals to the Facility and send feedback status to the Company System Operations Control Center. The control type shall be analog output (set point) or raise/lower controls and will be established by the Company prior to final design approval.

- (iv) The Active Power Control Interface shall also include provision for feedback points from the Facility indicating when active power target in MW for the Active Power Control signal(s). The Facility shall provide the MW target feedback to the Company SCADA system immediately upon receiving the respective control signal from the Company.
- (v) Subscriber Organization shall provide to the telemetry interface analogs for the gross production of the energy resource(s) at the Facility (for example, DC or AC MW production of the variable resource generator(s), depending on design; gross DC MW of the BESS, etc.). Subscriber Organization shall also provide the total net AC MW production at the Point of Interconnection.
- (vi) The Active Power Control Interface shall provide for remote control of the real power output of the Facility by the Company at all times. If the Active Power Control Interface is unavailable or disabled, the Facility may not export electric energy to Company and the Facility shall be deemed to be in Subscriber Organization-Attributable Non-Generation status, unless the Company, in its sole discretion, agrees on an alternate means of dispatch. If Subscriber Organization fails to provide such remote control capability (whether temporarily or throughout the Term), then, notwithstanding any other provision of this Attachment F (Facility Owned by Subscriber Organization), Company shall have the right to derate or disconnect the entire Facility during those periods that such control capability is not provided and the Facility shall be deemed to be in Subscriber Organization-Attributable Non-Generation status for such periods.
- (vii) The rate at which the Facility changes net real power in response to the active power control shall not be less than the greater of 2 MW per minute or 10% of the Facility capacity per minute, and shall make available through agreed parameters, such faster ramp as the installed equipment can support. The Facility's Active Power Control Interface will be used by Company to control the rate at which electric energy is changed to achieve the active power limit for load-following and regulation. The Facility will respond to the active power control request immediately with an echo of the set point and measurable change within the 4 second control cycle.
- (viii) The Facility shall accept the following controls related to active power and frequency response to or from the Company centralized control system:
 - Power Reference Setpoint from Company (based on the input to the Facility, from the Active Power Control Interface): The Facility output shall match this setting from the Variable Resource and/or BESS so long as it can be supported by the variable resource and/or BESS State of Charge (Power Possible does not change). This net output should be accurate within +/- 0.1 MW under normal frequency conditions. This setpoint will be modified as appropriate in the controls by the appropriate frequency response consistent with Section 1(g)(xi) (Active Power – Frequency Response (DROOP)), Section 1(g)(xii) (Dynamic Active Power – Frequency Performance), and **[FOR FACILITIES WITH STORAGE]** Section 1(g)(xiii) (Alternate Active Power / Frequency Response Modes) of this Attachment F (Facility Owned by Subscriber Organization).
 - For variable energy resources: The Facility shall include Variable Resource Enable/Disable control. When "Disable" is selected, the Facility shall ramp down, shutdown, and leave offline variable resource generators. When "Enable" is selected, the Facility variable resource generators can start up, ramp up, and remain in normal operations subject to Company active power dispatch.
 - **From Company:** Frequency Response Mode (DROOP, isochronous) state (where alternate modes of operation are required).
 - **From Subscriber Organization:**
 - Power Possible (Available maximum capacity): See above, instantaneous limit for available energy, represents max level the Facility can produce under present resource, BESS State of

Charge (if applicable) and equipment conditions. This is used as upper limit for Company Dispatch.

- For variable energy resources, maximum level the variable generation resources can produce under present variable resource and equipment conditions.
- Minimum Sustained Limit: Minimum output level the Facility can be reduced to continuously without delay (ecomn). For projects with BESS: If BESS charging from the grid is permitted, and charging capacity is available, this will be a negative value.
- Minimum Transient Limit (for frequency response, regulation) (lfcmn). For projects with BESS: If BESS charging from the grid is permitted, and charging capacity is available, this will be a negative value.
- Maximum Dispatchable Ramp Rate: Controlled ramp rate available for controlled changes in output.
- For projects with a BESS, Subscriber Organization shall also provide the following:
 - BESS potential (BESS State of Charge and projected number of hours at present dispatch, minimum dispatch, and maximum dispatch).
 - Frequency Response Mode (DROOP, isochronous) state.
- (ix) Subscriber Organization shall not override Company's active power controls without first obtaining specific approval to do so from the Company System Operator unless there is a system emergency. Disabling of the remote Active Power Control shall initiate telemetry notification to the Company.
- (x) The requirements of the Active Power Control Interface may be modified as mutually agreed upon in writing by the Parties.

Active Power Communications between Company and Subscriber Organization. Company will receive and send AGC Set-Point and related data through the communications interface in accordance with Company standards. The data points covered under this Contract, as described below, may overlap with data requirements described elsewhere.

AGC Data Points to be sent from Subscriber Organization to Company via SCADA. The following data points will be transmitted via SCADA from Subscriber Organization to Company and represent Facility level data [Note: **May be modified based on resource type and Facility requirements**]:

DESCRIPTION	UNITS
AGC Set-Point (echo)	MW
Power demand	MW
Actual power	MW
Power Possible	MW
Actual reactive power	Mvars
Average Voltage	Kv
Variable Generation potential	MW
[Wind only] Number of turbines online and running	Integer
BESS State of Charge	Pct
[PV only] Inverters online	Integer
Facility duration at current output	HRS
AGC Status	Remote/Local
[For facilities with alternate modes of frequency response] Indication of Frequency Response Mode	Integer Droop, ISOCH

Response times and limitations of Facility in regard to Active Power Control

The following protocols outline the expectations for responding to the AGC Set-Point.

Frequency of Changes. Company may send a new AGC Set-Point to the Facility at up to the AGC control cycle (present 4 seconds).

Range of AGC Set-Point. The range of set point values can be between 0% and 100% of Power Possible. For projects offering grid-charging storage, negative set-point values may be required.

Backup Communications

In the event of an AGC failure, Company and Subscriber Organization shall communicate via telephone, or other method mutually agreeable between the Parties, in order to correct the failure.

(xi) Active Power - Frequency Response (DROOP).

The Facility shall provide a primary frequency response with a frequency droop characteristic reacting to system frequency at the Point of Interconnection in both the overfrequency and underfrequency directions except as limited by the minimum and maximum available capacity and energy potential at the time of the event including BESS state of charge. This response must be timely and sustained rather than injected for a short period and then withdrawn. For over-frequency events, response may include absorption through charging (as applicable under the terms of this Contract). Subscriber Organization shall provide minimum operational limits for each online resource and the Facility for primary frequency response.

Frequency will be calculated over a period of time (e.g., three to six cycles, or other period as specified by Company), and filtered to take control action on the fundamental frequency component of the calculated signal. Calculated frequency may not be susceptible to spikes caused by phase jumps on the Company system.

The active power-frequency control system, and overall response of the inverter-based resource (plant), must meet the following performance aspects (see figure below):

The active power-frequency control system shall have an adjustable proportional droop characteristic with a default value of [4%] percent. The droop setting shall permit a setting from 0.1% to 10%. This setting shall be changed upon Company's written request as necessary for grid droop response coordination. The droop setting shall be tunable and may be specified during commissioning. The droop shall be a permanent value based on Pmax (maximum nominal active power output of the plant) and Pmin (typically 0 for an inverter-based resource). This keeps the proportional droop constant across the full range of operation. The curve for an inverter-based BESS may include the negative active power quadrant of this curve. The droop response must include the capability to respond in both the upward (underfrequency) and downward (overfrequency) directions. Frequency droop will be based on the difference between maximum nameplate active power output (Pmax) and zero output (Pmin) such that the [4%] percent droop line is always constant for a resource.

Subscriber Organization shall make commercially reasonable efforts to provide frequency response without a deadband, but in any case, not to exceed +/- 0.0166 Hz. If the active power-frequency control system has a deadband, it shall be a nonstep deadband that is adjustable between 0 Hz and the full frequency range of the droop characteristic with a default value not to exceed ± 0.036 Hz. (Nonstep deadband is where the change in active power output starts

from zero deviation on either side of the deadband.) (Frequency deadband is the range of frequencies in which the unit does not change active power output.)

Inverter-based resources may consider a small hysteresis characteristic where linear droop meets any deadband to reduce dithering of inverter output when operating near the edges of the deadband. The hysteresis range may not exceed ± 0.005 Hz on either side of the deadband. If measurement resolution is not sufficient to measure this frequency, hysteresis may not be used.

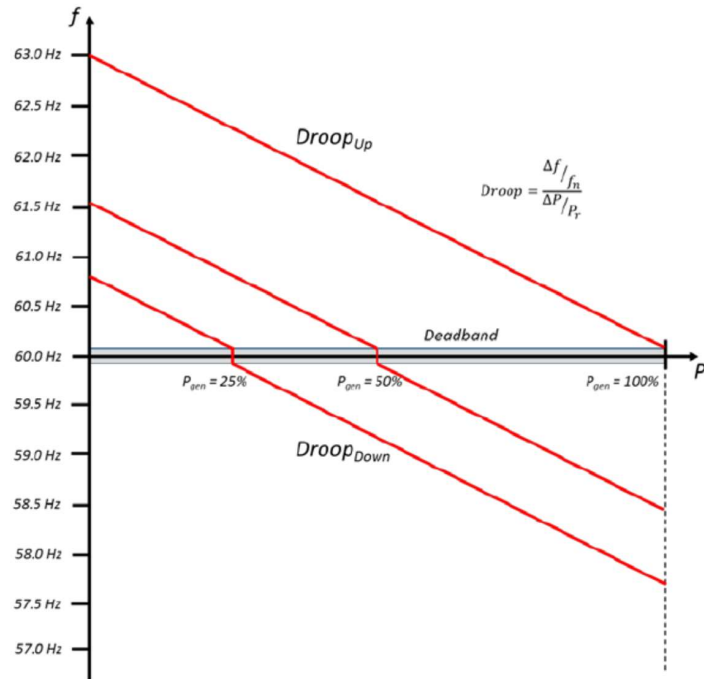

Active Power - Frequency Control Characteristic

Nominal System Frequency is 60.00 Hz.

The closed-loop dynamic response of the active power-frequency control system of the overall inverter-based resources, as measured at the POI must have the capability to meet or exceed the performance specified in below. Subscriber Organization shall ensure that the models and parameters for the resources and control equipment are consistent with those provided during the IRS process and that any updates have been provided to the Company reflecting currently implemented settings and configuration.

(xii) Dynamic Active Power-Frequency Performance.

For a step change in frequency at the point of measure of the inverter-based resource [NOTE - MAY BE ADJUSTED AS THE RESULT OF IRS]:

Reaction time: The time between a step change in frequency and the time when the resource active power output begins responding to the change shall be less than 500 ms or as otherwise specified by Company.¹

¹ Time between step change in frequency and the time to 10 percent of new steady-state value can be used as a proxy for determining this time.

Rise time: The time when the resource has reached 90% of the new steady-state (target) active power output shall be less than 4 seconds, or as otherwise specified by Company.²

Settling Time: Time in which the resource has entered into, and remains within, the settling band of the new steady-state active power (target) output shall be less than 10 seconds, or as otherwise specified by Company.

Overshoot: Percentage of the rated active power output that the resource can exceed while reaching the settling band shall be less than 5% or as otherwise specified by Company.³

Settling Band: Percentage of rated active power output that the resource should settle to within the settling time shall be less than 2.5%.

When operating in parallel with the Company System, the Facility shall operate with its primary frequency response control in automatic operation and in accordance with Company directions. Notification of changes in the status of the frequency response controls and, where applicable, mode of operation must be provided to the Company System Operator immediately through SCADA telemetry indication.

The Facility frequency response control shall adjust, without intentional delay and without regard to the ramp rate limits in Section 3(c) (Ramp Rates) of this Attachment F (Facility Owned by Subscriber Organization), the Facility's net real power export based on frequency deadband and frequency droop settings specified by the Company.

The Facility frequency response control shall increase the net real power export above the Power Reference Setpoint set under Section 1(g)(viii) of this Attachment F (Facility Owned by Subscriber Organization) or further decrease the net real power export from the Power Reference Limit in its operations in accordance with the frequency response settings.

The Facility frequency response control shall be in continuous operation unless directed otherwise by the Company.

(xiii) **[FOR FACILITIES WITH STORAGE].** Alternate Active Power/ Frequency Response Modes. The Facility will provide the capability to supply an isochronous mode of operation, in addition to normal droop, which can be set remotely or locally. The control design shall allow for a bump less transfer between modes of operation.

A. Reserved.

B. Isochronous / Black Start: The Facility will be capable of operating in a zero droop (isochronous) mode of operation. When in this mode of operation, the frequency droop characteristic will be configured as needed to keep system frequency at a target. In a black start configuration, the target shall be 60 Hz. If isochronous is specified while in operation, the target shall be initialized to the grid frequency and the target increased or decreased from the Company System through the control interface.

(h) Control System Acceptance Test Procedures.

(i) Conditions Precedent. The following conditions precedent must be satisfied prior to conducting the Control System Acceptance Test:

² Percentage based on final (expected) settling value.

³ Percentage based on final (expected) settling value.

- Successful completion of the Acceptance Test.
 - Facility has been successfully energized.
 - All of the Facility's generators (as applicable) have been fully commissioned.
 - The control system computer has been programmed for normal operations.
 - All equipment that is relied upon for normal operations (including ancillary devices such as capacitors/inductors, energy storage device, statcom, etc.) shall have been commissioned and be operating within normal parameters.
- (ii) Facility Energy Equipment. In the event that all or any portion of the Facility's energy equipment is not available for the duration of the Control System Acceptance Test, the Control System Acceptance Test will have to be re-run from the beginning unless Subscriber Organization demonstrates to the satisfaction of the Company that the test results attained are consistent with the results that would have been attained if all of the equipment had been available for the duration of the test.
- (iii) Procedures. The Control System Acceptance Test will be conducted on Business Days during normal working hours on a mutually agreed upon schedule. No Control System Acceptance Test will be scheduled during the final 21 Days of a calendar year. No later than thirty (30) Days prior to conducting the Control System Acceptance Test, Company and Subscriber Organization shall agree on a written protocol setting out the detailed procedure and criteria for passing the Control System Acceptance Test. Exhibit F-7 (Control System Acceptance Test Criteria) provides general criteria to be included in the written protocol for the Control System Acceptance Test. Within fifteen (15) Business Days of completion of the Control System Acceptance Test, Company shall notify Subscriber Organization in writing whether the Control System Acceptance Test(s) has been passed and, if so, the date upon which such Control System Acceptance Test(s) was passed. If any changes have been made to the technical specifications of the Facility or the design of the Facility in accordance with Section 5(f) of Exhibit F-1 (Description of Generation and Battery Storage Facility), such changes shall be reflected in an amendment to this Contract, and the written protocol for the Control Systems Acceptance Test shall be based on the Facility as modified. Such amendment shall be executed prior to conducting the Control System Acceptance Test and Company shall have no obligation for any delay in performing the Control Systems Acceptance Test due to the need to complete and execute such amendment.
- (i) Facility Security and Maintenance. Subscriber Organization is responsible for securing the Facility. Subscriber Organization shall have personnel available to respond to all calls related to security incidents and shall take commercially reasonable efforts to prevent any security incidents. Subscriber Organization is also responsible for maintaining the Facility, including vegetation management, to prevent security breaches. Subscriber Organization shall comply with all commercially reasonable requests of Company to update security and/or maintenance if required to prevent security breaches.
- (j) Demonstration of Facility. Company shall have the right at any time, other than during maintenance or other special conditions, communicated by Subscriber Organization, to notify Subscriber Organization in writing of Subscriber Organization's failure, as observed by Company and set forth in such written notice, to meet the operational and performance requirements specified in Section 1(b)(iii)(I), Section 1(g) (Active Power Control Interface) and Section 3 (Performance Standards) of this Attachment F (Facility Owned by Subscriber Organization), and to require documentation or testing to verify compliance with such requirements. Upon receipt of such notice, Subscriber Organization shall promptly investigate the matter, implement corrective action and provide to Company, within thirty (30) Days of such notice, a written report of both the results of such investigation and the corrective action taken by Subscriber Organization; provided, that, if thirty (30) Days is not a reasonable time period to investigate the matter, implement corrective action and provide

such written report, Subscriber Organization shall complete the foregoing within such longer commercially reasonable period of time agreed to by the Parties in writing. If the Subscriber Organization's report does not resolve the issue to Company's reasonable satisfaction, the Parties shall promptly commission a study to be performed by one of the engineering firms then included on the Qualified Independent Third-Party Consultants List attached to the Contract as Exhibit F-2 (Consultants List) to evaluate the cause of the non-compliance and to make recommendations to remedy such non-compliance. Subscriber Organization shall pay for the cost of the study. The study shall be completed within ninety (90) Days, unless the selected consultant determines such study cannot reasonably be completed within ninety (90) Days, in which case, such longer period of time as the selected consultant determines is necessary to complete such study shall apply. The consultant shall send the study to Company and Subscriber Organization. Subscriber Organization (and/or its Third-Party consultants and contractors), at Subscriber Organization's expense, shall take such action as the study shall recommend with the objective of resolving the non-compliance. Such recommendations shall be implemented by Subscriber Organization to Company's reasonable satisfaction no later than forty-five (45) Days from the Day the completed study is issued by the consultant, unless such recommendations cannot reasonably be implemented within forty-five (45) Days, in which case, Subscriber Organization shall implement such recommendations within such longer commercially reasonable period of time agreed to by the Parties in writing. Failure to implement such recommendations within this period shall constitute a material breach of this Contract. Unless the aforementioned written report and study are being completed, and any recommendations are being implemented, solely to address Subscriber Organization's failure to satisfy the requirements of Section 3(w) (Round Trip Efficiency) of this Attachment F (Facility Owned by Subscriber Organization), the Company shall have the right to declare the Facility derated and in Subscriber Organization-Attributable Non-Generation status until the Subscriber Organization's aforementioned written report has been completed, any subsequent study commissioned by the Parties has been completed and any recommendations to resolve the non-compliance have been implemented to Company's reasonable satisfaction.

2. OPERATING PROCEDURES. [NOTE: NUMERICAL SPECIFICATIONS IN THIS SECTION 2 MAY VARY DEPENDING ON THE SPECIFIC PROJECT AND THE RESULTS OF THE PROJECT-SPECIFIC INTERCONNECTION REQUIREMENT STUDY.]

- (a) Reviews of the Facility. Company may require periodic reviews of the Facility, maintenance records, available operating procedures and policies, and relay settings, and Subscriber Organization shall implement changes Company deems necessary for parallel operation or to protect the Company System from damages resulting from the parallel operation of the Facility with the Company System.
- (b) Separation. Subscriber Organization must separate from Company System whenever requested to do so by the Company System Operator pursuant to Section 5. (Company Dispatch) and Section 12. (Personnel and System Safety) of the Contract.
- (c) Subscriber Organization Logs. Logs shall be kept by Subscriber Organization for information on unit availability including reasons for planned and forced outages, circuit breaker trip operations, relay operations, including target initiation, and other unusual events. Company shall have the right to review these logs, especially in analyzing system disturbances. Subscriber Organization shall maintain such records for a period of not less than six (6) years.
- (d) Reclosing and Return to Service. Under no circumstances shall Subscriber Organization, when separated from the Company System for any reason, including tripping during disturbances or due to equipment failure, reclose into the Company System without first obtaining specific approval to do so from the Company System Operator. Ramp rates, behavior and mode of operation upon return to service shall conform to verbal instructions from the System Operator or Active Power control from Company. Following "system black" conditions, the Facility shall not

attempt to automatically reconnect to the grid (unless directed by the Company System Operator) so as to not interfere with blackstart procedures.

- (e) Reserved.
- (f) Reserved.
- (g) Critical Infrastructure Protection. Subscriber Organization shall comply with the critical infrastructure protection requirements set forth in Section 1(b) (iii) (G) of this Attachment F (Facility Owned by Subscriber Organization).
- (h) Allowed Operations. Facility shall be allowed to export energy to the Company System only when the [] circuit is in normal operating configuration served by breaker [] at [] Substation. **[TO BE DETERMINED BY COMPANY BASED ON THE RESULTS AND REQUIREMENTS OF THE IRS]**

3. PERFORMANCE STANDARDS. [NOTE: FACILITIES CONNECTING TO THE DISTRIBUTION SHALL FOLLOW THE PERFORMANCE STANDARDS FOR DISTRIBUTION SET FORTH BELOW. FACILITIES CONNECTING TO THE SUB-TRANSMISSION SHALL FOLLOW THE PERFORMANCE STANDARDS FOR SUB-TRANSMISSION SET FORTH BELOW.]

[DRAFTING NOTE: COMPANY RETAINS SOLE DISCRETION TO CONSIDER THE LESS STRINGENT REQUIREMENTS (WHICH ARE INCLUDED IN THE FIRST SET OF ALTERNATIVE PERFORMANCE STANDARD PROVISIONS UNDER 3. (a) THROUGH (g)) FOR PROJECTS THAT DO NOT EXCEED 1 MW].

PROVISIONS FOR DISTRIBUTION CONNECTION (THESE WILL BE DELETED IF FACILITY IS CONNECTING TO SUB-TRANSMISSION)

- (a) Rule 14H. The Facility shall follow the performance standards of Rule 14H Appendix I and the additional provisions set forth below in Section 3(b) (Voltage Ride-Through) through Section 3(g) (Unintentional Islanding). To the extent any of those additional provisions conflict with Rule 14H, the additional provisions of Section 3(b) through Section 3(g) shall control.
- (b) Voltage Ride-Through. Whenever the utility Distribution System voltage at the Point of Interconnection varies from and remains outside the normal operating high and normal operating low region voltage for the predetermined parameters set forth in Table 4A-1.1. The Facility's protective functions shall cause the Facility's Advanced Inverter(s) to Cease to Energize the utility Distribution System. Unless provided alternate settings by the Company, the Facility must comply with the voltage ride-through and trip settings specified in Table 4A-1.1:
 - 1. The Facility shall stay connected to the utility Distribution System while the grid remains within the "Ride-Through Until" voltage-time range and must operate in accordance with the "Operating Mode" specified for each "Operating Region".
 - 2. In the Continuous Operation region, the Facility's Advanced Inverter shall reduce power output as a function of voltage, in accordance with section (iv) Volt-Watt of Rule 14H.
 - 3. Different settings than those specified in Table 4A-1.1 may be specified by the Company

TABLE 4A-1.1: VOLTAGE RIDE-THROUGH TABLE				
Operating Region	Voltage at Point of Interconnection (% of Nominal Voltage)	Operating Mode	Ride Through Until (s)	Default Maximum Trip Time (s)
OV2	$V > 120$	Cease to Energize	N/A	0.16 (1)
OV1	$120 \geq V > 110$	Mandatory operation	.92	1
CO	$110 \geq V > 100$	Continuous Operation (Volt-Watt)	N/A	N/A
CO	$100 > V \geq 88$	Continuous Operation	N/A	N/A
UV1	$88 > V \geq 70$	Mandatory Operation	20	21
UV2	$70 > V \geq 50$	Mandatory Operation	10-20	11-21(2)
UV3	$50 > V$	Momentary Cessation	N/A	2

⁽¹⁾Must trip time under steady state condition. Inverters will also be required to meet the Company's Transient Overvoltage criterion (TrOV-2) or Limitation of overvoltage contribution requirement stated in IEEE 1547-2018 (or latest version), "IEEE Standard for Interconnection and Interoperability of Distributed Energy Resources with Associated Electric Power System Interfaces." Ride-Through shall not inhibit TrOV-2 or limitation of overvoltage contribution of IEEE 1547-2018 requirements.

⁽²⁾May be adjusted within these ranges at manufacturer's discretion.

- (c) **Fault Ride Through.** For fault-related voltage dips at the Point of Interconnection that stay within the limits of the under voltage ride-through requirements in Section 3(b) (Voltage Ride-Through), upon clearing of the fault, Subscriber Organization shall within 1 second of restoration, provide at least 90% of the real power output at the point of interconnection immediately before the fault to the extent allowed by the availability of the solar resource. The fault ride through requirement does not apply if the Generating Facility is operating at less than five percent (5%) of the Generating Facility's nameplate capacity.
- (d) **Grid Forming Capabilities.** **[NOTE APPLICABILITY BASED ON RESOURCE TYPE AND DESIGN, FOR PV INVERTER BASED RESOURCES PAIRED WITH STORAGE, TO BE DELETED IF SUBSCRIBER ORGANIZATION DOES NOT PROPOSE GRID FORMING]** Subscriber Organization Facility inverters shall be capable of operating in grid forming mode supporting system operation under normal and emergency conditions without relying on the characteristics of synchronous machines. This includes operation as a current independent AC voltage source during normal and transient conditions (as long as no limits are reached within the inverter) and the ability to synchronize to other voltage sources or operate autonomously if a grid reference is unavailable.
 - (i) Subscriber Organization shall operate the Facility in grid forming mode only as directed by the Company System Operator, in its sole discretion. Such mode of operation shall be indicated to the Company System Operator through telemetry.
 - (ii) The Facility shall include safeguards to prevent the unintentional switching of the Facility into and out of grid forming mode. The safeguards shall be approved in writing by the Company and implemented by the Subscriber Organization prior to control system testing.

- (e) Black Start Capability. [NOTE - APPLICABILITY BASED ON RESOURCE TYPE AND DESIGN, FOR PV INVERTER BASED RESOURCES PAIRED WITH STORAGE, TO BE DELETED IF SUBSCRIBER ORGANIZATION DOES NOT PROPOSE BLACK START] The BESS shall be capable of grid forming inverter capability so it can generate its own AC waveform rather than relying on a grid voltage to synchronize and maintain frequency. Further, inverter-based resources shall ensure they have sufficient energy storage to maintain power injection to the grid during system restoration (i.e., have power available when and if called upon). Inverter based facilities should be capable of support as a black start cranking path to start synchronous generators for restoration.
- (f) Frequency Response. Subscriber Organization shall comply with the requirements of Section 1(g) (xi) (Frequency Response (DROOP)), Section 1(g) (xii) (Dynamic Active Power – Frequency Performance), and [FOR FACILITIES WITH STORAGE] Section 1(g) (xiii) (Alternate Active Power / Frequency Response Modes) of this Attachment F (Facility Owned by Subscriber Organization).
- (g) Unintentional Islanding. A Facility's inverters shall be certified to meet the unintentional islanding requirement stated in IEEE 1547-2018 (or latest version), "IEEE Standard for Interconnection and Interoperability of Distributed Energy Resources with Associated Electric Power System Interfaces." Ride through requirements specified herein shall not inhibit the islanding detection performance where a valid unintentional islanding condition exists.

4. **MAINTENANCE OF SUBSCRIBER ORGANIZATION-OWNED INTERCONNECTION FACILITIES.**

- (a) Subscriber Organization must address any Disconnection Event (as defined below) according to the requirements of this Section 4 (Maintenance of Subscriber Organization-Owned Interconnection Facilities) of Attachment F (Facility Owned by Subscriber Organization). For the purposes of this Section 4 (Maintenance of Subscriber Organization-Owned Interconnection Facilities), a "Disconnection Event" is the removal of 80% of capacity or more from Company System and/or disconnection of the Facility from the Company's System (i) that is not the result of Company dispatch, frequency droop response, or isolation of the Facility resulting from designed protection fault clearing, and (ii) for which Company does not issue the written notice for failure to meet operational and performance requirements as set forth in Section 1(j) (Demonstration of Facility) of this Attachment F (Facility Owned by Subscriber Organization). Company's election to exercise its rights under Section 1(j) (Demonstration of Facility) shall not relieve Subscriber Organization of its obligation to comply with the requirements of this Section 4 (Maintenance of Subscriber Organization-Owned Interconnection Facilities) for any future Disconnection Event during the pendency of such election or thereafter.
- (b) For every Disconnection Event from the Company System, Subscriber Organization shall investigate the cause. Within three (3) Business Days, Subscriber Organization shall provide, in writing to Company, an incident report that summarizes the sequence of events and probable cause.
- (c) Within forty-five (45) Days of a Disconnection Event, Subscriber Organization shall provide, in writing to Company, Subscriber Organization's findings, data relied upon for such findings, and proposed actions to prevent reoccurrence of a Disconnection Event ("Proposed Actions"). Company may assist Subscriber Organization in determining the causes of and recommendations to remedy or prevent a Disconnection Event ("Company's Recommendations"). Subscriber Organization shall implement such Proposed Actions (as modified to incorporate the Company's Recommendations, if any) and Company's Recommendations (if any) in accordance with the time period agreed to by the Parties.

- (d) In the event Subscriber Organization and Company disagree as to (i) whether a Disconnection Event occurred, (ii) the sequence of events and/or probable cause of the Disconnection Event, (iii) the Proposed Actions, (iv) Company's Recommendations, and/or (v) the time period to implement the Proposed Actions and/or Company's Recommendations, then the Parties shall follow the procedure set forth in Section 5 (Expedited Dispute Resolution) of this Attachment F (Facility Owned by Subscriber Organization).
- (e) Upon the fourth (4th) Disconnection Event (and each subsequent Disconnection Event) within any Contract Year, the Parties shall follow the procedures set forth in Section 4(a) and Section 4(d) of Attachment F (Facility Owned by Subscriber Organization), to the extent applicable. If after following the procedures set forth in this Section 4 (Maintenance of Subscriber Organization-Owned Interconnection Facilities) of Attachment F (Facility Owned by Subscriber Organization), Subscriber Organization and Company continue to have a disagreement as to (1) the probable cause of the Disconnection Event, (2) the Proposed Actions, (3) the Company's Recommendations, and/or (4) the time period to implement the Proposed Actions and/or the Company's Recommendations, then the Parties shall commission a study to be performed by a qualified independent Third-Party consultant ("Qualified Consultant") chosen from the Qualified Independent Third-Party Consultants List ("Consultants List") attached to the Contract as Exhibit F-2 (Consultants List). Such study shall review the design of, review the operating and maintenance procedures dealing with, recommend modifications to, and determine the type of maintenance that should be performed on Subscriber Organization-Owned Interconnection Facilities ("Study"). Subscriber Organization and Company shall each pay for one-half of the total cost of the Study. The Study shall be completed within ninety (90) Days from such fourth Disconnection Event (and each subsequent Disconnection Event) within any Contract Year, unless the Qualified Consultant determines the Study cannot reasonably be completed within ninety (90) Days, in which case, such longer period of time as the Qualified Consultant determines is necessary to complete the Study shall apply. The Qualified Consultant shall send the Study to Company and Subscriber Organization. Subscriber Organization (and/or its Third-Party consultants and contractors), at Subscriber Organization's expense, shall change the design of, change the operating and maintenance procedures dealing with, implement modifications to, and/or perform the maintenance on Subscriber Organization-Owned Interconnection Facilities recommended by the Study. Such design changes, operating and maintenance procedure changes, modifications, and/or maintenance shall be completed no later than forty-five (45) Days from the Day the completed Study is issued by the Qualified Consultant, unless such design changes, operating and maintenance procedure changes, modifications, and/or maintenance cannot reasonably be completed within forty-five (45) Days, in which case, Subscriber Organization shall complete the foregoing within such longer commercially reasonable period of time agreed to by the Parties in writing. Company shall have the right to derate the Facility to a level that maintains reliable operations in accordance with Good Engineering and Operating Practices, and the Facility shall be deemed to be in Subscriber Organization-Attributable Non-Generation status, until the study has been completed and the study's recommendations have been implemented by Subscriber Organization to Company's reasonable satisfaction. Nothing in this provision shall affect Company's right to dispatch the Facility as provided for in this Contract.
- (f) The Consultants List attached hereto as Exhibit F-2 (Consultants List) contains the names of engineering firms which both Parties agree are fully qualified to perform the Study. At any time, except when a Study is being conducted, either Party may remove a consultant from the Consultants List by giving written notice of such removal to the other Party. However, neither Party may remove a name or names from the Consultants List without approval of the other Party if such removal would leave the list without any names. Intended deletions shall be effective upon receipt of notice by the other Party, provided that such deletions do not leave the Consultants List without any names. Proposed additions to the Consultants List shall automatically become effective thirty (30) Days after notice is received by the other Party unless written objection is made by such other Party within said thirty (30) Day period. By mutual agreement between the Parties, a new name or names may be added to the Consultants List at any time.

5. **EXPEDITED DISPUTE RESOLUTION.**

If there is a disagreement between Company and Subscriber Organization regarding (i) whether a Disconnection Event occurred, (ii) the sequence of events and/or probable cause of the Disconnection Event, (iii) the Proposed Actions, (iv) the Company's Recommendations, and (v) the time period to implement the Proposed Actions and/or the Company's Recommendations, then authorized representatives from Company and Subscriber Organization, having full authority to settle the disagreement, shall meet in Hawai'i (or by telephone conference) and attempt in good faith to settle the disagreement. Unless otherwise agreed in writing by the Parties, the Parties shall devote no more than five (5) Business Days to settle the disagreement in good faith. In the event the Parties are unable to settle the disagreement after the expiration of the time period, then such disagreement shall constitute a Dispute for which either Party may pursue the dispute resolution procedure set forth in Section 17. (Dispute Resolution) of this Contract.

6. **MODELING.**

(a) Subscriber Organization's Obligation to Provide Models. Within 30 Days of Company's written request, but no later than the Commercial Operations Date, Subscriber Organization shall provide detailed data regarding the design and location of the Facility, in a form reasonably satisfactory to Company, to allow the modeling of the inverters and any other equipment within the Facility identified in the IRS which utilizes Source Code (such as energy storage system, STATCOM or DVAR equipment), including, but not limited to, integrated and validated power flow and transient stability models (such as PSS/E models), a short circuit model (such as an ASPEN model), and an electromagnetic transient model (such as a PSCAD model) of the inverters and any additional equipment identified in the IRS as set forth above, applied assumptions, and pertinent data sets (each a "Required Model" and collectively, the "Required Models"). Thereafter, during the Term, Subscriber Organization shall provide working updates of any Required Model within 30 Days of (i) Company's written request, or (ii) Subscriber Organization obtaining knowledge or notice that any Required Model has been modified, updated or superseded by the Source Code Owner.

(b) Escrow Establishment. If, pursuant to Section 6(a) (Subscriber Organization's Obligation to Provide Models) of this Attachment F (Facility Owned by Subscriber Organization), the Required Models are provided to the Company in a form other than Source Code, Subscriber Organization shall arrange for and ensure that the Source Code for the relevant Required Model is deposited into the Source Code Escrow as set forth below in Section 6(b)(i) (Source Code Escrow) of this Attachment F (Facility Owned by Subscriber Organization) no later than the time periods set forth in Section 6(a) (Subscriber Organization's Obligation to Provide Models) of this Attachment F (Facility Owned by Subscriber Organization) for delivery of the Required Models. Subscriber Organization shall be responsible for all costs associated with establishing and maintaining the Source Code Escrow. If, however, Subscriber Organization is unable to deposit the required Source Code into the Source Code Escrow within the time periods set forth in Section 6(a) (Subscriber Organization's Obligation to Provide Models), Subscriber Organization shall, no later than such time periods, instead establish a monetary escrow as set forth below in Section 6(b)(ii) (Monetary Escrow) of this Attachment F (Facility Owned by Subscriber Organization).

(i) Source Code Escrow.

(A) Establishment of Source Code Escrow. If the Required Models are not provided to the Company in the form of Source Code pursuant to Section 6(a) of this Attachment F (Facility Owned by Subscriber Organization), Subscriber Organization shall: (a) arrange for and ensure the deposit of a copy of the current version of the Source Code and relevant documentation for all Required Models with the Source Code Escrow Agent under the terms and conditions of the Source Code Escrow Agreement, and (b) arrange for and ensure the update of the deposited Source Code and relevant documentation for Major Releases and Minor Releases of the Required Models as soon as reasonably possible after they are made generally available.

(B) Release Conditions. Company shall have the right to obtain from the Source Code Escrow Agent one copy of the escrowed Source Code for the Required Models, under the following conditions upon Company's request:

(i) A receiver, trustee, or similar officer is appointed, pursuant to federal, state or applicable foreign law, for the Source Code Owner;

(ii) Any voluntary or involuntary petition or proceeding is instituted, under (x) U.S. bankruptcy laws or (y) any other bankruptcy, insolvency or similar proceeding outside of the United States, by or against the Source Code Owner; or

(iii) Failure of the Source Code Owner to function as a going concern or operate in the ordinary course; or

(iv) Subscriber Organization and the Source Code Owner fail to provide to Company the Required Models or updated Required Models, or, alternatively, fail to issue a Source Code LC, within the time periods set forth in Section 6(a) (Subscriber Organization's Obligation to Provide Models) of this Attachment F (Facility Owned by Subscriber Organization), Company gives written notice of such failure to Subscriber Organization and the Source Code Owner, and Subscriber Organization and Source Code Owner fail to remedy such breach within five (5) Days following receipt of such notice.

(C) Remedies. If Company has the right to obtain from the Source Code Escrow Agent one copy of the escrowed Source Code for the Required Models pursuant to Section 6(b)(i)(B) (Release Conditions) of Attachment F (Facility Owned by Subscriber Organization), and Company finds that Subscriber Organization failed to arrange for and ensure the update the Source Code Escrow with the modified and/or updated Source Code and relevant documentation for Major Releases and Minor Releases of the Required Models as provided in Section 6(b)(i) (Establishment of Source Code Escrow) of Attachment F (Facility Owned by Subscriber Organization) or that the Source Code for the Required Models is incomplete or otherwise unusable, Subscriber Organization shall be liable to Company for liquidated damages in the amount of \$500 per Day for each Day Subscriber Organization fails to provide such Source Code to Company or such update to the Source Code to Company from the date such Major Release or Minor Release was first made available by the Source Code Owner to customers of the Source Code Owner. Failure to provide the updated Source Code of the Required Models within 30 Days' notice from Company of a breach of Section 6(b)(i)(A) (Establishment of Source Code Escrow) of Attachment F (Facility Owned by Subscriber Organization); provided, that Subscriber Organization has also failed to provide a satisfactory Source Code LC as set forth in Section 6(b)(ii) (Source Code Security) of this Attachment F (Facility Owned by Subscriber Organization) shall constitute an Event of Default pursuant to Section 13, under the Contract.

(D) Certification. The Source Code Escrow Agent shall release the Source Code of the Required Models to Company upon receipt of a signed statement by a representative of Company that reads substantially as follows:

For Maui Facilities: The undersigned hereby certifies that (i) I am duly authorized to execute this document on behalf of Maui Electric Company, Limited ("Maui Electric"), and (ii) Maui Electric is entitled to a copy of the Source Code of the Required Models Pursuant to Section 6(b)(i)(B) (Release Conditions) of Attachment F (Facility Owned by Subscriber Organization) of the Mid-Tier Standard Form Contract for Renewable Dispatchable Generation dated as of _____, between _____, and Maui Electric.

For Hawai'i Facilities: The undersigned hereby certifies that (i) I am duly authorized to execute this document on behalf of Hawai'i Electric Light Company, Inc. ("Hawai'i Electric Light"), and (ii) Hawai'i Electric Light is entitled to a copy of the Source Code of the Required Models Pursuant to Section 6(b)(i)(B) (Release Conditions) of Attachment F (Facility Owned by Subscriber Organization) of the Mid-Tier Standard Form Contract for

Renewable Dispatchable Generation dated as of _____, between _____, and Hawai'i Electric Light.

(E) Authorized Use. If Company becomes entitled to a release of the Source Code of the Required Models from escrow, Company may thereafter correct, modify, update and enhance the Required Models for the sole purpose of providing itself the support and maintenance it otherwise would have been entitled to if it had been provided the Required Models by Subscriber Organization under Section 6(a) (Subscriber Organization's Obligation to Provide Models) of this Attachment F (Facility Owned By Subscriber Organization) (the "Source Code Authorized Use").

(F) Confidentiality Obligations. Company shall keep the Source Code of the Required Models confidential pursuant to the confidentiality obligations of the Source Code Escrow Agreement. Company shall restrict access to the Source Code of the Required Models to those employees, independent contractors and consultants of Company who have agreed in writing to be bound by confidentiality and use obligations consistent with those specified in the Escrow Agreement, and who have a need to access the Source Code of the Required Models on behalf of Company to carry out their duties for the Source Code Authorized Use. Promptly upon Subscriber Organization's request, Company shall provide Subscriber Organization with the names and contact information of all individuals who have accessed the Source Code of the Required Models, and shall take all reasonable actions required to recover any such Source Code in the event of loss or misappropriation, or to otherwise prevent their unauthorized disclosure or use.

(ii) Source Code Security.

(A) Establishment of Source Code Security. If the Required Models and their relevant Source Code are not provided to the Company in the form of Source Code pursuant to Section 6(a) (Subscriber Organization's Obligation to Provide Models) of this Attachment F (Facility Owned by Subscriber Organization) and if the Subscriber Organization is unable to arrange for and ensure the deposit of the Source Code into the Source Code Escrow established for the benefit of the Company pursuant to Section 6(b)(i) (Source Code Escrow) of this Attachment F (Facility Owned by Subscriber Organization) then, no later than the time periods set forth in Section 6(a) (Subscriber Organization's Obligation to Provide Models) of this Attachment F (Facility Owned by Subscriber Organization) for delivery of the Required Models and Source Code, Subscriber Organization shall provide an irrevocable standby letter of credit (the "Source Code LC") with no documentation requirement in the amount of Two Hundred Fifty Thousand Dollars (\$250,000) per Required Model (and its relevant Source Code) substantially in the form attached to this Contract as Exhibit G-1 (Form of Letter of Credit) from a bank chartered in the United States with a credit rating of "A-" or better from Standard & Poor's or A3 or better from Moody's. Such letter of credit shall be issued for a minimum term of one (1) year. Furthermore, at the end of each year the security shall be renewed for an additional one (1) year term so that at the time of such renewal, the remaining term of any such security shall not be less than one (1) year. The letter of credit shall include a provision for at least thirty (30) Days' advance notice to Company of any expiration or earlier termination of the letter of credit so as to allow Company sufficient time to exercise its rights under said security if Subscriber Organization fails to extend or replace the security. In all cases, the reasonable costs and expenses of establishing, renewing, substituting, canceling, increasing, reducing, or otherwise administering the letter of credit shall be borne by Subscriber Organization.

(B) Release Conditions. Company shall have the right to draw on the letter of credit the funds necessary to develop and recreate the Required Model or Required Models upon Company's request if Subscriber Organization fails to provide the Company the Required Models or updated Required Models within the time periods set forth in Section 6(a) (Subscriber Organization's Obligation to Provide Models) or Section 6(b)(i)(C) (Remedies) of this Attachment F (Facility Owned by Subscriber Organization), Company gives written notice of such failure to Subscriber Organization, and Subscriber Organization fails to remedy such breach within five (5) Days following receipt of such notice for a breach under Section 6(a) (Subscriber Organization's Obligation to Provide Models), or within thirty (30) Days following receipt of such notice for a breach under Section 6(b)(i)(C) (Remedies).

(C) Extend Letter of Credit. If the letter of credit is not renewed or extended no later than thirty (30) Days prior to its expiration or earlier termination, Company shall have the right to draw immediately upon the full amount of the letter of credit and to place the proceeds of such draw (the “Proceeds”), at Subscriber Organization’s cost, in an escrow account in accordance with Section 6(b)(ii)(D) (Proceeds Escrow), until and unless Subscriber Organization provides a substitute form of letter of credit meeting the requirements of this Section 6(b)(ii) (Source Code Security) of this Attachment F (Facility Owned by Subscriber Organization).

(D) Proceeds Escrow. If Company draws on the letter of credit pursuant to Section 6(b)(ii)(C) (Extend Letter of Credit) of this Attachment F (Facility Owned by Subscriber Organization), Company shall, in order to avoid comingling the Proceeds, have the right but not the obligation to place the Proceeds in an escrow account as provided in this Section 6(b)(ii)(D) (Proceeds Escrow) of this Attachment F (Facility Owned by Subscriber Organization) with a reputable escrow agent acceptable to Company (“Proceeds Escrow Agent”) subject to an escrow agreement acceptable to Company (“Proceeds Escrow Agreement”). Without limitation to the generality of the foregoing, a federally insured bank shall be deemed to be a “reputable escrow agent.” Company shall have the right to apply the Proceeds as necessary to recover amounts Company is owed pursuant to this Section 6 (Modeling) of this Attachment F (Facility Owned by Subscriber Organization). To that end, the Proceeds Escrow Agreement governing such escrow account shall give Company the sole authority to draw from the account. Subscriber Organization shall not be a party to such Proceeds Escrow Agreement and shall have no rights to the Proceeds. Upon full satisfaction of Subscriber Organization’s obligations under Section 6 (Modeling) of this Attachment F (Facility Owned by Subscriber Organization), Company shall instruct the Proceeds Escrow Agent to remit to the bank that issued the letter of credit that was the source of the Proceeds the remaining balance (if any) of the Proceeds. If there is more than one escrow account with Proceeds, Company may, in its sole discretion, draw on such accounts in any sequence Company may select. Any failure to draw upon the Proceeds for any damages or other amounts due Company shall not prejudice Company’s rights to recover such damages or amounts in any other manner.

(E) Subscriber Organization’s Obligation. If the letter of credit is not sufficient to cover Company’s associated consultant fees, costs and expenses to develop and recreate the Required Models, Subscriber Organization shall pay to Company the difference within ten (10) Days of Company’s written notice to Subscriber Organization.

(F) Model Verification. Subscriber Organization shall work with the Company to validate the new Required Models developed by or on behalf of Company within sixty (60) Days of receiving such new Required Models. Subscriber Organization shall also arrange for and ensure that Company may obtain new Required Models directly from the Source Code Owner in the event that Subscriber Organization ceases to operate as a going concern or is subject to voluntary or involuntary bankruptcy and is unable or unwilling to obtain the new Required Models from the Source Code Owner.

(G) Certification. The terms of the letter of credit shall provide for a release of the funds, or in the event the funds have been placed into a Proceeds Escrow, the Proceeds Escrow Agent shall release the necessary funds to Company upon receipt of a signed statement by a representative of Company that reads substantially as follows:

For Maui Facilities: The undersigned hereby certifies that (i) I am duly authorized to execute this document on behalf of Maui Electric Company, Limited (“Maui Electric”), and (ii) Maui Electric is entitled to \$ _____, pursuant to Section 6(b)(ii)(B) (Release Conditions) of Attachment F (Facility Owned by Subscriber Organization) of the Mid-Tier Standard Form Contract for Renewable Dispatchable Generation dated as of _____, between _____, and Maui Electric.

For Hawai‘i Facilities: The undersigned hereby certifies that (i) I am duly authorized to execute this document on behalf of Hawai‘i Electric Light Company, Inc. (“Hawai‘i Electric Light”), and (ii) Hawai‘i Electric Light is entitled to \$ _____, pursuant to Section 6(b)(ii)(B) (Release Conditions) of Attachment F (Facility Owned by Subscriber Organization)

of the Mid-Tier Standard Form Contract for Renewable Dispatchable Generation dated as of _____, between _____, and Hawai'i Electric Light.

(H) Authorized Use. If Company becomes entitled to a draw of funds from the Source Code Security or a release of funds from the Proceeds Escrow, Company may thereafter use such funds to develop, recreate, correct, modify, update and enhance the Required Models for the sole purpose of providing itself the support and maintenance it otherwise would have been entitled to if it had been provided the Required Models by Subscriber Organization under Section 6(a) (Subscriber Organization's Obligation to Provide Models) of this Attachment F (Facility Owned by Subscriber Organization).

- (iii) Supplementary Agreement. The parties stipulate and agree that the escrow provisions in this Section 6(b) (Escrow Establishment) of Attachment F (Facility Owned by Subscriber Organization) and the Source Code Escrow Agreement and Proceeds Escrow Agreement are "supplementary agreements" as contemplated in Section 365(n) (1) (B) of the Code. In any voluntary or involuntary bankruptcy proceeding involving Subscriber Organization, failure by Company to assert its rights to "retain its rights" to the intellectual property encompassed by the Source Code or the funds in the Proceeds Escrow, pursuant to Section 365(n) (1) (B) of the Code, under an executory contract rejected in a bankruptcy proceeding, shall not be construed as an election to terminate the contract by Company under Section 365(n) (1) (A) of the Code.

7. TESTING REQUIREMENTS.

- (a) Testing Requirements. Once the Control System Acceptance Test has been successfully passed, Subscriber Organization shall not replace and/or change the configuration of the Facility Control, inverter control settings and/or ancillary device controls, without prior written notice to Company. In the event of any such replacement and/or change, the relevant test(s) of the Control System Acceptance Test shall be redone and must be successfully passed before the replacement or altered equipment is allowed to be placed in normal operations. In the event that Company reasonably determines that such replacement and/or change of controls makes it inadvisable for the Facility to continue in normal operations without a further Control Systems Acceptance Test, the Facility shall be deemed to be in Subscriber Organization-Attributable Non-Generation status until the new relevant tests of the Control System Acceptance Test have been successfully passed.
- (b) Periodic Testing. Subscriber Organization shall coordinate periodic testing of the Facility with Company to ensure that the Facility is meeting the performance standards specified under this Contract.

8. DATA AND FORECASTING.

Subscriber Organization shall provide Site, meteorological and production data in accordance with the following requirements:

- (i) Physical Site Data: Subscriber Organization shall provide Company with an accurate description of the physical Site, including but not limited to the following, **[as appropriate to Facility resource type(s) and use of storage]** which may not be changed during the Term without Company's prior written consent:

Location Facility Map showing the layout of the Facility (coverage area or footprint) and the coordinates (latitude and longitude) of generating equipment:

Solar PV: elevation (above ground), orientation angle and direction (north-east-south-west plane) of arrays/concentrators.

Wind Generators: coordinates (latitude and longitude) and height above ground of each wind turbine hub.

Location (latitude and longitude) and elevation (above ground) of each MMT/MMS and elevation (above ground) of each field measurement device for, e.g., air density, ambient air pressure and ambient air temperature, located at each MMT or each field measurement device located on such MMS.

For solar resource inverters: Inverter type, power rating, array configuration to inverters and DC rating of the Facility at the following standard test conditions: irradiance of 1000 W/m², air mass 1.5, and cell temperature 25° C.

Solar generation technology employed at the Facility with temperature dependence, mounting and module type.

Wind generation technology employed at the Facility with representative power curve(s).

BESS technology and related auxiliary equipment, location and type.

(ii) Meteorological and Production Data:

Subscriber Organization shall install and maintain a minimum of two MMS for facilities that have either (i) a DC rating of the Facility of 5 MW or greater or (ii) a coverage area greater than one square kilometer.

Placement of each MMS should account for the microclimate of the area and Facility coverage area and shall be oriented with respect to the primary wind direction.

Subscriber Organization shall provide to Company, via SCADA communication and protocol acceptable to Company to support operations and forecasting needs at a continuous scan, all meteorological and production data required under this Contract updated every 2 seconds.

Subscriber Organization shall arrange for a dedicated distribution voltage line to provide separate service from Company, or for such other independent, backup power source as approved by Company in writing, to temporarily store and record the meteorological data from the field measuring devices at the MMSs. Any such backup power source must be capable of providing power for the field measurement devices for a reasonable period of time until primary power is restored. The same backup power source can serve multiple MMSs as needed by the Facility.

(c) Units and Accuracy:

[For PV] The Table below shows minimum required solar irradiance measurements for various types of solar generation technology. **[DRAFTING NOTE: VALUES NEED TO BE INSERTED INTO TABLE.]** This value may not be derived.

Solar Technology	Direct Normal Irradiance	Global Irradiance (GHI)	Plane of Array Irradiance (POA)
Flat Plate (fixed horizontal, fixed angle, tracking, roof mounted)		X	X
Flat Panel Solar Thermal (fixed angle, roof mounted, tracking)	X		X
Concentrated PV (flat, trough, tracking)	X	X	X

Units and accuracy of measured parameters to be provided to Company in real time shall be as shown in the Table below. These represent the minimum required accuracies.

Parameter	Measurement Device (typical)	Unit	Range	Accuracy
Global Horizontal Irradiance at MMS	Pyranometer or equivalent	W/m ²	0 to 1500 W/m ²	Secondary standard per ISO 9060 or ≤ 3% from 100 W/m ² to 1500 W/m ² if using a PV Reference Cell
Plane of Array Irradiance on same axis as array	Pyranometer or equivalent	W/m ²	0 to 1500 W/m ²	Secondary standard per ISO 9060 or ≤ 3% from 100 W/m ² to 1500 W/m ² if using a PV Reference Cell
Back of Panel temperature at array height	Temperature probe	°C	-20 to +50 °C	+/-1 °C
Ambient air temperature at MMS	Temperature probe	°C	-20 to +50 °C	+/-1 °C
Ambient air pressure at MMS	Piezoresistive transducer or equivalent	mbar	150 to 1150 mbar	+/-60 mbar (0 to +50°C)
Wind speed at MMS	Anemometer, sonic device or equivalent	mph	0 to 134 mph	+/-1 mph
Wind direction at MMS	Vane, sonic device or equivalent	Degrees (from True North)	360°	+/-5°
Set point for each inverter	Reported by Subscriber Organization	MW	0 to inverter name plate	Not applicable
DC Power production of Facility at BESS Interface	Measured at Facility's DC input to the BESS charging system	MW (delivered to BESS is positive)	Up to Maximum Rated Input/Output	The lesser of the tolerances of the /telemetry equipment or 2% of measurement
Facility power production ratio	Ratio of Facility's power production (MW)/Allowed Capacity (MW)	%	0 to 100%	+/-0.1 %
Inverters Available	NA	NA	Up to the number installed inverters	
Facility Inverter Availability	Ratio of inverters online/number of inverters	%	0 to 100%	
Power Possible	Subscriber Organization's Model	MW	0 to Allowed Capacity	+/-4%

(d) Status of Generating Equipment:

For each inverter, or wind turbine, Subscriber Organization shall provide to Company, via SCADA communication and protocol acceptable to Company at a continuous scan updated not less frequently than every 2 seconds, a signal as to whether such inverter is available or unavailable, and on or offline.

(e) Data Collection.

[NOTE COMPANY TO UPDATE REQUIREMENTS; WILL BE SPECIFIC TO FACILITY EQUIPMENT AND RESOURCE TYPE]

- High Resolution Data: Subscriber Organization shall install and make available to the Company time stamped and sequential data recordings for all inverter-based resources (and all generating resources) to perform event analysis and verify Facility performance during steady state and transient disturbance events. This will include a time-synchronized phasor measurement unit at the Facility, and access to multiple sources to provide sufficient clarity as to any abnormal response or behavior within the Facility, including Facility control settings and static values, SCADA data, sequence of events recording (SER) data, dynamic disturbance recorder (DDR) data, and inverter fault codes and inverter-level dynamic recordings. This data will be used to review the Facility response to system dynamics, such as the frequency response (normal droop), reactive response, etc.
- Plant Data: **[Note: specific requirements below are representative of variable energy resources and will be tailored to the Facility resource type(s) and geographic arrangement]**

Subscriber Organization shall install at least three (3) meteorological tower(s), spaced so as to provide the data points set forth below for the entire Facility. At least two months prior to the Commercial Operation Date, Subscriber Organization shall deliver to Company a report showing (i) manufacturer, model and year of all energy equipment (panels, inverters, energy storage devices, turbine generators), and meteorological instrumentation, and (ii) the latitude and longitude of the center of the energy equipment (i.e., solar panels for every inverter, wind turbines) and every meteorological tower. Beginning upon COD, Subscriber Organization shall transmit and provide to Company the real-time data set forth below, refreshed as frequently as allowed by the SCADA system, not to exceed sixty (60) second intervals:

- Three (3) data points from each inverter or wind turbine:
 - Inverter/turbine generation (MW)
 - Inverter/turbine availability
 - Inverter/turbine on/offline status
- Two (2) data points from each meteorological tower (solar resources):
 - Global horizontal solar irradiance (instantaneous solar intensity, full sky)
 - Plane of array solar irradiance (instantaneous solar intensity at the current angle of the PV array)
- Five data points from each Meteorological Tower (wind resources):

- Wind Speed ** (mps)
- Wind Direction** (degrees relative to true north)
- Temperature (Celsius)
- Pressure (mb)
- Air Density (kg/m3)

In addition to the other requirements for data collection, if required by Company, a Facility with wind turbines shall install, maintain and operate at least one meteorological tower that is installed at hub height and is placed upstream of the prevailing wind path to provide meteorological data through a means agreed by the Company. The data stream from this meteorological tower to the Company's System must be reliable and include battery back-up at the meteorological tower and a local source of electricity to power the data collection and communication from the Facility to Company during transmission outages.

Subscriber Organization shall provide a map and key for each inverter or wind turbine sufficient to allow Company to correlate the data received through Company's data historian system to each individual resource.

9. **TECHNOLOGY SPECIFIC REQUIREMENTS.**

- (a) [RESERVED]
- (b) [RESERVED]
- (c) Inverter Systems.
 - (i) Direct current generators and non-power (i.e., other than 60 Hertz) alternating current generators can only be installed in parallel with the Company System using a non-islanding synchronous inverter unless alternate designs are approved by the Company. The design shall comply with the requirements of IEEE Std 1547-2003 (or latest version), except as described in Section 3 (Performance Standards) of this Attachment F (Facility Owned by Subscriber Organization).
 - (ii) Self-commutated inverters of the Company-interactive type shall synchronize to the Company System. Line-commutated, thyristor-based inverters are not recommended and will require additional technical study to determine harmonic and reactive power requirements. All interconnected inverter systems shall comply with the harmonic current limits of IEEE Std 519-1992 (or latest version).
- (d) Battery Energy Storage System. The operating parameters of the BESS for facilities with paired storage shall be as follows:
 - (i) For facilities with variable energy and paired storage: The BESS shall directly charge storage from the variable resource when the Company Active Power Dispatch is for less than the available resource energy.
 - (ii) No more than [] % of the BESS energy capacity can be charged from the grid prior to the fifth (5th) anniversary of the Commercial Operations Date. Thereafter, 100% of the BESS energy capacity can be charged from the grid. **[DRAFTING NOTE: 5-YEAR LIMITATION ON GRID CHARGING WILL BE DELETED IF ITC RECAPTURE IS NOT APPLICABLE TO THE BESS.]**

- (iii) The BESS will not be required to discharge more energy than available relative to the available state of charge.
- (iv) For storage used primarily for energy shifting, the BESS shall be designed for an average annual use of 365 cycle(s) (a cycle is a discharge equal to the portion of the BESS Contract Capacity allocated for energy shifting, and sufficient charging to return the BESS to 100% State of Charge)
- (v) For contingency storage, the BESS storage technology shall be procured based on required charging/discharging duty for the provision of disturbance frequency response. This response will require fast response outside of a specified frequency deadband (settable between 0.1 and 0.5 Hz), in accordance with specified droop and time parameters. **(Historical frequency data for 2 second data resolution samples will be provided to bidders.) (Assumptions and associated restrictions on charging/discharging duty to be supplied by bidders).**

10. **OPERATING COMMITTEE AND OPERATING PROCEDURES.**

Company and Subscriber Organization shall each appoint one representative and one alternate representative to act as the operating committee in matters relating to the Parties' performance obligations under this Contract and to develop operating arrangements for the generation, delivery and receipt of renewable energy from the Facility.

The operating committee may develop mutually agreeable written operating procedures consistent with the requirements of this Contract, to address matters such as day-to-day communications; key personnel; operations-center interface; metering, telemetering, telecommunications, and data acquisition procedures; operations and maintenance scheduling and reporting; reports; operations log; testing procedures; and such other matters as may be mutually agreed upon by the operating committee.

The operating committee shall review the requirements for Active Power Control, the data collection and telemetry, and control system parameters from time to time after the date hereof and may agree on modifications thereto to the extent necessary or convenient for operation of the Facility in accordance with this Contract.

The operating committee shall have authority to act in all technical and day-to-day operational matters relating to performance of this Contract and to attempt to resolve potential disputes, provided, however, that except as explicitly provided herein, the operating committee shall have no authority to amend or waive any provision of this Contract.

--END--

EXHIBIT F-1
DESCRIPTION OF GENERATION AND BATTERY STORAGE FACILITIES

1. Name of Facility:

(a) Location: (TMK No.)

(b) Telephone number (for system emergencies):

(c) E-mail Address:

(d) Contact Information for notices pursuant to the Contract:

Mailing Address:

Address for Delivery by Hand or Overnight Delivery:

Email Address:

2. Owner (If different from Subscriber Organization):

If Subscriber Organization is not the owner, Subscriber Organization shall provide Company with a certified copy of a certificate warranting that the owner is a corporation, partnership or limited liability company in good standing with the Hawai'i Department of Commerce and Consumer Affairs which shall be attached hereto as Exhibit F-1-1 (Good Standing Certificates).

3. Operator:

4. Name of person to whom payments are to be made:

(a) Mailing address:

(b) Hawai'i Gross Excise Tax License number:

5. Equipment:

(a) Type of facility and conversion equipment:

[For example: Small power production facility designated as a Qualifying Facility that produces electric energy using _____.]

(b) Design and capacity

Total Facility Capacity ("Contract Capacity"):

_____ kW

Total Number of Generators:

[number and size of each generator, e.g., one (1) Brand X, 200 kW; one (1) Brand Y, 300 kW]

Description of Equipment:

[For example: Describe the type of energy conversion equipment, capacity, and any special features.]

Individual Unit: **[if more than one generator, list information for each generator]**

	kW	kVAR Consumed	kVAR Produced
<u>Full load</u>			
<u>Startup</u>			

Generator:

Type _____

Rated Power _____ kW

Voltage _____ V, _____ phase

Frequency _____ Hz

Class of Protection _____

Number of Poles _____

Rated Speed _____ rpm

Rated Current _____ A

Rated Power Factor See Exhibit B-2

Batteries

Total Number of Energy Storage Units:

(c) Single or 3 phase:

(d) Name of manufacturer:

(e) Description of Facility SCADA and control system(s)

- (f) The “Allowed Capacity” of this Contract shall be the lower of (i) Contract Capacity or (ii) the net nameplate capacity (net for export) of the Facility installed by the Commercial Operations Date.
- (g) Subscriber Organization may propose revisions to this Section 5 (Equipment) of Exhibit F-1 (Description of Generation Battery and Storage Facilities) (“Section 5”) for Company’s approval prior to commencement of construction, provided, however, that (i) no such revision to this Section 5 shall change the type of Facility or conversion equipment deployed at the Facility from a solar energy conversion facility using photovoltaic equipment; (ii) Subscriber Organization shall be in compliance with all other terms and conditions of this Contract; and (iii) such revision(s) shall not change the characteristics of the Facility equipment or the specifications used in the IRS. Any revision to this Section 5 complying with items (i) through (iii) above shall be subject to Company’s prior approval, which approval shall not be unreasonably withheld. If Subscriber Organization’s proposed revision(s) to this Section 5 otherwise satisfies items (i) and (ii) above but not item (iii) such that Company, in its reasonable discretion, determines that a re-study or revision to all or any part of the IRS is required to accommodate Subscriber Organization’s proposed revision(s), Company may, in its sole and absolute discretion, conditionally approve such revision(s) subject to a satisfactory re-study or revision to the IRS and Subscriber Organization’s payment and continued obligation to be liable and responsible for all costs and expenses of re-studying or revising such portions of the IRS and for modifying and paying for all costs and expenses of modification to the Facility, the Company-Owned Interconnection Facilities based on the results of the re-studies or revisions to the IRS. Any changes made to this Attachment F of the Contract as a result of this Section 5(f) of Exhibit F-1 (Description of Generation and Battery Storage Facilities) shall be reflected in a written amendment to the Contract.

Subscriber Organization understands and acknowledges that Company’s review and approval of Subscriber Organization’s proposed revisions to this Section 5 and any necessary re-studies or revisions to the IRS shall be subject to Company’s then-existing time and personnel constraints. Company agrees to use commercially reasonable efforts, under such time and personnel constraints, to complete any necessary reviews, approvals and/or re-studies or revisions to the IRS.

Any delay in completing, or failure by Subscriber Organization to meet, the Commercial Operations Date as a result of any revisions pursuant to this Section 5 by Subscriber Organization (whether requiring a re-study or revision to the IRS or not) shall be borne entirely by Subscriber Organization and Company shall not be responsible or liable for any delay or failure to meet the Commercial Operations Date by Subscriber Organization.

(h) Insurance carrier(s): **[SUBSCRIBER ORGANIZATION TO PROVIDE INFORMATION]**

6. If Subscriber Organization is not the operator, Subscriber Organization shall provide a copy of the agreement between Subscriber Organization and the operator which requires the operator to operate the Facility and which establishes the scope of operations by the operator and the respective rights of Subscriber Organization and the operator with respect to the sale of electric energy from Facility no later than the Commercial Operations Date. In addition, Subscriber Organization shall provide a certified copy of a certificate warranting that the operator is a corporation, partnership or limited liability company in good standing with the Hawai‘i Department of Commerce and Consumer Affairs no later than the Commercial Operations Date.
7. Subscriber Organization shall provide a certified copy of a certificate warranting that Subscriber Organization is a corporation, partnership or limited liability company in good standing with the Hawai‘i Department of Commerce and Consumer Affairs which shall be attached hereto as Exhibit F-1-1 (Good Standing Certificates).

8. Subscriber Organization, owner and operator shall provide Company a certificate and/or description of their ownership structures which shall be attached hereto as Exhibit F-1-2 (Ownership Structure).
9. In the event of a change in ownership or identity of Subscriber Organization, owner or operator, such entity shall provide within 30 Days thereof, a certified copy of a new certificate and a revised ownership structure.

--END--

**EXHIBIT F-2
CONSULTANTS LIST**

EXHIBIT F-3
MODELING REQUIREMENTS

1. Steady State and Dynamic Model Requirements and As-built Data to be provided by Subscriber Organization. The expected steady state power flow and dynamic models will be provided by the Subscriber Organization during the interconnection study process in the format compatible with the analytical tools used by Company. Depending upon Facility design, different representations may be required for steady state and dynamic simulations. Subscriber Organization will work with Company to derive a complex equivalent model if it is required to meet interconnection study needs. The as-built data and models will be provided by Subscriber Organization immediately upon commissioning with sufficient information to demonstrate that the as-built parameters match the model. Any changes to plant settings that affect its response and impact to the Company System are required to be studied prior to those changes taking effect. The modeling will include all necessary control settings such that the correct capabilities, flags, and settings can be represented in a base case. Where such parameters are settable according to this Contract, the initial models will be configured with parameters mutually agreed with Company for the interconnection study analysis. This includes, but is not limited to:
 - Plant Type: A description of the resource type (e.g., storage, solar PV or wind power resource) used as a flag to ensure that the inverter-based resource is accurately represented in the base case, where applicable.
 - Active and Reactive Capability: The overall plant “composite capability curve” shall be provided by Subscriber Organization for performance purposes. That same curve will be used for accurately modeling the P-Q capability in power flow studies.
 - Plant-Level Voltage Control Settings: Information on the plant voltage control mode to ensure correct voltage control flags and set points are set accordingly in the software tools.
 - The voltage control set point at the POI is provided by the Company. Subscriber Organization shall provide a description of the coordination of any plant-level shunt compensation (static or dynamic) to ensure it can be accurately represented in the power flow base case.The models provided by Subscriber Organization should accurately reflect the contractual requirements established under this Contract.
2. Positive Sequence Stability Modeling. Subscriber Organization shall provide a positive sequence stability model representation which provides sufficient detailed modeling for necessary reliability studies, as specified by Company. **[Note – language to be revised based on proposed Facility.]** For example, the following are typical requirements for plants with inverter equipment:
 - Inverter-Level Controller Model: This represents the overall control of the inverter as an energy or generating resource.
 - Electrical Control Model: This represents the detailed electrical controls of the resource, including large disturbance behavior.
 - Plant-Level Controller Model: This represents control of multiple individual inverters and/or generators within the plant.
3. Short Circuit Modeling. Subscriber Organization will provide appropriate and accurate models to Company to support short circuit studies. **[Company to specify requirements based on specific Facility]**
4. Electromagnetic Transient Modeling. Company will require an electromagnetic transient (“EMT”) model for the Facility. Subscriber Organization shall provide Company with an EMT model for the IRS and an updated EMT model after the Facility has been commissioned. These models are in addition to the positive sequence stability models required for interconnection-wide modeling purposes. In addition, Subscriber Organization shall provide Company with evidence that the expected (and commissioned) EMT model reasonably matches the positive sequence dynamic models provided. This should include a benchmarking report provided by the inverter OEM.

EXHIBIT F-4
GENERATOR AND ENERGY STORAGE CAPABILITY CURVE(S)

EXHIBIT F-5
SINGLE-LINE DRAWING AND INTERFACE BLOCK DIAGRAM

(To be attached as per Section 1(a) of Attachment F)

EXHIBIT F-6
RELAY LIST AND TRIP SCHEME

(To be attached as per Section 1(a) of Attachment F.)

EXHIBIT F-7
CONTROL SYSTEM ACCEPTANCE TEST CRITERIA

[THIS ATTACHMENT WILL NEED TO BE MODIFIED BASED ON THE RESULTS OF THE IRS]

1. The Control System Acceptance Test for the Facility will be conducted, following installation of the Facility. The Control System Acceptance Test procedures will be in accordance with criteria set forth herein. The Control System Acceptance Test shall be performed in accordance with Good Engineering and Operating Practices and demonstrate to Company's satisfaction that the Facility and the interconnection portion of the Facility, including Company-Owned Interconnection Facilities, have met the provisions of Section 5. (Company Dispatch) of the Contract and Section 3 (Performance Standards) of Attachment F (Facility Owned by Subscriber Organization).
 1. Control System Acceptance Test procedures will be developed by Company for the Subscriber Organization's review at least sixty (60) Days in advance of performing the tests based on the date provided by Company.
 2. The procedures will include, but not be limited to, demonstration of the functional requirements of the Facility defined in Section 5. (Company Dispatch) of the Contract and Section 3 (Performance Standards) of Attachment F (Facility Owned by Subscriber Organization) such as, but not limited to:
 1. Interconnection equipment and communications to support remote monitoring of the Facility and control of Facility breakers
 2. Droop characteristic and change of frequency control / response modes (if applicable)
 3. Real power delivery under remote Company Dispatch, Active Power Dispatch. For facilities with directly controlled storage, the storage will be operated to perform at least two full charging/discharging cycles.
 4. Accurate provision of limits for Minimum and Maximum Dispatch (Power Possible, Minimum load capability)
 5. Ramp rates for controlled actions
 6. Control of Facility breakers
 7. Voltage regulation
 8. Grid forming and Black start (if applicable)
 9. BESS Capacity Test and demonstration of the round-trip efficiency of the BESS, each as described in Attachment H (BESS Requirements)
 3. Testing of primary and redundant communications between Company System Operator and Facility Operator
 4. The actual dynamic response of the Facility equipment will be confirmed to allow Company transient stability model to reflect the as-left conditions of the unit. During the commissioning, the following will be required:
 1. A final review by Company engineers of the equipment installed to control the operation and protect the plant will be needed upon installation and prior to the start of commercial operation.
 2. The review will include off-line tuning and testing results of the excitation and governor control and/or control system and the IEEE block diagram utilized for the PSS/E dynamics program.
 3. iii. During the commissioning of the actual Facility, equipment system testing will be conducted to ensure that similar, well damped, expected responses will be produced by the facility. The as-left parameters obtained from real and reactive local response tuning will be determined for use in the Company planning model. The Subscriber Organization will

- provide an estimate of the earliest date for the Control System Acceptance Test at least ninety (90) Days before the date.
5. The Control System Acceptance Test procedures for the Facility will be mutually agreed upon between Subscriber Organization and Company prior to conducting the test.
 6. When the Facility is ready for the Control System Acceptance Test, Subscriber Organization shall notify Company at least seven (7) Days prior to the test and shall coordinate with Company. Subscriber Organization shall perform, and Company shall monitor such test no earlier than seven (7) Days from Company's receipt of such notice.
 7. The Control System Acceptance Test is to be successfully completed prior to the Commercial Operation Date
2. Examples of the type of tests conducted to meet the aforementioned objectives may include, but are not limited to the following:
1. On-site Tests
 1. SCADA Test to verify the status and analog telemetry, and if the remote controls between the Company's EMS and the Facility are working properly end-to-end.
 2. Dispatch Test to verify if the Facility's active power limit controls and the Active Power Control Interface with the Company's EMS are working properly. The Test is generally conducted by setting different active power setpoints and limits and observing the proper dispatch at the appropriate ramp rate limiting of the Facility's real power output.
 2. Control Test for Voltage Regulation to verify the Facility can properly perform automatic voltage regulation as defined in this Exhibit F-7 and pursuant to Attachment F and the Contract. Test is generally conducted by making small adjustments of the voltage setpoint and verifying by observation that the Facility regulates the voltage at the point of regulation to the setpoint by delivering/receiving reactive power to/from the Company System to maintain the applicable setpoint according to the reactive power control and the reactive amount requirements of Sections 3(a) (Reactive Power Control) and Section 3(b) (Reactive Power Characteristics) of Attachment F (Facility Owned by Subscriber Organization) to the Contract. **[Note: Sub transmission Requirements]**
 3. Frequency Response Test to verify the Facility provides a frequency droop response as defined in the Contract. Test is generally conducted by adjusting of the frequency reference setting and verifying by observation that the Facility responds per droop and deadband settings, and appropriately modifies the Company issued Dispatch Setpoint. If different modes of frequency response are provided, each mode is tested (i.e.; isochronous, fast frequency response, active power droop response).
 4. Loss-of-Communication Test to verify the Facility will properly shutdown upon the failure of the direct-transfer-trip communication system. Test is generally conducted by simulating a communications failure and observing the proper shutdown of the Facility. [If DTT required for the Project]
 5. Round trip efficiency test, as described in Attachment H (BESS Requirements) Section 1. (BESS Tests) to verify that the round-trip efficiency of the BESS is not less than [] percent ([]%). **[DRAFTING NOTE: The round-trip efficiency percentage will be taken from Subscriber Organization's response to the RFP.]**
 6. BESS Capacity Test to verify the BESS Capacity Ratio.
 1. Monitoring Test:
 - a. The monitoring test requires the Facility to operate as it would in normal operations.
 - b. To ensure useful and valid test data is collected for variable facilities, the monitoring test shall end when one of the following criteria is met:
 - i. For variable energy resources, Facility's gross power production is greater than 85% of its Allowed Capacity, for at least four (4) hours in any continuous 24-hour CSAT period.

- ii. For solar facilities, the recorded renewable energy resource at the Facility is above 600 W/m² for least eight (8) hours in any continuous 48-hour CSAT period.
 - iii. For wind facilities, the recorded wind speed is sufficient for turbines to operate for at least 8 hours in any continuous 48-hour CSAT period
14 continuous Days from the start of the CSAT.
7. At the end of the test, an evaluation period is selected based on the criteria that triggered the end of the test.
8. The performance of the Facility during the period of the successfully completed monitoring test is evaluated for, e.g., voltage regulation, frequency response, dispatch control, operating limits and ramp rate performance, to verify the performance meets the requirements of this Exhibit F-7. According to the criteria set forth in the testing procedures. Certain requirements, such as disturbance ride-through requirements, cannot be adequately tested without actual grid disturbances. These requirements will be confirmed following a grid event based on operational data, which may be after the completion of the Control System Acceptance Test. The Parties understand and agree that a successful completion of the test does not constitute a waiver of any of the performance standards of Subscriber Organization, all of which are hereby reserved, and shall not alleviate Subscriber Organization from any of its obligations under the Contract, in particular, as required in Section 5. (Company Dispatch) and the Performance Standards in Section 3. (Performance Standards) of Attachment F (Facility Owned by Subscriber Organization).

---END---

EXHIBIT F-8
ACCEPTANCE TEST GENERAL CRITERIA

**[THIS ATTACHMENT WILL NEED TO BE MODIFIED
BASED ON THE RESULTS OF THE IRS]**

Upon final completion of Company review of the Facility's drawings, final test criteria and procedures shall be agreed upon by Company and Subscriber Organization no later than thirty (30) Days prior to conducting the Acceptance Test in accordance with the Contract. The Acceptance Test shall include, but not be limited to, the following:

1. Interconnection.
 - (A) A visual inspection of all Interconnection equipment and verification of as-built drawings.
 - (B) Phase rotation testing to verify proper phase connections.
 - (C) Based on manufacturer's specification, test the local operation of the Facility's generator breaker(s) and inter-tie breaker(s), and other breaker(s) which connect the Facility equipment to Company System – must open and close locally using the local controls remotely from Company's EMS. Test and ensure that the status shown on the EMS is the same as the actual physical status in the field.
 - (D) Relay test engineers to connect equipment and simulate certain inputs to test and ensure that the protection schemes such as any under/over frequency and under/over voltage protection or the Direct Transfer Trip operate as designed. (For example, a fault condition may be simulated to confirm that the breaker opens to sufficiently clear the fault. Additional scenarios may be tested and would be outlined in the final test criteria and procedures.) Subscriber Organization to also test the synchronizing mechanisms to which the Facility would be synchronizing and closing into the Company System to ensure correct operation. Other relaying also to be tested as specified in the protection review of the IRS and on the single line diagram, Attachment E (Single-Line Drawing and Interface Block Diagram) for the Facility.
 - (E) All breaker disconnects and other high voltage switches will be inspected to ensure they are properly aligned and operated manually or automatically (if designed).
 - (F) Step-Up Transformer Enclosure(s) inspections – The Step-Up Transformer Enclosure(s) may be inspected to test and ensure that the equipment that Subscriber Organization has installed is installed and operating correctly based upon agreed to design. Wiring may be field verified on a sample basis against the wiring diagrams to ensure that the installed equipment is wired properly. The grounding mat at the Step-Up Transformer Enclosure(s) may be tested to make sure there is adequate grounding of equipment.

- (G) Communication testing – Communication System testing to occur to ensure correct operation. Detailed scope of testing will be agreed by Company and Subscriber Organization to reflect installed systems and communication paths that tie the Facility to Company’s communications system.
- (H) Various contingency scenarios to be tested to ensure adequate operation, including testing contingencies such as loss of communications, and fault simulations to ensure that the Facility’s breakers, if any, open as they are designed to open. (Back up relay testing)
- (I) Metering section inspection; verification of metering PTs, CTs, and cabinet and the installation of the two Company meters.

2. Telephone Communication.

- (A) Test to confirm Company has a direct line to the Facility control room at all times and that it is programmed correctly.
- (B) Test to confirm that the Facility operators can sufficiently reach Company System Operator.
- (C) Verification of dial-up telephone connection for metering cabinet.

3. Drawings, Documentation and Equipment Warranties.

The items below are required components of the Acceptance Test and must be satisfied for successful completion of this Test.

- (A) Electronic and three (3) hard copies of all Switchyard construction drawings, specifications, calibrations, and settings including as-built drawings.
- (B) Equipment operating and maintenance manuals, spare parts lists, commissioning notes, as-built equipment settings, and other information related to the switchyard equipment.
- (C) Contractor construction warranties and equipment warranties.
- (D) Phase rotation testing to verify proper phase connections.
- (E) Switching Station inspections – The Switching Station may be inspected to test and ensure that the equipment that Subscriber Organization has installed is installed and operating correctly based upon agreed-to design. Wiring may be field verified on a sample basis against the wiring diagrams to ensure that the installed equipment is wired properly. The grounding mat at the Switching Station may be tested to make sure there is adequate grounding of equipment.
- (F) If agreed by the Parties in writing, some requirements may be postponed to the Control Systems Acceptance Test.

ATTACHMENT G

COMPANY-OWNED INTERCONNECTION FACILITIES

(To be filled out by Company)

1. DESCRIPTION OF COMPANY-OWNED INTERCONNECTION FACILITIES.

- (a) General. Company will furnish or construct, own, operate and maintain all interconnection facilities required to interconnect the Company's system with the CBRE Facility at ___volts, up to the point of interconnection.
- (b) Site. Where any Company-Owned Interconnection Facilities are to be located on the Site, Subscriber Organization shall provide, at no expense to Company, a location and access acceptable to Company for all such Company-Owned Interconnection Facilities, as well as an easement, license or right of entry to access such Company-Owned Interconnection Facilities. If power sources (120/240VAC) are required, Subscriber Organization shall provide such sources, at no expense to Company.
- (c) IRS. If an IRS addressing Facility requirements was or will be completed for the Project in accordance with the IRS Letter Agreements, the results have been or will be incorporated in Attachment F (Facility Owned by Subscriber Organization) and this Attachment G (Company-Owned Interconnection Facilities) as appropriate
- (d) The Company-Owned Interconnection Facilities, for which the Subscriber Organization agrees to pay, include: [**Need to specify the interconnection facilities. If no interconnection facilities, state "None".**]
- (e) Responsibility of Subscriber Organization and Company. The general responsibilities of Subscriber Organization and Company for the design, procurement, installation, programming/testing, and maintenance/ownership of equipment at the Facility and the Company Owned Interconnection Facilities is specified in Matrix G-1 (Substation Responsibilities) and Matrix G-2 (Telecom Responsibilities).

2. Construction and Support Services By Subscriber Organization.

(a) Construction and Support Services By Subscriber Organization.

Subscriber Organization (and/or its third party consultants or contractors (collectively, "Contractors")) will design, engineer, construct, test and place in service, at Subscriber Organization's expense the items identified in Matrix G-1 (Substation Responsibilities) and Matrix G-2 (Telecom Responsibilities) as being the responsibility of Subscriber Organization to construct

All design, engineering and construction performed by Subscriber Organization (and/or its Contractors) shall, without limitation, satisfy the wind load and seismic load requirements of the International Building Code and any more stringent requirements imposed under applicable Laws.

- (i) Subscriber Organization shall provide the necessary support for the Company's [redacted] kV overhead line extension work, which may include, but not limited to:

- A. Furnish surveyed topographical drawing including contour lines of project areas and beyond as needed in State Plane coordinates with overlay of the Facility and Company pole line route(s) indicating pole locations and anchors in CADD format acceptable to Company.
 - B. Staking of Company proposed poles and anchors by surveyor.
 - C. Graded access roads including gravel if required by Company to provide sufficient vehicle access to Company poles and anchors by Company trucks and cranes.
 - D. Graded level pads to provide vehicle working areas around all Company poles and anchors.
 - E. Grading of the areas beneath the Company's overhead lines as needed to provide required ground clearance.
 - F. Grubbing and clearing of vegetation within Company's easement area or as required.
- (b) Coordination of Construction. Prior to Subscriber Organization engaging the Contractors, Subscriber Organization shall obtain Company's written approval, which approval shall not be unreasonably withheld. Prior to Subscriber Organization and/or its Contractors first starting to work on the construction plans for Company-Owned Interconnection Facilities to be constructed by Subscriber Organization (and/or its Contractors), such as the civil, structural, and construction drawings, specifications to vendors, vendor approved final drawings and materials lists (collectively, the "Plans"), Subscriber Organization and/or its Contractors shall meet with Company to discuss the construction of such Company-Owned Interconnection Facilities, including but not limited to subjects concerning coordination of construction milestone dates, agreement on areas of interface design, and Company's design/drawing layout and symbols standards, equipment specifications and construction specifications and standards. Company will provide the equipment specifications and construction specifications and standards information so Subscriber Organization can incorporate such information in its bid documents.
- (c) Plans. Subscriber Organization shall provide Company its complete Plans at 30%, 60% and 90% completion. No later than sixty (60) Days before Subscriber Organization and/or its Contractors first start to order materials and equipment for Company-Owned Interconnection Facilities to be constructed by Subscriber Organization and/or its Contractors, Subscriber Organization shall provide Company with the final Plans. The Plans for Company-Owned Interconnection Facilities to be constructed by Subscriber Organization (and/or its Contractors) shall comply with (i) all applicable Laws; (ii) Company's design/drawing layout and symbol standards, equipment specifications, and construction specifications and standards; and (iii) Good Engineering and Operating Practices (collectively, the "Standards"). Subscriber Organization shall submit design drawings in MicroStation format per Company standards.
- (d) Company's Review of the Plans. Unless otherwise agreed to by the Parties, Company shall have thirty (30) Days following receipt of the complete Plans at each stage (30%, 60%, 90% and final) for it to review and comment on the Plans, and verify in writing to Subscriber Organization that the Plans comply with the Standards, which verification shall

not be unreasonably withheld. If Company reasonably determines that the Plans are not in accordance with the Standards, then it may request in writing a response from Subscriber Organization to its comments and Subscriber Organization shall respond in writing within thirty (30) Days of such request by providing (i) its justification for why its Plans conform to the Standards or (ii) changes in the Plans responsive to Company's comments and in accordance with the Standards.

- (e) Company Inspection. Construction work will be subject to Company inspections to ensure that construction is done in accordance with the Standards. Company inspectors will be allowed access to the construction sites for inspections and to monitor construction work. The inspector shall have the authority to work with the appropriate construction supervisor to stop any work that does not meet the Standards. All equipment and materials used in Company-Owned Interconnection Facilities to be constructed by Subscriber Organization and/or its Contractors shall meet the Standards.
- (f) Acceptance Test Procedures.
- (i) Subscriber Organization acknowledges that: (aa) Company has multiple on-going projects with other developers as well as its own capital improvement projects; (bb) Company has limited resources to provide engineering oversight (such as review of plans) to such projects and to participate in the testing of such projects; (cc) in order for Company to accommodate such oversight and testing, it is necessary for Company to sequentially allocate its resources for each project a year or more in advance; (dd) the result is a queue of such projects that reflects the scheduling commitments of Company's resources to conduct such oversight and to participate in such testing; (ee) if a project is behind the schedule on which Company's resources have been scheduled for the oversight of such project, or if a project is not ready for testing at the time Company's resources have been scheduled for the testing of such project, or if a project does not complete testing within the period for which Company's resources have been scheduled for such testing, the progress of projects later in the queue may be adversely affected; and (ff) the Project will lose its place in the queue and will be assigned a new Acceptance Testing date for commencement of the Acceptance Test that will be behind the other projects then in the queue if (i) the Subscriber Organization fails to satisfy any of the conditions precedent set forth in Section 2(f)(ii) of this Attachment G (Company-Owned Interconnection Facilities) within the time period specified therein for the task in question, (ii) the Acceptance Test are not satisfactorily completed within the time allotted to complete such testing.
- (ii) The Conduct of the Acceptance Test is subject to the satisfaction of the following conditions precedent within the time period required by Company for the task in question:
- Final Single-Line Drawing, and notes, has received Company's written consent pursuant to Section 1(a)(i) (Single-Line Drawing, Interface Block Diagram, Relay List, Relay Settings and Trip Scheme) of Attachment F (Facility Owned by Subscriber Organization) to this Contract.
 - Final Relay List and Trip Scheme have received Company's written consent pursuant to Section 1(a)(i) (Single-Line Drawing, Interface Block Diagram, Relay List, Relay Settings and Trip Scheme) of Attachment F (Facility Owned by Subscriber Organization) to this Contract.

- Final Interface Block Diagram has received Company consent pursuant to Section 1(a)(i) (Single-Line Drawing, Interface Block Diagram, Relay List, Relay Settings and Trip Scheme) of Attachment F (Facility Owned by Subscriber Organization) to this Contract.
- Final Control System Telemetry and Control List has received Company consent.
- Final phasor measurement unit (PMU) devices, if applicable, have received Company consent.
- Control system design and tunable parameters reviewed and mutually agreed upon as needed to meet the Company requirements in accordance with Attachment F (Facility Owned by Subscriber Organization) Performance Standards.
- Agreement on Active Power Control Interface.
- No later than 14 Days prior to commencement of the Acceptance Test:
 - Subscriber Organization shall have certified to Company that Subscriber Organization-Owned Interconnection Facilities have been installed and commissioned and such certification has not, prior to the commencement of the Acceptance Test, been subsequently challenged by Company on the basis of on-site observations made by the Company's representatives following the walk-through to be conducted pursuant to Section 2(f)(iii) of this Attachment G (Company-Owned Interconnection Facilities).
 - Subscriber Organization shall have certified to Company that any Company-Owned Interconnection Facilities built by Subscriber Organization (and/or its Contractors) have been installed and commissioned and such certification has not, prior to the commencement of the Acceptance Test, been subsequently challenged by Company on the basis of on-site observations made by the Company's representatives following the walk-through to be conducted pursuant to Section 2(f)(iii) of this Attachment G (Company-Owned Interconnection Facilities).
- Any Company-Owned Interconnection Facilities not built by or on behalf of Subscriber Organization have been installed and commissioned.
- No later than 7 Days prior to the commencement of the Acceptance Test, Subscriber Organization and Company shall have participated in walk-through of fully constructed Interconnection Facilities.
- Redlined as-built drawings of the Subscriber Organization-Owned Interconnection Facilities and any of the Company-Owned Interconnection Facilities built by Subscriber Organization (and/or its Contractors) shall have been provided to Company.
- Continuous power is being supplied to Company's protection and SCADA equipment.
- Not less than four (4) weeks prior to the commencement of the Acceptance Test, the high speed communication lines required under this Contract have been commissioned and are ready for use.

- Not less than two (2) weeks prior to the commencement of the Acceptance Test, Subscriber Organization and Company have participated in an on-Site Acceptance Test coordination meeting.
- (iii) Subscriber Organization shall provide Company with at least fourteen (14) Days advance written notice of the commencement of the Acceptance Test. The Acceptance Test will be conducted on Business Days during normal business hours and may take a minimum of 30 Days to complete. No electric energy will be delivered from Subscriber Organization to Company during the Acceptance Test. No later than thirty (30) Days prior to conducting the Acceptance Test, Company and Subscriber Organization shall agree on a written protocol setting out the detailed procedure and criteria for passing the Acceptance Test. At the time that Subscriber Organization provides its 14-Day notice of the Acceptance Test to Company, Subscriber Organization shall concurrently schedule a site walk-through of the Facility with Company to occur no later than seven (7) Days prior to the Acceptance Test. Subscriber Organization's 14-Day notice to Company of the Acceptance Test shall constitute its certification that (i) the completion of the installation and commissioning of the Subscriber Organization-Owned Interconnection Facilities and the Company-Owned Interconnection Facilities built by Subscriber Organization (and/or its Contractors) and (ii) a walk-through by Company shall demonstrate, to Company's reasonable satisfaction, Subscriber Organization's readiness to commence with the Acceptance Test. If, after the site walk-through, Company representatives reasonably determine that Subscriber Organization is not ready to commence with the Acceptance Test, the Project will lose its place in the queue and will be assigned a new Acceptance Testing date that will be behind the other projects then in the queue. In the meantime, Subscriber Organization shall remediate the deficiencies identified by Company, and the process described in this Section 2(f) (Acceptance Test Procedures) of this Attachment G (Company-Owned Interconnection Facilities), shall commence again until Subscriber Organization's readiness for the Acceptance Test is demonstrated to Company's reasonable satisfaction. Successful completion of the Acceptance Test requires successful completion of each of the individual tests that comprise the Acceptance Test. Retesting of any individual test constitutes as restart of the Acceptance Test if such retesting is required because of a prior failure of such individual test or because of a prior test could not be completed because of a problem with the Facility. Within fifteen (15) Business Days of completion of the Acceptance Test and Company's receipt of the final report setting forth the results of the Acceptance Test, Company shall notify Subscriber Organization in writing whether the Acceptance Test has been passed and, if so, the date upon which the Acceptance Test was passed.
- (iv) Company will be present when the Acceptance Test is conducted, and Subscriber Organization shall promptly correct any deficiencies identified during the Acceptance Test. Subscriber Organization will be responsible for the cost of Company personnel (and/or Company contractors) performing the duties (such as reviewing the Plans and reviewing the construction) necessary for Company-Owned Interconnection Facilities to be constructed by Subscriber Organization (and/or its Contractors). If Company (i) does not make any inspection or test, (ii) does not discover defective workmanship, materials or equipment, or (iii) accepts Company-Owned Interconnection Facilities (that were constructed by Subscriber Organization and or its Contractors), such action or inaction shall not relieve Subscriber Organization from its obligation to do and complete the work in accordance with the Plans approved by Company.

- (g) As-Built Drawings. Within thirty (30) Days of the successful completion of the Acceptance Test, Subscriber Organization shall provide for Company review a set of the proposed as-built drawings for the Company-Owned Interconnection Facilities constructed by Subscriber Organization (and/or its Contractors). Within thirty (30) Days of Company’s receipt of the proposed as-built drawings, Company shall provide Subscriber Organization with either (i) its comments on the proposed as-built drawings or (ii) notice of acceptance of the proposed as-built drawings as final as-built drawings. If Company provides comments on the proposed as-built drawings, Subscriber Organization shall incorporate such comments into a final set of as-built drawings and provide such final as-built drawings to Company within twenty (20) Days of Subscriber Organization’s receipt of Company’s comments

3. SUBSCRIBER ORGANIZATION PAYMENT TO COMPANY FOR COMPANY-OWNED INTERCONNECTION FACILITIES, REVIEW OF GENERATING FACILITY, AND REVIEW OF VERIFICATION TESTING.

- (a) Subscriber Organization shall pay to the Company the total estimated interconnection costs to be incurred by the Company (Total Estimated Interconnection Costs), which is comprised of (i) the estimated cost of the Company-Owned Interconnection Facilities, (ii) the estimated engineering costs associated with a) developing the Company-Owned Interconnection Facilities and b) reviewing and specifying those portions of the CBRE Facility which allow interconnected operation, and iii) witnessing and reviewing the verification testing, which shall include testing of the telemetry and control interface which allows the Company to remotely measure, monitor, evaluate and verify technical compliance, CBRE Facility performance, and power quality and, if necessary, control the Generating Facility. The following summarizes the Total Estimated Interconnection Costs:

Description	Estimated Cost (\$) [If no cost, state “None”.]
Total Estimated Interconnection Costs (\$):	

- (b) The Total Estimated Interconnection Cost, which, except as otherwise provided herein, is non- refundable, shall be paid by the Subscriber Organization fourteen (14) days after receipt of an invoice from the Company, which shall be provided not less than thirty (30) days prior to start of procurement of the Company-Owned Interconnection Facilities.

(c) Within thirty (30) days of receipt of an invoice, which shall be provided within fourteen (14) days of the final accounting, which shall take place within sixty (60) days of completion of construction of the Company-Owned Interconnection Facilities, the Subscriber Organization shall remit to the Company the difference between the Total Estimated Interconnection Costs paid to date and the total actual interconnection cost (Total Actual Interconnection Costs). The latter is comprised of (i) the total costs of the Company-Owned Interconnection Facilities, and (ii) the total engineering costs associated with a) developing the Company-Owned Interconnection Facilities and b) reviewing and specifying those portions of the Generating Facility which allow interconnected operations as such are described in Exhibit F-1, and iii) reviewing the verification testing. If in fact the Total Actual Interconnection Costs is less than the payments received by the Company as the Total Estimated Interconnection Costs, the Company shall repay the difference to the Subscriber Organization within thirty (30) days of the final accounting. If the Contract is terminated prior to the Subscriber Organization's payment for the Total Actual Interconnection Costs (or the portion of this cost which has been incurred) or prior to the Company's repayment of the over collected amount of the Total Estimated Interconnection Costs (or the portion of this cost which has been paid), such payments shall be made by the Subscriber Organization or Company, as appropriate. If payment is due to the Company, the Subscriber Organization shall pay within thirty (30) days of receipt of an invoice, which shall be provided within fourteen (14) days of the final accounting, which shall take place within sixty (60) days of the date the Contract is terminated. If payment is due to the Subscriber Organization, the Company shall pay within thirty (30) days of the final accounting.

(d) All Company-Owned Interconnection Facilities shall be the property of the Company.

4. OPERATION, MAINTENANCE AND TESTING COSTS.

The Company will bill the Subscriber Organization monthly and the Subscriber Organization will, within 30 days after the billing date, reimburse the Company for any costs incurred in operating, maintaining or testing the Company-Owned Interconnection Facilities. The Company's costs will be determined on the basis of outside service costs, direct labor costs, material costs, transportation costs, applicable overheads at time incurred and applicable taxes. Applicable overheads will include such costs as vacation, payroll taxes, non-productive wages, supervision, tools expense, employee benefits, engineering administration, corporate administration, and materials handling. Applicable taxes will include the Public Service Company Tax, and Public Utility Fee and Hawai'i general excise tax

5. RELOCATION OF COMPANY-OWNED INTERCONNECTION FACILITIES.

(a) In the event that the Land Rights include a relocation clause and such clause is exercised or if Company-Owned Interconnection Facilities must be relocated for any other reason not caused by Company, Subscriber Organization shall bear the cost of such relocation. Prior to the relocation of the Company-Owned Interconnection Facilities Company shall invoice Subscriber Organization for the total estimated cost of relocating the Company-Owned Interconnection Facilities (the "Total Estimated Relocation Cost"). Subscriber Organization shall, within thirty (30) Days after the invoice date, pay to Company the Total Estimated Relocation Cost.

(b) Once the relocation of the Company-Owned Interconnection Facilities is complete, Company shall conduct a final accounting of all costs related thereto. Within thirty (30)

Days of the final accounting, which shall take place within one hundred and twenty (120) Days of completion of the relocation of Company-Owned Interconnection Facilities, Subscriber Organization shall remit to Company the difference between the Estimated Relocation Cost paid to date and the total actual relocation cost incurred by Company (the “Total Actual Relocation Cost”). If the Total Actual Relocation Cost is less than the payments received by Company as the Total Estimated Relocation Cost, Company shall repay the difference to Subscriber Organization within thirty (30) Days of the final accounting.

6. LAND RESTORATION

- (a) Definition of “Land”. For the purposes of this Attachment G (Company-Owned Interconnection Facilities), “Land” means any portion of the Site and any other real property where any Company-Owned Interconnection Facilities are located.
- (b) Removal of Interconnection Facilities. After termination of this Contract, if requested by Company, Subscriber Organization shall, at its sole cost and expense, remove (i) the Company-Owned Interconnection Facilities from the Land and (ii) the Subscriber Organization-Owned Interconnection Facilities from the Land, and, in conjunction with such removal, shall develop and implement a program to recycle, to the fullest extent possible, or to otherwise properly dispose of, all such removed infrastructure; provided, however, that, Company may elect to remove all or part of the Company-Owned Interconnection Facilities and/or Subscriber Organization-Owned Interconnection Facilities from the Land because of operational concerns over the removal of such Interconnection Facilities, in which case Subscriber Organization shall reimburse Company for its costs to remove such Company-Owned Interconnection Facilities and/or Subscriber Organization-Owned Interconnection Facilities. To the extent Subscriber Organization is obligated to remove Company-Owned Interconnection Facilities and/or Subscriber Organization-Owned Interconnection Facilities, Subscriber Organization shall complete such removal within ninety (90) Days of termination of this Contract, or as otherwise agreed to by both Parties in writing.
- (c) Restoration of the Land. After the termination of this Contract and removal of the Company-Owned Interconnection Facilities and/or Subscriber Organization-Owned Interconnection Facilities, as the case may be, Subscriber Organization shall, at its sole cost and expense, restore the Land to its condition prior to construction of such Company-Owned Interconnection Facilities and/or Subscriber Organization-Owned Interconnection Facilities, as applicable. Land restoration shall be completed within ninety (90) Days of termination of this Contract, or as otherwise agreed to by both Parties in writing.

7. TRANSFER OF OWNERSHIP/TITLE

- (a) Transfer of Ownership and Title. On the Transfer Date, Subscriber Organization shall transfer to Company all right, title and interest in and to Company-Owned Interconnection Facilities to the extent such facilities were designed and constructed by Subscriber Organization and/or its Contractors together with (i) all applicable manufacturers’ or Contractors’ warranties which are assignable and (ii) all Land Rights necessary to own, operate and maintain Company-Owned Interconnection Facilities on and after the Transfer Date. Subscriber Organization shall provide a written list of the manufacturers’ and

Contractors' warranties which will be assigned to Company and the expiration dates of such warranties no later than thirty (30) Days before the Transfer Date.

- (b) No Liens or Encumbrances. Company's title to and ownership of Company-Owned Interconnection Facilities that were designed and constructed by Subscriber Organization and/or its Contractors shall be free and clear of liens and encumbrances.
- (c) Form of Documents. The transfers to be made to Company shall not require any further payment by Company. The form of the document to be used to convey title to the Company-Owned Interconnection Facilities that were designed and constructed by or on behalf of Subscriber Organization shall be in the form set forth by Company. The form of the document(s) to be used to assign leases shall be substantially in the form set forth by Company.

8. GOVERNMENTAL APPROVALS FOR ANY COMPANY-OWNED INTERCONNECTION FACILITIES.

For all other Governmental Approvals for Company-Owned Interconnection Facilities, Subscriber Organization shall provide these prior to the Transfer Date. On or before the Transfer Date, Subscriber Organization shall provide Company with (i) copies of all such Governmental Approvals obtained by Subscriber Organization regarding the construction, ownership, operation and maintenance of Company-Owned Interconnection Facilities that Subscriber Organization and/or its Contractors constructed and (ii) documentation regarding the satisfaction of any condition or requirement set forth in any Governmental Approvals for Company-Owned Interconnection Facilities (excluding on-going reporting or monitoring requirements that may continue beyond the Transfer Date in accordance with such Governmental Approval) or that such Governmental Approvals have otherwise been closed with the issuing Governmental Authority.

9. LAND RIGHTS

Subscriber Organization shall, prior to the commencement of construction of the Company-Owned Interconnection Facilities (whether to be built by Subscriber Organization or by Company) obtain at its sole cost and expense all Land Rights that are required to construct, own, operate and maintain the Company-Owned Interconnection Facilities. Without limitation to the preceding sentence, Subscriber Organization shall pay all surveying and mapping costs, appraisal fees, document preparation fees, recording fees or other costs. Subscriber Organization shall use commercially reasonable efforts to obtain on behalf of the Company perpetual Land Rights for the Company-Owned Interconnection Facilities. Such Land Rights shall contain terms and conditions which are acceptable to Company and the documents setting forth the Land Rights shall be provided in advance of execution to Company for its review and approval and shall be recorded if required by Company. Following the Execution Date, Subscriber Organization shall provide as part of the Monthly Progress Report the status of negotiations with landowner(s) regarding the Land Rights. Notwithstanding the foregoing, Company shall have the right in its sole discretion, at any time upon notice to Subscriber Organization, to communicate directly with the landowner(s) and/or participate in the negotiations with landowner(s) for the Land Rights. For so long as Subscriber Organization has the right under this Contract to sell the availability of the Facility to Company, Subscriber Organization shall pay for any rents and other payments due under such Land Rights that are associated with Company-Owned Interconnection Facilities.

10. CONTRACTS FOR COMPANY-OWNED INTERCONNECTION FACILITIES

For all contracts entered into by or on behalf of Subscriber Organization for Company-Owned Interconnection Facilities to be designed, engineered and constructed, in whole or in part, by or on behalf of Subscriber Organization, the following shall apply: (i) Company shall be made an intended third-party beneficiary of such contracts; and (ii) Company shall be provided with copies of such executed contracts, which may be redacted but only to the extent required to prevent disclosure of confidential or proprietary information of Subscriber Organization or the counterparty to such agreement; provided, however, that such redactions may not conceal information that is necessary for the Company to determine and exercise Company's rights under such contracts as a third-party beneficiary.

EXHIBIT G-1

FORM OF LETTER OF CREDIT

Page 1 of 2

[Bank Letterhead]

[Date]

Beneficiary: [designate appropriate entity according to where Facility is located] **Maui Electric Company, Limited [or] Hawai'i Electric Light Company, Inc.**

[Address]

[Bank's Name]

[Bank's Address]

Re: **[Irrevocable Standby Letter of Credit Number]**

Ladies and Gentlemen:

We hereby establish, in your favor, our irrevocable standby Letter of Credit Number _____ (this "Letter of Credit") for the account of **[Applicant's Name]** and **[Applicant's Address]** in the initial amount of \$ _____ **[dollar value]** and authorize you, Maui Electric Company, Limited **[or]** Hawai'i Electric Light Company, Inc. ("Beneficiary"), to draw at sight on **[Bank's Name]**.

Subject to the terms and conditions hereof, this Letter of Credit secures **[Project Entity Name]**'s certain obligations to Beneficiary under the Mid-Tier Standard Form Contract for Renewable Dispatchable Generation dated as of _____ between **[Project Entity Name]** and Beneficiary.

This Letter of Credit is issued with respect to the following obligations: _____.

This Letter of Credit may be drawn upon under the terms and conditions set forth herein, including any documentation that must be delivered with any drawing request.

Partial draws of this Letter of Credit are permitted. This Letter of Credit is not transferable. Drafts on us at sight shall be accompanied by a Beneficiary's signed statement signed by a representative of Beneficiary as follows:

The undersigned hereby certifies that (i) I am duly authorized to execute this document on behalf of Maui Electric Company, Limited **[or]** Hawai'i Electric Light Company, Inc. and [(ii) the amount of the draft accompanying this certification is due and owing to Maui Electric Company, Limited **[or]** Hawai'i Electric Light Company, Inc. under the terms of the Mid-Tier Standard Form Contract for Renewable Dispatchable Generation dated as of _____, between _____, and Maui Electric Company, Limited **[or]** Hawai'i Electric Light Company, Inc.][(ii) the Letter of Credit will expire in less than thirty (30) days, it has not been replaced or extended and collateral is still required under Section 11.G. 1 of the Mid-Tier Standard Form Contract for Renewable Dispatchable Generation *].

* For draw relating to lapse of Letter of Credit while credit support is still required pursuant to the Mid-Tier Standard Form Contract for Renewable Dispatchable Generation.

Such drafts must bear the clause "Drawn under **[Bank's Name and Letter of Credit Number
_____ and date of Letter of Credit.]**"

All demands for payment shall be made by presentation of originals or copies of documents, by facsimile transmission of documents to **[Bank Fax Number]** or other such number as specified from time to time by the bank, or by email transmission of documents to **[Bank Email Address]** or other such email address as specified from time to time by the bank. If presentation is made by facsimile transmission or an email transmission, you may contact us at **[Bank Phone Number]** to confirm our receipt of the transmission. Your failure to seek such a telephone confirmation does not affect our obligation to honor such a presentation. If presented by facsimile or email, original documents are not required.

This letter of credit shall expire one year from the date hereof. Notwithstanding the foregoing, however, this letter of credit shall be automatically extended (without amendment of any other term and without the need for any action on the part of the undersigned or Beneficiary) for one year from the initial expiration date and each future expiration date unless we notify you and Applicant in writing at least thirty (30) days prior to any such expiration date that this letter of credit will not be so extended. Any such notice shall be delivered by registered or certified mail, or by FedEx, both to:

Beneficiary at:

and to

And copy to Applicant at:

We hereby agree with drawers that drafts and documents as specified above will be duly honored upon presentation to **[Bank's Name]** and **[Bank's Address]** if presented on or before the then-current expiration date hereof.

Payment of any amount under this Letter of Credit by **[Bank]** shall be made as the Beneficiary shall instruct on the next Business Day after the date the **[Bank]** receives all documentation required hereunder, in immediately available funds on such date. As used in this Letter of Credit, the term "Business Day" shall mean any day other than a Saturday or Sunday or any other day on which banks in the State of **[Note – insert State of bank's location]** are authorized or required by law to be closed.

Unless otherwise expressly stated herein, this irrevocable standby letter of credit is issued subject to the rules of the International Standby Practices, International Chamber of Commerce publication no. 590 ("ISP98")

[Bank's Name]:

[Authorized Signature]

ATTACHMENT H
BESS REQUIREMENTS

SECTION 1 - BESS TESTS

Prior to achieving Commercial Operations, and in each BESS Measurement Period, unless waived by Company, Subscriber Organization shall demonstrate that the BESS satisfies the (1) BESS Capacity Performance Metric, and (2) the RTE Performance Metric, each as defined and further described below.

A. BESS Capacity Performance Metric.

- The BESS Capacity Performance Metric reflecting the net output of the BESS from the Point of Interconnection can be demonstrated either through (i) operational data or (ii) a scheduled formal BESS Capacity Test.
- The "BESS Capacity Performance Metric" shall be deemed to be satisfied where the BESS Capacity Ratio is not less than 100% for an applicable BESS Measurement Period. The "BESS Capacity Ratio" shall be the number, expressed as a percentage, equal to the total "Discharge Energy" (MWh discharge) delivered to the Point of Interconnection to bring the BESS from (i) its maximum State of Charge or (ii) 100% State of Charge to a 0% State of Charge, divided by the BESS Contract Capacity.
- A "BESS Capacity Test" is when the Company coordinates Company Dispatch to demonstrate the BESS maintains the power output required to follow the dispatch signal provided by the Company through a control set point, as measured at the Point of Interconnection, and is able to continuously discharge energy to the Point of Interconnection according to Company Dispatch to bring the BESS from (i) its maximum State of Charge or (ii) 100% State of Charge to a 0% State of Charge.
- The BESS Capacity Test can only be performed when the BESS is at the lower of: (i) its maximum State of Charge or (ii) 100% State of Charge prior to the start of the BESS Capacity Test and during the BESS Capacity Test the Company Dispatch allows for continuous discharge of the BESS to 0% State of Charge with energy delivered to the Point of Interconnection.

B. RTE Performance Metric.

- The "RTE Performance Metric" is set forth in Section 6 (a) (RTE Test and Liquidated Damages) of Attachment C (Required Performance Metrics; Liquidated Damages) to this Contract. The RTE Performance Metric reflecting the charging/discharging of the BESS can be demonstrated either through (i) operational data or (ii) a scheduled formal RTE Test.
- Demonstration of the RTE Performance Metric requires measurement of "Charging Energy" (MWh charge) at the BESS inverters' AC input to bring the BESS from a 0% State of Charge

to a 100% State of Charge from the WTG(s) or grid according to Company Dispatch, followed by measurement at the Point of Interconnection of the "Discharge Energy" (MWh discharge) delivered to the grid to bring the BESS to a 0% State of Charge according to Company Dispatch. The exact equipment and point used for measurement of Charging Energy will be mutually agreed to by the Parties on the Facility's single-line diagram attached as Exhibit F-5 (Single-Line Drawing and Interface Block Diagram) to Attachment F (Facility Owned by Subscriber Organization) to this Contract. For the purposes of evaluating satisfaction of the RTE Performance Metric, the "RTE Ratio" shall be the number, expressed as a percentage, equal to the total Discharge Energy delivered to the Point of Interconnection during the BESS Capacity Test, divided by the Charging Energy measured at the BESS inverters' AC input.

- The formula for the RTE Ratio is as follows: $\text{RTE Ratio} = 100\% \times (\text{MWh discharge})/(\text{MWh charge})$
- The RTE Performance Metric will be deemed to have been "passed" or "satisfied" to the extent the RTE Ratio is not less than the RTE Performance Metric set forth in Section 6 (a) (RTE Test and Liquidated Damages) of Attachment C (Required Performance Metrics; Liquidated Damages) to this Contract.
- An "RTE Test" is when the Company coordinates Company Dispatch to demonstrate the charging/discharging requisite to satisfy the RTE Performance Metric.
- The RTE Test may be conducted concurrently with a BESS Capacity Test.
- For purposes of the RTE Test, the charging cycle shall begin when the BESS is at a 0% State of Charge prior to a (i) 100% discharge cycle or (ii) BESS Capacity Test if being conducted concurrently and the Charging Energy is the amount of energy, as measured at the BESS inverters' AC input, that brings the BESS to a 100% State of Charge.

C. BESS Test Procedures.

- After Commercial Operations, Subscriber Organization shall demonstrate satisfaction of the BESS Capacity Performance Metric by reference to the operational data reflecting the net output of the BESS from the Point of Interconnection, or by conducting a scheduled formal BESS Capacity Test during such BESS Measurement Period. Once Subscriber Organization demonstrates satisfaction of the BESS Capacity Performance Metric through either operational data or a scheduled formal BESS Capacity Test (100% discharge cycle), the BESS shall be deemed to have met the BESS Capacity Performance Metric and satisfied ("passed") the BESS Capacity Test for the applicable BESS Measurement Period.
- After Commercial Operations, Subscriber Organization shall demonstrate satisfaction of the RTE Performance Metric by reference to the operational data reflecting the charging/discharging of the BESS, or by conducting a scheduled formal RTE Test during such BESS Measurement Period. Once Subscriber Organization demonstrates satisfaction of the RTE Performance Metric through either operational data or a scheduled formal RTE Test (100% charge/discharge cycle), the BESS shall be deemed to have met the RTE Performance Metric and satisfied ("passed") the RTE Test for the applicable BESS Measurement Period.

- Any BESS Capacity Test or RTE Test (each a "BESS Test" and collectively, the "BESS Tests") scheduled in lieu of being demonstrated by reference to operational data shall be performed at a time scheduled by the Company in its sole discretion.
- Subscriber Organization shall be permitted up to a total of three (3) BESS Tests (100% discharge cycles) within a BESS Measurement Period to demonstrate satisfaction of the BESS Capacity Performance Metric and RTE Performance Metric for such BESS Measurement Period, unless additional such tests are authorized by Company. If upon completion of the first BESS Test, Subscriber Organization does not "pass" either the BESS Capacity Test or the RTE Test, Company shall attempt to notice up to two (2) additional BESS Tests within a BESS Measurement Period, for Subscriber Organization to further demonstrate its performance. If a scheduled formal BESS Test is requested by Subscriber Organization, Company shall attempt to schedule a formal BESS Test and Company shall provide notice to Subscriber Organization no less than three (3) Business Days prior to conducting such scheduled formal BESS Test.
- If, during a BESS Measurement Period, Subscriber Organization fails to pass a BESS Capacity Test, the BESS shall nevertheless be deemed to have satisfied the BESS Capacity Performance Metric for the applicable BESS Measurement Period if (i) Company failed to notice up to three BESS Capacity Tests in order for Subscriber Organization to further demonstrate the BESS' performance during such BESS Measurement Period, or (ii) Subscriber Organization was unable to perform at least two (2) such noticed BESS Capacity Tests during such BESS Measurement Period due to (a) conditions on the Company System other than Subscriber Organization-Attributable Non-Generation or (b) an act or omission by Company. If Subscriber Organization-Attributable Non-Generation is cause for the inability to demonstrate the BESS Capacity Performance Metric, the BESS Capacity Ratio used to assess LDs shall be the highest demonstrated in operational data or the most recently completed test during the applicable BESS Measurement Period.
- If, during a BESS Measurement Period, Subscriber Organization does not demonstrate satisfaction of the BESS Capacity Performance Metric through operational data or a BESS Capacity Test, assessment of Liquidated Damages will be based on the last of the BESS Capacity Tests performed.
- If, during a BESS Measurement Period, Subscriber Organization both fails to pass a RTE Test noticed by Company and fails to demonstrate satisfaction of the RTE Performance Metric by reference to operational data for such BESS Measurement Period, the BESS shall nevertheless be deemed to have satisfied the RTE Performance Metric for the applicable BESS Measurement Period if (i) Company failed to notice up to three RTE Tests in order for Subscriber Organization to further demonstrate the BESS' performance during such BESS Measurement Period, or (ii) Subscriber Organization was unable to perform at least two (2) such noticed RTE Tests during such BESS Measurement Period due to (a) conditions on the Company System other than Subscriber Organization-Attributable Non-Generation or (b) an act or omission by Company. If Subscriber Organization-Attributable Non-Generation is cause for not adequately demonstrating the RTE Performance Metric, the RTE Ratio used to

assess LDs shall be the highest demonstrated in operational data or the most recently completed test during the applicable BESS Measurement Period.

- If, during a BESS Measurement Period, Subscriber Organization does not demonstrate satisfaction of the RTE Performance Metric through operational data or RTE Tests, assessment of Liquidated Damages will be based on the last of the RTE Tests performed.
- Company will conduct any necessary BESS Test(s) through Company Dispatch. Company shall have the right to attend, observe and receive the results of all BESS Tests. Subscriber Organization shall provide to Company the results of each BESS Test (including time stamped graphs of system performance based in operational data or test data) no later than ten (10) Business Days after any BESS Test.

SECTION 2 – BESS ANNUAL EQUIVALENT AVAILABILITY FACTOR

- A. To the extent the Commercial Operations Date occurs on a date other than the first day of a BESS Measurement Period, the period between the Commercial Operations Date and the first day of the next BESS Measurement Period if any, shall be ignored for purposes of this BESS Availability Factor.
- B. For the purposes of calculating the BESS Annual Equivalent Availability Factor for the first three (3) full BESS Measurement Periods in the first Contract Year, the calculation will assume that the BESS is one hundred percent (100%) available for the remaining hours of the Contract Year.
- C. “BESS Annual Equivalent Availability Factor” shall be calculated as follows:

$$\text{BESS Annual Equivalent Availability Factor} = 100\% \times \frac{AH-ED}{PH}$$

Where:

PH is period hours (8760 hours; except leap year is 8784)

Available Hours (AH) is the number of hours that the BESS is not on Outage. It is sum of all Service Hours (SH) + Reserve Shutdown Hours (RSH).

A “BESS Outage” exists whenever the entire BESS is offline and unable to charge or discharge electric energy and is not in Reserve Shutdown state.

Service Hours (SH) is the number of hours during the applicable BESS Measurement Period and the immediately preceding three (3) full BESS Measurement Period that the BESS is online and (i) charging from the WTGs or the Company System, or (ii) discharging electric energy to the Company System.

Reserve Shutdown Hours (RSH) is the number of hours the BESS is available but not charging or discharging electric energy or is offline at the Company's request for reasons other than Subscriber Organization-Attributable Non-Generation.

A "BESS Derating" exists when the BESS is available but at less than Maximum Rated Output, including deratings due to Subscriber Organization-Attributable Non-Generation or those by Company pursuant to Section 5 (Company Rights of Dispatch) of the Contract. For the avoidance of doubt, if there is a BESS Outage occurring, there cannot also be a BESS Derating.

Equivalent Derated Hours (EDH) is the sum of ESADH, EPDH, and EUDH. For deratings due to BESS inverter unavailability, the equivalent full outage hour(s) are calculated by multiplying the actual duration of the derating (hours) by the number of inverters in the BESS unavailable and dividing by the total number of inverters in the BESS. For deratings that do not impact the availability of an entire BESS inverter or set of entire BESS inverters, the equivalent full outage hour(s) are calculated by multiplying the actual duration of the derating (hours) by the size of the derating (in MW) and dividing by the Maximum Rated Output.

Equivalent Subscriber Organization-Attributable Derated Hours (ESADH): A Subscriber Organization-Attributable Derating occurs when a derating exists due to Subscriber Organization-Attributable Non-Generation or deratings by Company pursuant to Section 8.3 (Company Rights of Dispatch). Each individual derating is transformed into equivalent full outage hour(s). These equivalent hour(s) are then summed for the applicable BESS Measurement Period and the immediately preceding three (3) full BESS Measurement Periods.

EPDH is the equivalent planned derated hours, including Planned Derations (PD) and Maintenance Derations. A Planned Deration is when the BESS experiences a Deration scheduled well in advance and for a predetermined duration. A Maintenance Deration is a Deration that can be deferred beyond the end of the next weekend (Sunday at midnight or before Sunday turns into Monday) but requires a reduction in capacity before the next Planned Deration (PD). Each individual Deration is transformed into equivalent full outage hour(s). These equivalent hour(s) are then summed for the applicable BESS Measurement Period and the immediately preceding three (3) full BESS Measurement Periods.

EUDH is the equivalent unplanned derated hours. An Unplanned Deration (Forced Derating) occurs when the BESS experiences a derating that requires a reduction in availability before the end of the nearest following weekend. Each individual Unplanned Deration is transformed into equivalent full outage hour(s). These equivalent hour(s) are then summed for the applicable BESS Measurement Period and the immediately preceding three (3) full BESS Measurement Periods.

The effect of Force Majeure is taken into account in calculating the BESS Annual Equivalent Availability Factor over a 12 calendar month period as follows: When such 12 month period contains any hours in a month during which the BESS or a portion of the BESS is unavailable due to Force Majeure, then such month shall be excluded from the 12 month period and the calculation period shall be extended back in time to include the next previous month during which there was no such unavailability of the BESS or a portion thereof due to Force Majeure. This means the BESS Equivalent Availability Factor would not change from that determined in the month directly preceding a month containing Force Majeure.

The following examples are provided as illustrative examples only:

Example A: The BESS was continuously available, with no BESS Outages or BESS Deratings during the applicable BESS Measurement Period and in the immediately preceding three (3) full BESS Measurement Periods. In this case AH = 8760 hours, EDH = 0 hours as ESADH, EPDH, and EUDH each = 0 hours

$$\text{BESS EAF} = 100\% \times \frac{8,760-0}{8,760} = 100\%$$

Example B: During the applicable BESS Measurement Period and the immediately preceding three (3) full BESS Measurement Periods: (a) The BESS was online and charging from the PV system or discharging electric energy to the Company System for 8,400 hours and was available but not discharging electric energy due to lack of stored energy (i.e., not Subscriber Organization-Attributable Non-Generation) for 226 hours; (b) The BESS experienced a Planned Derating of 7.2 MWs for 100 hours for maintenance that was scheduled a month in advance; (c) The BESS also experienced an Unplanned Derating of 62 BESS inverters for 100 hours as the derating could not be deferred to beyond the nearest following weekend. (d) The BESS did not experience any outage or derating due to Subscriber Organization-Attributable Non-Generation during this period.

The BESS Maximum Rated Output is 10 MW and the BESS contains 100 total inverters.

$$\text{PH} = 8,760 \text{ hours in 12 calendar months}$$

$$\text{SH} = 8,400 \text{ hours}$$

$$\text{RSH} = 226 \text{ hours}$$

$$\text{AH} = \text{SH} + \text{RSH} = 8,400 + 226 = 8,626 \text{ hours}$$

$$\text{ESADH} = 0$$

$$\text{EPDH} = 100 \text{ hours} \times 7.2 \text{ MW}/10 \text{ MW} = 72 \text{ hours (Planned Maintenance)}$$

$$\text{EUDH} = 100 \text{ hours} \times 62 \text{ inverters}/ 100 \text{ inverters} = 62 \text{ hours (Unplanned Deration (Forced Derating))}$$

$$\text{EDH} = 72 \text{ hours} + 62 \text{ hours} = 134 \text{ hours}$$

$$\text{BESS EAF} = 100\% \times \frac{8,626-134}{8,760} = 96.9\%$$

SECTION 3 - BESS ANNUAL EQUIVALENT FORCED OUTAGE FACTOR

$$EFOF = 100\% \times \frac{(FOH + EUDH)}{8760}$$

Where:

Equivalent Unplanned (Forced) Derated Hours (EUDH) is calculated in accordance with Attachment X (BESS Annual Equivalent Availability Factor) of this Contract.

Forced Outage Hours (FOH) = Sum of all hours the BESS experienced an Unplanned (Forced Outages) during the applicable BESS Measurement Period and the sum of all hours experienced during Unplanned (Forced) Outages during the immediately preceding three (3) full BESS Measurement Periods, in each case caused by Subscriber Organization-Attributable Non-Generation.

Unplanned (Forced) Derating: A Deration that requires a reduction in capacity of the BESS before the end of the nearest following weekend.

Unplanned (Forced) Outage: An outage that requires removal of the entire BESS from service before the end of the nearest following weekend that is not planned, including those caused by Subscriber Organization-Attributable Non-Generation or those imposed by Company pursuant to Section 5. (Company Rights of Dispatch) to the Contract .

EXAMPLE CALCULATION:

Assume a 50 MW BESS that for the BESS Measurement Period in question was completely out of service for 50 hours. For the BESS Measurement Period in question, it also had the following deratings:

Duration of Derating	MW Size Reduction
100 Hours	25 MW
20 Hours	20 MW
50 Hours	5 MW

During the three preceding BESS Measurement Periods, the BESS had a total of 150 Forced Outage Hours and a total of 100 Equivalent Forced Derated Hours.

$$FOH = 50 \text{ hours} + 150 \text{ hours} = 200 \text{ hours}$$

$$EUDH = ((100 \times 25) / 50) + ((20 \times 20) / 50) + ((50 \times 5) / 50) + 100 = 163 \text{ hours}$$

$$EFOF = 100\% \times \frac{(200 + 163)}{8760} = 4.1\%$$

ATTACHMENT I

FACILITY'S CBRE PROGRAM

1. **CBRE Program.** The purpose of the CBRE Program is to facilitate the continued expansion of renewable energy by allowing developers of renewable energy projects to provide Company's retail customers with the opportunity to avail themselves of the benefits of the CBRE Tariff by utilizing CBRE Credits to offset all or a portion of their on-going electricity usage. To this end, Subscriber Organization has established Facility's CBRE Project. Subscriber Organization acknowledges that it has been informed that Facility's CBRE Project must at all times comply with the requirements of the CBRE Program, the CBRE Tariff, the CBRE Framework, guidance from the PUC, guidance from the CBRE IO, and applicable Laws, including (i) the federal securities laws, including the registration requirements under the Securities Act of 1933 and the Securities and Exchange Act of 1934 and all rules and regulations promulgated thereunder (collectively, "Federal Securities Laws"); (ii) the State securities laws, including the registration requirements under the Hawai'i Uniform Securities Act and all rules and regulations promulgated thereunder (collectively, "State Securities Laws"); (iii) Laws concerning the dissemination of personally identifiable information; and (iv) Laws concerning consumer protection. The purpose of this Attachment I (Facility's CBRE Program) is to set forth certain requirements of the CBRE Program as of the Execution Date. Company reserves the right to modify the requirements of the CBRE Program upon PUC order and/or guidance from the CBRE IO where such modifications are necessary to comply with the CBRE Tariff, the CBRE Framework or applicable Laws, and Subscriber Organization shall comply with all such modifications. Without limitation to the generality of the foregoing, in the event of any conflict between the requirements of the CBRE Program, on the one hand, and any one or more of the CBRE Tariff, the CBRE Framework, guidance from the PUC, guidance from the CBRE IO, and/or applicable Laws, on the other hand, the CBRE Tariff, the CBRE Framework, guidance from the PUC, guidance from the CBRE IO, and applicable Laws, shall control and Subscriber Organization shall comply with the CBRE Tariff, the CBRE Framework, guidance from the PUC, guidance from the CBRE IO, and applicable Laws.
2. **Termination, Transfer and Buy-back of Subscriber Allocations.** Termination, transfer and buy-back of Subscriber Allocations shall be governed by the provisions of the CBRE Tariff contingent on whether the Facility's CBRE Program uses the Pay-As -You -Go or Pay-U p-Front model for Subscriber Allocations.
3. **Additional Representations of Subscriber Organization.** Subscriber Organization represents, warrants and covenants that:
 - (a) Subscriber Organization shall disclose to each Account Holder before enrolling such Account Holder as a Subscriber:
 - (1) Subscriber Organization's experience in developing and operating renewable energy projects similar to the Facility.
 - (2) The circumstances under which the Lump Sum Payment can be reduced through the OEPR process and the impact of such reduction on Bill Credits.
 - (3) The circumstances under which the Bill Credits can be reduced if Performance Metrics LDs are unpaid by Subscriber Organization.

- (b) Subscriber Organization shall not knowingly allow the transfer of any Subscriber Allocations at a price other than that set forth in the repurchase/resale price schedule attached to the Subscriber Agreement.
 - (c) Facility's CBRE Program:
 - (1) As of the Execution Date, complies with all applicable Federal Securities Laws, and shall continue to be in compliance for the duration of Facility's CBRE Program.
 - (2) As of the Execution Date, complies with all applicable State Securities Laws, and shall continue to be in compliance for the duration of Facility's CBRE Program.
 - (3) As of the Execution Date, complies with all applicable Laws concerning the dissemination of personally identifiable information, and shall continue to be in compliance for the longer of (i) the duration of Facility's CBRE Program and (ii) for as long as Subscriber Organization continues to hold or otherwise have access to any personally identifiable information of Account Holders or former customers of Company.
 - (4) As of the Execution Date, complies with all applicable Laws concerning consumer protection, and shall continue to be in compliance for the duration of Facility's CBRE Program.
 - (5) Shall achieve the various Subscriber thresholds set forth in Section 5 of Attachment B (Company Payments for Energy, Dispatchability and Availability of BESS).
 - (6) As of the Execution Date, Subscriber Organization is and "approved Subscriber Organization" under the CBRE Tariff and committed to operating, maintaining and administering its CBRE Project in accordance with this Contract and the CBRE Framework for the Term.
5. **Marketing and Sales of the Subscriber Allocations.** Subscriber Organization represents, warrants, and covenants that Subscriber Organization's marketing and sale of the Subscriber Allocations, including but not limited to Subscriber Organization's marketing and sales materials, shall comply with all applicable Federal Securities Laws and State Securities Laws.
6. **CBRE Online Portal and CBRE Program Data.** Subscriber Organization shall utilize the CBRE Online Portal and provide Company with CBRE Program data as required under the CBRE Tariff and/or the CBRE Framework.
7. **Additional Responsibilities.** Subscriber Organization shall perform the responsibilities of "Subscriber Organizations" under the CBRE Framework and the CBRE Tariff, including but not limited to complying with the Subscriber Agreement requirements, complying with the consumer protection measures, unlocking the market for LMI Subscribers and data collection requirements. Subscriber Organization shall cooperate with the CBRE IO as and when requested by the CBRE IO to facilitate the performance of the CBRE IO's responsibilities under the CBRE Framework.
8. **LMI Subscribers.**

- (a) If Subscriber Organization's Facility has been awarded a project from one of Company's CBRE LMI RFP's, then Subscriber Organization has proposed, and hereby agrees, that all Subscribers enrolled for subscriptions in the Facility CBRE Program for this Facility shall be LMI Subscribers.
- (b) If Subscriber Organization, in its bid in response to any other Company CBRE RFP, has pledged to recruit a certain percentage of LMI Subscribers for its Facility CBRE Program, then Subscriber Organization hereby agrees to recruit LMI Subscribers to meet this pledged commitment for LMI Subscribers into Subscriber Organization's Facility CBRE Program.
- (c) If Subscriber Organization has an LMI Subscriber commitment under either Section 8(a) or Section 8(b) of this Attachment I (Facility's CBRE Program), then Subscriber Organization shall comply with the requirements of Part III of the CBRE Tariff to (1) qualify LMI Subscribers, (2) provide verification of Subscriber Organization's confirmation efforts to verify such LMI Subscribers' qualifications upon Company's request, and (3) comply with the minimum applicable requirements for LMI Subscribers and report monthly Subscriber Organization's LMI Subscriber percentage status for Company's review. Subscriber Organization understands and agrees that failure to maintain the required percentages of LMI Subscribers in Subscriber Organization's Facility CBRE Program may subject Subscriber Organization to payment reductions and/or liquidated damages as specified in the CBRE Tariff.

--END--