

BEFORE THE PUBLIC UTILITIES COMMISSION

OF THE STATE OF HAWAII

In The Matter of the Application of )  
 )  
HAWAIIAN ELECTRIC COMPANY, INC., )  
HAWAII ELECTRIC LIGHT COMPANY, INC. )  
MAUI ELECTRIC COMPANY, LIMITED )  
 )  
For Approval to Establish a Rule to Implement )  
a Community-Based Renewable Energy Program, )  
and Other Related Matters. )  
\_\_\_\_\_ )

DOCKET NO. 2015-0389

**THE HAWAIIAN ELECTRIC COMPANIES'**

**COMMUNITY BASED RENEWABLE ENERGY TARIFF AND  
APPENDICES, RFPS AND MODEL CONTRACTS FOR PHASE 2,  
TRANCHE 1**

**Book 2 of 10**

**Filed December 1, 2020**

# EXHIBIT 6

Draft CBRE Tranche 1 Request for Proposals for  
Hawaii Island

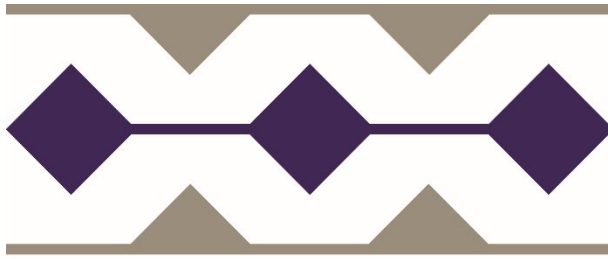

**Hawai'i  
Electric  
Light**

**DRAFT**

**REQUEST FOR PROPOSALS**

**FOR**

**COMMUNITY-BASED RENEWABLE ENERGY TRANCHE 1**

**ISLAND OF HAWAI'I**

DECEMBER 1, 2020

Docket No. 2015-0389

This Request for Proposals (“RFP”) is a DRAFT only. Hawai‘i Electric Light Company, Inc. (“Hawai‘i Electric Light” or the “Company”) will employ a competitive bidding process to select renewable energy projects including Community Based Renewable Energy consistent with the State of Hawai‘i Public Utilities Commission’s (“PUC”) Competitive Bidding Framework. Under the Competitive Bidding Framework, Hawai‘i Electric Light filed the initial draft RFP with the PUC. Then, Hawai‘i Electric Light sought input from prospective Proposers and other stakeholders through a Technical Conference as described in the draft RFP and modified the draft RFP to the extent feasible to address input received in order to foster a robust competitive process. The proposed final RFP is being submitted to the PUC for approval and is subject to further revision based upon direction received from the PUC. After approval by the PUC, Hawai‘i Electric Light will issue the final RFP.

## Table of Contents

Chapter 1: Introduction and General Information .....	1
1.1 Authority and Purpose of the Request for Proposals .....	2
1.2 Scope of the RFP .....	3
1.3 Competitive Bidding Framework .....	5
1.4 Role of the Independent Observer .....	5
1.5 Communications Between the Company and Proposers – Code of Conduct Procedures Manual.....	6
1.6 Company Contact for Proposals .....	7
1.7 Proposal Submittal Requirements.....	7
1.8 Proposal Fee.....	8
1.9 Procedures for the Self-Build or Affiliate Proposals .....	9
1.10 Dispute Resolution Process.....	11
1.11 No Protest or Appeal.....	12
1.12 Modification or Cancellation of the Solicitation Process .....	12
Chapter 2: Resource Needs and Requirements.....	13
2.1 Performance Standards .....	13
2.2 Distribution Level System Information .....	13
2.3 Interconnection to the Company System .....	14
Chapter 3: Instructions to Proposers .....	15
3.1 Schedule for the Proposal Process .....	15
3.2 Company RFP Website / Electronic Procurement Platform.....	15
3.3 Information Exchange.....	16
3.4 Preparation of Proposals .....	16
3.5 Organization of the Proposal .....	17
3.6 Proposal Limitations .....	17
3.7 Proposal Compliance and Bases for Disqualification.....	18
3.8 Power Purchase Agreement .....	18
3.9 Pricing Requirements.....	20
3.10 Project Description.....	21
3.11 Sites Identified by the Company.....	22
3.12 Confidentiality .....	23



3.13	Credit Requirements .....	23
Chapter 4: Evaluation Process and Evaluation Criteria.....		24
4.1	Proposal Evaluation and Selection Process .....	24
4.2	Eligibility Requirements Assessment .....	26
4.3	Threshold Requirements Assessment .....	26
4.4	Initial Evaluation – Price and Non-Price Analysis .....	29
4.5	Selection of a Priority List .....	37
4.6	Best and Final Offer (BAFO) .....	38
4.7	Detailed Evaluation.....	38
4.8	Selection of the Final Award Group .....	40
Chapter 5: Post Evaluation Process .....		41
5.1	Project Interconnection Process.....	41
5.2	Contract Negotiation Process.....	42
5.3	Community Outreach and Engagement.....	43
5.4	Greenhouse Gas Emissions Analysis.....	44
5.5	PUC Approval.....	45
5.6	Facility In-Service.....	45

## List of Appendices

Appendix A	Definitions
Appendix B	Proposer's Response Package / Project Interconnection Data Request
Appendix C	Code of Conduct Procedures Manual
Appendix D	PowerAdvocate User Information
Appendix E	Mutual Confidentiality and Non-Disclosure Agreement
Appendix F	Description of Available Sites
Appendix G	Self-Build Option and Self-Build Option Team Certification Form
Appendix H	Interconnection Facilities and Cost Information
Appendix I	Rule 19 Tariff
Appendix J	Rule 29 Tariff
Appendix K	Model PV Large RDG PPA
Appendix L	Model PV Mid-Tier Standard Form Contract RDG PPA (250 kW to 2.5 MW)
Appendix M	Model Wind Large RDG PPA
Appendix N	Model Wind Mid-Tier Standard Form Contract RDG PPA (250 kW to 2.5 MW)
Appendix O	Grid Needs Assessment
Appendix P	Term Sheet for Large CBRE DC-Coupled Projects (PV + BESS)

## **Chapter 1: Introduction and General Information**

Hawai'i Electric Light Company, Inc. ("Hawai'i Electric Light" or the "Company") seeks proposals for Community-Based Renewable Energy ("CBRE") projects, also referred to as shared solar<sup>1</sup>, in this Tranche 1 for the Hawai'i Electric Light System on the island of Hawai'i in accordance with this Request for Proposals ("RFP").

The Company or its Affiliates may submit a Proposal in response to this RFP subject to the requirements of this RFP.

The Company seeks new variable renewable dispatchable generation projects (with or without storage systems) in this RFP. The total amount of CBRE generation sought in this RFP is 12.5 MW. For projects 250 kW or greater in size, up to and including 2.5 MW, a pre-approved standard form contract will be used in the form of Appendix L for photovoltaic ("PV") generation projects and Appendix N for wind generation projects ("Mid-Tier SFC"). The Mid-Tier SFC treats variable generation facilities as fully dispatchable. For projects greater than 2.5 MW in size, the Company intends to contract for variable renewable dispatchable generation projects through this RFP using its Model Renewable Dispatchable Generation Power Purchase Agreement ("RDG PPA"), which treats variable generation facilities as fully dispatchable. The Company has created a PV version (the "PV RDG PPA") and a wind version (the "Wind RDG PPA") of its RDG PPA attached as Appendix K and Appendix M, respectively.

Each successful Proposer will provide variable renewable dispatchable generation and optionally energy storage to the Company pursuant to the terms of an RDG PPA or Mid-Tier SFC. RDG PPAs for selected projects greater than 2.5 MW in size will be subject to review and approval by the State of Hawai'i Public Utilities Commission ("PUC"), while the Mid-Tier SFCs for projects selected in this RFP that are 250 kW or greater in size, up to and including 2.5 MW will not be subject to further PUC review and approval.

The Company's Model RDG PPA and Mid-Tier SFC employ an innovative contracting mechanism which is very different than traditional PPA structures. Proposers are instructed to thoroughly review the Model RDG PPA attached as Appendix J and L and the Mid-Tier SFC attached as Appendix K and M, based on the size and technology of their project. The structure of the RDG PPA and Mid-Tier SFC intends to provide payments to the Proposer by the Company on a monthly lump sum basis, based upon the energy potential of the facility, regardless of the actual energy dispatched. In exchange, the utility maintains full dispatch

---

<sup>1</sup> In response to some confusion in the community over the acronym "CBRE" that the Companies have experienced during their latest efforts to publicize the CBRE Program, the Companies are introducing the more descriptive term "shared solar" for the CBRE Program in an effort to alleviate any further confusion in the community. The Companies intent is to use both terms, "CBRE" in regulatory filings and "shared solar" in marketing and other Company literature to refer to the Community-Based Renewable Energy Program first introduced by the CBRE Framework. The term, "shared solar" will be used even though the CBRE Program is not necessarily limited to PV projects only.

control of the Facility as needed.<sup>2</sup> Under the RDG PPA and Mid-Tier SFC, each Facility must meet certain requirements to receive the full lump sum payment each month. These requirements ensure that each plant is available to the Company for dispatch to meet system needs.

The Company will evaluate Proposals using the evaluation and selection process described in Chapter 4. The Company will evaluate and select Proposals based on both price and non-price factors that impact the Company, its customers, and communities affected by the proposed Projects. The number of Projects that the Company may acquire from this RFP depends on, among other things, the quality and cost-effectiveness of bids received in response to this RFP; economic comparison to other RFP responses; updates to the Company's forecasts; distribution availability; and changes to regulatory or legal requirements. If attractive Proposals are received that will provide energy and energy storage in excess of the targeted amounts, the Company will consider selecting such Proposal(s) if benefits to customers are demonstrated.

All requirements necessary to submit a Proposal(s) are stated in this RFP. A description of the technical requirements for Proposers is included in the body of this RFP, Appendix B, and in the applicable RDG PPA and Mid-Tier SFC attached as Appendix K, L, M, and N.

All capitalized terms used in this RFP shall have the meaning set forth in the glossary of defined terms attached as Appendix A. Capitalized terms that are not included in Appendix A shall have the meaning ascribed in this RFP.

## **1.1 Authority and Purpose of the Request for Proposals**

- 1.1.1 This RFP is issued in response to Order No. 37070 issued on April 20, 2020 and Order No. 37139 issued on May 14, 2020 in Docket No. 2015-0389 as part of a procurement process established by the PUC.
- 1.1.2 This RFP is subject to Decision and Order (“D&O”) No. 23121 in Docket No. 03-0372 (To Investigate Competitive Bidding for New Generating Capacity in Hawai‘i), which sets forth the PUC’s Framework for Competitive Bidding (“Framework” or “Competitive Bidding Framework”).
- 1.1.3 Proposers should review Appendix O, Grid Needs Assessment, to inform Proposers as to the system needs and costs based on inputs and assumptions developed through the Company’s integrated grid planning process, and recent renewable dispatchable generation procurements.<sup>3</sup> The Grid Needs Assessment is intended to inform the development of their Proposals that best meets the needs of the system.

---

<sup>2</sup> Wind projects may include a Price for Purchase of Electric/Renewable Energy component in addition to the Lump Sum Payment component. The energy payment would be based on actual production and delivery to the grid. As the RDG PPA and Mid-Tier SFC allow the Company dispatch rights and does not guarantee Seller any amount of energy will be delivered to the Point of Interconnection (POI), in the event that the Company does not accept any energy at the POI, the Company will not pay any Price for Electric/Renewable Energy.

<sup>3</sup> See <https://www.hawaiianelectric.com/clean-energy-hawaii/our-clean-energy-portfolio/renewable-project-status-board>

## 1.2 Scope of the RFP

- 1.2.1 Proposals submitted in response to this RFP shall meet the requirements identified in Part II and III of Tariff Rule No. 29, Community-Based Renewable Energy Program Phase 2, attached as Appendix J.
- 1.2.2 The Company will only accept Proposals that utilize PV or wind generation technologies. Proposals may be submitted as: (1) Generation only Projects; or (2) Generation paired with energy storage Projects (“Paired Projects”).
- 1.2.3 At least 40% of the Project’s capacity must be reserved for residential Subscribers with unsubscribed RDG compensation subject to the requirements in Article 2 of the applicable RDG PPA or Attachment C of the applicable Mid-Tier SFC. The capacity allocations (%) identified in the Proposal submission will be used in the RFP evaluation process and therefore Proposers will be held to their provided value.
- 1.2.4 Preference will be given to Projects whose Subscriber portion reserves an amount greater than 40% of Project capacity for residential customers and/or any additional amount of Project capacity dedicated to Low- and Moderate-Income Customers (“LMI Customers”), as defined in Tariff Rule No. 29 in Appendix J.
- 1.2.5 Each Proposal submitted in response to this RFP must represent a Project that is capable of meeting the requirements of this RFP without having to rely on the completion or implementation of any other Project, or without having to rely on a proposed change in law, rule, or regulation.
- 1.2.6 Proposals that will require system upgrades and the construction of which, in the reasonable judgment of the Company (in consultation with the Independent Observer), creates a significant risk that their Project’s Guaranteed Commercial Operations Date (“GCOD”) will not be met, will not be considered in this RFP.
- 1.2.7 Projects submitted in response to this RFP must be located on the Island of Hawai‘i.
- 1.2.8 Proposers will determine their Project Site. Proposers have the option of submitting a Proposal using potential Sites offered and described in Section 3.11. Proposers must locate all Project infrastructure within areas of their Site that are outside the 3.2 feet sea level rise exposure area (SLR-XA) as described in the Hawai‘i Sea Level Rise Vulnerability and Adaptation Report (2017)<sup>4</sup> and are not located within a Tsunami Evacuation Zone.<sup>5</sup> All equipment required for a Proposer’s project must be sited within

---

<sup>4</sup> Hawai‘i Climate Change Mitigation and Adaptation Commission. 2017. Hawai‘i Sea Level Rise Vulnerability and Adaptation Report. Prepared by Tetra Tech, Inc. and the State of Hawai‘i Department of Land and Natural Resources, Office of Conservation and Coastal Lands, under the State of Hawai‘i Department of Land and Natural Resources Contract No: 64064. This report is available at: [https://climateadaptation.hawaii.gov/wp-content/uploads/2017/12/SLR-Report\\_Dec2017.pdf](https://climateadaptation.hawaii.gov/wp-content/uploads/2017/12/SLR-Report_Dec2017.pdf)

<sup>5</sup> See Hawai‘i Sea Level Rise Viewer at <https://www.pacioos.hawaii.edu/shoreline/slr-hawaii/>, and National Oceanic and Atmospheric Administration (NOAA) interactive map in partnership with the State of Hawai‘i at <https://tsunami.coast.noaa.gov/#/>. Projects infrastructure must be outside the “Tsunami Evacuation Zone” (but not necessary to be outside the “Extreme Tsunami Evacuation Zone”).

the Proposer's project site with no assumptions that any equipment will be sited on Company property unless specified by the Company.

- 1.2.9 Projects must interconnect to the Company's System at the distribution level (12 kV or lower). Projects interconnecting at the distribution level must not exceed 3 MW.
- 1.2.10 Projects submitted in response to this RFP must be 250 kW or larger. Proposers for CBRE projects smaller than 250 kW should refer to the Company's CBRE website for instructions on how to submit proposals at [www.hawaiianelectric.com/communitysolar](http://www.hawaiianelectric.com/communitysolar).
- 1.2.11 Contracts for Projects selected through this RFP must use the RDG PPA or Mid-Tier SFC, as described in [Section 3.8](#). Under the RDG PPA and Mid-Tier SFC, the Company shall maintain exclusive rights to fully direct dispatch of the Facility, subject to availability of the resource and [Section 1.2.12](#) below. The term of the PPA will be 20 years.
- 1.2.12 The storage component of a Paired Project will be charged during periods when full potential export of the generation component is not being dispatched by the Company, and the storage component can be used to provide energy to the Company during other times that are beneficial to the system. The storage component of a Paired Project must be sized to support the Facility's Allowed Capacity (in MW) for a minimum of four (4) continuous hours throughout the term of the RDG PPA or Mid-Tier SFC.  
  
For example, for a 2 MW facility, the storage component must be able to store and discharge at least 8 MWh of energy at 2 MW in a cycle throughout the term of the RDG PPA or Mid-Tier SFC.
- 1.2.13 Grid-charging is not required for Paired Projects. However, if grid-charging capability is included, the Paired Project must be able to be charged from the grid at the direction of the Company after the 5-year Investment Tax Credit ("ITC") recapture period has lapsed. Paired Projects electing to include grid-charging capability that are incapable of claiming the ITC must be capable of being 100% charged from the grid from the GCOD.
- 1.2.14 The amount of energy discharged from any energy storage component in a year will be limited to the energy storage contract capacity (in MWh) multiplied by the number of Days in that year. An energy storage component may be dispatched more than once per Day, subject to such discharge energy limitations.
- 1.2.15 Proposals must specify a GCOD no later than March 31, 2026. Preference will be given to Proposals that specify an earlier GCOD during the non-price evaluation. A Proposer's GCOD set forth in its Proposal will be the GCOD in any resulting RDG PPA or Mid-Tier SFC if such Proposal is selected to the Final Award Group. Proposers will not be able to request a change in the GCOD set forth in their Proposals. Proposals that propose an earlier GCOD will be scored higher during the Initial Evaluation phase ([see Chapter 4](#)).
- 1.2.16 If selected, Proposers will be responsible for all costs throughout the term of the RDG PPA or Mid-Tier SFC, including but not limited to Project development, completion of an Interconnection Requirements Study ("IRS"), the cost of conducting a greenhouse gas

analysis, land acquisition, permitting, financing, construction of the Facility and all Interconnection Facilities, and the operation and maintenance (“O&M”) of the Facility.

- 1.2.17 If selected, Proposers will be solely responsible for the decommissioning of the Project and the restoration of the Site upon the expiration of the PPA, as described in Attachment G, Section 7 of the RDG PPA or the Mid-Tier SFC.
- 1.2.18 If selected, Proposers shall pursue all available applicable federal and state tax credits. Proposal pricing must be set to incorporate the benefit of such available federal tax credits. However, to mitigate the risk on Proposers due solely to potential changes to the state’s tax credit law before a selected project reaches commercial operations, Proposal pricing shall be set without including any state tax credits. If a Proposal is selected, the PPA for the project will require the Proposer to pursue the maximum available state tax credit and remit tax credit proceeds to the Company for customers’ benefit as described in Attachment J of the RDG PPA or the Mid-Tier SFC. The PPA will also provide that the Proposer will be responsible for payment of liquidated damages for failure to pursue the state tax credit.

### **1.3 Competitive Bidding Framework**

Consistent with the Framework, this RFP outlines the Company’s requirements in relation to the resources being solicited and the procedures for conducting the RFP process. It also includes information and instructions to prospective Proposers participating in and responding to this RFP.

### **1.4 Role of the Independent Observer**

- 1.4.1 Part III.C.1 of the Framework sets forth the circumstances under which an Independent Observer is required in a competitive bidding process. The Independent Observer will advise and monitor all phases of the RFP process and will coordinate with PUC staff throughout the RFP process to ensure that the RFP is undertaken in a fair and unbiased manner. In particular, the Company will review and discuss with the Independent Observer decisions regarding the evaluation, disqualification, non-selection, and selection of Proposals.
- 1.4.2 The role of the Independent Observer, as described in the Framework, will include but is not limited to:
- Monitor all steps in the competitive bidding process
  - Monitor communications (and communications protocols) with Proposers
  - Monitor adherence to the Company’s Code of Conduct
  - Submit comments and recommendations, if any, to the PUC concerning the RFP
  - Review the Company’s Proposal evaluation methodology, models, criteria, and assumptions
  - Review the Company’s evaluation of Proposals
  - Advise the Company on its decision-making
  - Participate in dispute resolution as set forth in Section 1.10
  - Monitor contract negotiations with Proposers

- Report to the PUC on monitoring results during each stage of the competitive bidding process
- Provide an overall assessment of whether the goals of the RFP were achieved

1.4.3 The Independent Observer for this RFP is: **Arroyo Seco Consulting**.

**1.5 Communications Between the Company and Proposers – Code of Conduct Procedures Manual**

1.5.1 Communications and other procedures under this RFP are governed by the “Code of Conduct Procedures Manual,” (also referred to as the “Procedures Manual”) developed by the Company as required by the Framework, and attached as Appendix C.

1.5.2 All pre-Proposal communication with prospective Proposers will be conducted via the Company’s RFP website, Electronic Procurement Platform, and/or electronic mail (“Email”) through the address specified in Section 1.6 (the “RFP Email Address”). Phone communication or face-to-face meetings will not be supported. Frequently asked questions submitted by prospective Proposers and the answers to those questions may be posted on the Company’s RFP website. The Company reserves the right to respond only to comments and questions it deems are appropriate and relevant to the RFP. Proposers shall submit questions no later than fifteen Days before the Proposal Due Date (RFP Schedule in Section 3.1, Items 6 and 7). The Company will endeavor to respond to all questions no later than five Days before the Proposal Due Date.

1.5.3 After Proposals have been submitted, the Company may contact individual Proposers for purposes of clarifying their Proposal(s).

1.5.4 Any confidential information deemed by the Company, in its sole discretion, to be appropriate to share, will only be transmitted to the requesting party after receipt of a fully executed CBRE Mutual Confidentiality and Non-Disclosure Agreement (“CBRE NDA”). See Appendix E.

1.5.5 Except as expressly permitted and in the manner prescribed in the Procedures Manual, any unsolicited contact by a Proposer or prospective Proposer with personnel of the Company pertaining to this RFP is prohibited.



## 1.6 Company Contact for Proposals

The primary contact for this RFP is:

Ken Horita  
Energy Contract Manager  
Hawaiian Electric Company, Inc.

RFP Email Address: [cbrrerfp@hawaiianelectric.com](mailto:cbrrerfp@hawaiianelectric.com)

## 1.7 Proposal Submission Requirements

- 1.7.1 All Proposals must be prepared and submitted in accordance with the procedures and format specified in the RFP. Proposers are required to respond to all questions and provide all information requested in the RFP, as applicable, and only via the communication methods specified in the RFP.
- 1.7.2 Detailed requirements regarding the form, submission, organization and information for the Proposal are set forth in Chapter 3 and Appendix B.
- 1.7.3 Proposals must not rely on any information that is not contained within the Proposal itself in demonstrating compliance for any requirement in this RFP.
- 1.7.4 In submitting a Proposal in response to this RFP, each Proposer certifies that the Proposal has been submitted in good faith and without fraud or collusion with any other unaffiliated person or entity. The Proposer shall acknowledge this in the Response Package submitted with its Proposal. Furthermore, in executing the CBRE NDA provided as Appendix E, the Proposer agrees on behalf of its Representatives (as defined in the CBRE NDA) that the Company's negotiating positions will not be shared with other Proposers or their respective Representatives.

In addition, in submitting a Proposal, a Proposer will be required to provide Company with its legal counsel's written certification in the form attached as Appendix B Attachment 1 certifying in relevant part that irrespective of any Proposer's direction, waiver, or request to the contrary, that the attorney will not share a Proposer's confidential information associated with such Proposer with others, including, but not limited to, such information such as a Proposer's or Company's negotiating positions. If legal counsel represents multiple unaffiliated Proposers whose Proposals are selected for the Final Award Group, such counsel will also be required to submit a similar certification at the conclusion of power purchase agreement negotiations that he or she has not shared a Proposer's confidential information or the Company's confidential information associated with such Proposer with others, including but not limited to, such information as a Proposer's or Company's negotiating positions.

- 1.7.5 All Proposals must be submitted via the Electronic Procurement Platform by 2:00 pm Hawai'i Standard Time ("HST") on the Proposal Due Date shown in the RFP Schedule in Section 3.1, Table 1, Item 6 and 7. No hard copies of these Proposals will be accepted by the Company.

It is the Proposer’s sole responsibility to ensure that complete and accurate information has been submitted on time and consistent with the instructions of this RFP. With this assurance, Company shall be entitled to rely upon the completeness and accuracy of every Proposal. Any errors identified by the Proposer or Company after the Proposal Due Date has passed may jeopardize further consideration and success of the Proposal. If an error or errors are later identified, Company, in consultation with the Independent Observer, may permit the error(s) to be corrected without further revision to the Proposal, or may require Proposer to adhere to terms of the Proposal as submitted without correction. Additionally, and in Company’s sole discretion, if such error(s) would materially affect the Priority List or Final Award Group, Company reserves the right, in consultation with the Independent Observer, to remove or disqualify a Proposal upon discovery of the material error(s). The Proposer of such Proposal shall bear the full responsibility for such error(s) and shall have no recourse against Company’s decision to address Proposal error(s), including removal or disqualification. The Energy Contract Manager, in consultation with the Independent Observer, will confirm that the Self-Build Proposals were submitted by the Self-Build Proposal Due Date shown in Section 3.1, Table 1, Item 6. The Electronic Procurement Platform automatically closes to further submissions after the IPP and Affiliate Proposal Due Date shown in Section 3.1, Table 1, Item 7.

**1.8 Proposal Fee**

1.8.1 IPP and Affiliate proposers are required to tender a non-refundable Proposal Fee, based on the size of the proposed Project, for each Proposal submitted.

<b>Project Size</b>	<b>Proposal Fee</b>
250 kW and larger, up to and including 2.5 MW	\$2,000
Larger than 2.5 MW, up to and including 3 MW	\$5,000

1.8.2 Proposers may submit up to two (2) variations of their Proposal, one of which is the base variation of the Proposal, under a single Proposal Fee.

1.8.3 Variations of pricing terms, Facility size or with/without storage can be offered. Variations which propose a different Site or different generation technology will not be considered and will be deemed a separate Proposal, and a separate Proposal Fee must be paid for each such Proposal. All unique information for each variation of a Proposal, no matter how minor such variation is, must be clearly identified and separated by following the instructions in Appendix B Section 4.

1.8.4 The Proposal Fee must be in the form of a cashier’s check or equivalent from a U.S.-chartered bank made payable to “Hawai’i Electric Light, Inc.” and must be delivered and received by the Company by 2:00 pm (HST) on the Proposal Due Date shown in the RFP Schedule in Section 3.1, Table 1, Item 7. The cashier’s check should include a reference

to the Proposal(s) for which the Proposal Fee is being provided. Proposers must identify in the Proposal Response Package (instructions in [Appendix B Section 1.3.1](#)) the delivery information for its Proposal Fee. Proposers are strongly encouraged to utilize a delivery service method that provides proof of delivery to validate delivery date and time.

If the Proposal Fee is delivered by U.S. Postal Service (with registered, certified, receipt verification), the Proposer shall address it to:

Ken Horita  
Energy Contract Manager  
Hawaiian Electric Company, Inc.  
Mail Code CP21-IU  
PO Box 2750  
Honolulu, Hawai'i 96840

If the Proposal Fee is delivered by other courier services, the Proposer shall address it to:

Hawaiian Electric Company, Inc.  
Ward Receiving  
Attention: Ken Horita, Energy Contract Manager  
Mail Code CP21-IU  
799 S. King St.  
Honolulu, Hawai'i 96813

Due to COVID-19 disease prevention measures, Proposal Fees cannot be delivered in person.

## **1.9 Procedures for the Self-Build or Affiliate Proposals**

- 1.9.1 Order No. 37070 states that the CBRE RFPs will be open to all bidders, including the Company. The Competitive Bidding Framework allows the Company the option to offer a Proposal(s) in response to this RFP ("Self-Build Option" or "SBO"). Accordingly, the Company must follow certain requirements and procedures designed to safeguard against and address concerns associated with: (1) preferential treatment of the SBO or members, agents, or consultants of the Company formulating the SBO (the "Self-Build Team"); and (2) preferential access to proprietary information by the Self-Build Team. These requirements are specified in the Code of Conduct ("CBRE Code of Conduct") required under the Framework and implemented by certain rules and procedures found in the Procedures Manual submitted to the PUC in Docket No. 2015-0389 on October 9, 2020. The CBRE Code of Conduct will apply to all CBRE Phase 2 RFPs, regardless of whether the Company submits an SBO Proposal. A copy of the Procedures Manual is attached as [Appendix C](#).

The Competitive Bidding Framework also allows Affiliates of the Company to submit Proposals<sup>6</sup> to RFPs issued by the Company. All Self-Build and Affiliate Proposals are

---

<sup>6</sup> A Proposal will also be treated as an Affiliate Proposal if the Affiliate is a partner for the Proposal.

subject to the Company's Code of Conduct and the Procedures Manual. Affiliate Proposals are also subject to any applicable Affiliate Transaction Requirements issued by the PUC in Decision and Order No. 35962 on December 19, 2018, and subsequently modified by Order No. 36112, issued on January 24, 2019, in Docket No. 2018-0065. However, for Affiliate Proposals with nameplate capacities that are 250 kW or greater in size, up to and including 2.5 MW, the PUC will not require an additional review pursuant to the Affiliate Transaction Requirements, but will hold Affiliate Proposals to the terms of their Proposals. Affiliate Proposals will be treated identically to IPP Proposals and must be submitted electronically through the Electronic Procurement Platform by IPP and Affiliate Proposal Due Date in RFP Section 3.1, Table 1, Item 7.

- 1.9.2 The Company will require that the Proposal for the SBO(s) and Affiliate Proposals be submitted electronically through the Electronic Procurement Platform. SBO Proposals will be due a minimum of one (1) Day before other Proposals are due. A Proposal for the SBO will be uploaded into the Electronic Procurement Platform in the same manner Proposals from other Proposers are uploaded. The Energy Contract Manager, in consultation with the Independent Observer, will confirm that the Self-Build Proposals are timestamped by the Self-Build Proposal Due Date found in RFP Section 3.1, Table 1, Item 6.
- 1.9.3 Detailed requirements for an SBO Proposal can be found in Appendix G. These requirements are intended to provide a level playing field between SBO Proposals and third-party Proposals. Except where specifically noted, an SBO Proposal must adhere to the same price and non-price Proposal requirements as required of all Proposers, as well as certain RDG PPA or Mid-Tier SFC requirements, such as milestones and liquidated damages, as described in Appendix G. The non-negotiability of the Performance Standards shall apply to any SBO to the same extent it would for any other Proposal. Notwithstanding the fact that it will not be required to enter into an RDG PPA or Mid-Tier SFC with the Company, a Self-Build Proposer will be required to note its exceptions, if any, to the RDG PPA for Projects over 2.5 MW in the same manner required of other Proposers, and will be held to such modified parameters if selected. In addition to its Proposal, the Self-Build Team will be required to submit Appendix G Attachment 1, Self-Build Option Team Certification Form, acknowledging it has followed the rules and requirements of the RFP to the best of its ability and has not engaged in any collusive actions or received any preferential treatment or information providing an impermissible competitive advantage to the Self-Build Team over other Proposers responding to this RFP, as well as adherence to RDG PPA or Mid-Tier SFC terms and milestones required of all Proposers and the SBO's proposed cost protection measures.

The cost recovery methods between a regulated utility SBO Proposal and IPP Proposals are fundamentally different due to the business environments they operate in. As a result, the Company has instituted a process to compare the two types of proposals for the initial evaluation of the price related criteria on a 'like' basis through comparative analysis.

At the core of an SBO Proposal are its total project capital cost and any associated annual operations and maintenance ("O&M") costs. During the RFP's initial pricing evaluation

step, these capital costs<sup>7</sup> and O&M costs will be used in a revenue requirement calculation to determine the estimated revenues needed from customers which would allow the Company to recover the total cost of the project. The SBO revenue requirements are then used in a levelized benefit calculation to determine a Levelized Benefit (“LB”) (\$/MWh) which will then be used for comparison to IPP and any Affiliate Proposals.

The Company, in conjunction with the Independent Observer, may also conduct a risk assessment of the SBO Proposal to ensure an appropriate level of customer cost protection measures are included in such Proposal.

If the SBO is not included in any shared savings mechanism for this RFP pre-approved by the Commission, the SBO will be permitted to submit a shared savings mechanism with its Proposal to share in any cost savings between the amount of cost bid in the SBO Proposal and the actual cost to construct the Project. If the SBO Proposal is selected to the Final Award Group, the proposed shared savings mechanism will need to be approved by the PUC. Submission of a shared savings mechanism is not required and will not be considered in the evaluation of the SBO Proposal.

## **1.10 Dispute Resolution Process**

- 1.10.1 If disputes arise under the RFP, the provisions of Section 1.10 and the dispute resolution process established in the Framework will control. See Part V of the Framework.
- 1.10.2 Proposers who challenge or contest any aspect of the RFP process must first attempt to resolve their concerns with the Company and the Independent Observer (“Initial Meeting”). The Independent Observer will seek to work cooperatively with the parties to resolve any disputes or pending issues and may offer to mediate the Initial Meeting to resolve disputes prior to such issues being presented to the PUC.
- 1.10.3 Any and all disputes arising out of or relating to the RFP which remain unresolved for a period of twenty (20) Days after the Initial Meeting takes place may, upon the agreement of the Proposer and the Company, be submitted to confidential Mediation in Honolulu, Hawai‘i, pursuant to and in accordance with the Mediation Rules, Procedures, and Protocols of Dispute Prevention Resolution, Inc. (“DPR”) (or its successor) or, in its absence, the American Arbitration Association then in effect (“Mediation”). The Mediation will be administered by DPR. If the parties agree to submit the dispute to Mediation, the Proposer and the Company shall each pay fifty percent (50%) of the cost of the Mediation (i.e., the fees and expenses charged by the mediator and DPR) and shall otherwise each bear their own Mediation costs and attorney’s fees.
- 1.10.4 If settlement of the dispute is not reached within sixty (60) Days after commencement of the Mediation, or if after the Initial Meeting, the parties do not agree to submit any

---

<sup>7</sup> SBO Proposals will be required to provide a table identifying project costs by year. These capital costs should be all inclusive, including but not limited to costs associated with equipment, Engineering, Procurement, and Construction (“EPC”), interconnection, overhead, and Allowance for Funds Used During Construction (“AFUDC”).

unresolved disputes to Mediation, then as provided in the Framework, the Proposer may submit the dispute to the PUC in accordance with the Framework.

- 1.10.5 In accordance with the Framework, the PUC will serve as the arbiter of last resort for any disputes relating to this RFP involving Proposers. The PUC will use an informal expedited dispute resolution process to resolve the dispute within thirty (30) Days, as described in Parts III.B.8 and V of the Framework.<sup>8</sup> There will be no right to hearing or appeal from this informal expedited dispute resolution process.
- 1.10.6 If any Proposer initiates a dispute resolution process for any dispute or claim arising under or relating to this RFP, other than that permitted by the Framework and Section 1.10 (e.g., a court proceeding), then such Proposer shall be responsible for any and all attorneys' fees and costs that may be incurred by the Company or the PUC in order to resolve such claim.

### **1.11 No Protest or Appeal**

Subject to Section 1.10, no Proposer or other person will have the right to protest or appeal any award or disqualification of a Project made by the Company.

By submitting a Proposal in response to the RFP, the Proposer expressly agrees to the terms and conditions set forth in this RFP.

### **1.12 Modification or Cancellation of the Solicitation Process**

- 1.12.1 Unless otherwise expressly prohibited, the Company may, at any time up to the final execution of an RDG PPA or Mid-Tier SFC, as may be applicable, in consultation with the Independent Observer, postpone, withdraw, and/or cancel any requirement, term, or condition of this RFP, including deferral of the award or negotiation of any contract, and/or cancellation of the award all together, all of which will be without any liability to the Company.
- 1.12.2 The Company may modify this RFP subject to requirements of the Framework, whereby the modified RFP will be reviewed by the Independent Observer and submitted to the PUC thirty (30) Days prior to its issuance, unless the PUC directs otherwise. See Framework Part IV.B.10. The Company will follow the same procedure with regard to any potential postponement, withdrawal, or cancellation of the RFP or any portion thereof.

---

<sup>8</sup> The informal expedited dispute resolution process does not apply to PUC review of contracts that result from the RFP. See Decision and Order No. 23121 at 34-35. Further, the informal expedited dispute resolution process does not apply to the Framework's process relating to issuance of a draft and final RFP, and/or to the PUC approval of the RFP because: (1) the Framework (and the RFP) set forth specific processes whereby interested parties may provide input through the submission of comments; and (2) the Framework's dispute resolution process applies to "Bidders" and there are no "Bidders" at this stage in the RFP process.

## **Chapter 2: Resource Needs and Requirements**

### **2.1 Performance Standards**

Proposals must meet the attributes set forth in this RFP, the technical requirements identified in Appendix I of Rule 14H, and either the requirements of the applicable RDG PPA for proposals greater than 2.5 MW or Mid-Tier SFC for proposals 250 kW or greater, up to and including 2.5 MW. This RFP, Rule 14H, and either the applicable RDG PPA or the Mid-Tier SFC set forth the minimum requirements that all Proposals must satisfy to be eligible for consideration in this RFP. If there is a conflict between the Performance Standards in Rule 14H and the applicable RDG PPA or Mid-Tier SFC, the contract terms will control. Additional Performance Standards may be required based on the results of the IRS.

- 2.1.1 For Paired Projects, the functionality and characteristics of the storage must be maintained throughout the term of the RDG PPA or Mid-Tier SFC. To be clear, Proposers may not propose any degradation for either capacity or efficiency in their Proposals.
- 2.1.2 Grid forming and black start capability<sup>9</sup> are preferred but not required.

### **2.2 Distribution-Level System Information**

Proposers are encouraged to use the Locational Value Maps located at <https://www.hawaiianelectric.com/clean-energy-hawaii/integration-tools-and-resources/locational-value-maps> to determine circuit capacity. However, while the Locational Value Map provides information regarding an initial assessment of the potential MW hosting capacity for distribution level circuits, these numbers should only be used as a screening tool to select a circuit that will provide a higher likelihood of interconnection. This is because the methodology used to develop these hosting capacity numbers is geared towards smaller distributed energy resources (“DER”) and does not include the scenario of a larger DER interconnecting at one point. As a result, load flow analyses are required to confirm the impact to line capacities and voltage limits. Detailed load flow analyses will be performed as part of the project selection process. Prior to submitting a proposal, Proposers are encouraged to inquire about the viability of interconnecting a proposed Project at a specific location. Please direct questions to the RFP Email Address in Section 1.6.

- 2.2.1 A detailed IRS, when performed, may reveal other adverse system impacts that may further limit a Project’s ability to interconnect and/or further limit the net output of the Facility without upgrades.

---

<sup>9</sup> The ability to start itself and provide power to the Company's grid without relying on any services or energy from the Company's grid in order to assist the grid in recovering from a total or partial shutdown. During such a total or partial shutdown of the grid, the Project may experience step changes in load and other transient and dynamic conditions as it picks up load without support from other resources on the grid during start-up (if the Project remains connected) or while connecting to the loads the Project is picking up (not the start-up and connecting of the Facility itself).

## 2.3 Interconnection to the Company System

- 2.3.1 The Proposer must provide all information pertaining to the design, development, and construction of the Interconnection Facilities as specified in Appendix B. Interconnection Facilities includes both: (1) Seller-Owned Interconnection Facilities; and (2) Company-Owned Interconnection Facilities.
- 2.3.2 All Proposals must include a description and conceptual or schematic diagrams of the Proposer's plan to transmit power from the Facility to the Company System. The proposed Interconnection Facilities must be compatible with the Company System. In the design, Projects must adequately consider Company requirements to address impacts on the performance and reliability of the Company System.
- 2.3.2.1 In addition to the Performance Standards and findings of the IRS, the design of the Interconnection Facilities, including power rating, Point(s) of Interconnection with the Company System, and scheme of interconnection, must meet Company standards. The Company will provide its construction standards and procedures to the Proposer (Engineer, Procure, Construct Specifications for Hawaiian Electric Power Lines and Substations) if requested via the communication methods identified in Section 1.5 and upon the execution of a CBRE NDA as specified in Section 3.12.1. These specifications are intended to illustrate the scope of work typically required to administer and perform the design and construction of a Hawai'i Electric Light substation and power line.
- 2.3.2.2 Interconnection Facilities must be designed such that it meets or exceeds the applicable single line diagram in Appendix H, Attachment 1 or Attachment 2.
- 2.3.3 Tariff Rule No. 19, a copy of which is attached as Appendix I, establishes provisions for Interconnection and Transmission Upgrades. The tariff provisions are intended to simplify the rules regarding who pays for, installs, owns, and operates interconnection facilities in the context of competitive bidding.
- 2.3.4 The Proposer shall be responsible for all costs required to interconnect a Project to the Company System, including all Seller-Owned Interconnection Facilities and Company-Owned Interconnection Facilities.
- 2.3.5 Proposers are required to include in their pricing proposal all costs for interconnection and equipment expected to be required between their Facility and their proposed Point of Interconnection. Appendix H includes information related to Company-Owned Interconnection Facilities and costs that may be helpful to Proposers. Selected Proposers shall be responsible for the actual final costs of all Seller-Owned Interconnection Facilities and Company-Owned Interconnection Facilities (see Appendix H), whether or not such costs exceed the costs set forth in a Proposer's Proposal. No adjustments will be allowed to the proposed price in a Proposal if actual costs for Interconnection Facilities exceed the amounts proposed.
- 2.3.6 Proposers are required to include in their pricing proposal all costs for distribution-level service interconnection for station power.



2.3.7 All Projects will be screened for general readiness to comply with the requirements for interconnection. Proposals selected to the Final Award Group will be subject to Section 5.1.1. Proposals selected to the Final Award Group may be subject to further study in the form of an IRS. The IRS process is further described in Section 5.1.2. The results of the completed IRS or as identified through the Detailed Evaluation process, as well as any mitigation measures identified, will be incorporated into the terms and conditions of a final executed RDG PPA or Mid-Tier SFC.

**Chapter 3: Instructions to Proposers**

**3.1 Schedule for the Proposal Process**

Table 1 sets forth the proposed schedule for the proposal process (the “RFP Schedule”). The RFP Schedule is subject to PUC approval. The Company reserves the right to revise the RFP Schedule as necessary. Changes to the RFP Schedule prior to the RFP Proposal Due Date will be posted to the RFP website. Changes to the RFP Schedule after the Proposal Due Date will be communicated via Email to the Proposers and posted on the RFP Website.

**Table 1  
Proposed RFP Schedule**

<b>Milestone</b>	<b>Schedule Dates</b>
(1) Draft RFP filed	October 9, 2020
(2) Technical Status Conference	October 28, 2020
(3) Parties and Participants file Comments by	November 13, 2020
(4) Proposed Final RFP filed	December 1, 2020
(5) Final RFP is Issued	January 8, 2021 <sup>10</sup>
(6) Self-Build Proposal Due Date	March 9, 2021 at 2:00 pm HST
(7) IPP and Affiliate Proposal Due Date	March 10, 2021 at 2:00 pm HST
(8) Selection of Priority List	May 21, 2021
(9) BAFOs Due	May 28, 2021
(10) Selection of Final Award Group	September 10 , 2021
(11) Contract Negotiations Start	September 20, 2021

**3.2 Company RFP Website/Electronic Procurement Platform**

3.2.1 The Company has established a website for general information to share with potential Proposers. The RFP website is located at the following link:

---

<sup>10</sup> Per Section IV.B.6.e.ii of the Competitive Bidding Framework “[t]he utility shall have the right to issue the RFP if the Commission does not direct the utility to do otherwise within thirty (30) days after the Commission receives the proposed RFP and the Independent Observer's comments and recommendations.” January 8, 2021 is an offered issue date that provides the Commission at least thirty (30) days to review the Proposed Final RFP drafts but shifts the Proposal development period to begin after the holiday season. However, this date and all subsequent dates in the proposed schedule are dependent on any further guidance provided by the PUC.

[www.hawaiianelectric.com/competitivebidding](http://www.hawaiianelectric.com/competitivebidding)

The Company will provide general notices, updates, schedules and other information on the RFP website throughout the process. Proposers should check the website frequently to stay abreast of any new developments. This website will also contain the link to the Electronic Procurement Platform employed by the Company for the receipt of Proposals.

“Sourcing Intelligence” developed by Power Advocate is the Electronic Procurement Platform that the Company has licensed and will utilize for the receipt of Proposals in this RFP. Proposers who do not already have an existing account with PowerAdvocate and who intend to submit a Proposal for this RFP will need to register as a “Supplier” with PowerAdvocate.

- 3.2.2 There are no license fees, costs, or usage fees to Proposers for the use of the Electronic Procurement Platform.

See Appendix D for user information on and screenshots of PowerAdvocate’s Sourcing Intelligence procurement platform.

### **3.3 Information Exchange**

The PUC conducted a Technical Status Conference on October 28, 2020 to discuss the draft RFP. Parties and Participants had the opportunity to submit comments on the draft RFP. The Company then revised the RFP after considering the comments received and filed a final RFP for PUC review and approval.

Additionally, the Company will hold a prerecorded webinar for CBRE Tranche 1 in accordance with the Competitive Bidding Framework for prospective Proposers to learn about the provisions and requirements of this RFP. This prerecorded webinar will be posted to the Company’s website within one week of the issuance of the final RFP.

Prospective Proposers may also submit written questions regarding the RFP to the RFP Email Address set forth in Section 1.6. The Company will endeavor to address all questions that will be helpful to prospective Proposers via a Q&A section on the RFP website.

Prospective Proposers should review the RFP Website’s Q&A section prior to submission of their Proposal. Duplicate questions will not be answered.

### **3.4 Preparation of Proposals**

- 3.4.1 Each Proposer shall be solely responsible for reviewing the RFP (including all attachments and links) and for thoroughly investigating and informing itself with respect to all matters pertinent to this RFP, the Proposer’s Proposal, and the Proposer’s anticipated performance under the applicable RDG PPA or Mid-Tier SFC. It is the Proposer’s responsibility to ensure it understands all requirements of the RFP, to seek clarification if the RFP’s requirements or Company’s request is not clear, and to ask for any confirmation of receipt of submission of information. Under Section 1.7.5, the

Proposer is solely responsible for all errors in its Proposal(s). The Company will not accept any explanation by a Proposer that it was incumbent on the Company to catch any error.

- 3.4.2 Proposers shall rely only on official information provided by the Company in this RFP when preparing their Proposal. The Company will rely only on the information included in the Proposals, and additional information solicited by the Company to Proposers in the format requested, to evaluate the Proposals received. Evaluation will be based on the stated information in this RFP and on information submitted by Proposers in response to this RFP. Proposals must clearly state all capabilities, functionality and characteristics of the Project; must clearly detail plans to be performed; must explain applicability of information; and must provide all referenced material if it is to be considered during the Proposal evaluation. Referencing previous RFP submissions or projects for support will not be considered. Proposers should not assume that any previous RFP decisions or preferences will also apply to this RFP.
- 3.4.3 Each Proposer shall be solely responsible for, and shall bear all of its costs incurred in the preparation of its Proposal and/or its participation in this RFP, including, but not limited to, all costs incurred with respect to the following: (1) review of the RFP documents; (2) status conference participation; (3) site visits; (4) third-party consultant consultation; and (5) investigation and research relating to its Proposal and this RFP. The Company will not reimburse any Proposer for any such costs, including the selected Proposer(s).
- 3.4.4 Each Proposal must contain the full name and business address of the Proposer and must be signed by an authorized officer or agent<sup>11</sup> of the Proposer.

### **3.5 Organization of the Proposal**

The Proposal must be organized as specified in Appendix B. It is the Proposer's responsibility to ensure the information requested in this RFP is submitted and contained within the defined proposal sections as specified in Appendix B.

### **3.6 Proposal Limitations**

Proposers expressly acknowledge that Proposals are submitted subject to the following limitations:

The RFP does not commit or require the Company to award a contract, pay any costs incurred by a Proposer in the preparation of a Proposal, or procure or contract for products or services of any kind whatsoever. The Company reserves the right, in consultation with the Independent Observer, to accept or reject, in whole or in part, any or all Proposals submitted in response to this RFP, to negotiate with any or all Proposers

---

<sup>11</sup> Proposer's officer or agent must be authorized to sign the Proposal. Such authorization must be in writing and may be granted via Proposer's organizational documents (i.e., Articles of Incorporation, Articles of Organization, By-laws, etc.), resolution, or similar documentation.

eligible to be selected for award, or to withdraw or modify this RFP in whole or in part at any time.

- The Company reserves the right, in consultation with the Independent Observer, to request additional information from any or all Proposers relating to their Proposals or to request that Proposers clarify the contents of their Proposals. Proposers who are not responsive to such information requests may be eliminated from further consideration upon consultation with the Independent Observer.
- The Company reserves the right, in consultation with the Independent Observer, to solicit additional Proposals from Proposers after reviewing the initial Proposals. Other than as provided in this RFP, no Proposer will be allowed to alter its Proposal or add new information to a Proposal after the Proposal Due Date.
- All material submitted in response to this RFP will become the sole property of the Company, subject to the terms of the CBRE NDA.

### **3.7 Proposal Compliance and Bases for Disqualification**

Proposers may be deemed non-responsive and/or Proposals may not be considered for reasons including, but not limited to, the following:

- Any unsolicited contact by a Proposer or prospective Proposer with personnel of the Company pertaining to this RFP as described in Section 1.5.5.
- Any illegal or undue attempts by or on behalf of the Proposer or others to influence the Proposal Review process.
- The Proposal does not meet one or more of the Eligibility Requirements specified in Section 4.2.
- The Proposal does not meet one or more of the Threshold Requirements specified in Section 4.3.
- The Proposal is deemed to be unacceptable through a fatal flaws analysis as described in Section 4.4.2.
- The Proposer does not respond to a Company request for additional information to clarify the contents of its Proposal within the timelines specified by the Company.
- The Proposal contains misrepresentations or errors.

### **3.8 Power Purchase Agreement**

- 3.8.1 The Power Purchase Agreement for proposals selected under this RFP that are greater than 2.5 MW in size will be in the form of the RDG PPA, attached as Appendix K and Appendix M.

- 3.8.2 The Power Purchase Agreement for proposals selected under this RFP that are 250 kW or larger, up to and including 2.5 MW in size, will be in the form of a pre-approved Mid-Tier SFC, attached as Appendix L and Appendix N. The Mid-Tier SFC will be reviewed and pre-approved by the PUC and as a result, will not be negotiable.
- 3.8.3 If selected, any Affiliate Proposers will be required to enter into the applicable RDG PPA or Mid-Tier SFC with the Company.
- 3.8.4 If selected, a Self-Build Proposer will not be required to enter into a RDG PPA or Mid-Tier SFC with the Company. However, the Self-Build Proposer will be held to the proposed modifications to the RDG PPA, if any, it submits as part of the SBO in accordance with Section 3.8.6. Moreover, the SBO will be held to the same performance metrics and milestones set forth in the applicable RDG PPA or Mid-Tier SFC to the same extent as all Proposers, as attested to in the SBO's Appendix G Attachment 1, Self-Build Option Certification submittal. If liquidated damages are assessed, they will be paid from shareholder funds and returned to customers through the Purchased Power Adjustment Clause ("PPAC") or other appropriate rate adjustment mechanisms.

To retain the benefits of operational flexibility for a Company-owned facility, the SBO Proposal will be permitted to adjust operational requirements and performance metrics with the approval of the PUC. The process for adjustment would be similar to a negotiated amendment to a PPA with PUC approval.

- 3.8.5 In general, under the RDG PPA and Mid-Tier SFC, payment to the Seller consists of a Lump Sum Payment component to cover the costs of the Project. For wind projects only, the Company will allow developers to also include an additional Price for Purchase of Electric/Renewable Energy component (\$/MWh component) to cover variable operations and maintenance costs that cannot be captured within the Lump Sum Payment component. In return for the Lump Sum Payment component, the Seller shall guarantee minimum performance and availability metrics to ensure that the Facility is maintained and available for energy storage (if applicable) and dispatch, as well as provide an indication of the available energy in near real-time for the Company's dispatch. Company shall not be obligated to accept, nor shall it be required to pay for, test energy generated by the Facility during acceptance testing or other test conditions.
- 3.8.6 The Performance Standards identified in Section 2.1 establish the minimum requirements a Proposal must satisfy to be eligible for consideration in this RFP. A proposed Facility's ability to meet these Performance Standards is both a Threshold Requirement and a Non-Price Related Criteria under Sections 4.3 and 4.4.2, respectively. As such, these Performance Standards are non-negotiable by a Self-Build Proposer or any other Proposer. Proposers may propose modifications to other sections of the RDG PPA but are encouraged to accept such terms as written in order to expedite the overall RFP process and potential contract negotiations. As a component of their respective Proposals, a Self-Build Proposer or any other Proposer who elects to propose modifications shall provide a Microsoft Word red-line version of the relevant document identifying specific proposed modifications to the model language that the Proposer is

agreeable to, as well as a detailed explanation and supporting rationale for each modification.

- 3.8.6.1 General comments, drafting notes and footnotes such as “parties to discuss,” and reservation of rights to propose modifications at a later time, are unacceptable and will be considered non-responsive. Proposed modifications to the RDG PPA will be evaluated as a non-price evaluation criterion as further described in Section 4.4.2. In order to facilitate this process, the Company will make available electronic versions of the model agreements on the RFP website and through the Electronic Procurement Platform for the RFP. Any proposed modifications to the RDG PPA will be subject to negotiation between the Company and the Final Award Group and should not be assumed to have been accepted either as a result of being selected to the Final Award Group or based on any previously executed PPA. As stated above, since general comments, drafting notes, and footnotes without accompanying specific proposed language modifications are unacceptable and non-responsive, the Company will not negotiate provisions simply marked by such general comments, drafting notes, and footnotes.
- 3.8.6.2 The Company has an interest in maintaining consistency for certain provisions of the RDG PPAs, such as the calculation of availability and payment terms. Therefore, for such provisions, the Company will endeavor to negotiate similar and consistent language across PPAs for the Final Award Group.
- 3.8.7 Proposals that do not include specific proposed modifications to the attached RDG PPAs will be deemed to have accepted the RDG PPA in its entirety.

### **3.9 Pricing Requirements**

- 3.9.1 Proposers must submit pricing for each of their variations associated with each Proposal (if variations as described in Section 1.8.2 and 1.8.3 are submitted). Proposers are responsible for understanding the terms of the applicable RDG PPA or Mid-Tier SFC. Pricing cannot be specified as contingent upon other factors (e.g., changes to federal tax policy or receiving all Investment Tax Credits assumed).
- 3.9.2 Escalation in pricing over the term of the RDG PPA or the term of the Mid-Tier SFC is prohibited.
- 3.9.3 Pricing information must only be identified within specified sections of the Proposal as instructed by this RFP’s Appendix B Proposer’s Response Package (i.e., Proposal pricing information must be contained within defined Proposal sections of the Proposal submission). Pricing information contained anywhere else in a Proposal will not be considered during the evaluation process.
- 3.9.4 The Proposer’s Response Package must include the following prices for each Proposal (and variation):

For IPP or Affiliate proposals:

- **Lump Sum Payment (\$/year):** Payment amount for full dispatchability of the Facility. Payment will be made in monthly increments.
- **(Optional, For Wind Projects Only) Price for Purchase of Electric/Renewable Energy (\$/MWh):** Payment for delivery of net energy sourced from the variable generation resource, if desired. No Energy Payment will be provided for any energy delivery that is sourced originally from the grid (Company’s System).

For Self-Build Proposals:

- **Total Project Capital Costs (\$/year):** Total capital costs for the project (identified by year).
- **Annual O&M Costs (\$/year):** Initial year operations and maintenance costs, annual escalation rate.
- **Annual Revenue Requirement (\$/year):** Annual revenue requirements (ARR) calculated for each year.

See Appendix G for descriptions and detail on the Total Project Capital Costs, Annual O&M Costs, and Annual Revenue Requirement for the Self-Build Proposals.

- 3.9.5 As identified in the Schedule of Defined Terms in the PPA under “BESS Allocated Portion of the Lump Sum Payment”, the allocated portion of the Lump Sum Payment specified for energy storage for the Facility for determining liquidated damages is 50% and shall be a non-negotiable percentage in the PPA.

### 3.10 Project Description

- 3.10.1 Proposals are required to provide a NEP RFP Projection for the Project. The NEP RFP Projection associated with the proposed Project represents the estimated annual net energy (in MWh) that could be produced by the Facility and delivered to the Point of Interconnection over a ten-year period with a probability of exceedance of 95%. For Paired Projects, the energy generated by the Facility in excess of Company dispatch but below the Facility’s Allowed Capacity that is stored in the Facility’s energy storage component and can later be discharged to the POI considering the BESS Contract Capacity and Maximum Rated Output should be included in the NEP RFP Projection. Any energy in excess of what is allowed to be delivered to the POI and would exceed the BESS Contract Capacity shall be excluded from the Net Energy Potential. To achieve this objective, the BESS Contract Capacity (MWh) must be at least four times the MW Capacity of the installed PV or wind Capacity. Any energy generated outside of the proposed Facility that is used to charge the energy storage component should not be factored into the NEP RFP Projection. Any losses that may be incurred from energy being stored and then discharged from the energy storage (round trip efficiency losses) should be excluded from the NEP RFP Projection, but the NEP should consider auxiliary loads in developing the value relative to the POI. The NEP RFP Projection will be used

in the RFP evaluation process and therefore Proposers will be held to their provided value.<sup>12</sup>

- 3.10.2 Paired Project Proposals are required to provide a single value Round Trip Efficiency (“RTE”), measured at the Point of Interconnection, that the Facility’s BESS component is required to maintain throughout the term of the RDG PPA or Mid-Tier SFC. This RTE value will be used in the RFP evaluation process and therefore Proposers will be held to this provided value as it will become the RTE Performance Metric in Section 2.10 of the RDG PPA or Mid-Tier SFC. Please review the model PPA for potential liquidated damages assessed against Seller if the BESS does not maintain the required RTE. The RTE is further specified in Appendix B Section 2.
- 3.10.3 Each Proposer must also agree to provide Project financial information, including proposed Project finance structure information specified in Appendix B. Such information will be used to evaluate Threshold Requirements and non-price criteria (e.g., Financial Viability of Proposer, Financial Strength and Financing Plan, State of Project Development and Schedule) set forth in Sections 4.3 and 4.4.2. Upon selection, the Final Award Group may be requested to provide further detailed cost information if requested by the PUC or the Consumer Advocate as part of the PPA approval process. If requested, such information would be provided to the PUC, Consumer Advocate, and Company pursuant to a protective order in the docket.
- 3.10.4 The Proposer agrees that no material changes or additions to the Facility from what is submitted in its Proposal will be made without the Proposer first having obtained prior written consent from the Company. Evaluation of all Proposals in this RFP is based on the information submitted in each Proposal at the Proposal Due Date. If any Proposer requests any Proposal information to be changed after that date, the Company, in consultation with the Independent Observer, and in consideration of whether the evaluation is affected, will determine whether the change is permitted.

### **3.11 Sites Identified by the Company**

- 3.11.1 As an alternative to a Site identified by the Proposer, the Company has identified potential Sites where landowners have expressed a willingness to negotiate a lease or purchase of the land to support a renewable energy project. These Sites were identified through a Land RFI. Proposers will be responsible for working directly with the landowner and must secure Site Control with such landowner prior to submitting a Proposal. Land RFI information is available to interested parties who sign the CBRE NDA. The Land RFI is further described in Appendix F.

---

<sup>12</sup> If a Proposal is selected to the Final Award Group and a RDG PPA or Mid-Tier SFC is executed between the Company and the Proposer, the NEP RFP Projection will be further evaluated at several steps throughout the process as set forth in the RDG PPA or Mid-Tier SFC, and adjustments to the Lump Sum Payment will be made accordingly. Additionally, because the Company will rely on an accurate representation of the NEP RFP Projection in the RFP evaluation, a one-time liquidated damage as described in the RDG PPA or Mid-Tier SFC will be assessed if the First NEP benchmark is less than the Proposer’s NEP RFP Projection. After the Facility has achieved commercial operations, the performance of the Facility will be assessed on a continuing basis against key metrics identified in the RDG PPA or Mid-Tier SFC. See Article 2 and Attachment U of the RDG PPA or the Mid-Tier SFC.



Proposers are not required to select a Site identified in the Land RFI and as noted above may propose any Site for a Project.

### **3.12 Confidentiality**

- 3.12.1 Each prospective Proposer must submit an executed CBRE NDA in the form attached as Appendix E by the Proposal Due Date specified in the RFP Schedule in Section 3.1, Table 1, Item 7. The form of the CBRE NDA is not negotiable. Information designated as confidential by the Company will be provided on a limited basis, and only those prospective Proposers who have submitted an executed CBRE NDA will be considered. NDAs that were fully executed for prior non-CBRE RFPs will not be accepted. Proposers must clearly identify all confidential information in their Proposals. However, Proposers should designate as confidential only those portions of their Proposals that genuinely warrant confidential treatment. The Company discourages the practice of marking every page of a Proposal as confidential. The Company will make reasonable efforts to protect any such information that is clearly marked as confidential. Consistent with the terms of the CBRE NDA, the Company reserves the right to share any information, even if marked confidential, to its agents, contractors, or the Independent Observer for the purpose of evaluating the Proposal and facilitating potential contract negotiations.
- 3.12.2 Proposers, in submitting any Proposal(s) to Company in response to this RFP, certify that such Proposer has not shared its Proposal(s), or any part thereof, with any other Proposer of a Proposal(s) responsive to this RFP.
- 3.12.3 The Company will request that the PUC issue a Protective Order to protect confidential information provided by Proposers to the Company and to be filed in a proceeding before the PUC. A copy of the Protective Order, once issued by the PUC, will be provided to Proposers. Proposers should be aware that the Company may be required to share certain confidential information contained in Proposals with the PUC, the State of Hawai‘i Department of Commerce and Consumer Affairs, Division of Consumer Advocacy, and the parties to any docket instituted by the PUC, provided that recipients of confidential information have first agreed in writing to abide by the terms of the Protective Order. Notwithstanding the foregoing, no Proposer will be provided with Proposals from any other Proposer, nor will Proposers be provided with any other information contained in such Proposals or provided by or with respect to any other Proposer.

### **3.13 Credit Requirements**

- 3.13.1 Proposers with whom the Company enters into an RDG PPA or Mid-Tier SFC must post Development Period Security and Operating Period Security in the form of an irrevocable standby letter of credit from a bank chartered in the United States as required and set forth in Article 14 of the RDG PPA or the Mid-Tier SFC. Cash, a parent guaranty, or other forms of security will not be accepted in lieu of the irrevocable standby letter of credit.

- 3.13.2 The Development Period Security and Operating Period Security identified in the RDG PPA or the Mid-Tier SFC are minimum requirements. Proposers shall not propose an amount lower than that set forth in the RDG PPA or the Mid-Tier SFC.
- 3.13.3 Each Proposer shall be required to provide a satisfactory irrevocable standby letter of credit in favor of the Company from a bank chartered in the United States to guarantee Proposer's payment of interconnection costs for all Company-Owned Interconnection Facilities in excess of the Total Estimated Interconnection Costs and/or all relocations costs in excess of Total Estimated Relocation Costs that are payable to Company as required and set forth in Attachment G to the RDG PPA or the Mid-Tier SFC.
- 3.13.4 Proposers may be required to provide an irrevocable standby letter of credit in favor of the Company from a bank chartered in the United States in lieu of the required Source Code Escrow in an amount and as required and set forth in Attachment B to the RDG PPA or Mid-Tier SFC.

## **Chapter 4: Evaluation Process and Evaluation Criteria**

### **4.1 Proposal Evaluation and Selection Process**

The Company will employ a multi-step evaluation process. Once the Proposals are received, the Proposals will be subject to a consistent and defined review, evaluation, and selection process. This Chapter provides a description of each step of the process, along with the requirements of Proposers at each step. Figure 1 sets forth the flowchart for the proposal evaluation and selection process.

Upon receipt of the Proposals, the Company will review each Proposal submission to determine if it meets the Eligibility Requirements and the Threshold Requirements. The Company, in coordination with the Independent Observer will determine if a Proposer is allowed to cure any aspect of its Proposal or whether the Proposal would be eliminated based on failure to meet either Eligibility or Threshold Requirements.<sup>13</sup> If a Proposer is provided the opportunity to cure any aspect of its Proposal, the Proposer shall be given three (3) business days to cure from the date of notification to cure.<sup>14</sup> Proposals that have successfully met the Eligibility and Threshold Requirements will then enter a two-phase process for Proposal evaluation, which includes the Initial Evaluation resulting in the development of a Priority List, followed by the opportunity for Priority List Proposals to provide Best and Final Offers, and then a Detailed Evaluation process to arrive at a Final Award Group.

---

<sup>13</sup> As a general rule, if a Proposer does not include a requested document, inadvertently excludes minor information or provides inconsistencies in its information, it may be given a chance to cure such deficiency. If a Proposer fails to provide material required information in its Proposal and providing the Proposer an opportunity to cure is deemed by the Company, in consultation with the Independent Observer, as an unfair advantage to such Proposer, the Proposal could be classified as non-conforming and eliminated for failure to meet the Eligibility Requirements.

<sup>14</sup> The initial request will be offered three (3) business days to cure. Succeeding inquiries on the deficiencies will be offered cure periods deemed sufficient by the Company and Independent Observer.

**Figure 1 – Evaluation Workflow**

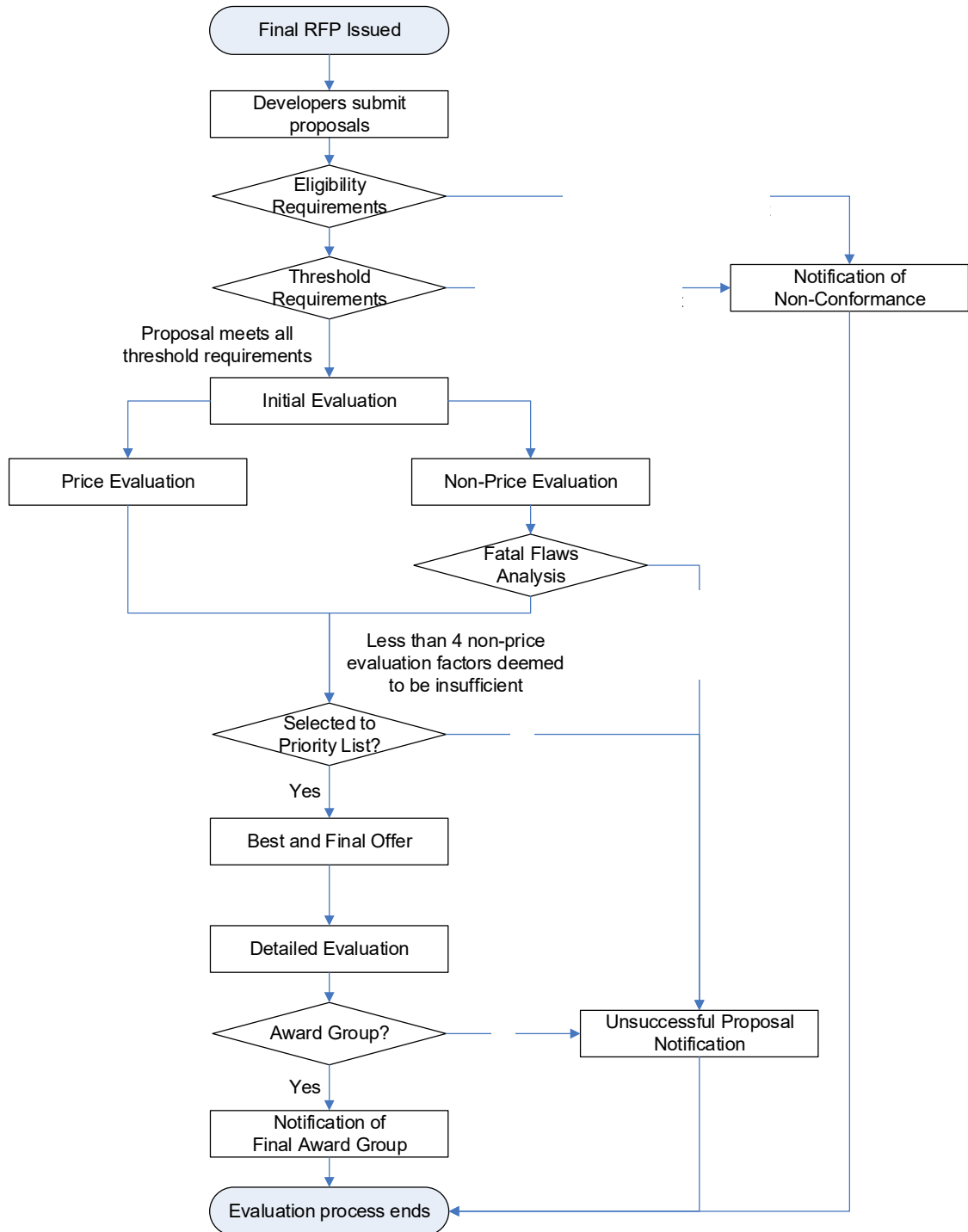

## 4.2 Eligibility Requirements Assessment

Upon receipt of the Proposals, each Proposal will be reviewed to ensure that it meets the following Eligibility Requirements.

- The Proposer is not eligible to participate in this RFP if the Proposer, its parent company, or an affiliate of the Proposer has:
  - defaulted on a current contract with the Company, or
  - had a contract terminated by the Company, or
  - any pending litigation with the Company.
- The Proposal including required uploaded files must be received on time via the Electronic Procurement Platform.
- The Proposal Fee must be received on or before the Proposal Due Date.<sup>15</sup>
- The Proposal must not contain material omissions.
- The Proposal must be signed and certified by an officer or other authorized person of the Proposer.
- The Proposer must fully execute the CBRE NDA and any other document required pursuant to this RFP.
- The Proposer must provide a Certificate of Vendor Compliance from the Hawai'i Compliance Express dated and issued within 60 days of the date of Proposal submission (a certificate of good standing from the State of Hawai'i Department of Commerce and Consumer Affairs and also federal and Hawai'i state tax clearance certificates for the Proposer may be substituted for the Certificate of Vendor Compliance).
- The Proposal must not be contingent upon changes to existing county, state, or federal laws or regulations.
- The proposed Project must be located on the island of Hawai'i.
- The proposed project must be 250 kW or larger.
- Projects interconnecting to a distribution circuit (12 kV or lower) must not exceed 3 MW.
- A minimum of 40% of the Subscriber portion of the Project must be dedicated to residential Subscribers as described in Section 1.2.3.
- Project infrastructure and point of interconnection must be located outside the 3.2 feet sea level rise exposure area (SLR-XA) as described in the Hawai'i Sea Level Rise Vulnerability and Adaptation Report (2017), and not located within a Tsunami Evacuation Zone.
- The Proposal must specify a GCOD no later than March 31, 2026.
- Proposers shall agree to post Development Period Security and Operating Period Security as described in Section 3.13.

## 4.3 Threshold Requirement Assessment

Proposals that meet all the Eligibility Requirements will then be evaluated to determine compliance with the Threshold Requirements, which have been designed to screen out Proposals

---

<sup>15</sup> Proposal Fees will not be required for SBO Proposals.

that are insufficiently developed, lack demonstrated technology, or will impose unacceptable execution risk for the Company.

Proposals must provide explanations and contain supporting information demonstrating how and why the Project proposed meets each of the Threshold Requirements. Proposals that fail to provide this information or meet a Threshold Requirement will be eliminated from further consideration upon concurrence with the Independent Observer.

The Threshold Requirements for this RFP are the following:

1. **Site Control:** The Proposal must demonstrate that the Proposer has Site Control for all real property required for the successful implementation of a specific Proposal at a Site not controlled by the Company, including any Interconnection Facilities, with the exception of right-of-way or easements for the interconnection route, for which the Proposer is responsible. The need for a firm commitment is necessary to ensure that Proposals are indeed realistic and can be relied upon as the Company moves through the remainder of the RFP process. As noted in Attachment B, Section 2.5.4, while land rights are not required with the Proposal for the interconnection route, the Proposal should thoroughly describe the interconnection route and as set forth in Attachment B, Section 2.5.5, the Proposal should identify any rights-of-way or easements that are required for access to the Site or for the interconnection route and describe the plan for obtaining such rights-of-way or easement, including the proposed timeline. In addition, developmental requirements and restrictions such as zoning of the Site and the status of easements must be identified and will be considered in determining whether the Proposal meets the Site Control threshold.

To meet this Site Control requirement, Proposers must do one of the following:

- Provide documentation confirming (1) that the Proposer has an existing legally enforceable right to use and control the Site, either in fee simple or under leasehold for a term at least equal to the term of the RDG PPA or Mid-Tier SFC (“Site Control”) as specified in the Proposer’s Proposal (taking into account the timelines set forth in this RFP for selection, negotiation, and execution of a RDG PPA or Mid-Tier SFC and PUC approval as applicable), and (2) the applicable zoning for the Site and that such zoning does not prohibit the development of the Site consistent with the Proposal; or
- Provide documentation confirming, at a minimum, (1) that the Proposer has an executed binding letter of intent, memorandum of understanding, option agreement, or similar document with the land owner (a “binding commitment”) which sets forth the general terms of a transaction that would grant the Proposer the required Site Control, and (2) the applicable zoning for the Site and that such zoning does not prohibit the development of the Site consistent with the Proposal. The binding commitment does not need to be exclusive to the Proposer at the time the Proposal is submitted and may be contingent upon selection of the Proposal to the Final Award Group. If multiple Projects are provided a binding commitment for the same Site, the

documents granting the binding commitments must not prevent the Company from choosing the Proposal that otherwise would have been selected.

- **Government/Public Lands Only:** The above two bullet points may not be feasible where government or publicly-owned lands are part of the Site or are required for the successful implementation of the Proposal. In such a case, at a minimum the Proposer must provide a credible and viable plan, including evidence of any steps taken to date, to secure all necessary Site Control for the Proposal, including but not limited to evidence of sufficient progress toward approval by the government agency or other body vested with the authority to grant such approval (as demonstrated by records of the agency). The Proposer will still be required, however, to demonstrate Site Control as required in the applicable RDG PPA or Mid-Tier SFC should the Proposal be selected to the Final Award Group.
2. **Performance Standards:** The proposed Facility must be able to meet the performance attributes identified in this RFP and the Performance Standards identified in Section 2.1 of this RFP. Proposals should include sufficient documentation to support the stated claim that the Facility will be able to meet the Performance Standards. The Proposal should include information required to make such a determination in an organized manner to ensure this evaluation can be completed within the evaluation review period.
  3. **Proven Technology:** This criterion is intended as a check to ensure that the technology proposed is viable and can reasonably be relied upon to meet the objectives of this RFP. The Company will only consider Proposals utilizing technologies that have successfully reached commercial operations in commercial applications (i.e., a PPA) at the scale being proposed. Proposals should include any supporting information for the Company to assess the commercial and financial maturity of the technology being proposed.
  4. **Experience of the Proposer:** The Proposer, its affiliated companies, partners, and/or contractors and consultants on the Proposer's Project team must have experience in financing, designing, constructing, interconnecting, owning, operating, and maintaining at least one (1) electricity generation project, including all components of the project (i.e., storage or other attributes), similar in size, scope, technology, and structure to the Project being proposed by Proposer. The Company will consider a Proposer to have reasonably met this Threshold Requirement if the Proposer can provide sufficient information in its Proposal's RFP Appendix B Section 2.13 tables demonstrating that at least one member of the Proposer's team (identified in the Proposal) has specific experience in each of the following categories: financing, designing, constructing, interconnecting, owning, operating, and maintaining projects similar to the Project being proposed.
  5. **Financial Compliance:** The proposed Project must not cause the Company to be subject to consolidation, as set forth in Financial Accounting Standards Board ("FASB") Accounting Standards Codification Topic 810, Consolidation ("ASC

810”), as issued and amended from time to time by FASB. Proposers are required to state to the best of their knowledge, with supporting information to allow the Company to verify such conclusion, that the Proposal will not result in the Seller under the PPA being a Variable Interest Entity (“VIE”) and result in the Company being the primary beneficiary of the Seller that would trigger consolidation of the Seller’s finances on to the Company’s financial statements under FASB ASC 810. The Company will perform a preliminary consolidation assessment based on the Proposals received. The Company reserves the right to allow a Proposal to proceed through the evaluation process through selection of the Priority List and work with the Proposer on this issue prior to or during PPA negotiations. The Company has determined that for purposes of FASB ASC 842, a generation plus storage facility will be treated as two separate measurements of account. For accounting purposes, the energy storage portion (if applicable) will be treated as a lease, while the generation facility will not. As a result, no lease evaluation will be completed as part of the Proposal evaluation.

6. **Community Outreach:** Gaining community support is an important part of a Project’s viability and success. A comprehensive community outreach and communications plan (“Community Outreach Plan”) is an essential roadmap that guides a developer as they work with various communities and stakeholders to gain their support for a Project. Proposers must include a Community Outreach Plan that describes the Proposer’s commitment to work with the neighboring community and stakeholders and to provide them timely Project information during all phases of the Project. The Community Outreach Plan shall include, but not be limited to, the following information: Project description, community scoping (including stakeholders and community concerns), Project benefits, government approvals, development process (including Project schedule), and a comprehensive communications plan.
7. **Cultural Resource Impacts:** Proposers need to be mindful of the Project’s potential impacts to historical and cultural resources. Proposers must identify: (1) valued cultural, historical, or natural resources in the area in question, including the extent to which traditional and customary native Hawaiian rights are exercised in the area; (2) the extent to which those resources – including traditional and customary native Hawaiian rights – will be affected or impaired by the proposed action; and (3) the feasible action, if any, to be taken to reasonably protect any identified cultural, historical, or natural resources in the area in question, and the reasonable protection of traditional and customary native Hawaiian rights in the affected area. Also, Proposers must have already contracted with a consultant with expertise in this field to begin a cultural impact assessment for the Project.

#### 4.4 Initial Evaluation – Price and Non-Price Analysis

Proposals that meet both the Eligibility and Threshold Requirements are Eligible Proposals which will then be subject to a price and non-price assessment. Two teams have been established to undertake the Proposal evaluation process: a Price Evaluation

Team and Non-Price Evaluation Team. The results of the price and non-price analysis will be a relative ranking and scoring of all Eligible Proposals. Price-related criteria will account for fifty-one percent (51%) of the total score and non-price-related criteria will account for forty-nine percent (49%) of the total score. The non-price criteria and methodology for applying the criteria are explained in Section 4.4.2.

The Company will employ a closed-bidding process for this solicitation in accordance with Part IV.H.3 of the Framework where the price and non-price evaluation models to be used will not be provided to Proposers. However, the Company will provide the Independent Observer with all necessary information to allow the Independent Observer to understand the evaluation models and to enable the Independent Observer to observe the entire analysis to ensure a fair process.

#### 4.4.1 Initial Evaluation of the Price Related Criteria

For the initial price analysis, an avoided cost screening approach will be used to rank proposals. Using the forecast and planning assumptions developed for the Company's Integrated Grid Planning process and evaluation methodology proposed in the Solution Evaluation & Optimization Working Group, a resource portfolio will be developed using a capacity expansion model to identify proxy resources that serve the grid needs and inform their marginal avoided costs. For each Proposal, the avoided cost of each grid service would be multiplied by the expected ability of the Proposal to provide that service or others, and summed across the services to determine the potential benefit of the Proposal. The benefit would then be reduced by the Proposal cost and normalized by the Net Energy Potential ("NEP") provided in the Proposal to calculate a Levelized Benefit ("LB") (\$/MWh).

The Company will conduct the comparative evaluation and award evaluation points to Proposals in accordance with the relative ranking based on LB. The Eligible Proposal with the highest LB will receive 510 points. All other Eligible Proposals will receive points based on a proportionate reduction using the percentage by which the Eligible Proposal's LB is lower than the highest LB. For example, if a Proposal's LB is ten percent (10%) lower than the highest LB, the Proposal will be awarded 459 points (that is, 510 points less 10%). The result of this assessment will be a ranking and scoring of the Proposals.

#### 4.4.2 Initial Evaluation of the Non-Price Related Criteria

For the non-price analysis, each Proposal will be evaluated on each of the twelve (12) non-price criteria categories set forth below:

1. Community Outreach
2. State of Project Development and Schedule
3. Performance Standards
4. Locational Value: Non-Wires Alternative (NWA) and Community Resilience
5. Commitment to Residential Subscriber Participation
6. CBRE Program
7. Environmental Compliance and Permitting Plan



8. Experience and Qualifications
9. Financial Strength and Financing Plan
10. RDG PPA Contract Proposed Modifications
11. Guaranteed Commercial Operations Date
12. Cultural Resource Impacts

Each of the first six criteria – Community Outreach, State of Project Development and Schedule, Performance Standards, Locational Value: NWA and Community Resilience, Commitment to Residential Subscriber Participation, and CBRE Program – will be weighted twice as heavily as the others to reflect the impact these categories have to achieve a successful and timely procurement. The non-price criteria are generally scored on a scale of 1 (poor) to 5 (highly preferable). A score of 3 means that a Proposal meets the minimum standard for that criteria.

The total non-price score will be the sum of the scores for each of the individual non-price criteria. The Company will then award non-price evaluation points in accordance with the relative ranking of scores. The Proposal with the highest total non-price score will receive 490 points, and all other Proposals will receive points equal to the Proposal's score divided by the top score, multiplied by 490.

During the non-price criteria evaluation, a fatal flaws analysis will also be conducted such that any Proposal that is deemed not to meet the minimum standards level for four (4) or more non-price criteria will be disqualified given that the Proposal has failed to meet the required number of non-price factors that are indicative as to the general feasibility and operational viability of a proposed Project. Non-price criteria number 4, 5 and 11 above will be excluded from the fatal flaws analysis.

The Company's evaluation of the non-price criteria will be based on the materials provided by a Proposer in its Proposal. Acceptance of any Proposal into the Final Award Group shall not be assumed or construed to be an endorsement or approval that the materials provided by Proposer are complete, accurate or in compliance with applicable law. The Company assumes no obligation to correct, confirm, or further research any of the materials submitted by Proposers. Proposers retain sole responsibility to ensure their Proposals are accurate and in compliance with all laws.

The non-price criteria are:

1. **Community Outreach** – Gaining community support is an important part of a Project's viability and success. An effective Community Outreach Plan will call for early meaningful communications with stakeholders and will reflect a deep understanding and respect for the community's desire for information to enable them to make informed decisions about future projects in their communities. Therefore, Proposals will be evaluated on the quality of the Community Outreach Plan to inform the Project's impacted communities.

Proposals should include a Community Outreach Plan that describes the Proposer's commitment to work with the neighboring community and

stakeholders and to provide timely Project information during Project development, construction and operation. The Community Outreach Plan shall include, but not be limited to the following:

- 1) Project description. A thorough description including a map of the location of the Project. This information will help the community understand the impact that the Project may have on the community.
- 2) Community scoping. Identify stakeholders (individuals, community leaders, organizations), community issues and concerns, and community sentiment.
- 3) Project benefits. An explanation of the need for the Project. This will help the community to understand how the Project might benefit their community.
- 4) Government approvals. Required government permits and approvals, public hearings and other opportunities for public comment. This information will help the community to understand the level of public scrutiny and participation that might occur for the Project and the opportunities to provide public comments.
- 5) Development process. A Project schedule that identifies key milestones will facilitate the community's understanding of the development process.
- 6) Communications Plan. A communications plan including a detailed community outreach schedule that will keep the affected communities and stakeholders informed about the Project's outreach efforts during early Project development period through construction and operations.

Preference will be given to Proposers who have already identified established contacts to work with the local community, have used community input to incorporate changes to the final design of the Project and mitigate community concerns, have proposed a community benefits package (including details of the community recipients and benefits package), or have community consultants as part of the Project team doing business in Hawai'i that have successfully worked with communities in Hawai'i on the development of two or more energy projects or projects with similar community issues. These criteria are aligned with the Company's community engagement expectation whereby all developers will be required to engage in community outreach prior to signing a PPA with the Company. This process is also outlined in RFP Section 5.3. Further information and instructions regarding expectations for the Community Outreach Plan are included as Attachment 4 and 5 to Appendix B.

2. **State of Project Development and Schedule** – Projects that are further along in development generally have lower project execution risk and a greater probability of being able to be successfully placed into service prior to the GCOD (specifically identified in each Proposal). At a minimum, Projects should demonstrate how they plan to capture any ITC safe harbor and reach their GCOD specified, including identification of risks and schedule assumptions. (Schedules must identify the IRS completion date and PUC approval dates assumed.) Proposals should also demonstrate, via a detailed critical path schedule, that there

is a high likelihood that the Project will be able to reach commercial operations as specified. Proposals shall include a Gantt chart that clearly illustrates the overall schedule and demonstrates achievement of any ITC safe harbor, if applicable, and commercial operations by their specified GCOD. The Gantt chart shall include task durations and dependencies, identify tasks that will be fast tracked, and identifies slack time and contingencies. This criterion will also look at the high-level Project costs set forth in the Proposal including: costs for equipment, construction, engineering, Seller-Owned Interconnection Facilities, Company-Owned Interconnection Facilities, land, annual O&M, the reasonableness of such costs and the assumptions used for such costs. Project costs that do not appear reasonable for a project of the size proposed may result in a lower ranking for this criterion if the Company reasonably determines that the cost information is unrealistic based on prior experience in the market which may result in a risk that the Project can be built on time and for the price proposed by the Proposer. The Company reserves the right to discuss any cost and financial information with a Proposer to ensure the information provided is accurate and correct.

3. **Performance Standards** – The proposed Facility must be able to meet the performance attributes identified in this RFP and the Performance Standards identified in the applicable RDG PPA or Mid-Tier SFC. The Company will review the Proposal information received, including design documents and operating procedures materials provided in the Proposal, and evaluate whether the Project as designed is able to meet the Performance Standards identified in the applicable RDG PPA or Mid-Tier SFC and in this RFP. At a minimum, in addition to meeting the Performance Standards, the Proposal should include sufficient documentation, provided in an organized manner, to support the stated claim that the Facility will be able to meet the Performance Standards. The Proposal should include information required to make such a determination in an organized manner to ensure this evaluation can be completed on a timely basis. Preference will be given to Proposals that provide detailed technical and design information showing how each standard can be met by the proposed Facility. Preference will also be provided on facilities that offer additional capabilities.
4. **Locational Value: Non-Wires Alternative and Community Resilience** – The Company has identified areas on the grid where the siting of a CBRE Project would support grid needs, non-wire alternatives and/or community resilience. Non-wires alternatives have been identified for areas with grid needs. For Projects that support non-wires alternatives, the capability to grid charge is needed to reliably meet distribution capacity needs. For Projects to support community resilience, storage with grid-forming and black start capability is needed for the purposes of being able to energize any proposed community or “island” as a microgrid from a de-energized state. The black start capability is not needed to energize the entire grid. Proposals should provide a description of the critical infrastructure or community resilience hubs in proximate location to the proposed Project site that could benefit from the islanding capabilities of the

proposed Project. Proposers are encouraged to and will be scored more favorably for locating projects in the following:

- Areas where the grid needs that are identified in Appendix O have a higher certainty rating. Distribution Grid Needs can also be found on the Company's Locational Value Map: [https://www.hawaiielectric.com/clean-energy-hawaii/integration-tools-and-resources/locational-value-maps/hawaii-island-locational-value-map-\(lvm\)](https://www.hawaiielectric.com/clean-energy-hawaii/integration-tools-and-resources/locational-value-maps/hawaii-island-locational-value-map-(lvm))
5. **Commitment to Residential Subscriber Participation** – Proposals will be evaluated on the stated commitments of the Project's Subscriber Organization to residential Subscribers. At a minimum, Subscriber Organizations will be required to set aside 40% of the Project's capacity for residential Subscribers. Proposers that commit to reserving a portion larger than 40% of their Project capacity for residential Subscribers will be given more favorable scoring. In addition, Proposals will also be evaluated on the stated commitments of the Project's Subscriber Organization to LMI Customers. Proposers that commit to reserving a portion of the Project's capacity for LMI Customers will be given more favorable scoring.
  6. **CBRE Program** – Proposals will be evaluated on several facets of the CBRE program being proposed.
    - 1) **Program Offering:** Proposals will be evaluated to give preference to program offerings that provide the most benefits to residential and LMI Customers, as applicable. Financing options, upfront fees, payment over time, public funding options, and other creative approaches will be preferred along with programs that offer higher expected customer level savings, favorable payback periods and mechanisms, and other customer benefits. In addition, Proposals shall describe the extent to which residential Subscribers will be financially responsible for the Facility's underperformance.
    - 2) **Marketing and Outreach Plans:** Proposals will be evaluated on the proposed strategies and methods to educate, inform, and stimulate the market in order to achieve their target levels of participation.
    - 3) **Program Experience:** Proposals will also be evaluated on Proposers documented success in reaching and retaining participation of residential and LMI Customers, as applicable, in other community-based renewable energy programs.
  7. **Environmental Compliance and Permitting Plan** – This criterion relates to the potential (short- and long-term) environmental impacts associated with each project, the quality of the plan offered by the Proposer to mitigate and manage

any environmental impacts (including any pre-existing environmental conditions), and the plan of Proposers to remain in environmental compliance over the term of the contract. These impacts are reflected on a technology-specific basis. Completing any necessary environmental review and obtaining the required permitting in a timely manner is also important and Proposals will be evaluated on their plan to identify, apply for, and secure the required permits for the Project, any permitting activity that has been completed to date, including having initial discussions with the applicable regulating agencies such as U.S. Fish and Wildlife and the State of Hawai'i Department of Land and Natural Resources' Division of Forestry and Wildlife, prior to submitting a Proposal, and the degree of certainty offered by the Proposer in securing the necessary permits.

At a minimum, proposed Projects should be expected to have minimal environmental impact for most areas and Proposals should provide a comprehensive plan to mitigate the identified potential or actual significant environmental impacts to remain in environmental compliance. The proposed mitigation plans should be included in the Project timeline. Preference will be given to Proposals that provide a more detailed plan as well as those that have proactively taken steps to mitigate potential environmental impacts.

Also, this criterion requires that, at a minimum, Proposers should have identified, and disclosed in their Proposal(s) all major permits, approvals, appurtenances and entitlements (including applicable access, rights of way and/or easements) (collectively, the "permits") required and have a preliminary plan for securing such permits. Preference will be given to Proposals that are able to provide a greater degree of certainty that its plan to secure the required permits is realistic and achievable, or have already received all or a majority of the required permits. The Proposer should disclose all identified (a) discretionary permits required, i.e., those requiring public or contested case hearings and/or review and discretionary approval by an appropriate government agency and (b) ministerial conditions without discretionary approval conditions. In all cases, the Proposer must provide a credible and viable plan to secure all necessary and appropriate permits necessary for the project. For example, if the project is located within an agricultural district, the Proposer shall provide evidence of Proposer's verification with the appropriate government agency that the project complies with HRS Section 205-2 and Section 205-4.5, relating to solar energy facilities placed on agricultural land, provided, however that where a special use permit (under Section 205-6), exemption (under Section 205-6), or amendment to land use district boundary lines (under Section 205-4) is required to secure such compliance, Proposer shall identify the need for such permit, exemption or amendment and provide a list of required prerequisites and/or conditions and a realistic timeline necessary to obtain such permit, exemption or amendment satisfactory for Proposer to still meet its designated Guaranteed Commercial Operations Date.

8. **Experience and Qualifications** – Proposals will be evaluated based on the experience of the Proposer in financing, designing, constructing, interconnecting, owning, operating, and maintaining projects (including all components of the project) of similar size, scope and technology. At a minimum, Proposals must show via the table format specified in RFP Appendix B Section 2.13 that at least one (1) member must have specific experience in each of the following categories: financing, designing, constructing, interconnecting, owning, operating, and maintaining at least one electricity generation project including all components of the project similar to the Project being proposed. Preference will be given to Proposers with experience in successfully developing multiple projects that are similar to the one being proposed and/or that have prior experience successfully developing and interconnecting a utility scale project to the Company's System.
  
9. **Financial Strength and Financing Plan** – This criterion addresses the comprehensiveness and reasonableness of the financial plan for the Project as well as assesses the financial strength and capability of the Proposer to develop the Project. A complete financial plan addresses the following issues: Project ownership, capital cost and capital structure, sources of debt and equity, and evidence that credit-worthy entities are interested in financing the Project. The financial strength of Proposers or their credit support providers will be considered, including their credit ratings. The financing participants are expected to be reasonably strong financially. Developers and their sources of capital that have investment grade credit ratings from a reputable credit rating agency (S&P, Moody's, Fitch) will also be given preference, with those that have higher credit ratings ranked higher.
  
10. **RDG PPA Contract Proposed Modifications** – Proposers are encouraged to accept the contract terms identified in the model RDG PPA in its entirety in order to expedite the overall RFP process and potential contract negotiations. Proposers who accept the model RDG PPA without edits or utilize the Mid-Tier SFC, which is non-negotiable and cannot be marked up as part of their Proposal, will receive a higher score and will be the only proposals that can achieve the highest scoring for this non-price evaluation criterion. Technology-specific or operating characteristic-required modifications, with adequate explanation as to the necessity of such modifications, will not jeopardize a project's ability to achieve the highest score. Proposers who elect to propose modifications to the model agreements shall provide a Microsoft Word red-line version of the applicable document identifying specific proposed modifications to the model agreement language, as well as a detailed explanation and supporting rationale for each modification. General comments without proposed alternate language, drafting notes without explanation or alternate language, footnotes such as "parties to discuss," or a reservation of rights to make additional modifications to the model agreements at a later time are unacceptable, will be considered unresponsive, and will result in a lower score. See also Section 3.8. The Company and Independent

Observer will evaluate the impact that the proposed modifications will have on the overall risk assessment associated with the evaluation of each Proposal.

11. **Guaranteed Commercial Operations Date** – Proposers that are able to design for and commit to an earlier GCOD will be given more favorable scoring. Proposers will be held to the GCOD identified in their Proposal. The GCOD will be a Guaranteed Milestone and will be inserted without amendment into the RDG PPA or Mid-Tier SFC, as applicable.
12. **Cultural Resource Impacts** – Proposers need to be mindful of the Project’s potential impacts to historical and cultural resources. Proposers should have identified (1) valued cultural, historical, or natural resources in the area in question, including the extent to which traditional and customary native Hawaiian rights are exercised in the area; (2) the extent to which those resources – including traditional and customary native Hawaiian rights – will be affected or impaired by the proposed action; and (3) the feasible action, if any, to be taken to reasonably protect any identified cultural, historical, or natural resources in the area in question, and the reasonable protection of traditional and customary native Hawaiian rights in the affected area.

Also, Proposers should have already contracted with a consultant with expertise in this field to begin a cultural impact assessment for the Project. Proposals will be evaluated on the Proposer’s plan and commitment to addressing cultural resource impacts on their Project, if any. Therefore, in order to be evaluated for this criterion, Proposers should, at least, provide the following documentation, as applicable: (1) Proposer’s or its consultant’s experience with cultural resource impacts on past projects; (2) the status of their cultural impact assessment plan. Proposals will be evaluated on the extent to which their cultural impact assessment plan has been developed, and preference will be given to Proposals that are further along in the assessment process, including but not limited to, whether a mitigation/action plan has been provided that addresses any identified cultural resource issues, or a date for when such a plan will be available has been identified, or any portions of such plan have been completed.

#### **4.5 Selection of a Priority List**

At the conclusion of both the price and non-price analysis, a total score will be calculated for each Proposal using the 51% price-related criteria / 49% non-price-related criteria weighting outlined above. The price and non-price analysis, and the summation of both price and non-price scores described above, will result in a ranking of Proposals.

The Company will determine a Priority List from the highest scoring Proposals. The Company will develop the Priority Lists in consultation with the Independent Observer. The Company reserves the right, in consultation with the Independent Observer, to limit the projects allowed for further consideration in the initial evaluation to projects that fall

within 15% of the highest Levelized Benefit. Selection to the Priority List does not assure an eligible Project's inclusion in the selection of the Final Award Group.

#### **4.6 Best and Final Offer (BAFO)**

4.6.1 The Company will solicit a Best and Final Offer from Proposers selected to the Priority List. If the SBO is selected to the Priority List, the SBO will not be eligible to provide a Best and Final Offer and the original pricing submitted in its Self-Build Proposal will be used in the Detailed Evaluation. All other Proposers selected to the Priority List will have the opportunity to update (downward only)<sup>16</sup> the pricing elements in their Proposal in order to improve the competitiveness of their Proposal prior to being further assessed in the Detailed Evaluation phase. At this point in the process, updates may only be made to the following pricing elements:

- Lump Sum Payment (\$/year) amount
- (For Wind Projects Only) Price for Purchase of Electric/Renewable Energy (\$/MWh) amount. Payment for delivery of net energy sourced from the variable generation resource. No Energy Payment will be provided for any energy delivery that is sourced originally from the grid (Company's System).

Proposers will not be allowed to increase their price<sup>17</sup> but may elect to maintain the same pricing submitted in their original Proposal. Proposers will not be allowed to make any other changes to their Proposal during the Best and Final Offer.

4.6.2 If a Proposer does not propose improvements to their pricing elements during the Best and Final Offer solicitation, the original Proposal pricing elements will be deemed its Best and Final Offer.<sup>18</sup>

#### **4.7 Detailed Evaluation**

The Best and Final Offers of the Priority List Proposals as well as any original Self-Build Proposals, if advanced to the Priority List, will be further assessed in the Detailed Evaluation to identify the Proposals selected to the Final Award Group.

The detailed evaluation process will consist of assessment of combinations of Proposals from the Priority List. A capacity expansion model will use the same assumptions as in the Initial Evaluation but replace the generic resource costs and performance characteristics with the specific costs and performance characteristics of the Projects. Due to computational limitations, all Proposals from the Priority List may not be

---

<sup>16</sup> Proposers will only be allowed to adjust pricing elements downward. No upward adjustment to the pricing elements will be permitted or considered. All other characteristics of the Proposal and Facility capabilities must remain valid and unchanged (e.g., NEP, GCOD, etc.)

<sup>17</sup> Proposers will not be allowed to increase the pricing in their Proposals to address interconnection and/or system upgrade costs or for any other reason.

<sup>18</sup> The Company reserves the right, in consultation with the Independent Observer, to adjust the parameters of the BAFO, in the unlikely event that system needs have evolved in a way that the Proposals received do not fully address.



evaluated simultaneously. The ranking developed in the Initial Evaluation can be used to screen the Proposals in the Detailed Evaluation to those that provide the highest potential benefit to the system. A production simulation model will then be used to provide a feasibility check on the final resource portfolio of Projects.

The evaluation will evaluate the benefits and costs of integrating the Project or combination of Projects onto the Company's System which includes:

1. The cost to dispatch the Project or combination of Projects and the energy and storage purchased;
2. The fuel cost savings (benefits) and any other direct savings (IPP savings from dispatchable fossil fuel savings, where applicable) resulting from the displacement of generation by the Priority List Proposals, including consideration of round-trip efficiencies for facilities with storage;
3. The estimated increase (or decrease) in operating cost, if any, incurred by the Company to maintain system reliability; and
4. The cost of imputed debt, if applicable.

As noted, the Company will take into account the cost of rebalancing its capital structure resulting from any debt or imputed debt impacts associated with each Proposal (including any costs to be incurred by the Company, as described above, that are necessary in implementing the Proposal). The Company proposes to use the imputed debt methodology published by S&P that is applicable to the Proposal being evaluated. S&P views long-term PPAs as creating fixed, debt-like financial obligations that represent substitutes for debt-financed capital investments in generation capacity. By adjusting financial measures to incorporate PPA-fixed obligations, greater comparability of utilities that finance and build generation capacity and those that purchase capacity to satisfy new load are achieved.

During the Detailed Evaluation and before the Proposals advance to the Final Award Group, the Company will perform load flow analyses to determine if certain Projects or combinations of Projects introduce circuit constraints that will factor into the selection process. This is to address the possibility that even though sufficient line capacity was identified for an individual Project, Projects that are in close proximity with each other could introduce additional circuit constraints. The Projects selected must not have any additional constraints imposed based on the Load Flow Analysis to advance to the Final Award Group. However, the Company reserves the right, in consultation with the Independent Observer, to allow minor modifications (i.e., downsize project) to a Proposal to avoid such additional constraints. If such modification resulted in a reduced size of the Facility, the pricing proposed would also need to be revised. Under no circumstances would a Proposer be allowed to increase their price as a result of such minor modification.

Also in the Detailed Evaluation, other factors will be validated to ensure that the final combination of Projects provides the contemplated benefits that the Company seeks. The

Company will evaluate the collateral consequences of the implementation of a combination of Projects, including consideration of the geographic diversity, resource diversity, interconnection complexity, and flexibility and latitude of operation control of the Projects.

The Company may assess additional combinations of Projects if requested by the Independent Observer and if the time and capability exist to perform such analyses.

Projects interconnecting to distribution circuits may be subject to the Technical Review process of Rule 14H. The Company may consider a Project's performance through this process in the Detailed Evaluation.

#### **4.8 Selection of the Final Award Group**

Based on the results of the Detailed Evaluation and review of the results with the Independent Observer, the Company will select a Final Award Group. Projects selected to the Final Award Group that are 250 kW or greater, up to and including 2.5 MW in size will execute a Mid-Tier SFC with the Company in the form of Appendix L or Appendix N. Projects larger than 2.5 MW will enter into RDG PPA (in the form of Appendix K or Appendix M) negotiations. All Proposers will be notified at this stage of the evaluation process whether their Proposal is included in the Final Award Group.

Selection to the Final Award Group and/or entering into contract negotiations does not guarantee execution of an RDG PPA or Mid-Tier SFC.

Further, if at any time during the evaluation process it is discovered that a Proposer's Proposal contains incorrect or misrepresented information that has a material effect on any of the evaluation processes, including selection of the Priority List or the Final Award Group, the Company reserves the right, at any time prior to submission of the PPA Application with the PUC, in consultation with the Independent Observer, to disqualify the Proposer from the RFP. If discovery of the incorrect or misrepresented information is made after the Company has filed its PUC application for approval of the PPA with the Proposer, the Company will disclose the incorrect or misrepresented information to the PUC for evaluation and decision as to whether such Proposer should be disqualified and the Company's application dismissed.

Following any removal of a proposal from the Final Award Group, either by disqualification noted immediately above, or via any other removal or withdrawal of a proposal, including failure to reach agreement to the PPA, the Company, taking into consideration the timing of such removal and the current status of the Company's needs under the RFP, in consultation with and concurrence from the Independent Observer, will review the Priority List to determine (1) if another proposal should be added to the Final Award Group; or (2) if the remaining proposals in the Final Award Group should remain unchanged.

## **Chapter 5: Post Evaluation Process**

### **5.1 Project Interconnection Process**

#### **5.1.1 Interconnection Modeling Process**

For all projects greater than or equal to 1 MW in size (regardless of whether an IRS is required), a complete package of Project Interconnection Data Request worksheets, Project single line diagram(s), models for equipment and controls, list(s) to clearly identify the components and respective files (for inverters and power plant controller), three line diagram(s) which show the Point of Interconnection, potential transformer (PT) and current transformer (CT) ratios, and details of the generating facility configuration, including relays, meters, and test switches, and complete documentation with instructions shall be submitted with each Proposal within 30 days after selection to the Final Award Group (see Section 2.11.1 of Appendix B). PSSE Generic models, PSSE User models, and ASPEN models shall be configured to represent all of the functional equipment with settings in place to comply with the Company's performance requirements. These must be checked for functionality by the Proposer or its vendors and consultants prior to submission to the Company. Similar and fully accurate PSCAD models shall be submitted in a condition that complies with the PSCAD modeling guidelines provided by the Company. Overlaid validation plots of PSSE Generic models, PSSE User models, and PSCAD models shall be submitted as described in the Project Interconnection Data Request worksheets to ensure compatible responses from each model.

If the Company determines that an IRS is not required, the Company will provide an Interconnection Modeling Letter Agreement for each selected Project greater than or equal to 1 MW in size, with a statement of required deposit for individual work for: (a) a technical model checkout for each project, and (b) any considerations that are specific to a particular project and location. After proposals and models are submitted, the Company will inspect the data packages for general completeness. For any incomplete submissions, a list of missing or non-functional items will be provided. Proposers will be given 15 Days to resolve data and modeling deficiencies. The Company, in consultation with the Independent Observer, may remove Proposals if their submission requirements are deemed incomplete for the lack of requested models and validation plots.

The technical model checkouts will be conducted first. Upon identification of any functional problems or deficiencies, corrective action shall be taken immediately and on an interactive basis so that the problems or deficiencies can be resolved within 15 Days, including re-submission of data and updated models, or the Project shall be deemed withdrawn. At the discretion of the Company and provided that there is a demonstration of good faith action to minimize delay that would affect the schedule, a second round of model checkout and problem solving may proceed. Thereafter, any notice that a Project is deemed withdrawn for lack of completeness shall be final. Subject to consultation with the Independent Observer, failure to provide all requested material within the time(s) specified, or changes to the data provided after the due date(s), shall result in elimination from consideration.

### 5.1.2 Interconnection Requirements Study Process

The Detailed Evaluation process or Appendix III of Rule 14H shall determine the need for an IRS. Upon notification of selection to the Final Award Group, and subject to Rule 14H, the Company will provide an IRS Letter Agreement (in lieu of an Interconnection Modeling Letter Agreement) for each selected project that will require an IRS, with a statement of required deposit for individual and prorated work as part of an IRS Scope for: (1) a System Impact Study that will involve (a) technical model checkout for each project, (b) any considerations that are specific to a particular project and location, and (c) system impact analyses of the projects as a group; and (2) a Facilities Study that includes the Interconnection cost and schedule, including cost of any required system upgrades. After proposals and models are submitted within 30 days after selection to the Final Award Group, the Company will inspect the data packages for general completeness. For any incomplete submissions, a list of missing or non-functional items will be provided. Proposers will be given 15 Days to resolve data and modeling deficiencies. The Company, in consultation with the Independent Observer, may remove Proposals if their submission requirements are deemed incomplete for the lack of requested models and validation plots.

The technical model checkouts will be conducted first. Upon identification of any functional problems or deficiencies, corrective action shall be taken immediately and on an interactive basis so that the problems or deficiencies can be resolved within 15 Days, including re-submission of data and updated models, or the Project shall be deemed withdrawn. At the discretion of the Company and provided that there is a demonstration of good faith action to minimize delay that would affect the schedule, a second round of model checkout and problem solving may proceed. Thereafter, any notice that a Project is deemed withdrawn for lack of completeness shall be final. Subject to consultation with the Independent Observer, failure to provide all requested material within the time(s) specified, or changes to the data provided after the due date(s), shall result in elimination from consideration.

Proposers shall be responsible for the cost of the IRS, under separate agreements for the System Impact Study and the Facilities Study. The overall IRS will provide information including, but not limited to, an estimated cost and schedule for the required Interconnection Facilities for a particular Project and any required mitigation measures. Proposers will be responsible for the actual final costs of all Seller-Owned Interconnection Facilities and Company-Owned Interconnection Facilities. Upon reviewing the results of the IRS, Detailed Evaluation or Technical Review process, if required, pursuant to Rule 14H, Appendix III, Proposers will have the opportunity to declare the RDG PPA (see Section 12.4) or Mid-Tier SFC null and void in the event that the estimated interconnection costs and schedule for the Project are higher than what was estimated in the Project Proposal.

## 5.2 Contract Negotiation Process

Within five (5) business days of being notified by the Company of its intent to enter into RDG PPA contract negotiations or execute a Mid-Tier SFC, Proposers selected for the

Final Award Group will be required to indicate, in writing to the Company's primary contact for this RFP, whether they intend to proceed with their Proposals. Proposers who elect to remain in the Final Award Group will be required to keep their Proposal valid through the award period. RDG PPA contract negotiations will take place in parallel with the IRS process.

The Company intends to execute and file the PPA with the PUC for approval and later amend the PPA to include the results of the IRS.

### **5.3 Community Outreach and Engagement**

The public meeting and comment solicitation process described in this section and Section 29.21 of the RDG PPA (Community Outreach Plan) and Section 28 of the Mid-Tier SFC (Community Outreach) do not represent the only community outreach and engagement activities that can or should be performed by a Proposer.

The Company will publicly announce the Final Award Group no more than five (5) business days after the notification is given to Proposers who are selected to the Final Award Group. Selected Proposers shall not disclose their selection to the public before the Company publicly announces the Final Award Group selection.

On the next business day after the Company notifies a Proposer they were selected, each Proposer shall provide the Company with links to their Project website, which the Company will post on the Company's website. Each Proposer will launch a Project website that will go-live on the day the Company publicly announces the Final Award Group selection. Information on what should be included on the Project website is identified in Appendix B.

Within five (5) business days of notification of selection to the Final Award Group, Proposers must provide the Company with an updated comprehensive Community Outreach Plan to work with and inform neighboring communities and stakeholders and to provide them timely information during all phases of the Project. The Community Outreach Plan shall include but not be limited to the following information: Project description, Project stakeholders, community concerns and Proposer's efforts to address such concerns, Project benefits, government approvals, Project schedule, and a comprehensive communications plan. The Proposer's Community Outreach Plan shall be a public document identified on the Proposer's Project website and made available to the public upon request. As an option, Proposers may provide their updated Community Outreach Plan and website information to the Company for review and feedback. If provided at least 30 days prior to the dates required, the Company will endeavor to review such information and provide feedback on the information before it is made available to the public. Details on the Community Outreach Plan can be found in Appendix B, Attachments 4 and 5.

Prior to the execution date of the PPA, Proposers shall also host a public meeting in the community where the proposed Project is to be located for community and neighborhood groups in and around the vicinity of the Project Site that provided the neighboring

community, stakeholders and the general public with: (i) a reasonable opportunity to learn about the proposed Project; (ii) an opportunity to engage in a dialogue about concerns, mitigation measures, and potential community benefits of the proposed Project; and (iii) information concerning the process and/or intent for the public's input and engagement, including advising attendees for projects greater than 2.5 MW in size that they will have thirty (30) calendar days from the date of said public meeting to submit written comments to Company and/or Proposer for inclusion in the Company's submission to the PUC of its application for a satisfactory PUC Approval Order for Projects greater than 2.5 MW and for inclusion on the Proposer's website for Projects up to and including 2.5 MW. The Proposer shall collect all public comments, and then provide the Company copies of all comments received in their original, unedited form. The Proposer will post all comments with personal information redacted on its website for public review. Comments should remain on the Proposer's website for at least two years after the Commercial Operations date. If an RDG PPA is executed by the Proposer and the Company, the Company may submit any and all public comments (presented in its original, unedited form) as part of its PUC application for this Project. Proposers shall notify the public at least three weeks in advance of the meeting. The Company shall be informed of the meeting. The Company has provided Proposers with detailed instructions regarding the community meeting requirement after the selection of the Final Award Group (Attachment 4 to Appendix B). (For example, notice will be published in county or regional newspapers/media, as well as media with statewide distribution. The Proposer will be directed to notify certain individuals and organizations. The Proposer will be provided templates to use for the public meeting notices, agenda, and presentation.) Proposers must also comply with any other requirement set forth in the RDG PPA or Mid-Tier SFC relating to Community Outreach.

Following the submission of the PUC application for the Project, and prior to the date when the Parties' statements of position are to be filed in the docketed PUC proceeding for the Project, the Proposer shall provide another opportunity for the public to comment on the proposed Project. The Proposer's statement of position filed in the docket associated with the Project will contain an attachment including those comments.

The Proposer shall be responsible for community outreach and engagement for the Project, and that the public meeting and comment solicitation process described in this section do not represent the only community outreach and engagement activities that can or should be performed.

#### **5.4 Greenhouse Gas Emissions Analysis**

Proposers whose Proposal(s) are selected for the Final Award Group and are greater than 2.5 MW in size shall cooperate with and promptly provide to the Company and/or Company's consultant(s) upon request all information necessary, in the Company's sole and exclusive discretion, for such consultant to prepare a greenhouse gas ("GHG") emissions analysis and report in support of a PUC application for approval of the RDG PPA for the Project (the "GHG Review"). Proposers shall be responsible for the full cost of the GHG Review associated with their Project under a Greenhouse Gas Analysis Letter Agreement between the Proposer and the Company. The GHG Review is

anticipated to address whether the GHG emissions that would result from approval of the RDG PPA and subsequent to addition of the Project to the Company's system are greater than the GHG emissions that would result from the operations of the Company's System without the addition of the Project, whether the cost for renewable, dispatchable generation, and/or energy storage services as applicable under the RDG PPA is reasonable in light of the potential for GHG emissions, and whether the terms of the RDG PPA are prudent and in the public interest in light of its potential hidden and long-term consequences.

## **5.5 PUC Approval**

Any signed RDG PPA resulting from this RFP, greater than 2.5 MW in size, is subject to PUC approval as described in the RDG PPA, including Article 12 and Section 29.20 thereof. Selected projects that are 250 kW or greater, up to and including 2.5 MW will execute a Mid-Tier SFC with the Company which will not be subject to further regulatory review and approval. Selected SBO proposals, greater than 2.5 MW in size are required to file application pursuant to General Order No. 7 if the requirements for such filing are met. However, SBO proposals that are 250 kW or greater, up to and including 2.5 MW will also not be required to submit an additional application pursuant to General Order No. 7, but the Commission will hold the bidding utility to the terms of its bid, similar to an independent power producer.

## **5.6 Facility In-Service**

In order to facilitate the timely commissioning of the projects selected through this RFP, the Company requires the following be included with the 60% design drawings: relay settings and protection coordination study, including fuse selection and ac/dc schematic trip scheme.

For the Company to test the Facility, coordination between the Company and Project is required. Drawings must be approved by the Company prior to testing. The entire Facility must be ready for testing to commence. Piecemeal testing will not be allowed. Communication infrastructure and equipment must be tested by the IPP and ready for operation prior to Company testing.

If approved drawings are not available, or if the Facility is otherwise not test ready as scheduled, the Project may lose its place in the queue, with the Company retaining the flexibility to adjust scheduling as it sees fit. If tests are not completed within the allotted scheduled testing time, the Project will be moved to the end of the Company's testing queue. The IPP will be allowed to cure if successful testing is completed within the allotted scheduled time. No adjustments will be made to RDG PPA or Mid-Tier SFC milestones if tests are not completed within the original allotted time. Liquidated damages for missed milestones will be assessed pursuant to the RDG PPA or Mid-Tier SFC.

**DRAFT**  
**REQUEST FOR PROPOSALS**  
**FOR**  
**COMMUNITY-BASED RENEWABLE ENERGY TRANCHE 1**  
**ISLAND OF HAWAI‘I**

DECEMBER 1, 2020

Docket No. 2015-0389

*Appendix A – Definitions*



**Hawai‘i**  
**Electric**  
**Light**



“Affiliate” means any person or entity that possesses an “affiliated interest” in a utility as defined by section 269-19.5, Hawaii Revised Statutes (“HRS”), including a utility’s parent holding company but excluding a utility’s subsidiary or parent which is also a regulated utility.

“Allowed Capacity” has the meaning set forth in the RDG PPA and Mid-Tier SFC.

“Best and Final Offer” or “BAFO” means the final offer from a Proposer, as further described in Section 4.6 and elsewhere in this RFP.

“CBRE NDA” means the Mutual Confidentiality and Non-Disclosure Agreement attached to this RFP as Appendix E.

“Code of Conduct” means the code of conduct approved by the PUC in Docket No. 03-0372 (Decision and Order No. 23614, August 28, 2007) with respect to a Self-Build Option. An updated code of conduct was submitted to the PUC in Docket No. 2015-0389 on July 9, 2020.

“Code of Conduct Procedures Manual” or “Procedures Manual” means the manual approved by the PUC, which was put in place to address and to safeguard against preferential treatment or preferential access to information in a Hawaiian Electric, Maui Electric, or Hawaii Electric Light RFP process. The Procedures Manual is attached as Appendix C to this RFP.

“Commercial Operations” has the meaning set forth in the RDG PPA and Mid-Tier SFC.

“Community Outreach Plan” is a community outreach and communication plan described in Section 4.3 and 4.4.2 of this RFP.

“Company” means Hawai‘i Electric Light Company, Inc.

“Company-Owned Interconnection Facilities” has the meaning set forth in the RDG PPA and Mid-Tier SFC.

“Competitive Bidding Framework” or “Framework” means the Framework for Competitive Bidding contained in Decision and Order No. 23121 issued by the Public Utilities Commission on December 8, 2006, and any subsequent orders providing for modifications from those set forth in Order No. 23121 issued December 8, 2006.

“Consumer Advocate” means the Division of Consumer Advocacy of the Department of Commerce and Consumer Affairs of the State of Hawai‘i.

“Day” means a calendar day, unless the term “business day” is used, which means calendar day excluding weekends and federal and State of Hawai‘i holidays.

“Development Period Security” has the meaning set forth in Section 14.2 of the RDG PPA and the Mid-Tier SFC.

“Dispatchable” means the ability to turn on or turn off a generating resource at the request of the utility’s system operators, or the ability to increase or decrease the output of a generating resource

from moment to moment in response to signals from a utility's Automatic Generation Control System, Energy Management System or similar control system, or at the request of the utility's system operators.

“Electronic Procurement Platform” means the third-party web-based sourcing platform that will be used for the intake of Proposals and associated electronic information, storage and handling of Proposer information, and communication.

“Eligibility Requirements” has the meaning set forth in Section 4.2 of this RFP.

“Eligible Proposals” means Proposals that meet both the Eligibility and Threshold Requirements.

“Energy Contract Manager” is the primary Company contact for this RFP.

“Evaluation Team” means agents of the Company who evaluate Proposals.

“Facility” has the meaning set forth in the RDG PPA and Mid-Tier SFC.

“Facilities Studies” means a study to develop the interconnection facilities cost and schedule estimate including the cost associated with the design and construction of the Company-owned interconnection facilities.

“Final Award Group” means the group of Proposers selected by the Company from the Priority List, with which the Company will begin contract negotiations, based on the results of the Company's detailed evaluation.

“Greenhouse Gas” or “GHG” are gases that contribute to the greenhouse gas effect and trap heat in the atmosphere.

“Guaranteed Commercial Operations Date” or “GCOD” means the date on which a Facility first achieves Commercial Operations.

“Hawai'i Electric Light” means Hawai'i Electric Light Company, Inc.

“Hawai'i Electric Light System” or “System” means the electric system owned and operated by Hawai'i Electric Light on the island of Hawai'i (including any non-utility owned facilities) consisting of power plants, transmission and distribution lines, and related equipment for the production and delivery of electric power to the public.

“Hawaiian Electric” means Hawaiian Electric Company, Inc., a Hawai'i corporation.

“Hawaiian Electric Companies” or “Companies” means Hawaiian Electric Company, Inc. and its subsidiaries, Hawaii Electric Light Company, Inc. and Maui Electric Company, Limited.

“HRS” means the Hawai'i Revised Statutes as of the date of this Request for Proposals.

“Imputed Debt” means adjustments to the debt amounts reported on financial statements prepared under generally accepted accounting principles (“GAAP”). Certain obligations do not

meet the GAAP criteria of “debt” but have debt-like characteristics; therefore, credit rating agencies “impute debt and interest” in evaluating the financial ratios of a company.

“Independent Observer” has the meaning set forth in Section 1.4 of this RFP.

“Independent Power Producer” or “IPP” means an entity that owns or operates an electricity generating facility that is not included in the Company’s rate base.

“Interconnection Facilities” means the equipment and devices required to permit a Facility to operate in parallel with, and deliver electric energy to, the Company System (in accordance with applicable provisions of the Commission’s General Order No. 7, Company tariffs, operational practices, interconnection requirements studies, and planning criteria), such as, but not limited to, transmission and distribution lines, transformers, switches, and circuit breakers. Interconnection Facilities includes Company-Owned Interconnection Facilities and Seller-Owned Interconnection Facilities.

“Interconnection Requirements Study” or “IRS” means a study, performed in accordance with the terms of the IRS Letter Agreement, to assess, among other things, (1) the system requirements and equipment requirements to interconnect the Facility with the Company System, (2) the Performance Standards of the Facility, and (3) an estimate of interconnection costs and project schedule for interconnection of the Facility.

“kV” means kilovolt.

“Land RFI” refers to a Request for Information activity conducted by the Company to identify interested parties willing to make land available for utility-scale renewable energy projects and gather relevant property information.

“Levelized Benefit” or “LB” means a calculation (\$/MWh) used for comparison of Proposals based on information provided in the Proposal submission in this RFP.

“LMI Anchor Tenant” is as defined in Tariff Rule No. 29 in Appendix J.

“LMI Subscriber” means either a LMI Customer or LMI Anchor Tenant as defined in Tariff Rule No. 29 in Appendix J.

“Low- and Moderate-Income Customer” or “LMI Customer” is as defined in Tariff Rule No. 29 in Appendix J.

“Lump Sum Payment” has the meaning set forth in the RDG PPA or Mid-Tier SFC. It may also be referred to as a monthly Lump Sum Payment to reflect the portion of the payment made each month.

“Mediation” means the confidential mediation conducted in Honolulu, Hawai‘i, pursuant to and in accordance with the Mediation Rules, Procedures, and Protocols of Dispute Prevention Resolution, Inc. (or its successor) or, in its absence, the American Arbitration Association then in effect.

“Mid-Tier Standard Form Contract” or “Mid-Tier SFC” means the pre-approved standard form contract that will be used for projects 250 kW or greater in size, up to and including 2.5 MW, in the form of Appendix L or N of this RFP.

“MW” means megawatt.

“MWh” means megawatt hour.

“NEP” means Net Energy Potential.

“Non-Price Evaluation Team” means Employees and consultants of the Company who evaluate the Proposal non-price related criteria as set forth in Section 4.4 of this RFP. Non-Price Evaluation Team members will not include any Shared Resources and will be solely made up of Company RFP Team Members.

“O&M” means operation and maintenance.

“Operating Period Security” has the meaning set forth in Section 14.4 of the RDG PPA and Mid-Tier SFC.

“Paired Projects” means a Project proposed that incorporates both an energy generation component and an energy storage component as part of its Facility.

“Performance Standards” means the various performance standards for the operation of the Facility to the Company as set forth in Section 3 of Appendix B, as such standards may be revised from time to time pursuant to Article 23 of the RDG PPA or the Mid-Tier SFC, and as described in Chapter 2 of this RFP.

“Point of Interconnection” has the meaning set forth in the RDG PPA and Mid-Tier SFC.

“Power Purchase Agreement” or “PPA” means an agreement between an electric utility company and the developer of a renewable energy generation facility to sell the power generated by the facility to the electric utility company.

“Price Evaluation Team” means Employees and consultants of the Company who evaluate the Proposal price related criteria as set forth in Section 4.4 of this RFP. Price Evaluation Team members will not include any Shared Resources and will be solely made up of Company RFP Team Members.

“Price for Purchase of Electric Energy” is the amount that the Company will pay the Seller for electric energy delivered to the Company in accordance with the terms and conditions of the RDG PPA on a monthly basis as described in Attachment J. This payment will be calculated in terms of dollars per MWh.

“Priority List” means the group of Proposals selected by Hawai'i Electric Light as described in Section 4.5 of this RFP.

“Project” means a Facility proposed to Hawai‘i Electric Light by a Proposer pursuant to this RFP.

“Proposal” means a proposal submitted to Hawai‘i Electric Light by a Proposer pursuant to this RFP.

“Proposal Due Date” means the date stated in RFP Schedule - Row 6 for IPP and Affiliate Proposals of this RFP.

“Proposal Fee” means the non-refundable fee for each proposal submitted as set forth in Section 1.8 of this RFP.

“Proposer” means a person or entity that submits a Proposal to Hawai‘i Electric Light pursuant to this RFP.

“Proposer’s Response Package” means the form in which the Proposal should be submitted, which is attached as Appendix B to this RFP.

“PUC” means the State of Hawai‘i Public Utilities Commission.

“RDG PPA” means the Model PV and/or Wind Renewable Dispatchable Generation Power Purchase Agreement that will be used for projects greater than 2.5 MW in size, attached as Appendix K and Appendix M respectively to this RFP.

“Renewable Portfolio Standards” or “RPS” means the Hawai‘i law that mandates that the Company and its subsidiaries generate or purchase certain amounts of their net electricity sales over time from qualified renewable resources. The RPS requirements in Hawai‘i are currently codified in HRS §§ 269-91 through 269-95.

“Request for Proposals” or “RFP” means a request for Proposals issued pursuant to a competitive bidding process authorized, reviewed, and approved by the PUC.

“RFP Schedule” means the schedule set forth in Table 1, Section 3.1 of this RFP.

“Self-Build Option” or “SBO” means a Proposal submitted by the Company that is responsive to the resource need identified in the RFP, as required by Section VI of the Framework.

“Self-Build Team” means agents of the Company who develop Self-Build Option proposals.

“Seller” means the entity that the Company is contracting with, as set forth in the RDG PPA and Mid-Tier SFC.

“Seller-Owned Interconnection Facilities” has the meaning set forth in the RDG PPA and Mid-Tier SFC.

“Site” means the parcel of real property on which the Facility, or any portion thereof, will be constructed and located, together with any Land Rights reasonably necessary for the construction, ownership, operation and maintenance of the Facility.

“Site Control” has the meaning set forth in Section 4.3 of this RFP.

“Threshold Requirements” has the meaning set forth in Section 4.3 of this RFP.

Any capitalized term not defined in this RFP has the meaning set forth in the RDG PPA and Mid-Tier SFC.

**DRAFT**  
**REQUEST FOR PROPOSALS**  
**FOR**  
**COMMUNITY-BASED RENEWABLE ENERGY TRANCHE 1**  
**ISLAND OF HAWAI'I**

DECEMBER 1, 2020

Docket No. 2015-0389

*Appendix B – Proposer's Response Package /  
Project Interconnection Data Request*

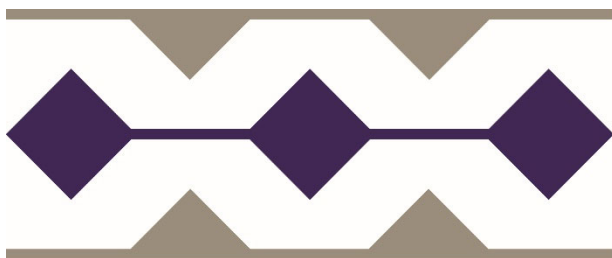

**Hawai'i  
Electric  
Light**

## 1.0 GENERAL INSTRUCTIONS TO PROPOSERS

The Company has elected to use the services of PowerAdvocate®, a third-party electronic platform provider. Sourcing Intelligence®, developed by PowerAdvocate®, is the Electronic Procurement Platform that the Company has licensed and will utilize for the RFP process. All Proposals and all relevant information must be submitted via the Electronic Procurement Platform, in the manner described in this RFP.

Proposers must adhere to the response structure and file naming conventions identified in this Appendix for the Proposer's response package. Information submitted in the wrong location/section or submitted through communication means not specifically identified by the Company will not be considered by the Company.

Proposers must provide a response for every item. If input/submission items in the RFP are not applicable to a specific Proposer or Proposal variation, Proposers must clearly mark such items as "N/A" (Not Applicable) and provide a brief explanation.

Proposers must clearly identify all confidential information in their Proposals, as described in more detail in Section 3.12 Confidentiality of the RFP.

All information (including attachments) must be provided in English. All financial information must be provided in U.S. Dollars and using U.S. credit ratings.

It is the Proposer's sole responsibility to notify the Company of any conflicting requirements, ambiguities, omission of information, or the need for clarification prior to submitting a Proposal.

The RFP will be conducted as a "Sealed Bid" event within Sourcing Intelligence, meaning the Company will not be able to see or access any of the Proposer's submitted information until after the event closes.

### 1.1 ELECTRONIC PROCUREMENT PLATFORM

To access the RFP event, the Proposer must register as a "Supplier"<sup>1</sup> on Sourcing Intelligence (Electronic Procurement Platform). One Proposal may be submitted with each Supplier registration. Minor variations, as defined in Section 1.8.2 and 1.8.3 of this RFP may be submitted along with the Proposal under the same registration.

If a Proposer is already registered on Sourcing Intelligence, the Proposer may use their current login information to submit their Proposal. Two variations of a Proposal, one variation of which is the base variation of the Proposal, may be submitted together as a Proposal by following the instructions outlined in this Appendix (see Section 4 below). If the Proposer chooses to submit more than one Proposal, the Proposer must register as a new "Supplier" on Sourcing Intelligence for each additional Proposal.

Each registration will require a unique username, unique Email address, and unique Company name. Proposers that require multiple registrations to submit multiple Proposals should use the Company name field to represent

---

<sup>1</sup> The language in Appendix B sometimes refers to "Energy Contract Managers" as "Bid Event Coordinator" and to "Proposers" as "Suppliers" (Bid Event Coordinator and Supplier are terms used by PowerAdvocate).



the Company name and Proposal number (ex: CompanyNameP1). Proposers may use shorthand or clear abbreviations. The unique Email address used to create the PowerAdvocate account does not necessarily have to match the Email address specified in Section 2.2.1 below. For example, if the Proposer is submitting multiple Proposals, all of the Proposer's Proposals could specify the same primary point of contact Email address if that is what the Proposer requests contact through for all their proposals.

Proposers can register for an account on Sourcing Intelligence by clicking on the "Registration" button (located in the top right corner of the webpage) on the PowerAdvocate website at the following address:

[www.poweradvocate.com](http://www.poweradvocate.com)

The Proposer's use of the Electronic Procurement Platform is governed by PowerAdvocate's Terms of Use. By registering as a "Supplier" on the Electronic Procurement Platform, the Proposer acknowledges that the Proposer has read these Terms of Use and accepts and agrees that, each time the Proposer uses the Electronic Procurement Platform, the Proposer will be bound by the Terms of Use then accessible through the link(s) on the PowerAdvocate login page.

Once a Proposer has successfully registered as a "Supplier" with PowerAdvocate, the Proposer shall request access to the subject RFP event from the Company Contact via Email through the RFP Email Address set forth in Section 1.6 of the RFP. The Email request must list the Company Name field and username under which the Proposer has registered with PowerAdvocate. If the Proposer plans to submit multiple Proposals and has registered multiple accounts in accordance with the instructions above, the Email request must contain the Company Name field and username for each account that will be used to submit the Proposals. After being added to the event, the Proposer will see the bid event on their dashboard upon logging into Sourcing Intelligence. Once the RFP event opens, the Proposer may begin submitting their Proposal(s).

After registering and prior to the opening of the RFP, Proposers are encouraged to familiarize themselves with the Electronic Procurement Platform, including tabs, the dashboard, PowerAdvocate Users Guide (RFP Appendix D), etc. Proposers should note that they will not be able to access any bid documents until the event officially opens.

Proposers may contact PowerAdvocate Support for help with registration or modification of registration if desired. Support is available from 8 AM to 8 PM Eastern Time (2 AM to 2 PM Hawai'i Standard Time when daylight savings is in effect) Monday to Friday, except for Holidays posted on the PowerAdvocate website, both by phone (857-453-5800) and by Email ([support@poweradvocate.com](mailto:support@poweradvocate.com)).

Contact information for PowerAdvocate Support can also be found on the bottom border of the PowerAdvocate website: [www.poweradvocate.com](http://www.poweradvocate.com)

Once the RFP event is opened, registered Proposers will have online access to general notices and RFP-related documents via the Electronic Procurement Platform. Proposers should also monitor the RFP Website throughout the RFP event.

## **1.2 PROPOSAL SUBMISSION PROCEDURES**

An Email notification will be sent to all registered Proposers when the event has been opened to receive Proposals.

After logging onto the Electronic Procurement Platform, the RFP will be visible on the Proposer's dashboard with several tabs, including the following:

- **"1. Download Documents:"** Documents stored under this tab are provided for the Proposer's use and information. All documents can be downloaded and/or printed, as required.
- **"2. Upload Documents:"** Proposal submission documents requested in Appendix B must be uploaded using this tab.
- Note that "3. Commercial Data:", "4. Technical Data:", and "5. Pricing Data:" tabs are NOT USED for this event.

Step-by-step instructions for submitting a complete Proposal are provided below:

1. Proposers must upload their Proposal files, including all required forms and files, to submit a complete Proposal. All files must be uploaded before the respective Proposal Due Date (RFP Section 3.1 Item 6 or Item 7).
2. Submit (upload) one consolidated PDF representing your Proposal via the "2. Upload Documents" tab. That Proposal PDF must abide by the format specified in this Appendix B. A MSWord.docx template that outlines the format of this document is available under the "1. Download Documents" tab for the Proposer's use. **Response information must be provided in the order, format, and manner specified in this Appendix B and must clearly identify and reference the Appendix B section number that the information relates to.**
  - a. Proposers shall use a filename denoting: CompanyName\_Proposal#.pdf.  
(example: AceEnergy\_P1.pdf)
3. Proposal information that cannot be easily consolidated into the PDF file described in Step 2 (such as large-scale drawing files) or files that must remain in native file format (such as computer models and spreadsheets) shall be **uploaded separately but must be referenced from within the main Proposal PDF file** (e.g., "See AceEnergyP1V2\_2.5\_SiteControlMap.kmz"). Such additional files must follow the naming convention below:
  - a. File names must include, in order, Company Name, Proposal number (if more than one Proposal being submitted per Proposer), Variation (if any variations are being submitted), Appendix B section number, and a file descriptor, as shown in the example file name below:  
AceEnergyP1V2\_2.5\_SiteControlMap.kmz  
Proposers may use abbreviations if they are clear and easy to follow.
4. Upload files using the **"2. Upload Documents"** tab on the Electronic Procurement Platform.
  - a. For all documents identify the "Document Type" as "Technical Information." (Do not identify any documents as "Commercial and Administrative" or "Pricing.")
  - b. "Reference ID" may be left blank.
  - c. Select "Choose File..." Navigate to and choose the corresponding file from your computer. Select "Open" and then "Submit Document."

There is no limit to the number or size of files that can be uploaded. Multiple files may be grouped into a .zip archive for upload. (Any zipped files must still adhere to the naming directions in #3 above.) When

successfully uploaded, documents will appear under the "Bid Submissions" section on the bottom of the tab's page, organized within the "Technical Information" Document Type. Repeat steps a, b, and c, as required for each file upload.

If a file with the same name is uploaded twice, the Platform will automatically append a unique numerical extension to the Document Name. To delete a file that has been previously uploaded, click on the "X" button in the "Actions" column for the file to be deleted. Do not upload any files prior to the issuance of the Final RFP.

5. The Company will not be responsible for technical problems that interfere with the upload or download of Proposal information. Support is available to answer technical questions about PowerAdvocate's Sourcing Intelligence from 8 AM to 8 PM Eastern Time (2 AM to 2 PM Hawai'i Standard Time when daylight savings is in effect) Monday to Friday, except for Holidays posted on the PowerAdvocate website, both by phone (857-453-5800) and by Email (support@poweradvocate.com).
6. Proposers are strongly encouraged to start early and avoid waiting until the last minute to submit the required information. Proposers are allowed to add, modify, and/or delete documents that have been previously submitted any time prior to the event close deadline. For clarity, it is the Proposer's responsibility to ensure a complete Proposal is uploaded into PowerAdvocate before the Proposal Due Date.
7. Any questions or concerns regarding the RFP, may be submitted to the Company Contact via the RFP Email address provided in Section 1.6 of the RFP. Per RFP Section 1.4.2, the Independent Observer will monitor messages within the bid event. Proposers are responsible for following instructions and uploading documents in their appropriate locations. Documents uploaded in the wrong tab will not be considered by the Company.

### 1.3 PROPOSAL COMPLETION AND CONFIRMATION PROCEDURES

To confirm the submission of all proposal files, in the "Status" tab on the Electronic Procurement Platform, confirm that the "Total Uploaded Files" is the number of expected files to be included in the submission by checking it against your list of submitted files. Example "Status" tab view:

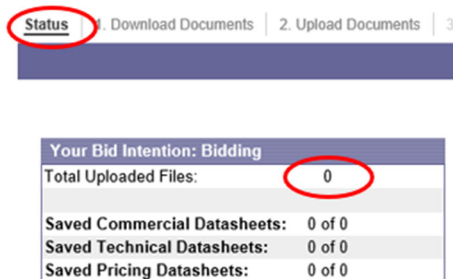

As stated above in Section 1.2, nothing should be uploaded to the Commercial, Technical or Pricing Datasheet tabs. Documents uploaded there will not be included in your Proposal submission.

1.3.1 **Proposal Fee Delivery Information.** Provide the Proposal Fee submission information for this Proposal. Include:

- The Date the Proposal Fee was sent.
- The delivery service used and the tracking number for the parcel.
- The U.S.-chartered bank name that issued the cashier’s check and the check number.

## 2.0 PROPOSAL (BASE VARIATION) SUMMARY TABLE

Base variation Proposal Summary. If proposal variations are submitted, any changes to the summary information for such variations must be specifically identified in a similar table placed in Sections 4.2, 4.3, 4.4, etc. of this Appendix, as applicable.

To be filled out in its entirety by IPP or Affiliate Proposers:

1	<b>Proposer Name (Company Name)</b>	
2	<b>Parent Company/Owner/Sponsor/Business Affiliation/etc.</b>	
3	<b>Project Name</b>	
4	<b>Net AC Capacity of the Facility (MW)</b>	
5	<b>Proposed Facility Location, Street Address if available, or what City/Area on the island is it near</b>	
6	<b>TMK(s) of Facility Location (use 9-digit TMK format)<sup>2</sup></b>	
7	<b>Point of Interconnection’s Circuit Name</b>	
8	<b>Coordinates for Point of Interconnection (use decimal degrees)<sup>3</sup></b>	
9	<b>Project Generation Technology</b>	
10	<b>Net Energy Potential (NEP) Projection for the Facility (MWh)</b>	
11	<b>Lump Sum Payment (\$/Year)</b>	
12	<b>Price for Purchase of Electric/Renewable Energy (\$/MWh) (optional and only for wind projects)</b>	
13	<b>Does Project include an Energy Storage Component? (Yes/No)</b>	
If the Project includes an Energy Storage Component:		
14	<b>Project Energy Storage Technology</b>	
15	<b>Energy Storage Capability for the Facility (MW and MWh)</b>	
16	<b>Is the Project capable of being 100% charged from the grid after the 5 year ITC recapture period? (Yes/No)</b>	
17	<b>Is the Project grid-forming and black start capable? (Yes/No)</b>	
18	<b>Proposal Guaranteed Commercial Operations Date (MM/DD/YYYY)</b>	
19	<b>The Proposer hereby certifies that the Project meets all performance attributes identified in Section 2.1 of the RFP? (Yes/No)</b>	

<sup>2</sup> 9-digit Tax Map Key format: Island Number (1 digit); Zone Number (1 digit); Section Number (1 digit); Plat Number (3 digits, add leading zeros if less than 3 digits); Parcel Number (3 digits, add leading zeros if less than 3 digits).

<sup>3</sup> Decimal degrees (YY.YYYYYY, -XXX.XXXXXX) latitude and longitude coordinates of the Point of Interconnection for the project. If there is more than one interconnection point, specify each.

20	<b>The Proposer hereby certifies that the Proposal (including its pricing elements) is not contingent upon changes to existing County, State or Federal laws or regulations. (Yes/No)</b>	
21	<b>The Proposer hereby agrees to provide Development Period Security and Operating Period Security as set forth in the applicable Model RDG PPA or Model Mid-Tier SFC. (Yes/No)</b>	
22	<b>The Proposer hereby certifies under penalties of perjury that this Proposal has been made in good faith and without collusion or fraud with any other person. As used in this certification, the word “person” shall mean any natural person, business partnership, corporation, union, committee, club, or organization, entity, or group of individuals. (Yes/No)</b>	
23	<b>The Proposer hereby certifies that the Proposer, its parent company, or any affiliate of the Proposer has not either defaulted on a current contract with the Company, had a contract terminated by the Company, or has any pending litigation with the Company (Yes/No)</b>	
24	<b>The Proposer hereby certifies that the Project is dedicated to LMI Subscribers with a minimum 60% dedicated to LMI Customers as described in Section 1.2.3 of the RFP? (Yes/No)</b>	

To be filled out in its entirety by Self-Build Proposers:

1	<b>Proposer Name (Company Name)</b>	
2	<b>Parent Company/Owner/Sponsor/Business Affiliation/etc.</b>	
3	<b>Project Name</b>	
4	<b>Net AC Capacity of the Facility (MW)</b>	
5	<b>Proposed Facility Location, Street Address if available, or what City/Area on the island is it near</b>	
6	<b>TMK(s) of Facility Location (use 9-digit TMK format)<sup>4</sup></b>	
7	<b>Point of Interconnection’s Circuit Name</b>	
8	<b>Coordinates for Point of Interconnection (use decimal degrees)<sup>5</sup></b>	
9	<b>Project Generation Technology</b>	
10	<b>Net Energy Potential (NEP) Projection for the Facility (MWh)</b>	
11	<b>Does Project include an Energy Storage Component? (Yes/No)</b>	
If the Project includes an Energy Storage Component:		
12	<b>Project Energy Storage Technology</b>	
13	<b>Energy Storage Capability for the Facility (MW and MWh)</b>	
14	<b>Is the Project capable of being 100% charged from the grid after the 5 year ITC recapture period? (Yes/No)</b>	
15	<b>Is the Project grid-forming and black start capable? (Yes/No)</b>	
16	<b>Proposal Guaranteed Commercial Operations Date (MM/DD/YYYY)</b>	
17	<b>The Proposer hereby certifies that the Project meets all performance attributes identified in Section 2.1 of the RFP? (Yes/No)</b>	
18	<b>The Proposer hereby certifies that the Proposal (including its pricing elements) is not contingent upon changes to existing County, State or Federal laws or regulations. (Yes/No)</b>	
19	<b>The Proposer hereby agrees to provide Development Period Security and Operating Period Security as set forth in the applicable Model RDG PPA or Model Mid-Tier SFC. (Yes/No)</b>	

<sup>4</sup> 9-digit Tax Map Key format: Island Number (1 digit); Zone Number (1 digit); Section Number (1 digit); Plat Number (3 digits, add leading zeros if less than 3 digits); Parcel Number (3 digits, add leading zeros if less than 3 digits).

<sup>5</sup> Decimal degrees (YY.YYYYYY, -XXX.XXXXXX) latitude and longitude coordinates of the Point of Interconnection for the project. If there is more than one interconnection point, specify each.

20	<b>The Proposer hereby certifies under penalties of perjury that this Proposal has been made in good faith and without collusion or fraud with any other person. As used in this certification, the word “person” shall mean any natural person, business partnership, corporation, union, committee, club, or organization, entity, or group of individuals.</b> (Yes/No)		
21	<b>The Proposer hereby certifies that the Project is dedicated to LMI Subscribers with a minimum 60% dedicated to LMI Customers as described in Section 1.2.3 of the RFP?</b> (Yes/No)		
22	<b>Year (YYYY)</b>	<b>Project Capital Cost (\$)</b>	
23	<b>Year (YYYY)</b>	<b>O&amp;M Cost (\$)</b>	
24	<b>Year (YYYY)</b>	<b>Annual Revenue Requirement (\$)</b>	

## 2.1 REQUIRED FORMS ACCOMPANYING PROPOSAL PDF

The following forms must accompany each proposal, must be attached to the Proposal PDF, and uploaded via the “2. Upload Documents” tab:

- Document signed by an officer or other Proposer representative **authorizing the submission** of the Proposal
- Fully executed **CBRE Mutual Confidentiality and Non-Disclosure Agreement** (Appendix E to the RFP, may be downloaded from the “1. Download Documents” tab in the Electronic Procurement Platform)
- **Certificate of Vendor Compliance** for the Proposer
  - **Certificate of Good Standing** for the Proposer and **Federal and State tax clearance certificates** for the Proposer may be provided in lieu of the Certificate of Vendor Compliance
- **Certification of Counsel for Proposer**, if applicable. (See Appendix B Attachment 1.)
- Completed applicable **Project Interconnection Data Request worksheet** for the proposed technology and **project diagram(s)**. **Models for equipment and controls, list(s)** identifying components and **respective files** (for inverters and power plant controller), and **complete documentation with**

**instructions** as specified in the Data Request worksheet shall be submitted within the respective timeframes specified in Section 5.1 of the RFP.<sup>6</sup> (See Section 2.11.1 below)

- [For Self-Build Only] **Self-Build Option Team Certification Form**. See Appendix G Attachment 1.
- [For Self-Build Only] **Revenue Requirements Worksheets** that support the annual revenue requirements estimates shall be submitted. A starter revenue requirements template file can be requested by the Self-Build Team via email to the RFP Email Address once the RFP event opens. The revenue requirements worksheets submitted will be modified to reflect the details of the Project's Proposal. All assumptions used will be reflected in an assumptions input tab.

## 2.2 PROPOSAL SUMMARY/CONTACT INFORMATION

2.2.1 Provide a **primary point of contact** for the Proposal being submitted:

- Name
- Title
- Mailing Address
- Phone Number
- Email Address – this will be the official communication address used during the RFP process

2.2.2 **Executive Summary of Proposal.** The executive summary must include an approach and description of the important elements of the Proposal, including a description if a minor variation to the base variation is being submitted. Refer to Section 1.8.2 and 1.8.3 of the RFP for an explanation of minor variations that are allowed. If a minor variation to the base variation is proposed, a **table summarizing the differences of the minor variation in Section 4 shall be included.**

2.2.3 **Pricing information.** Pricing information must be filled out in the Section 2.0 Proposal Summary Table above. If a minor variation to the base variation is proposed, the minor variation's pricing summary must be identified in a similar pricing table in Sections 4.2.0 below. Proposers must provide pricing information only in those table sections – do not embed pricing information in any other portion of the Proposal PDF.

2.2.4 Provide a **high-level overview of the proposed Facility**, including at a minimum the following information:

- Facility Generation Size (MW<sub>AC</sub> and MW<sub>DC</sub>)
- Net Maximum Output Capacity of the Facility at the Point(s) of Interconnection (MW<sub>AC</sub>)
- Identified Available Hosting Capacity of the Distribution-level (12 kV or less) Circuit Facility Interconnecting to (MW<sub>AC</sub>), if available. If a Hosting Capacity value is provided, please describe the source of the value (i.e. LVM, Company response to Proposer's inquiry, etc.).
- Technology Type
- Number of Generators
- Rated Output of each Generator

---

<sup>6</sup> If the Models, lists, respective files and complete documentation are not submitted with the Proposal upload, they shall be submitted via PowerAdvocate's Messaging as attachments within the respective timeframes specified in Section 5.1 of the RFP.

- Generator Facility Design Characteristics

For projects that include a storage component:

- Technology Type (i.e. lithium ion battery)
- Maximum Rated Output, as defined in the applicable contract (MW)
- Discharge Duration at Maximum Rated Output (hours)
- Storage Energy Capacity (MWh) available at the point of interconnection (i.e. BESS Contract Capacity as defined in the applicable contract)
- Operational Limitations, such as but not limited to: grid charging limits (with respect to ITC), energy throughput limits (daily, monthly, annually), State of Charge restrictions (min/max SOC while at rest (not charging/discharging)), etc. Proposed Operational Limits cannot be in conflict with the energy discharge requirement in Sections 1.2.12 and 1.2.13 of the RFP. If such a conflict is identified, the Proposal may be disqualified.
- Round Trip Efficiency (“RTE”). Specify a single value (percentage) that the Facility is required to maintain throughout the term of the applicable contract. The RTE must consider and reflect:
  - the technical requirements of the Facility (as further set forth in the applicable contract);
  - that the measurement location of charging and discharged energy is at the point of interconnection;
  - electrical losses associated with the point of interconnection measurement location;
  - any auxiliary and station loads that need to be served by BESS energy during charge and discharge that may not be done at Maximum Rated Output or over a fixed duration; and
  - that the data used to validate the RTE will be captured during a full charge cycle (0%-100% SOC) directly followed by a full discharge cycle (100%-0% SOC).
- Describe any augmentation plans for the storage component to maintain the functionality and characteristics of the storage during the term of the applicable contract. Include any expected interval of augmentation (months/years).
- Estimated useful life of the storage component (including augmentation if used) (years)

2.2.5 If the Project requires a RDG PPA as specified in RFP Section 3.8, **state whether the Proposer accepts the contract terms** identified in the model RDG PPA in its entirety or if modifications to the model agreements are proposed. Specify the name of the Microsoft Word red-line file that identifies the proposed modifications to the model language that the Proposer is agreeable to.

## 2.3 FINANCIAL

Provide the following financial information identified below. As specified in the General Instructions in Section 1.0 above, all information (including attachments) must be provided in English, be provided in U.S. Dollars and use U. S. credit ratings.

### 2.3.1 Identification of Equity Participants

2.3.1.1 Who are the **equity participants** in the Project (or the equity partners’ other partners)?

2.3.1.2 Provide an **organizational structure** for the Proposer including any general and limited partners and providers of capital that identifies:

- Associated responsibilities from a financial and legal perspective
- Percentage interest of each party



2.3.2 Project Financing

2.3.2.1 **How will the Project be financed** (including construction and term financing)? Address at a minimum:

- The Project's projected financial structure
- Expected source of debt and equity financing

2.3.2.2 [For IPP and Affiliate Proposals] Identify all **estimated development and capital costs** for, at a minimum:

- Equipment
  - Identify the manufacturer and model number for all major equipment
- Construction
- Engineering
- Seller-Owned Interconnection Facilities
- Land
- Annual O&M
- (For Projects that include a storage component) Specify a percentage of the total project cost that is estimated to be attributed to the storage functionality of the Facility. As the storage functionality is treated as a lease, the Company will use the percentage for its preliminary calculation of the lease liability only. This percentage requested for the Company's accounting purposes does not affect nor alter the liquidated damage provisions of the PPA, as those provisions reflect the benefit the Company seeks from the Project's storage functionality.

[For Self-Build Only] Identify all **estimated development and capital costs** for, at a minimum:

- Facility (including any generation and storage components)
- Outside Services
- Interconnection
- Overhead Costs
- Allowance for Funds Used During Construction
- Annual O&M
- Specify the percentage of the total cost associated with the storage component of the Facility
- (For Projects that include a storage component) Specify a percentage of the total project cost that is estimated to be attributed to the storage functionality of the Facility. As the storage functionality is treated as a lease, the Company will use the percentage for its preliminary calculation of the lease liability only. This percentage requested for the Company's accounting purposes does not affect nor alter the liquidated damage provisions of the PPA, as those provisions reflect the benefit the Company seeks from the Project's storage functionality.

2.3.2.3 Discuss and/or provide **supporting information on any project financing guarantees**.

2.3.2.4 Describe any **written commitments obtained from the equity participants**.

2.3.2.5 Describe any **conditions precedent to project financing**, and the Proposer's plan to address them, other than execution of the Power Purchase Agreement or any other applicable project agreements and

State of Hawai'i Public Utilities Commission approval of the Power Purchase Agreement and other agreements.

2.3.2.6 Provide any **additional evidence to demonstrate that the Project is financeable**.

2.3.3 Project Financing Experience of the Proposer

Describe **the project financing experience of the Proposer** in securing financing for projects of a similar size (i.e., no less than two-thirds the size) and technology as the one being proposed including the following information for any referenced projects:

- Project Name
- Project Technology
- Project Size
- Location
- Date of Construction and Permanent Financing
- Commercial Operations Date
- Proposer's Role in Financing of the Project
- Off-taker
- Term of the Interconnection Agreement
- Financing Structure
- Major Pricing Terms
- Name(s) of Finance Team Member(s); Time (i.e., years, months) worked on the project and Role/Responsibilities

2.3.4 Evidence of the Proposer's Financial Strength

2.3.4.1 Provide **copies of the Proposer's audited financial statements** (balance sheet, income statement, and statement of cash flows):

- Legal Entity
  - Three (3) most recent fiscal years
  - Quarterly report for the most recent quarter ended
- Parent Company
  - Three (3) most recent fiscal years
  - Quarterly report for the most recent quarter ended

2.3.4.2 Provide the **current credit ratings** for the Proposer (or Parent Company, if not available for Proposer), affiliates, partners, and credit support provider:

- Standard & Poor's
- Moody's
- Fitch

2.3.4.3 Describe any **current credit issues** regarding the Proposer or affiliate entities raised by rating agencies, banks, or accounting firms.

2.3.4.4 Provide any **additional evidence that the Proposer has the financial resources and financial strength** to complete and operate the Project as proposed.

2.3.5 Provide **evidence** that the Proposer can provide **the required securities**.

2.3.5.1 Describe the Proposer's **ability (and/or the ability of its credit support provider) and proposed plans to provide the required securities** including:

- Irrevocable standby letter of credit
- Sources of security
- Description of its credit support provider

2.3.6 Disclosure of Litigation and Disputes

Disclose any **litigation, disputes, and the status of any lawsuits or dispute resolution** related to projects owned or managed by the Proposer or any of its affiliates

## 2.4 CONTRACT EXCEPTIONS AND FINANCIAL COMPLIANCE

2.4.1 If Proposers elect to propose modifications to the Model RDG PPA, **provide a Microsoft Word red-line version of the Model RDG PPA** identifying specific proposed modifications to the model language that the Proposer is agreeable to and a detailed explanation and supporting rationale for each modification. General comments, drafting notes and footnotes such as “parties to discuss” are unacceptable and will be considered non-responsive.

Proposers that do not upload redlines of the applicable RDG PPA with their Proposal submission will be deemed to have accepted the Model RDG PPA in its entirety. If no modifications are proposed, please state in this section “no modifications to the Model RDG PPA”.

As set forth in RFP Section 3.8.5.1, proposed modifications to the RDG PPA will be subject to negotiation between the Company and the Final Award Group and should not be assumed to have been accepted either as a result of being selected to the Final Award Group or based on any previously executed PPA.

The Mid-Tier SFC for projects 250 kW or greater, up to and including 2.5 MW will be preapproved by the Commission and as a result, modifications may not be proposed to it.

2.4.2 State to the best of the Proposer's knowledge: Will the Project result in **consolidation** of the Developer entity's finances onto the Company's financial statements under FASB 810. **Provide supporting information** to allow the Company to verify such conclusion.

## 2.5 SITE CONTROL

2.5.1 The Proposal must demonstrate that the Proposer has Site Control for all real property required for the successful implementation of a specific Proposal at a Site not controlled by the Company, including any Interconnection Facilities for which the Proposer is responsible. In addition, developmental requirements and restrictions such as zoning of the Site and the status of easements must be identified. **Proposers must provide documentation set forth in RFP Section 4.3 to prove Site Control.**

2.5.2 Provide a **map of the Project site** that clearly identifies:

- Location of the parcel on which the site is located

- Tax map key number (9-digit format: Island Number (1 digit), Zone Number (1 digit), Section Number (1 digit), Plat Number (3 digits, add leading zeros if less than 3 digits), Parcel Number (3 digits, add leading zeros if less than 3 digits)
- Site boundaries (if the site does not cover the entire parcel)
- Total acreage of the site
- Point(s) of Interconnection
- Relationship of the site to other local infrastructure

2.5.3 Provide a **site layout plan** which illustrates:

- Proposed location of all equipment
- Proposed location of all facilities on the site, including any proposed line extensions

2.5.4 Describe the **interconnection route** and include:

- Site sketches of how the facility will be interconnected to the Company's System (above-ground and/or underground)
- Identify the approximate latitude and longitude of the proposed Point of Interconnection, in decimal degrees format, to six (6) decimal places.
- Description of the rationale for the interconnection route

2.5.5 Identify **any rights-of-way or easements** that are required for access to the site or for interconnection route:

- Describe the status of rights-of-way or easement acquisition
- Describe the plan for securing the necessary rights-of-way or easement, including the proposed timeline

2.5.6 Provide a **description of any critical infrastructure or community resilience hubs** in proximate location to the proposed Project site that could benefit from an islanding capability of the proposed Project and could enhance resilience in the community.

2.5.7 Indicate whether the Proposal is **intended to partially or fully satisfy a Company identified Non-Wire Alternative** as stated in Appendix O or the Company's Locational Value Map, and which locational need it intends to satisfy.

## 2.6 ENVIRONMENTAL COMPLIANCE AND PERMITTING PLAN

Scoring of proposals for the non-price evaluation criteria of this section will be based on the completeness and thoroughness of responses to each of the criteria listed below. The Company recommends that each Proposal incorporate the list below as an outline together with complete and thorough responses to each item in the list. Proposals that closely follow this recommendation will typically be awarded higher scores than proposals that do not.

2.6.1 Describe your **overall land use and environmental permits and approvals strategy** and approach to obtaining successful, positive results from the agencies and authorities having jurisdiction, including:

- Explanation of the conceptual plans for siting

- Studies/assessments
- Permits and approvals
- Gantt format schedule which identifies the sequencing of permit application and approval activities and critical path. (Schedule must be in MM/DD/YY format.)

2.6.2 Discuss the **city zoning and state land use classification**:

- Identify present and required zoning and the ability to site the proposed Project within those zoning allowances.
- Identify present and required land use classifications and the ability to site the proposed Project within those classifications.
- Provide evidence of proper zoning and land use classifications for selected site and interconnection route.
- If changes in the above are required for the proposed Project, provide a plan and timeline to secure the necessary approvals.

2.6.3 Identify all required discretionary and non-discretionary **land use, environmental and construction permits, and approvals** required for development, financing, construction, and operation of the proposed Project, including but not limited to zoning changes, Environmental Assessments, and/or Environmental Impacts Statements.

Provide a **listing of such permits and approvals** indicating:

- Permit Name
- Federal, State, or Local agencies and authorities having jurisdiction over the issuance
- Status of approval and anticipated timeline for seeking and receiving the required permit and/or license
- Explanation of your basis for the assumed timeline
- Explain any situation where a permit or license for one aspect of the Project may influence the timing or permit of another aspect (e.g. a case where one permit is contingent upon completion of another permit or license), if applicable.
- Explain your plans to secure all permits and approvals required for the Project.

2.6.4 Provide a **preliminary environmental assessment of the site** (including any pre-existing environmental conditions) and potential short- and long-term **impacts** associated with, or resulting from, the proposed Project – including direct, indirect, and cumulative impacts associated with development, construction, operation, and maintenance of the proposed Project in every area identified below. Discuss if alternatives have been or will be considered. The assessment shall also include Proposer’s short- and long-term plans to mitigate such impacts and explanation of the mitigation strategies for, but not limited to, each of the major environmental areas as presented below:

- Natural Environment
  - Air quality
  - Biology (Natural habitats and ecosystems, flora/fauna/vegetation, and animals, especially if threatened or endangered)
  - Climate
  - Soils
  - Topography and geology
- Land Regulation
  - Land Uses, including any land use restrictions and/or pre-existing environmental conditions/contamination
  - Flood and tsunami hazards

- Noise
- Roadways and Traffic
- Utilities
- Socio-Economic Characteristics
- Aesthetic/Visual Resources
- Solid Waste
- Hazardous Materials
- Water Quality
- Public Safety Services (Police, Fire, Emergency Medical Services)
- Recreation
- Potential Cumulative and Secondary Impacts

2.6.5 Provide a **decommissioning plan**, including:

- Developing and implementing program for recycling to the fullest extent possible, or otherwise properly disposing of installed infrastructure, if any, and
- Demonstrating how restoration of the Site to its original ecological condition is guaranteed in the event of default by the Proposer in the applicable Site Control documentation.

## 2.7 CULTURAL RESOURCE IMPACTS

2.7.1 Provide a **plan to address the below requirements** as they pertain to the Project Site and interconnection route including the status of any consultant/s with expertise in this field that have been identified and/or contracted with, and documentation of any assessments or work that has been planned or performed to date. Identify any cultural, historical or natural resources in the area in question. For any impacts identified to the categories listed below, provide a mitigation strategy and the expected impact on the Project schedule. Detail the potential impacts of the Proposal on cultural resources in the short- and long-term and the Proposer's plan to mitigate such impacts. Proposers must provide as much information as possible to allow the Company to understand the considerations.

- Archaeological Resources
- Cultural Practices and Resources

## 2.8 COMMUNITY OUTREACH

Gaining community support is an important part of a Project's viability and success. An effective Community Outreach Plan will call for early meaningful communications with stakeholders and will reflect a deep understanding and respect for the community's desire for information. The public meeting and comment solicitation process described in Section 5.3 of the RFP is intended to support that premise and the Commission's desire to increase bid transparency within the RFP process. When developers neglect to demonstrate transparency and a willingness to engage in early and frequent communication with Hawaii's communities, costly and timely challenges to their projects have resulted. In some instances, projects have failed. Incorporating transparency during the competitive bidding phase may seem unconventional, but it has become an essential community expectation. Developers must share information and work with communities to address concerns through careful listening, thoughtful responsiveness, and a commitment to respect the environmental and cultural values of Hawai'i.

2.8.1 Provide a **detailed Community Outreach Plan** to work with and inform neighboring communities and stakeholders and to provide them timely information during all phases of the Project. The plan shall address, but not be limited to, the following items:

- Project description
- Community scoping
- Project benefits
- Government approvals
- Development process
  - Identification of communities and other stakeholders that may be affected by the proposed Project:
    - How will they be affected?
    - What mitigation strategies will the Proposer implement?
- Comprehensive communication strategy with affected communities and the general public regarding the proposed Project:
  - Describe frequency of communication
  - Provide source of information
  - Identify communication outlets
  - Describe opportunities, if any for affected communities and general public to provide the developer with feedback and comments on the proposed Project

Proposers are reminded of RFP Section 3.4.2 including the provision of Proposals must provide all referenced material if it is to be considered during the Proposal evaluation.

2.8.2 Provide any **documentation of local community support or opposition** including any letters from local organizations, newspaper articles, or communications from local officials.

2.8.3 Provide a **description of community outreach efforts** already taken or currently underway, including the names of organizations and stakeholders contacted about the proposed Project.

2.8.4 Describe any anticipated or negotiated investment in the community and other **community benefits** that the Proposer proposes to provide in connection with the Project, along with an estimated value of the community benefits in dollars (including the cost to Proposers providing the benefits and supporting details on how those costs and benefits were derived).

2.8.5 All Proposers selected to the Final Award Group must display the below table of information on their website as described in Section 5.3 of the RFP to provide communities Project information that is of interest to them in a standard format. All information in this table must be included in all community presentations in addition to the Proposer’s project website.

### PROJECT SUMMARY AND COMMUNITY OUTREACH PLAN

*	Proposer Name (Company name)	
*	Parent Company/Owner/Sponsor/Business Affiliation/etc.	
*	Project Name	
*	Net AC Capacity of the Facility (MW) (must match Proposal information)	

*	Proposed Facility Location, Street Address if available, or what City/Area on the island it is near	
*	TMK(s) of Facility Location (must match Proposal information)	
*	Point of Interconnection's Circuit (must match Proposal information)	
*	Project Description (in 200 words or less)	<i>(A description that includes information about the project that will enable the community to understand the impact that the Project might have on the community.)</i>
*	Project site map	<i>(provide a map similar to what was provided in Section 2.5.2)</i>
*	Site layout plan	<i>(provide a layout similar to what was provided in Section 2.5.3)</i>
*	Interconnection route	<i>(provide a map of the route similar to what was provided in Section 2.5.4)</i>
<b>Environmental Compliance and Permitting Plan</b>		
*	Overall land use and environmental permits and approvals strategy	<i>(provide information in level of detail as provided in Section 2.6.1)</i>
*	Gantt format schedule which identifies the sequencing of permit applications and approval activities and critical path. Schedule must be in MM/DD/YY format)	<i>(provide information in level of detail as provided in Section 2.6.1)</i>
*	City Zoning and Land Use Classification	<i>(provide information in level of detail as provided in Section 2.6.2)</i>
*	Discretionary and non-discretionary Land use, environmental and construction permits and approvals	<i>(provide information in level of detail as provided in Section 2.6.3)</i>
*	Listing of Permits and approvals	<i>(provide information in level of detail as provided in Section 2.6.3)</i>
*	Preliminary environmental assessment of the Site (including any pre-existing environmental conditions)	<i>(provide information in level of detail as provided in Section 2.6.4)</i>
<b>Cultural Resource Impacts</b>		
*	Proposer's updated Community Outreach Plan must include a plan that (1) identifies any cultural, historic or natural resources that will be impacted by the Project (2) describes the potential impacts on these	<i>(provide information in level of detail as provided in Section 2.7)</i>



	resources and (3) identifies measures to mitigate such impacts.	
<b>Community Outreach</b>		
*	Detailed Community Outreach Plan	<i>(provide key information from Community Outreach Plan as specified in Section 2.8.1 or provide a link to updated comprehensive Community Outreach Plan)</i>
*	Local community support or opposition	<i>(provide latest comprehensive information)</i>
*	Community outreach efforts	<i>(provide latest comprehensive information)</i>
*	Community benefits	<i>(provide latest comprehensive information)</i>

## 2.9 OPERATIONS AND MAINTENANCE (O&M)

2.9.1 To demonstrate the long-term operational viability of the proposed Project, describe the **planned operations and maintenance**, including:

- Operations and maintenance funding levels, annually, throughout the term of the contract.
- Description of the operational requirements by frequency (daily, weekly, monthly, yearly, as-necessary, run hour interval) and maintenance requirements by frequency (daily, weekly, monthly, yearly, as-necessary, run hour interval).
- A discussion of the staffing levels proposed for the Project and location of such staff. If such staff is offsite, describe response time and ability to control the Project remotely.
- Technology specific maintenance experience records.
- Identification of any O&M providers.
- The expected role of the Proposer (Owner) or outside contractor.
- Scheduling of major maintenance activity.
- Plan for testing equipment.
- Estimated life of Generation and/or Storage Facilities and associated Interconnection Facilities.
- Safety plan, including historical safety records with environmental history records, violations, and compliance plans.
- Security plan.
- Site maintenance plan.
- Substation equipment maintenance plan.

2.9.2 State whether the Proposer would **consider 24-hour staffing**. Explain how this would be done.

2.9.3 Describe the **Proposer's contingency plan**, including the Proposer's mitigation plans to address failures. Such information should be described in the Proposal to demonstrate the Project's reliability with regard to potential operational issues.

2.9.4 Describe if the Proposer will **coordinate their maintenance schedule** for the Project with the Company's annual planned generation maintenance. See Article 5 of the model RDG PPA.

2.9.5 Describe the **status of any O&M agreements or contracts** that the Proposer is required to secure. Include a discussion of the Proposer's plan for securing a long-term O&M contract.

2.9.6 Provide **examples of the Proposer's experience with O&M services** for other similar projects.

## 2.10 PERFORMANCE STANDARDS

2.10.1 Design and operating information. Provide a **description of the project design**. Description shall include:

- Configuration description, including conceptual or schematic diagrams Overview of the Facility Control Systems – central control and inverter- or resource-level control
- Diagrams approved by a Professional Electrical Engineer registered in the State of Hawai'i, indicated by the presence of the Engineer's Professional seal on all drawings and documents. Including but not limited to:
  - A single-line diagram, relay list, trip scheme and settings of the generating facility, which identifies the Point of Interconnection, circuit breakers, relays, switches, synchronizing equipment, monitoring equipment, and control and protective devices and schemes.
  - A three-line diagram which shows the Point of Interconnection, potential transformer (PT) and current transformer (CT) ratios, and details of the generating facility configuration, including relays, meters and test switches.

2.10.1.1 Provide the projected **hourly annual energy potential production profile of the Facility<sup>7</sup> (24 hours x 365 days, 8760 generation profile)** for the provided NEP RFP Projection.

2.10.1.2 Provide the **sample rate of critical telemetry** (i.e. frequency and voltage) based on inputs to the facility control systems.

2.10.1.3 Provide a description of the Facility's **capability to be grid-forming and have black start capability**.

2.10.1.4 Provide the explanation of the methodology and underlying **information used to derive the Project's NEP RFP Projection**, including the preliminary design of the Facility and the typical meteorological year file used to estimate the Renewable Resource Baseline, as required in Article 6.6 of the applicable Model PV Large RDG PPA and Mid-Tier SFC. The explanation of the methodology should include, but not be limited to, the long-term resource data used, the gross and net generation MWh, and assumptions (loss factors, uncertainty values, any grid or project constraints).

2.10.2 Capability of **Meeting Performance Standards**. The proposed Facility must meet the performance attributes identified in Section 2.1 of the RFP. Provide **confirmation that the proposed Facility will meet the requirements identified** or provide clarification or comments about the Facility's ability to meet the performance standards. Proposals should include sufficient documentation to support the stated claim that the Facility will be able to meet the Performance Standards. The Proposal should include

---

<sup>7</sup> For Paired Projects, the projected hourly annual energy production profile is the projected output from the generating facility without curtailment and before any energy is directed to an energy storage component.

information required to make such a determination in an organized manner to ensure this evaluation can be completed within the evaluation review period.

2.10.3 **Reactive Power Control:** Provide the facility's **ability to meet the Reactive Power Control capabilities**, including Voltage Regulation at the point of interconnection, required in the Performance Standards, including contribution from the inverters of generation and/or storage and means of coordinating the response. Provide the inverter capability curve(s). Confirm ability to provide reactive power at zero active power.

2.10.4 **Ramp Rate** for Generation Facilities: Confirm the ability to meet the ramp rate requirement specified in the Model RDG PPA or Mid-Tier SFC.

2.10.5 **Undervoltage ride-through:** Provide the facility's terminal voltage level(s) and elapsed time at which the facility will disconnect from the utility system during the disturbance, if any. Confirm the ability to meet ride-through requirements and include supporting documentation regarding inverter design, control parameters, etc.

2.10.6 **Overvoltage ride-through:** Provide the facility's terminal voltage level(s) and elapsed time at which the facility will disconnect from the utility system during the disturbance, if any. Confirm the ability to meet ride-through requirements and include supporting documentation regarding inverter design, control parameters, etc.

2.10.7 **Transient stability ride-through:** Provide the facility's ability to stay online during Company System: (1) three-phase fault located anywhere on the Company System and lasting up to \_\_ cycles; and (2) a single line to ground fault located anywhere on the Company System and lasting up to \_\_ cycles. Provide the Facility's ability to withstand subsequent events.

2.10.8 **Underfrequency ride-through:** Provide the facility's terminal frequency level(s) and elapsed time at which the facility will disconnect from the utility system during the disturbance, if any. Confirm the ability to meet ride-through requirements and include supporting documentation regarding inverter design, control parameters, etc.

2.10.9 **Overfrequency ride-through:** Provide the facility's terminal frequency level(s) and elapsed time at which the facility will disconnect from the utility system during the disturbance, if any. Confirm the ability to meet ride-through requirements and include supporting documentation regarding inverter design, control parameters, etc.

2.10.10 **Frequency Response:** Provide the facility's frequency response characteristics as required by the Model RDG PPA or Mid-Tier SFC, including time of response, tunable parameters, alternate frequency response modes and means of implementing such features.

2.10.11 **Auxiliary Power Information:** Proposer must provide the maximum auxiliary power requirements for:

- Start-up
- Normal Operations (from generator)
- Normal Operating Shutdown
- Forced Emergency Shutdown

- Maintenance Outage

2.10.12 **Coordination of Operations:** Provide a description of the control facilities required to coordinate generator operation with and between the Company's System Operator and the Company's System.

- Include a description of the equipment and technology used to facilitate dispatch to the Company and communicate with the Company.
- Include a description of the control and protection requirements of the generator and the Company's System.

2.10.13 **Cycling Capability:** Describe the Facility's ability to cycle on/off and provide limitations.

2.10.14 **Active Power Control Interface:** Describe the means of implementing active power control and the Power Possible, including the contribution to the dispatch signal from paired storage, if any. Provide the Proposer's experience dealing with active power control, dispatch, frequency response, and ride-through.

2.10.15 Provide the details of the **major equipment** (i.e. batteries, inverters, battery management system), including, but not limited to, name of manufacturer, models, key metrics, characteristics of the equipment, and performance specifications.

2.10.16 **Energy Storage performance standards:** For projects that include a storage component, provide additional performance standard descriptions as follows:

- MWh storage output for a full year
- Ramp Rate: Provide the Facility's ramp rate, which should be no more than 2 MW/minute for all conditions other than those under control of the Company System Operator and/or those due to desired frequency response.
- System Response Time – Idle to Design Maximum (minutes)
- Discharge Start-up time (minutes from notification)
- Charge Start-up time (minutes from notification)
- Start and run-time limitations, if any
- Ancillary Services provided, if any (i.e. Spinning Reserves, Non-Spinning Reserves, Regulation Up, Regulation Down, Black Start capability, other )

2.10.17 Provide the description and details of the **grid-charging capabilities of the Facility**. Include a description on the ability to control the charging source.

## 2.11 INTERCONNECTION SUBMITTAL REQUIREMENTS

2.11.1 For projects greater than or equal to 1 MW in size, provide the appropriate completed **Project Interconnection Requirement Study Data Request worksheets** for the proposed technology with the Proposal submission. The worksheets can be found in the "1. Download Documents" tab as Appx B Att 2a or 2b with the respective file names of Project Interconnection Data Request Worksheets (PV Generation) and Project Interconnection Data Request Worksheet (Wind Generation) MSEXcel files. Also provide all **project diagram(s)** with the Proposal submission. **Models for equipment and controls, list(s)** identifying components and **respective files** (for inverters and power plant controller), and **complete documentation with instructions** shall be submitted within the timeframes specified in Section 5.1 of the RFP.<sup>6</sup> Proposers

may also download the Facility Technical Model Requirements and Review Process documentation labelled as Appx B Att 3 from the “1. Download Documents” tab also.

## 2.12 PROVEN TECHNOLOGY

2.12.1 Provide all supporting information for the Company to assess the **commercial and financial maturity of the technology** being proposed. Provide any supporting documentation that shows examples of projects that:

- Use the technology at the scale being proposed
- Have successfully reached commercial operations (for example, by submitting a PPA)
- Demonstrate experience in providing Active Power dispatch

## 2.13 EXPERIENCE AND QUALIFICATIONS

Proposers, its affiliated companies, partners, and/or contractors and consultants are required to demonstrate project experience and management capability to successfully develop and operate the proposed Project.

2.13.1 Provide an **organizational chart** for the Project that lists the project participants and identifies the management structure and responsibilities. In addition to the organizational chart, Proposers must provide a completed table:

- For each of the project participants (including the Proposer, partners, and proposed contractors), **fill out the table below** and provide statements that list the specific experience of the firm in: financing, designing, constructing, interconnecting, owning, operating, and maintaining renewable energy generating or storage facilities, or other projects of similar size and technology, and
- Provide any evidence that the project participants have worked jointly on other projects.

<b>EXPERIENCE:</b>							
In the applicable columns below, include project details (i.e., project name, location, technology, size) and relevant job duties (role/responsibilities) and time (in years/months) spent on the project. List multiple projects if applicable.							
Participant Name:	Financing	Designing	Constructing	Interconnecting	Owning	Operating	Maintaining
1.							
2.							
3.							
...							

2.13.2 Identify those **member(s) of the team** the Proposer is submitting to meet the experience Threshold Requirement and demonstrate the member(s) firm commitment to provide services to the Proposer.

2.13.3 Identify those **members of the team with experience and qualifications**, including affiliates, and their principal personnel who will be involved in the project contracting to sell and deliver energy. If the Proposer consists of multiple parties, such as joint ventures or partnerships, provide this information for each

party, clearly indicating the proposed role of each party, including an ownership chart indicating direct and indirect ownership, and percentage interests in the partnership or joint venture.

2.13.4 Provide a **management chart** which lists the key personnel dedicated to this Project and provide **biographies / resumes** of the key personnel, including position, years of relevant experience, and similar project experience. Provide specifics as they relate to financing of renewable energy projects. Identify architects and engineers or provision to provide same that are licensed to practice in the State of Hawai‘i.

2.13.5 Provide a **listing in the table format below, of all renewable energy generation or energy storage projects** the Proposer has successfully developed or that are currently under construction. Describe the Proposer’s role and responsibilities associated with these projects (lead developer, owner, investor, etc.). Provide the following information as part of the response:

Project Name	Location (City, State)	Technology (wind, PV, hydro, plus storage, etc.)	Size (MW/ MWh)	Commercial Operation Date	Offtaker (if applicable)	Role & Responsibilities
1.						
2.						
3.						
...						

## 2.14 STATE OF PROJECT DEVELOPMENT AND SCHEDULE

2.14.1 Provide a **project schedule in GANTT chart format** with complete **critical path activities** identified for the Proposal from the Notice of Selection of the Proposal to the start of Commercial Operations.

- The **schedule** must include:
  - Interconnection Requirement Study (IRS) assumptions
  - Anticipated contract negotiation period assumptions
  - Regulatory assumptions
  - Anticipated submittal and approval dates for permitting (including but not limited to environmental and archaeological compliance)
  - Siting and land acquisition
  - Cultural Resource implications and mitigation activities
  - Community outreach and engagement activities
  - Energy resource assessment
  - Financing
  - Engineering
  - Procurement
  - Facility construction including construction management events
  - Applicable reporting milestone events specified in the Model RDG PPA or Mid-Tier SFC
  - Testing
  - Interconnection (including engineering, procurement, and construction)
  - Commercial Operations Date
  - All other important elements outside of the direct construction of the Project

- For each project element, list the start and end date (must be in MM/DD/YY format), and include predecessors to clearly illustrate schedule dependencies and durations.
- Proposers must also list and describe critical path activities and milestone events, particularly as they relate to the integration and coordination of the project components and the Company's Electric System. Proposers must ensure that the schedule provided in this section is consistent with the milestone events contained in the RDG PPA or Mid-Tier SFC and/or other agreements.

2.14.2 Describe the **construction execution strategy** including:

- Identification of contracting/subcontracting plans
- Modular construction
- Safety plans<sup>8</sup>
- Quality control and assurance plan
- Labor availability
- Likely manufacturing sites and procurement plans
- Similar projects where these construction methods have been used by the Proposer.

2.14.3 Provide a description of any **project activities that have been performed to date**.

2.14.4 Explain how you plan to reach **safe harbor milestones** (if applicable) and **guaranteed commercial operations**, including durations and dependencies which support this achievement.

### 3.0 PROPOSED CBRE PROGRAM

Provide a detailed description of the CBRE program that will be offered to eligible subscribers, including at a minimum, but not limited to, a discussion of the following. Please refer to the CBRE program non-price criteria in the RFP for elements of the proposed CBRE program that Proposals will be evaluated on.

- Financing Options
  - LMI Subscriber fees and payments
    - Upfront payments
    - Ongoing payments
  - Public funding options
  - Extent to which subscribers will be financially responsible for any facility underperformance
- Percentage of the project's capacity that will be available to subscribers vs. unsubscribed capacity
  - Capacity allocation (%) and other commitments to residential subscribers
  - Capacity allocation (%) and other commitments to low to moderate income ("LMI") subscribers
- Marketing or outreach plans to advertise the proposed project/program to LMI eligible customers
- Strategies for LMI customer retention and maintaining LMI customer participation levels
- Customer protection provisions
- Estimated benefits to LMI customer participants
  - Expected savings
  - Payback periods
  - Payback mechanisms

---

<sup>8</sup> A document that describes the various safety procedures and practices that will be implemented on the Project and how applicable safety regulations, standards, and work practices will be enforced on the Project.

- Other benefits
- Prior experience, specifically relating to community-based renewable energy projects
- Plans for CBRE program administration
  - Strategies for subscriber retention
  - How turnover and churn of subscribers will be handled

## 4.0 MINOR PROPOSAL VARIATION

Proposers submitting a minor variation to their base variation (as allowed in RFP Section 1.8.2 and 1.8.3) **must** provide the **details of the variation in the below section**. In this proposal variation Section 4.0 below, Proposers **must** (1) complete a Proposal Summary identical to Section 2.0 of this Appendix B. The information in this table must reflect the information for the variation being proposed. As specified in Section 2.2.2 above, Proposers submitting a variation must also (2) include a table summarizing the differences between the base variation and the minor variation. Additionally, Proposers must (3) identify all changes to any information provided in response to Sections 2.1 through 3.0 of this Appendix B for the proposal variation. If differences from any section in Sections 2.1 through 3.0 are not identified, the Company will assume that the information contained in the base Proposal (Sections 2.1 through 3.0) also applies to this proposal variation.

### 4.1 RESERVED

#### 4.2.0 PROPOSAL VARIATION SUMMARY TABLE

Replicate the entire Summary Table here. The responses to all line items must reflect the variation being proposed.

#### 4.2.1 through 4.3.0 RESPECTIVE SECTIONS AS NECESSARY

Identify differences to any Appendix B Section 2.1 through 3.0 here.

Note: Section 2.2.2 above requires a table summarizing the differences between the variations, if variations are proposed. For convenience, please duplicate the table summarizing the differences here.



**Certification of Counsel for Proposer  
Hawaiian Electric Company, Inc., Maui Electric Company, Ltd, and Hawai'i Electric Light  
Company, Inc.**

Pursuant to Section 1.7.4 of Hawaiian Electric Company, Inc., Hawai'i Electric Light Company, Inc. and Maui Electric Company, Limited's (each a "Company" and collectively, the "Companies") Request For Proposals for Community-Based Renewable Energy Projects for Low- and Moderate-Income Subscribers, Island of Maui ("RFP"), the Companies may require legal counsel who represent multiple unaffiliated proposers to sign a certification that they have not shared confidential information obtained through the representation of one proposer with any other unaffiliated proposer.

Accordingly, by signing below, I hereby acknowledge, agree and certify that:

(1) in connection with the RFP, I represent the following company that has submitted a proposal(s) for the RFP: \_\_\_\_\_ ("Proposer");

(2) irrespective of any proposer's direction, waiver or request to the contrary, I will not share a proposer's confidential information or the Company's confidential information associated with such proposer, including, but not limited to, a proposer's or Company's negotiating positions, with third parties unaffiliated with Proposer (by contract or organizational structure), including other proposers responding to the RFP;

(3) the Companies may rely on this certification for purposes of the RFP; and

(4) at the conclusion of power purchase agreement negotiations, if any, the Company may require me to sign a certificate certifying that I have not shared a proposer's confidential information or the Company's confidential information associated with such proposer, including, but not limited to, a proposer's or Company's negotiating positions, with third parties unaffiliated with Proposer (by contract or organizational structure), including other proposers responding to the RFP.

\_\_\_\_\_  
Name (print)

\_\_\_\_\_  
Law Firm (if applicable)

\_\_\_\_\_  
Signature

\_\_\_\_\_  
Date

Section 1.7.4 of the RFP provides in relevant part that:

In submitting a Proposal in response to this RFP, each Proposer certifies that the Proposal has been submitted in good faith and without fraud or collusion with any other unaffiliated person or entity. The Proposer shall acknowledge this in the Response Package submitted with its Proposal. Furthermore, in executing the NDA provided as Appendix E, the Proposer agrees on behalf of its Representatives (as defined in the NDA) that the Company's negotiating positions will not be shared with other Proposers or their respective Representatives.

In addition, in submitting a Proposal, a Proposer will be required to provide Company with its legal counsel's written certification in the form attached as Appendix B Attachment 1 certifying in relevant part that irrespective of any proposer's direction, waiver, or request to the contrary, that the attorney will not share a proposer's confidential information associated with such Proposer with others, including, but not limited to, such information such as a Proposer's or Company's negotiating positions. If legal counsel represents multiple unaffiliated proposers whose Proposals are selected for the Final Award Group, such counsel will also be required to submit a

similar certification at the conclusion of power purchase agreement negotiations that he or she has not shared a proposer's confidential information or the Company's confidential information associated with such Proposer with others, including but not limited to, such information as a Proposer's or Company's negotiating positions.

Updated 7/13/2020

**Project Interconnection - Data Request**

**FOR PV GENERATION**

**PROJECT:** \_\_\_\_\_

**DATE:** \_\_\_\_\_

(Nonexclusive Preliminary List)

\*\*\*ALL ITEMS ARE REQUIRED AND ALL RESPONSES MUST BE FILLED UNLESS NOT APPLICABLE.\*\*\*

	Response
1) Please provide a plan map of the Renewable Generation facility. Please indicate the interconnection point to the HECO system.	
2) Please provide the following generation and load information for the Renewable Generation facility:	
a. Gross and net output of the facility	
b. Expected KW and KVAR loads including, but not limited to, generators' auxiliary load curve, process load(s) profile(s), etc.	
c. Expected minimum and maximum MW and MVAR "import from" AND "export to" HECO.	
3) Please provide Single-Line Diagram(s), Three-Line Diagram(s), and Protective Relay List & Trip Schedule for the generation and interconnection facilities:	
a. The Single-line diagram(s) and Three-line diagram (s) should include:	
i. For main and generator step up transformer(s), please show:	
• Transformer voltage and MVA ratings.	
• Transformer impedance(s).	
• Transformer winding connections and grounding. If neutrals are grounded through impedance, please show the impedance value.	
ii. The protective relaying and metering for the generators, transformers, buses, and all other main substation equipment.	
iii. For the potential transformers, please indicate the type, quantity, ratio, and accuracy rating.	
iv. For the current transformers, please indicate the type, quantity, ratio, and accuracy rating, and thermal rating factor.	
v. Auxiliary power devices (e.g. capacitors, reactors, storage systems, etc.) and their rating(s); additional inquiries may be made to obtain technical data for these devices.	
vi. For the interconnection / tie lines (overhead or underground) and the plant's generation system, please provide the following, as applicable:	
• Installation details such as cross-section(s), plan and profiles, etc.	
• Conductor data such as size, insulation, length etc.	
• Continuous and emergency current ratings.	
• Voltage rating (nominal and maximum KV).	
• BIL rating.	
• Positive, negative, and zero-sequence impedances (resistance, reactance, and susceptance)	
• Capacitance or charging current.	
• Short-circuit current capability.	
vii. Include station power for facility and all applicable details.	
viii. All applicable notes pertaining to the design and operation of the facility.	
b. The Protective relay list & trip schedule should list the protected equipment; the relay description, type, style number, quantity, ANSI Device No., and range; and the breaker(s)/switching device(s) tripped, for both the generator protection and the interconnection facilities protection.	
c. Please provide both a paper and an electronic version (e.g. dgn, dxf, or pdf) of the single-line diagram(s) and the protective relay list & trip schedule.	
d. Single-line diagrams should be provided for both the generation plant and the interconnection substation.	

Updated 7/13/2020

**Project Interconnection - Data Request**

**FOR PV GENERATION**

PROJECT: \_\_\_\_\_

DATE: \_\_\_\_\_

(Nonexclusive Preliminary List)

\*\*\*ALL ITEMS ARE REQUIRED AND ALL RESPONSES MUST BE FILLED UNLESS NOT APPLICABLE.\*\*\*

		Response
4)	<b>For the PV Inverter Based Generating Facility, please provide the following data:</b>	
	a. Inverter manufacturer, Type, Size, Impedances. Attach copy of inverter data sheet.	
	b. Power Factor Range Capability	
	c. Inverter Reactive Power Capability Curve	
	d. Auxillary loads (P, Q, Power Factor)	
	e. Inverter's Internal Isolation Transformer Grounding Method, if used (i.e. effectively grounded, resonant grounded, low inductance grounded, high-resistance grounded, low-resistance grounded, ungrounded). If the transformer is not solidly grounded, provide the impedance value for the grounding neutral and the impedance for the isolation transformer.	
	f. Diagram for Inverter's internal isolation transformer	
	g. Switching and service restoration practice	
	h. Protection data (voltage ride-through and trip settings, frequency ride-through and trip settings etc.). Include setpoint and clearing time ranges for voltage and frequency settings.	
	i. Description of harmonic spectrum of inverter injection (order, magnitude)	
5)	<b>Energy Storage System, if applicable</b>	
	a. Operation characteristics	
	b. Voltage level	
	c. Capacity (how long and how much can the battery support)	
	d. Deployment strategy/schedule	
	e. Energy storage system data sheet	
6)	<b>For the PV plant's collector system, please provide the following, as applicable:</b>	
	a. Conductor data such as size, insulation, etc.	
	b. Continuous and emergency current ratings.	
	c. Voltage rating (nominal and maximum kV).	
	d. BIL rating.	
	e. Positive, negative, and zero-sequence impedances (resistance, reactance, and susceptance).	
	f. Capacitance or charging current.	
	g. Short-circuit current capability.	

Updated 7/13/2020

**Project Interconnection - Data Request  
FOR PV GENERATION**

PROJECT: \_\_\_\_\_

DATE: \_\_\_\_\_

(Nonexclusive Preliminary List)

\*\*\*ALL ITEMS ARE REQUIRED AND ALL RESPONSES MUST BE FILLED UNLESS NOT APPLICABLE.\*\*\*

	Response
7) <b>Please provide the following software models that accurately represent the Facility:</b> (For model requirements, refer to the HECO Facility Technical Model Requirements and Review Process and PSCAD Model Requirements Rev.9)	
a. Validated PSS/E load flow model up to the point of interconnection. The PSS/E model shall include the main transformer, collection system, generator step-up transformers, inverter systems, and any other components including capacitor banks, energy storage systems, DVAR, etc. An equivalent representation of the collection system, generator step-up transformers, and inverter systems is acceptable. Documentation on the model shall be provided.	
b. Validated PSS/E dynamic model for the inverter; and other components including energy storage system, DVAR, etc. if applicable. The inverter model shall include the generator/converter, electrical controls, plant-level controller, and protection relays. Generic and Detailed models shall be provided. Documentation on the model(s) shall be provided, including the PSS/E dyre file with model parameters.	
i. Generic models shall parameterize models available within the PSS/E standard model library.	
ii. Detailed models shall be supplied by the vendor/manufacturer as user-written models. The uncompiled source code for the user-written model shall be provided to ensure compatability with future versions of PSS/E. In lieu of the uncompiled source code, a compiled object file and applicable library files shall be provided in PSS/E versions 33 AND 34 format. Updates of the object file compatible with future PSS/E versions must be provided as requested for the life of the project as written in the power purchase agreement. Documentation shall include the characteristics of the model, including block diagrams, values, names for all model parameters, and a list of all state variables.	
c. Validated PSCAD model of the inverter; and other components including energy storage system, DVAR, auxiliary plant controllers, etc. if applicable. Documentation on the model(s) shall be provided. Refer to PSCAD Model Requirements Memo for model requirements.	
d. Overlaid plots validating the performance of the three dynamic models for a three-phase fault. Plots shall include voltage, real and reactive power, real and reactive current.	
e. Validated Aspen Oneliner short circuit model that accurately represents the facility (including energy storage system if applicable), and is valid for all faults conditions anywhere on the Utility system. Documentation on the model(s) shall be provided. (OTHERWISE SEE ADDITIONAL TABS FOR REQUIRED INFORMATION TO MODEL INVERTER AS A GENERATOR OR A VOLTAGE CONTROLLED CURRENT SOURCE)	
8) <b>For the main transformer and generator step-up transformers, please provide:</b>	
a. Transformer voltage and MVA ratings, and available taps. Attach copy of transformer test report or data sheet	
b. The tap settings used.	
c. The LTC Control Scheme.	
d. Transformer winding connections and grounding used. If the transformer is not solidly grounded, provide the impedance value for the grounding method.	
e. Positive, negative, and zero sequence impedance values.	
9) <b>For the circuit breakers and fault-clearing switching devices, including the generator breakers, please provide:</b>	
a. The voltage, continuous current and interrupting capability ratings.	
b. The trip speed (time to open).	

Updated 7/13/2020

**Project Interconnection - Data Request  
FOR PV GENERATION**

PROJECT: \_\_\_\_\_

DATE: \_\_\_\_\_

(Nonexclusive Preliminary List)

\*\*\*ALL ITEMS ARE REQUIRED AND ALL RESPONSES MUST BE FILLED UNLESS NOT APPLICABLE.\*\*\*

		Response
10)	<b>For the power fuses, please provide:</b>	
	a. The manufacturer, type, size, and interrupting capability.	
	b. The minimum melt and total clearing curves.	
11)	<b>For the protective relaying, please provide:</b>	
	a. Data for the CTs used with the relaying including the manufacturer, type of CT, accuracy class, and thermal rating factor.	
	b. Data for the PTs used with the relaying including the manufacturer, type of PT, voltage ratings, and quantity.	

Instructions:

Please fill in the data in the green blanks below

(Note: This does not include the internal isolation transformer, if used)

[1] Maximum rated output power =  kVA

[2] Impedances in **Per Unit** based on kVA from [1]

	R	X
Subtransient =	<input type="text"/>	<input type="text"/>
Transient =	<input type="text"/>	<input type="text"/>
Synchronous =	<input type="text"/>	<input type="text"/>
Negative Sequence =	<input type="text"/>	<input type="text"/>
Zero Sequence =	<input type="text"/>	<input type="text"/>

[3] Neutral impedance (if any) in actual **Ohms**:

R	X
<input type="text"/>	<input type="text"/>

NOTE: These parameters should reflect the inverter response for all types of faults at any point on the electrical system to which the inverter is connected. This includes faults at the inverter output terminals, and also on the 138 kV transmission system. If the stated parameters do not cover this range, please state the adjustments needed to these parameters to accurately represent the inverter response across this range.

These parameters will be used to model the inverter in the Aspen Oneliner program as shown in the sample dialog box below:

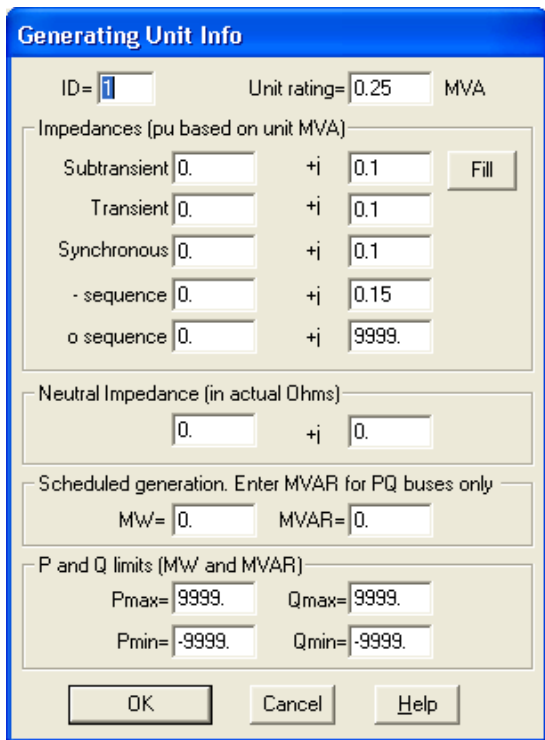

Instructions:

Please fill in the data in the green blanks below

- [1] Internal open circuit voltage  
 Magnitude =  Per Unit  
 Angle =  Degrees
- [2] AC Output Current Limit =  Amps

NOTE: These parameters should reflect the inverter response for all types of faults at any point on the electrical system to which the inverter is connected. This includes faults at the inverter output terminals, and also on the 138 kV transmission system. If the stated parameters do not cover this range, please state the adjustments needed to these parameters to accurately represent the inverter response across this range.

These parameters will be used to model the inverter in the Aspen Oneliner program as shown in the sample dialog box below:

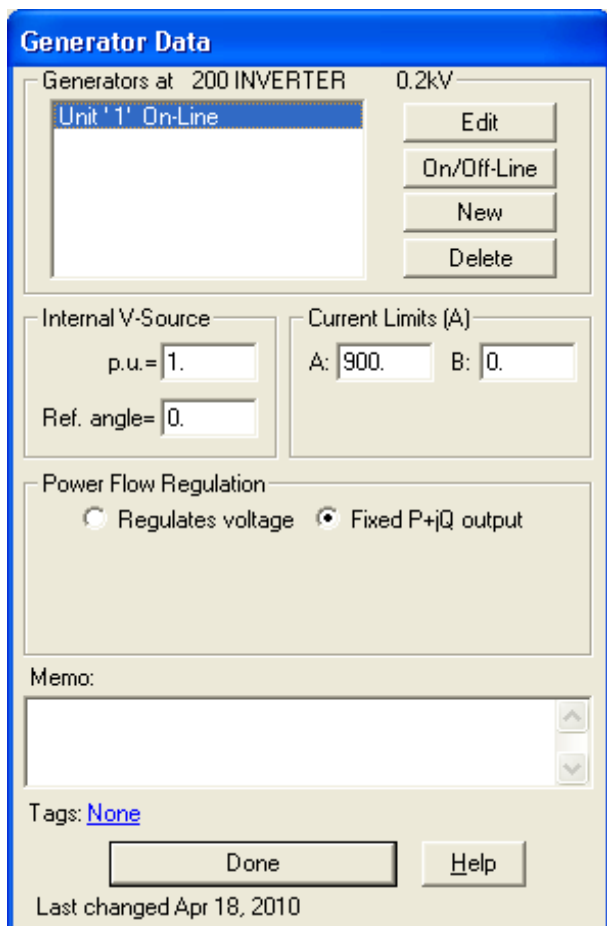



Instructions:

Please fill in the data in the green blanks below

[1] Inverter MVA Rating:  MVA

[2] Voltage-Current Characteristics:

Voltage PU	Current (A)	PF Angle (deg)
<input type="text"/>	<input type="text"/>	<input type="text"/>
<input type="text"/>	<input type="text"/>	<input type="text"/>
<input type="text"/>	<input type="text"/>	<input type="text"/>
<input type="text"/>	<input type="text"/>	<input type="text"/>

[3] Location of Voltage Measurement:

Device Terminal OR  
 Network side of Transformer

[4] Maximum Voltage:  Times prefault value

[5] Minimum Voltage  Per Unit

These parameters will be used to model the inverter in the Aspen Oneliner program as shown in the sample dialog box below:

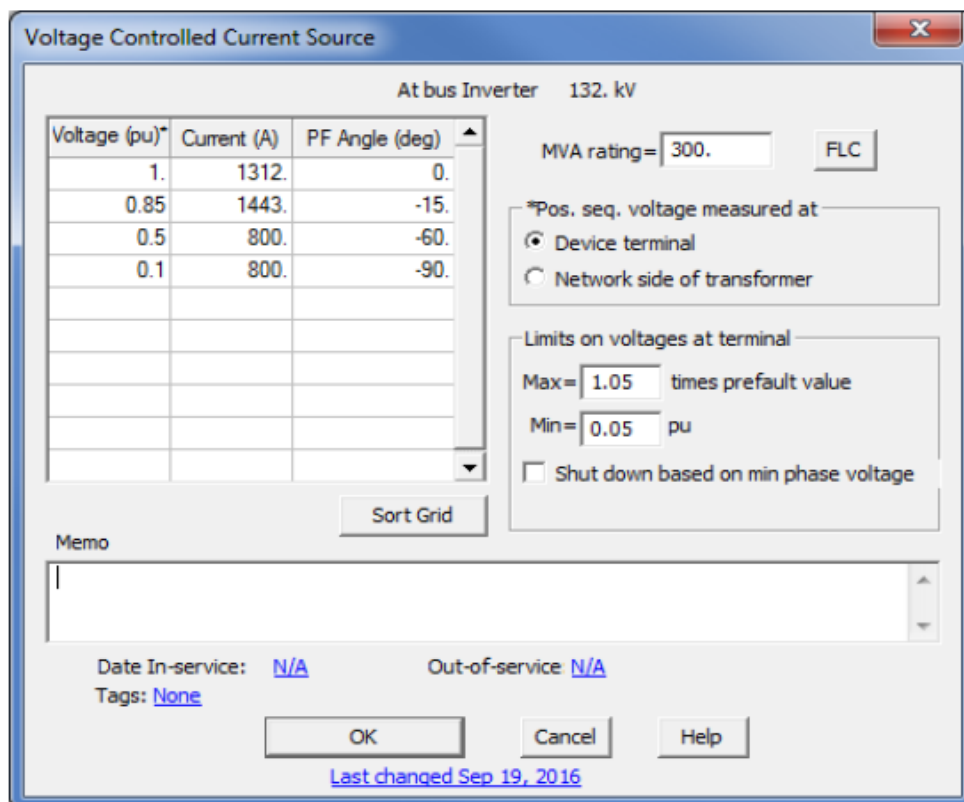

Instructions:

Please fill in the data in the green blanks below

(Note: This is not required if an internal isolation transformer is not used)

[1] Transformer rated power =  kVA

[2] Winding Configuration  
 Inverter Side =  Delta/Wye  
 Customer Side =  Delta/Wye

[2] Impedances in **Per Unit** based on kVA  
 Positive Sequence = 

	R	X
Zero Sequence =	<input style="width: 100%; height: 15px;" type="text"/>	<input style="width: 100%; height: 15px;" type="text"/>

[3] Neutral impedance (if any) in actual **Ohms**:  

	R	X
	<input style="width: 100%; height: 15px;" type="text"/>	<input style="width: 100%; height: 15px;" type="text"/>

These parameters will be used to model the inverter in the Aspen Oneliner program as shown in the sample dialog box below:

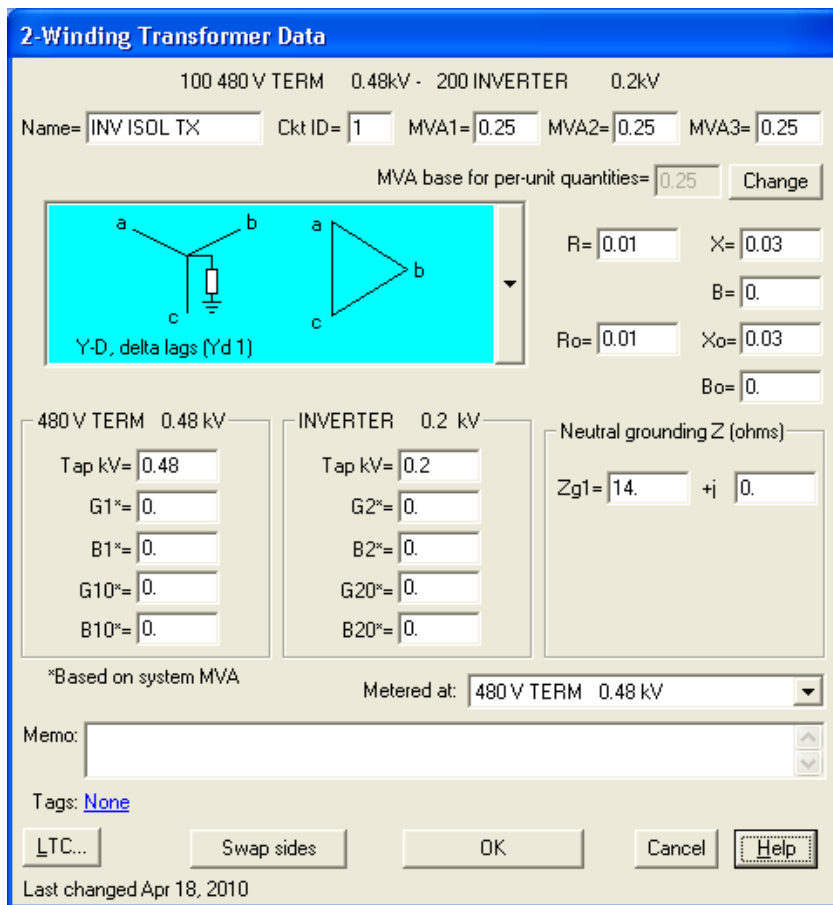

Updated 8/28/2020

**Project Interconnection - Data Request**

**FOR WIND GENERATION**

**PROJECT:** \_\_\_\_\_

**DATE:** \_\_\_\_\_

(Nonexclusive Preliminary List)

\*\*\*ALL ITEMS ARE REQUIRED AND ALL RESPONSES MUST BE FILLED UNLESS NOT APPLICABLE.\*\*\*

	Response
1) Please provide a plan map of the Non-Utility Generation (NUG) facility. Please indicate the interconnection point to the HECO system.	
2) Please provide the following generation and load information for the NUG facility:	
a. Gross and net output of the facility	
b. Expected KW and KVAR loads including, but not limited to, generators' auxiliary load curve, process load(s) profile(s), etc.	
c. Expected minimum and maximum MW and MVAR "import from" AND "export to" HECO.	
3) Please provide Single-Line Diagram(s), Three-Line Diagram(s), and Protective Relay List & Trip Schedule for the generation and interconnection facilities:	
a. The Single-line diagram(s) and Three-line diagram (s) should include:	
i. For main and generator step up transformer(s), please show:	
• Transformer voltage and MVA ratings.	
• Transformer impedance(s).	
• Transformer winding connections and grounding. If neutrals are grounded through impedance, please show the impedance value.	
ii. The protective relaying and metering for the generators, transformers, buses, and all other main substation equipment.	
iii. For the potential transformers, please indicate the type, quantity, ratio, and accuracy rating.	
iv. For the current transformers, please indicate the type, quantity, ratio, and accuracy rating, and thermal rating factor.	
v. Auxiliary power devices (e.g. capacitors, reactors, storage systems, etc.) and their rating(s); additional inquiries may be made to obtain technical data for these devices.	
vi. For the interconnection / tie lines (overhead or underground) and the plant's generation system, please provide the following, as applicable:	
• Installation details such as cross-section(s), plan and profiles, etc.	
• Conductor data such as size, insulation, length etc.	
• Continuous and emergency current ratings.	
• Voltage rating (nominal and maximum KV).	
• BIL rating.	
• Positive, negative, and zero-sequence impedances (resistance, reactance, and susceptance)	
• Capacitance or charging current.	
• Short-circuit current capability.	
vii. Include station power for facility and all applicable details.	
viii. All applicable notes pertaining to the design and operation of the facility.	
b. The Protective relay list & trip schedule should list the protected equipment; the relay description, type, style number, quantity, ANSI Device No., and range; and the breaker(s)/switching device(s) tripped, for both the generator protection and the interconnection facilities protection.	
c. Please provide both a paper and an electronic version (e.g. dgn, dxf, or pdf) of the single-line diagram(s) and the protective relay list & trip schedule.	
d. Single-line diagrams should be provided for both the generation plant and the interconnection substation.	

Updated 8/28/2020

**Project Interconnection - Data Request**

**FOR WIND GENERATION**

**PROJECT:** \_\_\_\_\_

**DATE:** \_\_\_\_\_

(Nonexclusive Preliminary List)

\*\*\*ALL ITEMS ARE REQUIRED AND ALL RESPONSES MUST BE FILLED UNLESS NOT APPLICABLE.\*\*\*

	Response
4) <b>For the Wind Generating Facility, please provide the following data:</b>	
a. Turbine manufacturer, Type, Size, Impedances. Attach copy of turbine data sheet.	
b. Power Factor Range Capability	
c. Turbine Reactive Power Capability Curve	
d. Auxillary loads (P, Q, Power Factor)	
e. Grounding Method (i.e. effectively grounded, resonant grounded, low inductance grounded, high-resistance grounded, low-resistance grounded, ungrounded). If the transformer is not solidly grounded or ungrounded, provide the impedance value for the grounding neutral, if applicable.	
f. Provide grounding diagram.	
g. Switching and service restoration practice	
h. Protection data (voltage ride-through and trip settings, frequency ride-through and trip settings etc.). Include setpoint and clearing time ranges for voltage and frequency settings.	
k. Description of harmonic spectrum of inverter injection (order, magnitude)	
5) <b>Energy Storage System, if applicable</b>	
a. Operation characteristics	
b. Voltage level	
c. Capacity (how long and how much can the battery support)	
d. Deployment strategy/schedule	
e. Energy storage system data sheet	
6) <b>For the Wind plant's collector system, please provide the following, as applicable:</b>	
a. Conductor data such as size, insulation, etc.	
b. Continuous and emergency current ratings.	
c. Voltage rating (nominal and maximum kV).	
d. BIL rating.	
e. Positive, negative, and zero-sequence impedances (resistance, reactance, and susceptance).	
f. Capacitance or charging current.	
g. Short-circuit current capability.	

Updated 8/28/2020

**Project Interconnection - Data Request**

**FOR WIND GENERATION**

**PROJECT:** \_\_\_\_\_

**DATE:** \_\_\_\_\_

**(Nonexclusive Preliminary List)**

**\*\*\*ALL ITEMS ARE REQUIRED AND ALL RESPONSES MUST BE FILLED UNLESS NOT APPLICABLE.\*\*\***

	Response
7) <b>Please provide the following software models that accurately represent the Facility:</b> (For model requirements, refer to the HECO Facility Technical Model Requirements and Review Process and PSCAD Model Requirements Rev.9)	
a. Validated PSS/E load flow model up to the point of interconnection. The PSS/E model shall include the main transformer, collection system, generator step-up transformers, wind turbines, and any other components including capacitor banks, energy storage systems, DVAR, etc. An equivalent representation of the collection system, generator step-up transformers, and turbines is acceptable. Documentation on the model shall be provided.	
b. Validated PSS/E dynamic model for the wind turbine; and other components including energy storage system, DVAR, etc. if applicable. The wind turbine model shall include the generator/converter, electrical controls, plant-level controller, protection relays, and mechanical systems that impact its electrical performance. Generic and Detailed models shall be provided. Documentation on the model(s) shall be provided, including the PSS/E dyre file with model parameters.	
i. Generic models shall parameterize models available within the PSS/E standard model library.	
ii. Detailed models shall be supplied by the vendor/manufacturer as user-written models. The uncompiled source code for the user-written model shall be provided to ensure compatibility with future versions of PSS/E. In lieu of the uncompiled source code, a compiled object file and applicable library files shall be provided in PSS/E versions 33 AND 34 format. Updates of the object file compatible with future PSS/E versions must be provided as requested for the life of the project as written in the power purchase agreement. Documentation shall include the characteristics of the model, including block diagrams, values, names for all model parameters, and a list of all state variables.	
c. Validated PSCAD model of the wind turbine; and other components including energy storage system, DVAR, etc. if applicable. Documentation on the model(s) shall be provided. Refer to PSCAD Technical Memo for model requirements.	
d. Overlaid plots validating the performance of the three dynamic models for a three-phase fault. Plots shall include voltage, real and reactive power, real and reactive current.	
e. Validated Aspen Oneliner short circuit model that accurately represents the facility (including energy storage system if applicable), and is valid for all faults conditions anywhere on the Utility system. Documentation on the model(s) shall be provided. (OTHERWISE SEE ADDITIONAL TABS FOR REQUIRED INFORMATION TO MODEL INVERTER)	
8) <b>For the main transformer and generator step-up transformers, please provide:</b>	
a. Transformer voltage and MVA ratings, and available taps. Attach copy of transformer test report or data sheet	
b. The tap settings used.	
c. The LTC Control Scheme.	
d. Transformer winding connections and grounding used. If the transformer is not solidly grounded, provide the impedance value for the grounding method.	
e. Positive, negative, and zero sequence impedance values.	
9) <b>For the circuit breakers and fault-clearing switching devices, including the generator breakers, please provide:</b>	
a. The voltage, continuous current and interrupting capability ratings.	
b. The trip speed (time to open).	

**Project Interconnection - Data Request**

Updated 8/28/2020

FOR WIND GENERATION

PROJECT: \_\_\_\_\_

DATE: \_\_\_\_\_

(Nonexclusive Preliminary List)

\*\*\*ALL ITEMS ARE REQUIRED AND ALL RESPONSES MUST BE FILLED UNLESS NOT APPLICABLE.\*\*\*

	Response
10) For the power fuses, please provide:	
a. The manufacturer, type, size, and interrupting capability.	
b. The minimum melt and total clearing curves.	
11) For the protective relaying, please provide:	
a. Data for the CTs used with the relaying including the manufacturer, type of CT, accuracy class, and thermal rating factor.	
b. Data for the PTs used with the relaying including the manufacturer, type of PT, voltage ratings, and quantity.	

Instructions:

Please fill in the data in the green blanks below

(Note: This does not include the internal isolation transformer, if used)

[1] Maximum rated output power =  kVA

[2] Impedances in **Per Unit** based on kVA from [1]

	R	X
Subtransient =	<input type="text"/>	<input type="text"/>
Transient =	<input type="text"/>	<input type="text"/>
Synchronous =	<input type="text"/>	<input type="text"/>
Negative Sequence =	<input type="text"/>	<input type="text"/>
Zero Sequence =	<input type="text"/>	<input type="text"/>

[3] Neutral impedance (if any) in actual **Ohms**:

R	X
<input type="text"/>	<input type="text"/>

NOTE: These parameters should reflect the inverter response for all types of faults at any point on the electrical system to which the inverter is connected. This includes faults at the inverter output terminals, and also on the 138 kV transmission system. If the stated parameters do not cover this range, please state the adjustments needed to these parameters to accurately represent the inverter response across this range.

These parameters will be used to model the inverter in the Aspen Oneliner program as shown in the sample dialog box below:

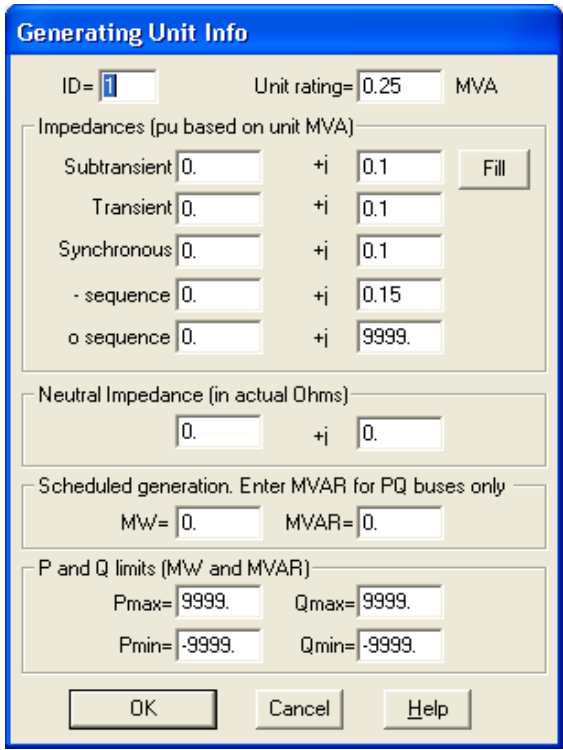

Instructions:

Please fill in the data in the green blanks below

- [1] Internal open circuit voltage  
 Magnitude =  Per Unit  
 Angle =  Degrees
- [2] AC Output Current Limit =  Amps

NOTE: These parameters should reflect the inverter response for all types of faults at any point on the electrical system to which the inverter is connected. This includes faults at the inverter output terminals, and also on the 138 kV transmission system. If the stated parameters do not cover this range, please state the adjustments needed to these parameters to accurately represent the inverter response across this range.

These parameters will be used to model the inverter in the Aspen Onliner program as shown in the sample dialog box below:

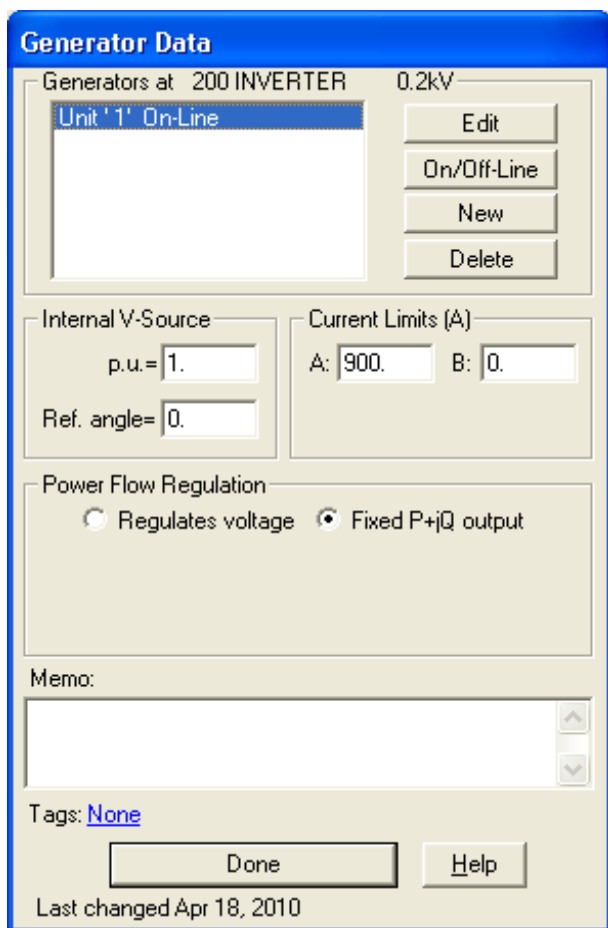



Instructions:

Please fill in the data in the green blanks below

[1] Inverter MVA Rating:  MVA

[2] Voltage-Current Characteristics:

Voltage PU	Current (A)	PF Angle (deg)
<input type="text"/>	<input type="text"/>	<input type="text"/>
<input type="text"/>	<input type="text"/>	<input type="text"/>
<input type="text"/>	<input type="text"/>	<input type="text"/>
<input type="text"/>	<input type="text"/>	<input type="text"/>

[3] Location of Voltage Measurement:

Device Terminal OR  
 Network side of Transformer

[4] Maximum Voltage:  Times prefault value

[5] Minimum Voltage  Per Unit

These parameters will be used to model the inverter in the Aspen Oneliner program as shown in the sample dialog box below:

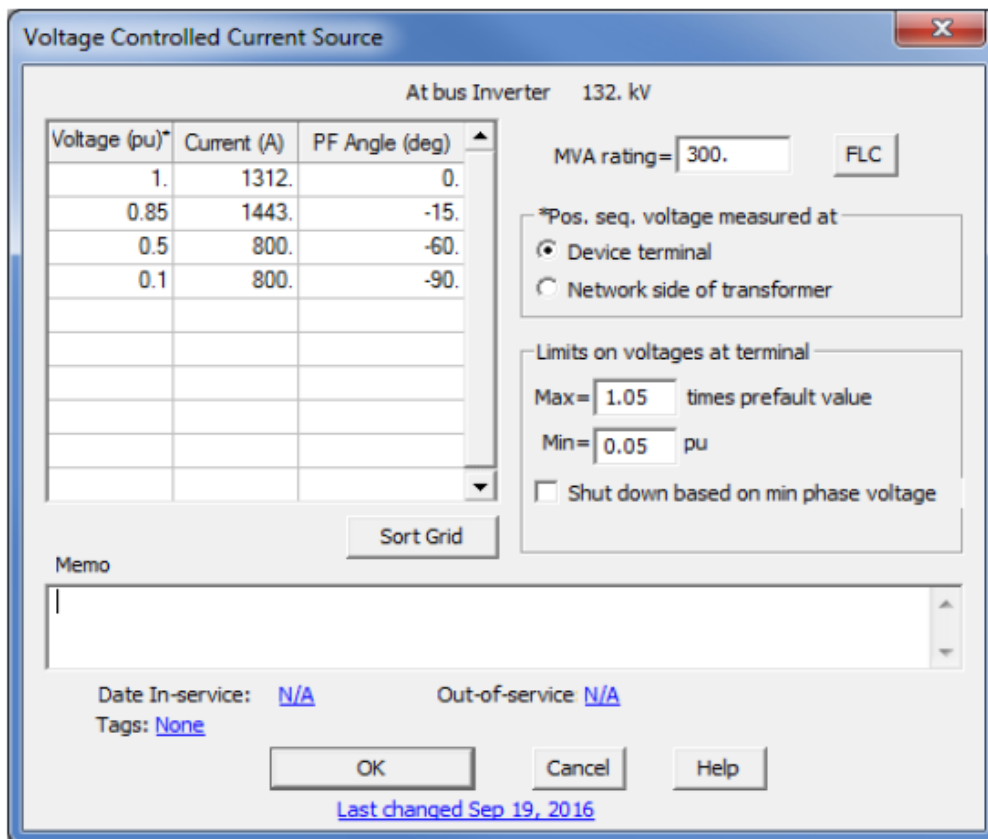

Instructions:

Please fill in the data in the green blanks below

(Note: This is not required if an internal isolation transformer is not used)

[1] Transformer rated power =  kVA

[2] Winding Configuration  
 Inverter Side =  Delta/Wye  
 Customer Side =  Delta/Wye

[2] Impedances in **Per Unit** based on kVA

	R	X
Positive Sequence =	<input type="text"/>	<input type="text"/>
Zero Sequence =	<input type="text"/>	<input type="text"/>

[3] Neutral impedance (if any) in actual **Ohms**:

R	X
<input type="text"/>	<input type="text"/>

These parameters will be used to model the inverter in the Aspen Oneliner program as shown in the sample dialog box below:

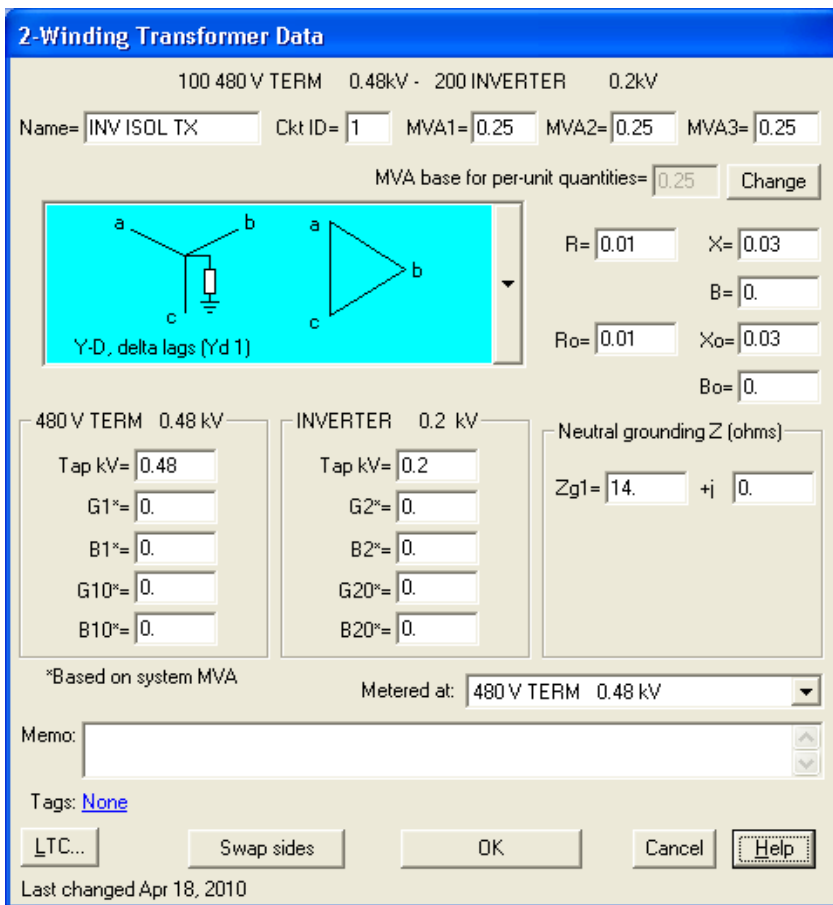

Appendix B Attachment 3

# HECO FACILITY TECHNICAL MODEL REQUIREMENTS AND REVIEW PROCESS

---

March 17, 2020

## Table of Contents

FACILITY TECHNICAL MODEL REQUIREMENTS AND REVIEW PROCESS.....	0
1 INTRODUCTION .....	1
2 FACILITY TECHNICAL MODEL REQUIREMENTS.....	2
2.1 General requirements for all technical models .....	2
2.2 Requirements for generation facility PSCAD model .....	3
2.3 Requirements for generation facility generic PSS/E power flow model .....	3
2.4 Requirements for generation facility user defined PSS/E dynamic model .....	3
2.5 Requirements for generation facility user defined PSS/E dynamic model .....	4
2.6 Requirements for generation facility ASPEN model .....	5
3 GENERATION FACILITY TECHNICAL MODEL REVIEW PROCESS .....	6
3.1 Model review in PSCAD .....	6
3.2 Model review in PSS/E.....	6
4 TYPICAL ISSUES IDENTIFIED FROM THE FACILITY MODEL DURING THE PAST RFP PROCESS ...	8
REFERENCE .....	9
APPENDIX A: SAMPLE OVERLAID GENERATION FACILITY TECHNICAL MODEL OUTPUT PLOT FOR THREE-PHASE FAULT .....	10
APPENDIX B: SAMPLE TEST SYSTEM EQUIVALMENT IMPEDANCE INFORMATION .....	12

# **1** INTRODUCTION

---

This document summarizes requirements of generation facility technical model submittals for request for proposals for variable renewable dispatchable generation and energy storage and describes the review process for model submittals.

## 2 FACILITY TECHNICAL MODEL REQUIREMENTS

---

To fully investigate impacts of the proposed generation facility on Hawaiian Electric's system and correctly identify any mitigation measures, the proposed generation facility technical model, along with related technical documents, will need to be submitted as part of the project interconnection review and prior to the Interconnection Requirements Study (IRS). The generation facility technical model includes:

1. PSCAD model
2. Generic PSS/E power flow model
3. User defined PSS/E dynamic model
4. Generic PSS/E dynamic model, and
5. ASPEN model

Along with the technical models, following documents should also be submitted for review:

6. User manual for all technical models
7. Generation facility one-line diagram
8. Generation unit manufacturer datasheet
9. Generation unit reactive power capability curve
10. Overlaid generation facility technical model output data for three-phase fault and single-phase fault. (Sample plots are shown in Appendix A)

### 2.1 General requirements for all technical models

All technical models need to represent the whole generation facility, not only a generation unit such as one inverter. At minimum, the following equipment shall be included in the generation facility model:

1. Generation unit, such as inverter with DC side model, rotation machine with model of exciter and governor.
2. Step up transformer
3. Collection system
4. Main interconnection transformer, or GSU, with its tap changer if applicable
5. Grounding transformer
6. Conductor
7. Var compensation device, such as cap bank or STATCOM, if applicable
8. Power plant controller (not for ASPEN model)
9. Documentation
10. Gen-tie line (as applicable)

An equivalent representation of the collection system, generator step-up transformers, and inverter systems is acceptable.

## 2.2 Requirements for generation facility PSCAD model

In addition to the general requirements mentioned above, the generation facility PSCAD model shall satisfy requirements as described in the document "PSCAD Model Requirements Rev. 9" provided by Hawaiian Electric.

## 2.3 Requirements for generation facility generic PSS/E power flow model

The generation facility PSS/E power flow model shall be provided for both PSS/E version 33 and version 34. Besides the general requirements mentioned above, the following modeling data shall be provided in the model:

1. Conductor
  - a. Impedance, both positive sequence and zero sequence
  - b. Rating: Rating A – normal rating, and Rating B – emergency rating
2. Transformer
  - a. Nominal voltages of windings
  - b. Impedance data: specified R and X
  - c. Tap ratios
  - d. Min and Max tap position limits
  - e. Number of tap positions
  - f. Regulated bus
  - g. Ratings: Rate A – normal rating; Rate B – emergency rating
  - h. Winding configuration
3. Reactive power compensation, if applicable
  - a. Fixed Shunts: G-Shunt (MW), B-Shunt (MVar)
  - b. Switched Shunts: Voltage limits (V<sub>hi</sub> and V<sub>low</sub>), mode of operation (fixed, discrete, continuous), regulated bus, Binit (MVar), steps and step size (MVar)
4. Generation unit
  - a. P<sub>max</sub>
  - b. P<sub>min</sub>
  - c. Q<sub>max</sub>
  - d. Q<sub>min</sub>
  - e. Name plate MVA
  - f. Transformer data: R<sub>Tran</sub>, X<sub>Tran</sub>, and G<sub>entap</sub>.
  - g. Voltage control point

## 2.4 Requirements for generation facility user defined PSS/E dynamic model

The submitted user defined PSS/E dynamic model should meet the following requirements:

1. The generation facility PSS/E dynamic model shall be provided for both PSS/E version 33 and version 34.
2. The project shall be modeled at full output per the project's Interconnection Request.
3. User defined dynamic models must accurately model all the relevant control modes and characteristics of the equipment, such as:

Appendix B Attachment 3

- a. All available voltage/reactive power control modes
  - b. Frequency/governor response control modes
  - c. Voltage and frequency ride-through characteristics
  - d. Power plant controller or group supervisory functionality
  - e. Appropriate aggregate modeling capability
  - f. Charging mode if applicable (e.g., for a battery energy storage device)
4. Dynamic model source code (.flx) or dynamic linked library (.dll), and PSS/E dyr file shall be provided.
  5. User defined dynamic model plant-specific settings shall comply with requirements listed in the Power Purchase Agreement, including ride-through thresholds and other specified control settings if applicable.
  6. User defined dynamic models related to individual units shall be editable in the PSS/E graphic user interface. All model parameters (CONS, ICONS, and VARS) shall be accessible and shall match the description in the model's accompanying documentation.
  7. User defined dynamic models shall have all their data reportable in the "DOCU" listing of dynamics model data, including the range of CONS, ICONS, and VARS numbers. Models that apply to multiple elements (e.g., park controllers) shall also be fully formatted and reportable in DOCU.
  8. User defined dynamic models shall be capable of correctly initializing and run through the simulation throughout the range of expected steady state starting conditions without additional manual adjustments.
  9. User defined dynamic models shall be capable of allowing all documented (in the model documentation) modes of operation without error.
  10. User defined dynamic model shall be accompanied by the following documentation:
    - a. A user's guide for each model
    - b. Appropriate procedures and considerations for using the model in dynamic simulations
    - c. Technical description of characteristics of the model
    - d. Block diagram for the model, including overall modular structure and block diagrams of any sub-modules
    - e. List of plant-specific settings, which may include:
      - i. Ride-through thresholds and parameters
      - ii. Plant-level voltage controller settings
      - iii. Power ramp rate settings
      - iv. ICON flag parameters for specific control modes
      - v. Deadbands
      - vi. Initial State of Charge (SOC)
    - f. Values, names and detailed explanation for all model parameters
    - g. List of all state variables, including expected ranges of values for each variable

## 2.5 Requirements for generation facility generic PSS/E dynamic model

The submitted generic PSS/E dynamic model should meet the following requirements:

1. All generic PSS/E dynamic models must be standard library models in PSS/E.



Appendix B Attachment 3

2. The generation facility PSS/E dynamic model shall be provided for both PSS/E version 33 and version 34.
3. The project shall be modeled at full output per the project's Interconnection Request.
4. Generic dynamic models must accurately model all the relevant control modes and characteristics of the equipment, such as:
  - a. All available voltage/reactive power control modes
  - b. Frequency/governor response control modes
  - c. Voltage and frequency ride-through characteristics
  - d. Power plant controller or group supervisory functionality
  - e. Appropriate aggregate modeling capability
  - f. Charging mode if applicable (e.g., for a battery energy storage device)
5. PSS/E dyr file shall be provided.
6. Generic dynamic models' plant-specific settings should comply with requirements listed in the Power Purchase Agreement, including ride-through thresholds and other specified control settings if applicable.
7. Generic dynamic models shall be capable of correctly initializing and run through the simulation throughout the range of expected steady state starting conditions without additional manual adjustments.
8. Generic dynamic models shall be accompanied by the following documentation:
  - a. A user's guide for each model
  - b. Appropriate procedures and considerations for using the model in dynamic simulations
  - c. Technical description of characteristics of the model
  - d. List of plant-specific settings, which may include:
    - i. Ride-through thresholds and parameters
    - ii. Plant-level voltage controller settings
    - iii. Power ramp rate settings
    - iv. ICON flag parameters for specific control modes
    - v. Deadbands
    - vi. Initial State of Charge (SOC)

## 2.6 Requirements for generation facility ASPEN model

Besides the general requirements, validation results of single phase and three-phase fault current from the generation unit represented in the generation facility ASPEN model shall be provided.

## **3** GENERATION FACILITY TECHNICAL MODEL REVIEW PROCESS

---

To review the generation facility technical model, the following procedures are performed in the PSCAD and PSS/E environment. A review of the results will be documented and provided to the Customer for confirmation of model acceptance or further model updates.

### **3.1 Model review in PSCAD**

- 1) Review model data against “Technical memo PSCAD requirements V5.pdf” provided by Hawaiian Electric. In this step, it will be determined whether the model is complete, generation facility settings are according to the Power Purchase Agreement, and if the model can be compiled and run without any error.
- 2) Initialization test:  
In this step, the generation facility PSCAD model will be determined whether the model initialization is acceptable. Hawaiian Electric requires that:
  - a. The PSCAD model shall initialize as quickly as possible (e.g. <1-3 seconds) to user defined terminal conditions.
  - b. Project PSCAD model shall initialize properly and that the same power flow and voltage conditions shall be observed between the PSCAD and PSS/E models after initialization.
- 3) Voltage and frequency ride-through tests:  
In this step, the generation facility PSCAD model ride-through performance will be reviewed by performing voltage and frequency ride-through simulations in PSCAD. The review will focus on the generation facility model dynamic response during and after ride-through and generation facility trip time.
- 4) Fault simulation tests:  
Two types of fault tested at the Point of Interconnection bus of the generation facility will be performed in this step.
  - i) 3-phase to ground fault with 6-cycle clearing time (same as the PSS/E ring down model test described in the following section).
  - ii) 1-phase to ground fault simulation with 6-cycle clearing time.

In this test, fault current contribution from the generation facility observed in the simulation will be reviewed by comparing it against the generation facility technical document.

### **3.2 Model review in PSS/E**

- 1) Model data review:  
Review model data based on the requirements for PSS/E power flow and dynamic model provided by Hawaiian Electric. In this step, the review determines whether the model is complete, generation facility settings is according to the PPA, and model can be compiled and run without any error.
- 2) Flat start test:

Appendix B Attachment 3

PSS/E models shall initialize correctly and be capable of successful “flat start” testing using the 20 Second No-Fault simulation: This test consists of a 20 second simulation with no disturbance applied.

3) Ring down test:

PSS/E models shall initialize correctly and be capable of successful “ring down” testing using the 60 Second Disturbance Simulation: This test consists of the application of a 3-phase fault for 6 cycles at POI bus, followed by removal of the fault without any lines being tripped. The simulation is run for 60 seconds to allow the dynamics to settle.

4) Voltage and frequency ride-through tests:

In this step, the generation facility PSS/E model ride-through performance will be reviewed by performing voltage and frequency ride-through simulation in PSS/E. The review will focus on the generation facility model dynamic response during and after ride-through and generation facility trip time.

## 4 TYPICAL ISSUES IDENTIFIED FROM THE FACILITY MODEL SUBMITTALS DURING THE PAST RFP PROCESS

---

1. Missing documentation

Only generation technical facility models are submitted, but no model user manual or any other documentation. Without model documentation, it is very difficult to know the correct procedures of using the technical models and identifying issues during the review.

2. Model incompleteness

Often, the model of a single generation unit, such as an inverter, is submitted instead of model of the whole generation facility, which is insufficient. The model of the generation facility should include models for all equipment listed in the section of "General requirements for all technical models".

3. Settings in the model

Type issues in this category are:

- The PSCAD and PSS/E model ride-through settings are not consistent with the settings defined in the Power Purchase Agreement.
- Generation MW is not set as defined.
- Model is set for 50 Hz instead of 60 Hz

4. Model function issues

Some models do not function as expected during different test scenarios. For example:

- Fault current contribution from the generation facility is higher than what is described in the generation facility datasheet
- Generation level is not stable as settings during the initialization test
- Long time oscillation observed in the ringdown test
- Ride-through performance does not reach requirements defined in the Power Purchase Agreement

## REFERENCE

---

- [1] New England Iso Planning procedure – Interconnection planning procedure for generation and elective transmission upgrades
- [2] ERCOT Planning Guide, 2019
- [3] PJM MOD-032 Steady State, Dynamics, and Short Circuit Modeling Data Requirements and Reporting Procedures Document

## APPENDIX A: SAMPLE OVERLAID GENERATION FACILITY TECHNICAL MODEL OUTPUT PLOT FOR THREE-PHASE FAULT

---

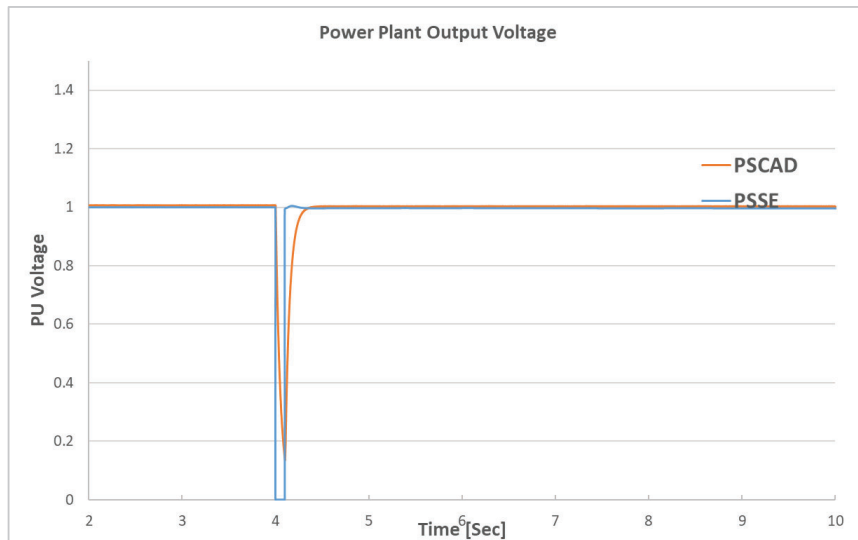

Figure 1: Overlaid plot for power plant voltage

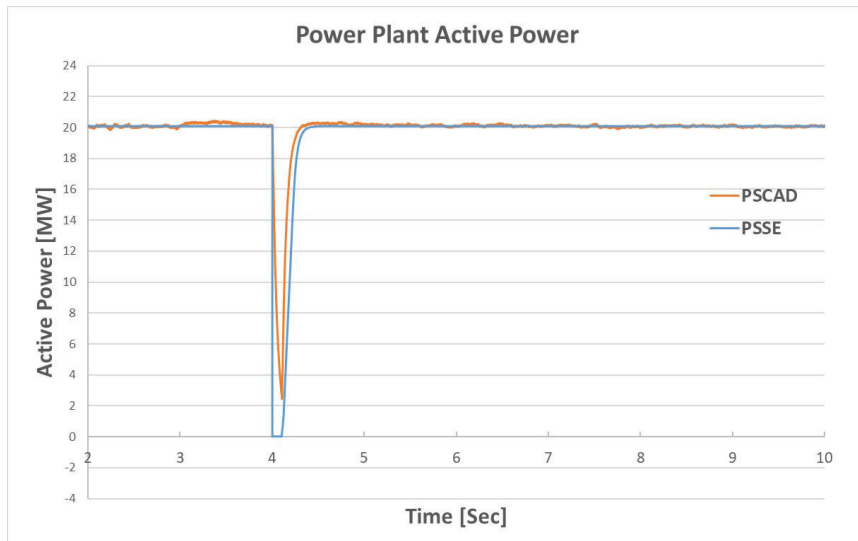

Figure 2: Overlaid plot for power plant active power generation

Appendix B Attachment 3

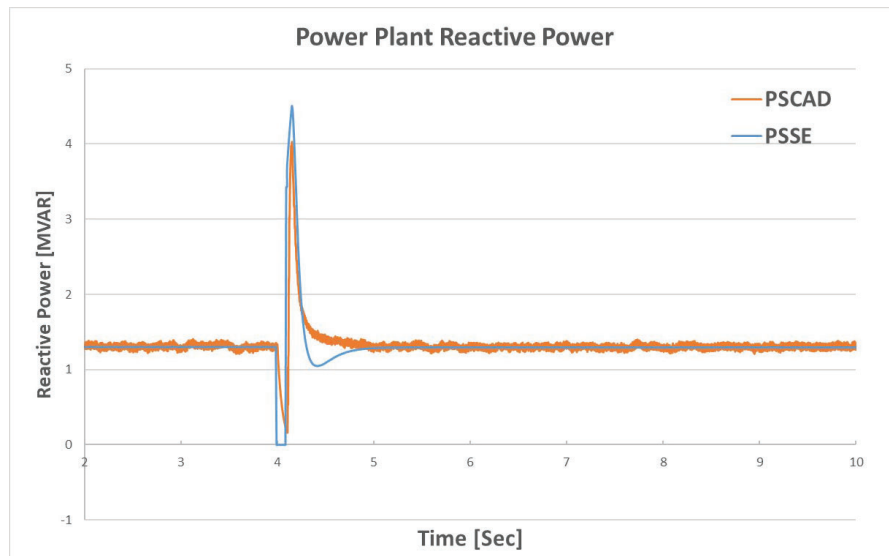

Figure 3: Overlaid plot for power plant reactive power generation

## APPENDIX B: SAMPLE TEST SYSTEM TOPOLOGY INFORMATION

On weak grids such as island systems, it is important to test the models using a representative high Thevenin equivalent impedance.

A typical topology of testing circuit which represents Hawaiian Electric system for 46 kV project is shown in Figure 4. Sample 46 kV Thevenin equivalent impedance is available upon request for model testing.

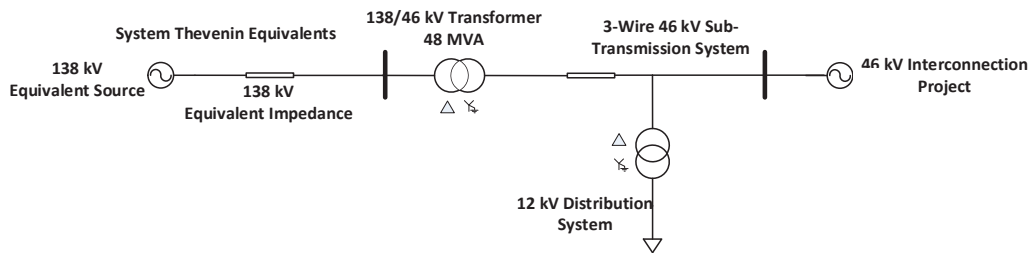

Figure 4: Testing circuit single line diagram for 46 kV project

A typical topology of testing circuit which represents Hawaiian Electric system for 138 kV project is shown in Figure 5. Sample 138 kV Thevenin equivalent impedance is available upon request for model testing.

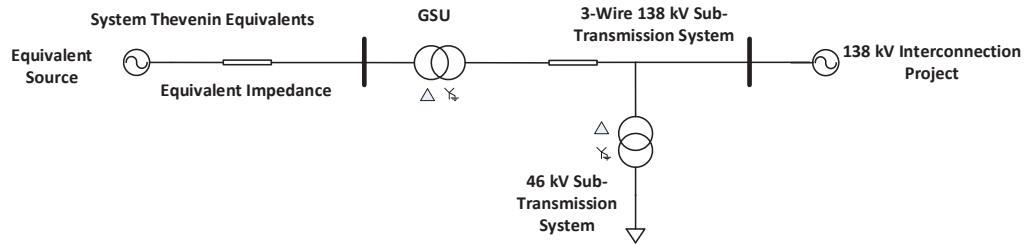

Figure 5: Testing circuit single line diagram for 138 kV project



## PSCAD Model Requirements Rev. 9

**Date:** May 8, 2020  
**Prepared By:** Andrew L. Isaacs  
Lukas Unruh  
Garth Irwin

**This document includes the following attachments:**

**Attachment #1: PSCAD Model Test Checklist**

**Attachment #2: PSCAD Model Requirements Supplier Checklist**

*Electranix makes no representations or warranties of any kind concerning this document, whether express, implied, statutory, or other. This includes, without limitation, warranties of title, merchantability, fitness for a particular purpose, non-infringement, absence of latent or other defects, accuracy, or the presence or absence of errors, whether or not known or discoverable. Electranix will not be held liable for any direct, special, indirect, incidental, consequential, punitive, exemplary, or other losses, costs, expenses, or damages arising out of use of this document or any material herein, even if Electranix has been advised of the possibility of such losses, costs, expenses, or damages.*

Copyright PSCAD Model Requirements Supplier Checklist © 2020 by Electranix Corporation. Please contact [info@electranix.com](mailto:info@electranix.com) for information regarding use or modification of this document.

12-75 Scurfield Blvd.  
Winnipeg, MB, Canada, R3Y 1P6  
[www.electranix.com](http://www.electranix.com)

**ELECTRANIX**  
SPECIALISTS IN POWER SYSTEM STUDIES

This work is licensed under the Creative Commons Attribution 4.0 International License. To view a copy of this license, visit <http://creativecommons.org/licenses/by/4.0/> or send a letter to Creative Commons, PO Box 1866, Mountain View, CA 94042, USA.

### *Introduction*

Specific model requirements for a PSCAD study depend on the type of study being done. A study with a scope covering weak system interconnections, ride-through evaluation, short term<sup>1</sup> event response, and fast control interaction with nearby devices (for example) would require a model which has the following characteristics. Some specialty studies may require other features. Refer to “Attachment #1: PSCAD Model Test Checklist” and “Attachment #2: PSCAD Model Requirements Supplier Checklist”, appended to this document, for additional information on how these requirements may applied.

### *Model Accuracy Features*

For the model to be sufficiently accurate, it must:

- A. *Represent the full detailed inner control loops of the power electronics.* The model cannot use the same approximations classically used in transient stability modeling, and should fully represent all fast inner controls, as implemented in the real equipment. Models which embed the actual hardware code into a PSCAD component are currently wide-spread, and this is the recommended type of model.<sup>2</sup>
- B. *Represent all control features pertinent to the type of study being done.* Examples include external voltage controllers, plant level controllers, customized PLLs, ride-through controllers, SSCI damping controllers and others. As in point A, actual hardware code is recommended to be used for most control and protection features. Operating modes that require system specific adjustment should be user accessible. Plant level voltage control should be represented along with adjustable droop characteristics. If multiple plants are controlled by a common controller, this functionality should be included.
- C. *Represent all pertinent electrical and mechanical configurations.* This includes any filters and specialized transformers. There may be other mechanical features such as gearboxes, pitch controllers, or others which should be modelled if they impact electrical performance within the timeframe of the study. Any control or dynamic features of the actual equipment which may influence behaviour in the simulation period which are not represented or which are approximated should be clearly identified.

---

<sup>1</sup> Example analysis periods could be 2 to 10 seconds from fault inception. Some studies could require longer periods.

<sup>2</sup> The model must be a full IGBT representation (preferred), or may use a voltage source representation that approximates the IGBT switching but maintains full detail in the controls. A three phase sinusoidal source representation is not acceptable. Models manually translated block-by-block from MATLAB or control block diagrams may be unacceptable because the method used to model the electrical network and interface to the controls may not be accurate, or portions of the controls such as PLL circuits or protection circuits may be approximated or omitted. Note that firmware code may be directly used to create an extremely accurate PSCAD model of the controls. The controller source code may be compiled into DLLs or binaries if the source code is unavailable due to confidentiality restrictions.

It is not recommended to assemble the model using standard blocks available in the PSCAD master library, as approximations are usually introduced, and specific implementation details for important control blocks may be lost. In addition, there is a significant risk that errors will be introduced in the process of manually assembling the model. For this type of manually assembled model, (not using a direct “real code” embedding process), extra care is required, and validation is required.

- D. *Have all pertinent protections modeled in detail for both balanced and unbalanced fault conditions.* Typically this includes various OV and UV protections (individual phase and RMS), frequency protections, DC bus voltage protections, converter overcurrent protections, and often other inverter specific protections. As in point A, actual hardware code is recommended to be used for these protection features.
- E. *Be configured to match expected site-specific equipment settings.* Any user-tunable parameters or options should be set in the model to match the equipment at the specific site being evaluated, as far as they are known. Default parameters may not be appropriate.

#### *Model Usability Features*

In order to allow study engineers to perform system analysis using the model, the PSCAD model must:

- F. *Have control or hardware options which are pertinent to the study accessible to the user.* Examples of this could include protection thresholds, real power recovery ramp rates, or SSCI damping controllers.<sup>3</sup> Diagnostic flags (eg. flags to show control mode changes or which protection has been activated) should be visible to aid in analysis.
- G. *Be accurate when running at a simulation time step of 10  $\mu$ s or higher.* Often, requiring a smaller time step means that the control implementation has not used the interpolation features of PSCAD, or is using inappropriate interfacing between the model and the larger network. Lack of interpolation support introduces inaccuracies into the model at larger simulation time-steps. In cases where the IGBT switching frequency is so high that even interpolation does not allow accurate switching representation at 10  $\mu$ s (eg. 40 kHz), an average source approximation of the inverter switching may be used to allow a larger simulation time step<sup>2</sup>.
- H. *Operate at a range of simulation time steps.* The model should not be restricted to operating at a single time step, but should be able to operate within a range (eg. 10  $\mu$ s – 20  $\mu$ s)
- I. *Have the ability to disable protection models.* Many studies result in inadvertent tripping of converter equipment, and the ability to disable protection functions temporarily provides study engineers with valuable system diagnostic information.
- J. *Include documentation and a sample implementation test case.* Test case models should be configured according to the site-specific real equipment configuration up to the Point of Interconnection. This would include (for example): aggregated generator model, aggregated generator transformer, equivalent collector branch, main step up transformers, gen tie line, and any other static or dynamic reactive resources. Test case should use a single machine infinite bus representation of the system, configured with an appropriate representative SCR, such as 2.5. Access to technical support engineers is desirable.
- K. *Have an identification mechanism for configuration.* The model documentation should provide a clear way to identify the specific settings and equipment configuration which will be used in any

---

<sup>3</sup> Care should be taken to ensure that any user-settable options are not changed in a way that is not implementable in the real hardware, and that any selectable options are actually available at the specific site being considered. Discussion is recommended with the manufacturer prior to any changes being made in model configuration.

- study, such that during commissioning the settings used in the studies can be checked. This may be control revision codes, settings files, or a combination of these and other identification measures.
- L. *Accept external reference variables.* This includes real and reactive power ordered values for Q control modes, or voltage reference values for voltage control modes. Model should accept these reference variables for initialization, and be capable of changing these reference variables mid-simulation, ie. dynamic signal references.
  - M. *Be capable of initializing itself.* Once provided with initial condition variables, the model must initialize and ramp to the ordered output without external input from simulation engineers. Any slower control functions which are included (such as switched shunt controllers or power plant controllers) should also accept initial condition variables if required.
  - N. *Have the ability to scale plant capacity.* The active power capacity of the model should be scalable in some way, either internally or through an external scaling transformer<sup>4</sup>. This is distinct from a dispatchable power order, and is used for modeling different capacities of plant or breaking a lumped equivalent plant into smaller composite models.
  - O. *Have the ability to dispatch its output to values less than nameplate.* This is distinct from scaling a plant from one unit to more than one, and is used for testing plant behaviour at various operating points.
  - P. *Initialize quickly.* Model must reach its ordered initial conditions as quickly as possible (for example <5 seconds) to user supplied terminal conditions.

#### *Study Efficiency Features*

In addition, the following elements are required to improve study efficiency, model compatibility, and enable other studies which include the model to be run as efficiently as possible. If these features are not supported, additional discussion is required<sup>5</sup>:

- Q. Model should be compatible with Intel Fortran compiler version 12 and higher.
- R. Model should be compatible with PSCAD version 4.5.3 and higher.
- S. Model supports multiple instances of its own definition in the same simulation case.
- T. Model supports the PSCAD “timed snapshot” feature accessible through project settings.
- U. Model supports the PSCAD “multiple run” feature.
- V. Model does not use or rely upon global variables in the PSCAD environment.
- W. Model should not utilize multiple layers in the PSCAD environment, including ‘disabled’ layers.

---

<sup>4</sup> A free publicly available scaling transformer suitable for this purpose is available in the E-Tran library.

<sup>5</sup> Electrenix has parallelization tools available (E-Tran Plus for PSCAD) which can circumvent compatibility concerns in some cases.

---

## Attachment #1: PSCAD Model Test Checklist

*Electranix makes no representations or warranties of any kind concerning this document, whether express, implied, statutory, or other. This includes, without limitation, warranties of title, merchantability, fitness for a particular purpose, non-infringement, absence of latent or other defects, accuracy, or the presence or absence of errors, whether or not known or discoverable. Electranix will not be held liable for any direct, special, indirect, incidental, consequential, punitive, exemplary, or other losses, costs, expenses, or damages arising out of use of this document or any material herein, even if Electranix has been advised of the possibility of such losses, costs, expenses, or damages.*

Copyright PSCAD Model Requirements Supplier Checklist © 2020 by Electranix Corporation. Please contact [info@electranix.com](mailto:info@electranix.com) for information regarding use or modification of this document.

**Purpose**

This document is a test checklist meant to accompany “PSCAD Model Requirements Rev. 9” provided above and “Attachment #2: PSCAD Model Requirements Supplier Checklist”. The procedures provided in this document are intended to provide an indication of the core model accuracy, performance, and usability features specified in the model requirements. These procedures cannot ultimately prove that the model is compliant with all requirements, as black box models usually hide the details of the equipment controls and protection. It is recommended that the equipment manufacturer supply additional confirmation that the model meets each individual requirement. The requirements in this document do not necessarily represent interconnection criteria for specific individual systems, and may be supplemented or adjusted based on interconnection region.

The tests outlined here are considered “basic”, and may be supplemented by more rigorous testing, including various fault types, depths, and durations, as well as more extensive protection testing and benchmarking against phasor models. This document is not intended to be a guide for thorough benchmarking between PSCAD, PSS/E, and actual equipment, and is subject to revision as the state of the art in EMT modeling evolves.

<i>Model test Summary</i>	
Model Test date:	
Project Name:	
Manufacturer:	
Equipment type: (eg. PV or Wind)	
Equipment version:	
Documentation file:	
Model Files supplied:	

### Verification Procedure and Checklist

		Pass/Fail	Comments
<i>Vendor and site specific model verification</i>			
1a	The Vendor's name and the specific version of the model should be clearly observable in the .psc model file.		
1b	Documentation and supporting model filenames should not conflict with model version shown in the .psc model file.		
1c	Model is supplied with a test circuit which is configured for the site specific application. <sup>6</sup>		
<i>"Real Code" model verification</i>			
2a	Controls are black-boxed, and no PSCAD master library control blocks are visible within control circuits. <sup>7</sup> If the model is not based on "real code", a separate validation report is required showing model comparison against hardware tests. <sup>8</sup>		
<i>Model usability verification</i>			
3a	Model uses a timestep greater than 10 $\mu$ s <sup>9</sup>		
3b	Model allows a variation in simulation timestep		
3c	Model compiles using Intel FORTRAN version 12		
3d	Model initializes in 5 seconds or less with a POI level SCR of 2.5. Real power, reactive power, and RMS voltage should reach steady state by this time.		
3e	Model allows multiple instances of itself to be run together in the same case <sup>10</sup>		
<i>Model electrical configuration verification</i>			
4a	Plant level electrical single line diagram (SLD) is included.		

<sup>6</sup> The test circuit should model all relevant electrical components of the plant and contain a system equivalent. Parameters will be assumed to be site-specific, unless there are obvious indications otherwise, such as an incorrect grid base frequency.

<sup>7</sup> Black-boxing of controls to a high level does not guarantee that real-code is embedded into the model, however the visibility of PSCAD master-library control blocks in the inner control loops (PLL, inner current controllers, etc.) suggest that the model is generic in nature. Model documentation may contain information on use of real-code in the model.

<sup>8</sup> All aspects of the controller operation are required to be validated by utilizing a "hardware in loop" platform or other hardware test systems. Model should not be validated against other software models. Validations should include control responses to various types of faults, changes in power and voltage references, changes in system frequency, testing frequency response in sub and super-synchronous ranges, and testing of protection operation. Tests should also be performed under a variety of system strengths, including very weak systems. Other tests may also be required. The validation report is required along with any model updates that result from the more rigorous validation tests.

<sup>9</sup> Models with timesteps less than 10  $\mu$ s may be acceptable in situations where a small timestep does not significantly increase the runtime of the total simulation

<sup>10</sup> Depending on specific application and whether E-Tran Plus for PSCAD is allowed to be used to overcome the limitation, this requirement may be waived.

**PSCAD Model Requirements Rev. 9  
May 8, 2020**



4b	Generator step-up transformer(s) included, with impedance between 5 and 10% on generator base, and matches SLD. <sup>11</sup>		
4c	Lumped collector equivalent(s) included, with total charging equal to between 0.5 and 5% of plant rating, and matches SLD. <sup>11</sup>		
4d	Substation transformer(s) included, rated appropriately for plant size, and impedance between 6 and 12% on transformer base, and matches SLD. <sup>11</sup>		
4e	Model can be scaled to represent any number inverters/turbines, either using a scaling transformer or internal scaling.		
4f	All external devices included in the plant (such as STATCOMs) include appropriate models.		
<i>Plant controller verification</i>			
5a	Model includes power plant controller (PPC)		
5b	PPC accepts an external active power setpoint.		
5c	PPC accepts a voltage setpoint.		
5d	PPC has a mechanism to implement a settable voltage droop.		
5e	Overall plant responds to frequency changes by increasing or decreasing its active power as appropriate. This may be accomplished either at an inverter level or via the PPC. <sup>12</sup>		
5f	Model initializes to the setpoints specified in the PPC. If droops or deadbands are utilized, the initial values may differ from the setpoints. <sup>13</sup>		
5g	If external voltage control devices (STATCOM/DVAR, SVC, MSCs) are included in the plant, ensure that the voltage control of these devices is coordinated with the PPC, with no potential for VAR looping or oscillations.		
<i>Basic performance verification<sup>14</sup></i>			
6a	Instantaneous voltage and current waveforms have minimal distortion, and no oscillations are observed.		

<sup>11</sup> Impedance range is for sanity checking only. Impedances outside this range may be allowed.

<sup>12</sup> Non-compliance with this item may not require model revision as frequency response may not be required in PSCAD models by some utilities. In this case, a description of the under/over frequency response capabilities of the actual equipment should be provided by the manufacturer.

<sup>13</sup> If voltage control with droop is implemented, it is preferred that the PPC model requests an initial Q value to match the voltage setpoint. If no initial Q is requested, the voltage setpoint can be biased by the initial Q before it is sent to the PPC. If a non-zero deadband is included in the voltage controller, the deadband can also be considered in the voltage setpoint sent to the PPC.

<sup>14</sup> Performance testing is recommended with a POI level SCR of 2.5 as this is a representative system condition seen during weak system studies. Testing may be performed at higher SCRs if the stable operating SCR of a model is known to be above 2.5.



**PSCAD Model Requirements Rev. 9  
May 8, 2020**



6b	Model is able to ride-through and recover from a temporary (no line outage or drop in SCR), 6-cycle, zero-impedance, three-phase fault at the high side of the station transformer, with a POI level SCR of 2.5.		
6c	Model responds to a step change in PPC voltage setpoint, reaching 90% of the new value between 1 and 10 seconds in a test system with POI level SCR of 2.5. (Various systems may have specific speed requirements, which should be met)		
6d	Model responds to a step change in PPC active power setpoint, reaching 90% of the new value between 1 and 10 seconds in a test system with POI level SCR of 2.5. <sup>15</sup>		
<i>Basic protection verification</i> <sup>16</sup>			
7a	Protection settings are implemented. These could be available as inputs in the model, or hard-coded in the black-boxed controls. <sup>17</sup>		
7b	Option to disable protection models is present. <sup>18</sup>		
7c	Model trips or blocks when terminal voltage rises above 1.3 pu for 1.5 second. <sup>19</sup>		
7d	Model trips or blocks when terminal voltage falls below 0.2 pu for 1.5 second. <sup>19</sup>		
7e	Model clearly displays trip / diagnostic signals indicating the status of all pertinent protection elements		
<i>Documentation</i>			
8a	Model documentation states compliance with "PSCAD Model Requirements Rev. 9 Rev. 9" <sup>20</sup> , or is supplied with a completed PSCAD Model Requirements Supplier Checklist.		
8b	Model documentation includes instructions for setup and running of the model, including the recommended range of simulation timesteps. Documentation should give a clear description of trip / operation code signals produced by model.		

<sup>15</sup> Different response time criteria may apply depending on specific interconnection region.

<sup>16</sup> There are many protection functions which should be modelled, per footnote 1, and these basic tests will not be proof that these are modelled.

<sup>17</sup> If settings are not visible in model or documentation, verification that protection settings are implemented in the PSCAD model should be received from the manufacturer.

<sup>18</sup> Non-compliance may not require model revision as many studies do not require testing with protection settings disabled.

<sup>19</sup> Non-compliance with this item should result in verification of protection settings implementation from the manufacturer, as some models may have capabilities beyond what is listed here.

<sup>20</sup> Non-compliance may be waived in systems which do not require compliance with the model requirements document.

---

## Attachment #2: PSCAD Model Requirements Supplier Checklist

*Electranix makes no representations or warranties of any kind concerning this document, whether express, implied, statutory, or other. This includes, without limitation, warranties of title, merchantability, fitness for a particular purpose, non-infringement, absence of latent or other defects, accuracy, or the presence or absence of errors, whether or not known or discoverable. Electranix will not be held liable for any direct, special, indirect, incidental, consequential, punitive, exemplary, or other losses, costs, expenses, or damages arising out of use of this document or any material herein, even if Electranix has been advised of the possibility of such losses, costs, expenses, or damages.*

Copyright PSCAD Model Requirements Supplier Checklist © 2020 by Electranix Corporation. Please contact [info@electranix.com](mailto:info@electranix.com) for information regarding use or modification of this document.

## Purpose

This document is a model requirements checklist which should be completed by the supplier of the model and submitted alongside each PSCAD model. This document accompanies the “PSCAD Model Requirements Rev. 9” document above (PMR), which should be used for further reference to describe the requirements associated with each point. Generic testing of the model may be done using “Attachment #1: PSCAD Model Test Checklist”, which may be used as a reference.

Model supplier must review every item in the checklist and indicate compliance for each item. If the supplied model does not meet any of the requirements an explanation of the deficiency should be provided in the comments column.

<i>Model Submission Summary (to be completed by model supplier)</i>	
Submission date:	
Project Name:	
Primary contact information for model related questions:	
Secondary contact information for model related questions:	
Manufacturer:	
Equipment type: (eg. PV or Wind)	
Equipment version:	
Documentation file(s):	
Model Files supplied:	



**Recommended PSCAD Model Requirements Rev. 9  
May 8, 2020**

Model Requirements Checklist				Model Complies? (Yes/No)	Comments
<b>1 Model Accuracy Features</b>					
1.1	Power electronic controls are modelled by interfacing with actual firmware code from the inverter (“real code” model), or includes detailed validation report.	A, B			
1.2	Operating modes which require system specific adjustment are accessible.	B			
1.3	Plant level controller is included. <sup>21</sup>	B			
1.4	Model is capable of controlling frequency <sup>22</sup>	B			
1.5	Includes pertinent electrical and mechanical features, such as gearboxes, pitch controllers, or other features which impact the plant performance in the simulation period. <sup>23</sup>	C			
1.6	All protections which could impact ride-through performance are modelled in detail.	D			
1.7	Model is configured for the specific site being evaluated, as far as they are known.	E			
<b>2 Model and Project Documentation</b>					
2.1	Model includes documentation.	J			
2.2	Documentation includes instruction for setup and running the model.	J			

<sup>21</sup> If the plant is part of a multi-plant control scheme, a description of the overall scheme should be provided, and corresponding PPC models should be configured to control multiple plants accordingly.

<sup>22</sup> Frequency control model requirements may vary by region. Example response time may be less than 10 seconds.

<sup>23</sup> Simulation period may vary depending on the model use, but 10 seconds of simulation following an event such as a fault is a typical period.

This work is licensed under the Creative Commons Attribution 4.0 International License. To view a copy of this license, visit <http://creativecommons.org/licenses/by/4.0/> or send a letter to Creative Commons, PO Box 1866, Mountain View, CA 94042, USA.



**Recommended PSCAD Model Requirements Rev. 9  
May 8, 2020**

2.3	Model is supplied with a sample test case including site specific plant representation.	J	
2.4	Plant single line diagram is provided, and aligns with model	J	
2.5	Model documentation provides a clear way to identify site-specific settings and equipment configuration.	K	
<b>3</b>	<b><i>Model Usability Features</i></b>		
3.01	Control or hardware options are accessible to the user as applicable.	F	
3.02	Diagnostic flags are visible to the user.	F	
3.03	Model uses a timestep greater than 10 μs.	G	
3.04	Model allows a range of simulation timesteps (ie. not restricted to a single timestep).	H	
3.05	Protection model may be disabled for troubleshooting	I	
3.06	Model accepts external reference variables for active and reactive power and voltage setpoint, and these may be changed dynamically during the simulation.	L	
3.07	Model is capable of initializing itself.	M	
3.08	Active power capacity is scalable.	N	
3.09	Active power is dispatchable.	O	
3.10	Model reaches setpoint P, Q, and V in 5 seconds or less	P	
3.11	Model compatible with Intel FORTRAN version 12 and higher.	Q	
3.12	Model compiles using PSCAD version 4.5.3 or higher.	R	
3.13	Model supports multiple instances of its own definition in a single PSCAD case.	S	
3.14	Model supports PSCAD “snapshot” feature.	T	

This work is licensed under the Creative Commons Attribution 4.0 International License. To view a copy of this license, visit <http://creativecommons.org/licenses/by/4.0/> or send a letter to Creative Commons, PO Box 1866, Mountain View, CA 94042, USA.

**Recommended PSCAD Model Requirements Rev. 9  
 May 8, 2020**



3.15	Model supports the PSCAD “multiple run” feature.	U	
3.16	Model does not use PSCAD global variables.	V	
3.17	Model does not use PSCAD layer functionality	W	

---

This work is licensed under the Creative Commons Attribution 4.0 International License. To view a copy of this license, visit <http://creativecommons.org/licenses/by/4.0/> or send a letter to Creative Commons, PO Box 1866, Mountain View, CA 94042, USA.



Transmission and Distribution Planning Division - Interconnection Services Department  
Simulation Tests  
CBRE RFP Interconnection Requirement Study-System Impact Study  
Date: July 7, 2020

---

## 1. Introduction

This document describes the simulation tests that Hawaiian Electric IRS study consultants will perform to check the models submitted for CBRE IRS. Results of these tests, combined with other checks on project input data and model parameters, will determine if the models are acceptable for the IRS studies. The models to be tested are PSS E user-written model, PSCAD model and ASPEN short-circuit model for each project.

It is recommended that the model submitters should also perform these tests to self-check on your models, so that your models will become acceptable for the IRS study in a timely manner.

## 2. Separate Models Required for Grid Following Mode and Grid Forming Mode

For the CBRE IRS, modeling of inverter Grid Forming capabilities may be required. For each project, separate models should be submitted: one with the project in Grid Forming (GFM) mode (if applicable), and the other with the project in Grid Following (GFL) mode. This requirement applies to all models mentioned above.

## 3. General Requirements

All submitted models should be accompanied by proper documentation.

There should be a reasonable match between the PSS E user-written model and the PSCAD model responses for the simulation tests performed for both models.

## 4. List of Simulation Tests

### 4.1 GFL Mode Simulation Tests

#### 4.1.1 Tests to be performed for PSS E models

- a. Flat run in a two-machine system (one machine is a synchronous machine, e.g., GENCLS model, and the other machine is a project's model.)
- b. Ringdown (3ph-ground fault simulation test) in a two-machine system.



***GFL-Tests to be performed for PSS E models - continued***

- c. Voltage ride-through and response in a two-machine system.
- d. Frequency ride-through and response in a two-machine system.
- e. Weak grid operation in a two-machine system  
Gradually increase/decrease MVA of the synchronous machine within a range and check if the project's model is able to work with the studied MVA range.
- f. Simulation in a relevant HECO island system model for a couple of selected faults  
The purpose here is to identify potential issues with a project's PSS E model ahead of dynamic stability analysis to limit study delays due to model issues.

Note: also refer to "Siemens PTI Model Review process\_200317.pdf".

***4.1.2 Tests to be performed for PSCAD models only (includes model adequacy and documentation checks)***

- g. Tests and checks outlined in "PSCAD Requirements Rev 9 May 2020.pdf", inclusive of ringdown, voltage and frequency ride-through tests.





## 4.2 GFM Mode Simulation Tests

### 4.2.1 Tests to be performed for both PSS E and PSCAD models

Test notes:

- Applicable for projects which include grid-forming BESS only
  - Assumption is that BESS has available energy and is dispatched suitably for the tests (i.e. Not at current limit)
- a. Able to black start and operate in island mode

Test sequence: energize main power transformer from project side, then connect project to a load, then apply a bus fault at the POI, then remove the fault. Results: voltage and frequency should be stable and settle back to close to their nominal values after the disturbances.

- b. Loss of the last synchronous machine

Test system will be a three-machine system including: a synchronous machine modeled by GENROU with a simple excitation system model (e.g., SCRX) and a simple governor model (e.g., TGOV1), a load with both real and reactive components, and duplicates of a project's model. Duplicates of a project's model are utilized here to check if the project is able to share real and reactive power properly with other generators. Test event: trip the synchronous generator. Results: voltage and frequency should be stable and settle back to close to their nominal values after the disturbance.

- c. Weak grid operation

Test system is the two-machine system. Gradually increase/decrease MVA of the synchronous machine within a range and check if the project's model is able to work with the studied MVA range.

- d. Able to operate in harmony with other converter resources and synchronous machines

Test system is the three-machine system including: a synchronous machine modeled by GENROU with a simple excitation system model and a simple governor model, a load with both real and reactive components, and duplicates of a project's model. Simulation tests to be performed may include load step up/down, ringdown, voltage ride through and frequency ride-through tests. Results: voltage and frequency should be stable and settle back to close to their nominal values after the disturbances.



***GFM Mode Simulation Tests – Tests to be performed for both PSS E and PSCAD models - continued***

Particularly related to frequency control characteristics, we will test for configurable frequency droop control and configurable deadband characteristics. The frequency deadband should be settable in the range from +/- 0.01 Hz to +/- 1.0 Hz and the frequency droop shall be settable in the range of 0.1% to 10% with a typical value of 4%. A sample characteristic of frequency droop control with deadband is shown in Figure 1.

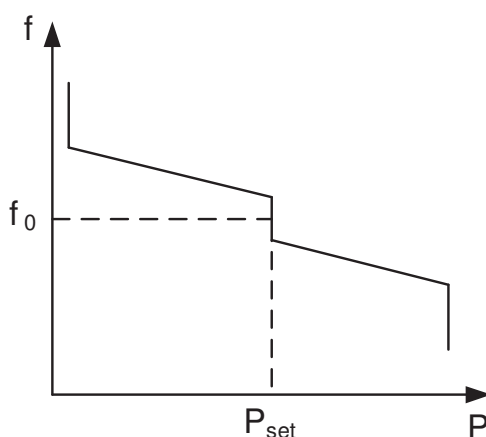

**Figure 1 – Frequency Droop Control Characteristic with Deadband**

- e. Switching between GFL mode and GFM mode

Test system is the two-machine system. Test sequence: energize main power transformer from project side, then connect project to a load. At this point, the project will be operating in island mode, performing frequency control. Then switch in the synchronous generator; the project will be operating in power/frequency droop control mode. Results: voltage and frequency should be stable and settle back to close to their nominal values after the disturbances.

**4.2.2 Tests to be performed for PSS E models only**

- a. Reduction in frequency deviation in GFM mode

Test system will be a relevant HECO island system model. Test event is loss of a large generator. Project model will be in GFL mode and GFM mode. Result: less degree of frequency deviation is expected when project is in GFM mode than when the project is in GFL mode.



#### 4.3 ASPEN Model Check

A review of the ASPEN models will be performed. As mentioned above, two models are expected for each project: one model for GFL mode, and the other for GFM mode. Documentation associated with the models should be provided. The model review will check if the components of a project are modeled properly, such as transformers, equivalent collector system, equivalent generator, etc., and that the model data are consistent to the PSS E and PSCAD model data. A fault simulation test will also be performed in a two-machine system. Total current at the fault location and contribution from each machine will be reviewed and documented.



**Siemens Industry, Inc.**  
**Siemens Power Technologies International**  
 4000 East Third Avenue - Suite 400  
 Foster City, CA 94404 USA  
 Tel: +1 (650) 772-2289  
 www.siemens.com/power-technologies

**Date:** March 17, 2020

**From:** Osazuwa Oriakhi, Wenchun Zhu and Kavita Sheno, Siemens PTI

**RE: HECO IRS Model Review Process**

Message from Interconnection Services: This document shows you an example of the model data review and tests that a study consultant performs on your model data submittal under the Interconnection Requirement Study, System Impact Study (IRS SIS Agreement). The Test Package that you are receiving is repeated for the IRS. By performing these tests as a Do-it-Yourself (DIY), model data submittals when we receive them for the IRS SIS are understood to be accurate and have usability and efficiency features to integrate the facility model data with the Company's system model data and commence the IRS SIS analyses in a prompt and efficient manner.

Siemens PTI performs the following data checks and tests as a part of our Model review process.

**A. Steady State Data Review**

Siemens PTI will review the ratings and impedances of all equipment in the ASPEN, PSS®E and PSCAD models and check for discrepancies. Table 1 below shows the comparison of power flow data for all equipment in the PSS®E and PSCAD models.

**Table 1. Steady State Data Review**

Equipment	Comments
Gen-Tie line	PSS®E, PSCAD and ASPEN models should match
Main Power Transformer Impedance	PSS®E, PSCAD and ASPEN models should match
Main Power Transformer Configuration	PSCAD and ASPEN models should match
PV Collector System Data	PSS®E, PSCAD and ASPEN models should match
BESS Collector System Data	PSS®E, PSCAD and ASPEN models should match
Inverter Pad Mount Transformer Impedance	PSS®E, PSCAD and ASPEN models should match
Inverter Pad Mount Transformer Configuration	PSCAD and ASPEN models should match
Inverter Power Flow Data	PSS®E and PSCAD models should match
Voltage Control Point	PSS®E and PSCAD models should match

*This document was prepared by Siemens Industry, Inc., Siemens Power Technologies International (Siemens PTI), solely for the benefit of the recipient named in this memorandum. Siemens PTI nor any party acting on its behalf (a) makes any warranty, expressed or implied, with respect to the use of any information or methods disclosed in this document; or (b) assumes any liability with respect to the use of any information or methods disclosed in this document. Any party other than the named recipient of this memorandum, by their acceptance or use of this document, releases Siemens PTI from any liability for direct, indirect, consequential or special loss or damage whether arising in contract, warranty, express or implied, tort or otherwise, and irrespective of fault, negligence, and strict liability.*

**B. Dynamic Model Data Review**

There are three types of models which show the transient/dynamic behavior of the generation facility:

1. A PSS®E user-written dynamic model which is a detailed model of the specific inverters and controls provided by the manufacturer.
2. A PSS®E generic model which utilizes PSS®E library models to specify the dynamic behavior of the facility.
3. A PSCAD model which is a detailed transient model of the inverters and controls

Siemens PTI will compare the various dynamic model parameters across the three models and note any discrepancies in the data fields shown in Table 2.

**Table 2. Comparison of Dynamic Model Parameters**

Parameters	Comments
Power Plant Controller (PPC)	Review number of PPCs
Control Flags	PSS®E and PSCAD control flags should match.
Control Bus/Point of Measurement	Control buses should match in PSS®E and PSCAD models.
Frequency Control Dead Band	The frequency thresholds for primary and secondary control should match in the PSCAD and PSS®E models.
Initial State of Charge (SOC)	Make sure the initial state of charge is set up correctly to prevent initialization issues.
Voltage and Frequency Ride Through Settings	The voltage and frequency ride through settings should match in the PSS®E user-written, PSS®E generic and PSCAD models.
P/Q priority data	The P/Q priority flags should match in the PSS®E user-written, PSS®E generic and PSCAD models

**C. Model tests**

Siemens PTI will perform the following tests to check the active power, reactive power, voltage and frequency responses of the generation facility and review if the three models (PSS®E user-written, PSS®E generic and PSCAD models) show consistent responses.

1. **Flat Run Test:** This is a no-disturbance simulation to check a model's initialization. This test is applicable to all three types of models.
2. **Ring Down Test:** In this simulation, a fault is placed at the facility's POI for a duration of 6-cycles. The fault is subsequently cleared, and the post-disturbance response of the facility is observed. This test is applicable to all three types of models.
3. **High and Low Frequency Response Test:** In these simulations, the system frequency is varied to test the facility's responses to grid's frequency excursions. In the PSS®E tests, high and low frequency excursions are simulated to mimic the frequency ride through thresholds specified in the PPA and the response of the facility is observed. Both the frequency ride-through capability of the facility and its active power response to frequency excursions are tested in the PSS®E simulations.

In the PSCAD simulations, the focus is on testing the facility's active power responses to frequency excursions, and not on testing the frequency ride-through capability. However, it should be noted that the duration of the frequency excursions in the PSCAD tests are well-

Appendix B Attachment 3

within the no-trip zones according to the PPA, and so the facility is not expected to trip during these simulations. Table 3 and Table 4 show the frequency excursions that were simulated in the PSCAD tests.

**Table 3 Frequency Excursions for PSCAD High Frequency Response Test**

Frequency level (Hz)	Duration (secs)
60.1	2.0
63.0	2.0

**Table 4 Frequency Excursions for PSCAD Low Frequency Response Test**

Frequency level (Hz)	Duration (secs)
59.9	2.0
56.0	2.0

4. **High and Low Voltage Ride-through and Response Tests:** In these simulations, the POI voltage is varied to test the facility's ride-through capabilities and responses to POI voltage excursions. In the PSS<sup>®</sup>E simulations, two sets of tests are performed: one for testing the ride-through capabilities and the other for testing the responses to voltage excursions. These two sets of tests are similar, except that the grid equivalent representation is different. For the ride-through tests, the grid equivalent is represented by a generator with a very large MVA, which connects to the POI bus directly. For the voltage excursion response tests, the grid equivalent is represented by a 500 MVA generator which connects to the POI through a branch with a reactance of 0.1 p.u.

In the PSCAD simulations, the focus is on testing the facility's reactive power responses to POI voltage excursions, and not on testing the voltage ride-through capability. However, it should be noted that the duration of the voltage excursions in the PSCAD tests are well-within the no-trip zones according to the PPA, and so the facility is not expected to trip during these simulations.

Table 5 shows the voltage excursions that will be simulated in the PSCAD tests.

**Table 5 POI Voltage Excursions for PSCAD Voltage Response Test**

POI Voltage level (pu)	Duration (secs)
1.20	0.8
1.10	2.0
0.88	2.0
0.70	2.0

Each of the above discussed tests were performed for the following three generation dispatches:

- **PV output only:** In this dispatch, the PV unit is at maximum output and the BESS unit is online at 0 MW.
- **BESS output only:** In this dispatch, the BESS unit is discharging at maximum output and the PV unit is online at 0 MW.

Appendix B Attachment 3

- **PV charging BESS:** In this dispatch, the PV unit is at its maximum output and is charging the BESS at its minimum level.

**D. Expected Model Performance**

1. Matching steady-state model parameters between the PSS®E user-written, generic models and the PSCAD model.
2. Matching control options between the three types of models.
3. Matching voltage and frequency ride-through parameters between the three types of models. The settings should meet the ride-through requirements specified in the PPA.
4. Flat run results do not show any movement for any of the three models.
5. Ring-down simulation results show stable and proper responses, and the responses from the three models should show reasonable matches.
6. Ride-through simulation results should show stable and proper responses, and the responses should show reasonable matches. The ride through performance should meet the PPA requirements.

**E. Model Review Reporting Requirements**

1. Simulation tests should be performed using the python scripts provided by Siemens PTI, and should be readily reproducible.
2. Discuss model review results.
3. Include simulation plots for the simulation tests discussed above.
4. Related to high and low frequency ride through tests, document frequency response droops shown in the simulations.

## PSCAD Model Requirements Rev. 9

**Date:** May 8, 2020  
**Prepared By:** Andrew L. Isaacs  
Lukas Unruh  
Garth Irwin

**This document includes the following attachments:**

**Attachment #1: PSCAD Model Test Checklist**

**Attachment #2: PSCAD Model Requirements Supplier Checklist**

*Electranix makes no representations or warranties of any kind concerning this document, whether express, implied, statutory, or other. This includes, without limitation, warranties of title, merchantability, fitness for a particular purpose, non-infringement, absence of latent or other defects, accuracy, or the presence or absence of errors, whether or not known or discoverable. Electranix will not be held liable for any direct, special, indirect, incidental, consequential, punitive, exemplary, or other losses, costs, expenses, or damages arising out of use of this document or any material herein, even if Electranix has been advised of the possibility of such losses, costs, expenses, or damages.*

Copyright PSCAD Model Requirements Supplier Checklist © 2020 by Electranix Corporation. Please contact [info@electranix.com](mailto:info@electranix.com) for information regarding use or modification of this document.

12-75 Scurfield Blvd.  
Winnipeg, MB, Canada, R3Y 1P6  
[www.electranix.com](http://www.electranix.com)

**ELECTRANIX**  
SPECIALISTS IN POWER SYSTEM STUDIES

This work is licensed under the Creative Commons Attribution 4.0 International License. To view a copy of this license, visit <http://creativecommons.org/licenses/by/4.0/> or send a letter to Creative Commons, PO Box 1866, Mountain View, CA 94042, USA.



### *Introduction*

Specific model requirements for a PSCAD study depend on the type of study being done. A study with a scope covering weak system interconnections, ride-through evaluation, short term<sup>1</sup> event response, and fast control interaction with nearby devices (for example) would require a model which has the following characteristics. Some specialty studies may require other features. Refer to “Attachment #1: PSCAD Model Test Checklist” and “Attachment #2: PSCAD Model Requirements Supplier Checklist”, appended to this document, for additional information on how these requirements may applied.

### *Model Accuracy Features*

For the model to be sufficiently accurate, it must:

- A. *Represent the full detailed inner control loops of the power electronics.* The model cannot use the same approximations classically used in transient stability modeling, and should fully represent all fast inner controls, as implemented in the real equipment. Models which embed the actual hardware code into a PSCAD component are currently wide-spread, and this is the recommended type of model.<sup>2</sup>
- B. *Represent all control features pertinent to the type of study being done.* Examples include external voltage controllers, plant level controllers, customized PLLs, ride-through controllers, SSCI damping controllers and others. As in point A, actual hardware code is recommended to be used for most control and protection features. Operating modes that require system specific adjustment should be user accessible. Plant level voltage control should be represented along with adjustable droop characteristics. If multiple plants are controlled by a common controller, this functionality should be included.
- C. *Represent all pertinent electrical and mechanical configurations.* This includes any filters and specialized transformers. There may be other mechanical features such as gearboxes, pitch controllers, or others which should be modelled if they impact electrical performance within the timeframe of the study. Any control or dynamic features of the actual equipment which may influence behaviour in the simulation period which are not represented or which are approximated should be clearly identified.

---

<sup>1</sup> Example analysis periods could be 2 to 10 seconds from fault inception. Some studies could require longer periods.

<sup>2</sup> The model must be a full IGBT representation (preferred), or may use a voltage source representation that approximates the IGBT switching but maintains full detail in the controls. A three phase sinusoidal source representation is not acceptable. Models manually translated block-by-block from MATLAB or control block diagrams may be unacceptable because the method used to model the electrical network and interface to the controls may not be accurate, or portions of the controls such as PLL circuits or protection circuits may be approximated or omitted. Note that firmware code may be directly used to create an extremely accurate PSCAD model of the controls. The controller source code may be compiled into DLLs or binaries if the source code is unavailable due to confidentiality restrictions.

It is not recommended to assemble the model using standard blocks available in the PSCAD master library, as approximations are usually introduced, and specific implementation details for important control blocks may be lost. In addition, there is a significant risk that errors will be introduced in the process of manually assembling the model. For this type of manually assembled model, (not using a direct “real code” embedding process), extra care is required, and validation is required.

- D. *Have all pertinent protections modeled in detail for both balanced and unbalanced fault conditions.* Typically this includes various OV and UV protections (individual phase and RMS), frequency protections, DC bus voltage protections, converter overcurrent protections, and often other inverter specific protections. As in point A, actual hardware code is recommended to be used for these protection features.
- E. *Be configured to match expected site-specific equipment settings.* Any user-tunable parameters or options should be set in the model to match the equipment at the specific site being evaluated, as far as they are known. Default parameters may not be appropriate.

#### *Model Usability Features*

In order to allow study engineers to perform system analysis using the model, the PSCAD model must:

- F. *Have control or hardware options which are pertinent to the study accessible to the user.* Examples of this could include protection thresholds, real power recovery ramp rates, or SSCI damping controllers.<sup>3</sup> Diagnostic flags (eg. flags to show control mode changes or which protection has been activated) should be visible to aid in analysis.
- G. *Be accurate when running at a simulation time step of 10  $\mu$ s or higher.* Often, requiring a smaller time step means that the control implementation has not used the interpolation features of PSCAD, or is using inappropriate interfacing between the model and the larger network. Lack of interpolation support introduces inaccuracies into the model at larger simulation time-steps. In cases where the IGBT switching frequency is so high that even interpolation does not allow accurate switching representation at 10  $\mu$ s (eg. 40 kHz), an average source approximation of the inverter switching may be used to allow a larger simulation time step<sup>2</sup>.
- H. *Operate at a range of simulation time steps.* The model should not be restricted to operating at a single time step, but should be able to operate within a range (eg. 10  $\mu$ s – 20  $\mu$ s)
- I. *Have the ability to disable protection models.* Many studies result in inadvertent tripping of converter equipment, and the ability to disable protection functions temporarily provides study engineers with valuable system diagnostic information.
- J. *Include documentation and a sample implementation test case.* Test case models should be configured according to the site-specific real equipment configuration up to the Point of Interconnection. This would include (for example): aggregated generator model, aggregated generator transformer, equivalent collector branch, main step up transformers, gen tie line, and any other static or dynamic reactive resources. Test case should use a single machine infinite bus representation of the system, configured with an appropriate representative SCR, such as 2.5. Access to technical support engineers is desirable.
- K. *Have an identification mechanism for configuration.* The model documentation should provide a clear way to identify the specific settings and equipment configuration which will be used in any

---

<sup>3</sup> Care should be taken to ensure that any user-settable options are not changed in a way that is not implementable in the real hardware, and that any selectable options are actually available at the specific site being considered. Discussion is recommended with the manufacturer prior to any changes being made in model configuration.

- study, such that during commissioning the settings used in the studies can be checked. This may be control revision codes, settings files, or a combination of these and other identification measures.
- L. *Accept external reference variables.* This includes real and reactive power ordered values for Q control modes, or voltage reference values for voltage control modes. Model should accept these reference variables for initialization, and be capable of changing these reference variables mid-simulation, ie. dynamic signal references.
  - M. *Be capable of initializing itself.* Once provided with initial condition variables, the model must initialize and ramp to the ordered output without external input from simulation engineers. Any slower control functions which are included (such as switched shunt controllers or power plant controllers) should also accept initial condition variables if required.
  - N. *Have the ability to scale plant capacity.* The active power capacity of the model should be scalable in some way, either internally or through an external scaling transformer<sup>4</sup>. This is distinct from a dispatchable power order, and is used for modeling different capacities of plant or breaking a lumped equivalent plant into smaller composite models.
  - O. *Have the ability to dispatch its output to values less than nameplate.* This is distinct from scaling a plant from one unit to more than one, and is used for testing plant behaviour at various operating points.
  - P. *Initialize quickly.* Model must reach its ordered initial conditions as quickly as possible (for example <5 seconds) to user supplied terminal conditions.

#### *Study Efficiency Features*

In addition, the following elements are required to improve study efficiency, model compatibility, and enable other studies which include the model to be run as efficiently as possible. If these features are not supported, additional discussion is required<sup>5</sup>:

- Q. Model should be compatible with Intel Fortran compiler version 12 and higher.
- R. Model should be compatible with PSCAD version 4.5.3 and higher.
- S. Model supports multiple instances of its own definition in the same simulation case.
- T. Model supports the PSCAD “timed snapshot” feature accessible through project settings.
- U. Model supports the PSCAD “multiple run” feature.
- V. Model does not use or rely upon global variables in the PSCAD environment.
- W. Model should not utilize multiple layers in the PSCAD environment, including ‘disabled’ layers.

---

<sup>4</sup> A free publicly available scaling transformer suitable for this purpose is available in the E-Tran library.

<sup>5</sup> Electrenix has parallelization tools available (E-Tran Plus for PSCAD) which can circumvent compatibility concerns in some cases.

---

## Attachment #1: PSCAD Model Test Checklist

*Electranix makes no representations or warranties of any kind concerning this document, whether express, implied, statutory, or other. This includes, without limitation, warranties of title, merchantability, fitness for a particular purpose, non-infringement, absence of latent or other defects, accuracy, or the presence or absence of errors, whether or not known or discoverable. Electranix will not be held liable for any direct, special, indirect, incidental, consequential, punitive, exemplary, or other losses, costs, expenses, or damages arising out of use of this document or any material herein, even if Electranix has been advised of the possibility of such losses, costs, expenses, or damages.*

Copyright PSCAD Model Requirements Supplier Checklist © 2020 by Electranix Corporation. Please contact [info@electranix.com](mailto:info@electranix.com) for information regarding use or modification of this document.

## Purpose

This document is a test checklist meant to accompany “PSCAD Model Requirements Rev. 9” provided above and “Attachment #2: PSCAD Model Requirements Supplier Checklist”. The procedures provided in this document are intended to provide an indication of the core model accuracy, performance, and usability features specified in the model requirements. These procedures cannot ultimately prove that the model is compliant with all requirements, as black box models usually hide the details of the equipment controls and protection. It is recommended that the equipment manufacturer supply additional confirmation that the model meets each individual requirement. The requirements in this document do not necessarily represent interconnection criteria for specific individual systems, and may be supplemented or adjusted based on interconnection region.

The tests outlined here are considered “basic”, and may be supplemented by more rigorous testing, including various fault types, depths, and durations, as well as more extensive protection testing and benchmarking against phasor models. This document is not intended to be a guide for thorough benchmarking between PSCAD, PSS/E, and actual equipment, and is subject to revision as the state of the art in EMT modeling evolves.

<i>Model test Summary</i>	
Model Test date:	
Project Name:	
Manufacturer:	
Equipment type: (eg. PV or Wind)	
Equipment version:	
Documentation file:	
Model Files supplied:	

### Verification Procedure and Checklist

		Pass/Fail	Comments
<i>Vendor and site specific model verification</i>			
1a	The Vendor's name and the specific version of the model should be clearly observable in the .psc model file.		
1b	Documentation and supporting model filenames should not conflict with model version shown in the .psc model file.		
1c	Model is supplied with a test circuit which is configured for the site specific application. <sup>6</sup>		
<i>"Real Code" model verification</i>			
2a	Controls are black-boxed, and no PSCAD master library control blocks are visible within control circuits. <sup>7</sup> If the model is not based on "real code", a separate validation report is required showing model comparison against hardware tests. <sup>8</sup>		
<i>Model usability verification</i>			
3a	Model uses a timestep greater than 10 $\mu$ s <sup>9</sup>		
3b	Model allows a variation in simulation timestep		
3c	Model compiles using Intel FORTRAN version 12		
3d	Model initializes in 5 seconds or less with a POI level SCR of 2.5. Real power, reactive power, and RMS voltage should reach steady state by this time.		
3e	Model allows multiple instances of itself to be run together in the same case <sup>10</sup>		
<i>Model electrical configuration verification</i>			
4a	Plant level electrical single line diagram (SLD) is included.		

<sup>6</sup> The test circuit should model all relevant electrical components of the plant and contain a system equivalent. Parameters will be assumed to be site-specific, unless there are obvious indications otherwise, such as an incorrect grid base frequency.

<sup>7</sup> Black-boxing of controls to a high level does not guarantee that real-code is embedded into the model, however the visibility of PSCAD master-library control blocks in the inner control loops (PLL, inner current controllers, etc.) suggest that the model is generic in nature. Model documentation may contain information on use of real-code in the model.

<sup>8</sup> All aspects of the controller operation are required to be validated by utilizing a "hardware in loop" platform or other hardware test systems. Model should not be validated against other software models. Validations should include control responses to various types of faults, changes in power and voltage references, changes in system frequency, testing frequency response in sub and super-synchronous ranges, and testing of protection operation. Tests should also be performed under a variety of system strengths, including very weak systems. Other tests may also be required. The validation report is required along with any model updates that result from the more rigorous validation tests.

<sup>9</sup> Models with timesteps less than 10  $\mu$ s may be acceptable in situations where a small timestep does not significantly increase the runtime of the total simulation

<sup>10</sup> Depending on specific application and whether E-Tran Plus for PSCAD is allowed to be used to overcome the limitation, this requirement may be waived.

4b	Generator step-up transformer(s) included, with impedance between 5 and 10% on generator base, and matches SLD. <sup>11</sup>		
4c	Lumped collector equivalent(s) included, with total charging equal to between 0.5 and 5% of plant rating, and matches SLD. <sup>11</sup>		
4d	Substation transformer(s) included, rated appropriately for plant size, and impedance between 6 and 12% on transformer base, and matches SLD. <sup>11</sup>		
4e	Model can be scaled to represent any number inverters/turbines, either using a scaling transformer or internal scaling.		
4f	All external devices included in the plant (such as STATCOMs) include appropriate models.		
<i>Plant controller verification</i>			
5a	Model includes power plant controller (PPC)		
5b	PPC accepts an external active power setpoint.		
5c	PPC accepts a voltage setpoint.		
5d	PPC has a mechanism to implement a settable voltage droop.		
5e	Overall plant responds to frequency changes by increasing or decreasing its active power as appropriate. This may be accomplished either at an inverter level or via the PPC. <sup>12</sup>		
5f	Model initializes to the setpoints specified in the PPC. If droops or deadbands are utilized, the initial values may differ from the setpoints. <sup>13</sup>		
5g	If external voltage control devices (STATCOM/DVAR, SVC, MSCs) are included in the plant, ensure that the voltage control of these devices is coordinated with the PPC, with no potential for VAR looping or oscillations.		
<i>Basic performance verification<sup>14</sup></i>			
6a	Instantaneous voltage and current waveforms have minimal distortion, and no oscillations are observed.		

<sup>11</sup> Impedance range is for sanity checking only. Impedances outside this range may be allowed.

<sup>12</sup> Non-compliance with this item may not require model revision as frequency response may not be required in PSCAD models by some utilities. In this case, a description of the under/over frequency response capabilities of the actual equipment should be provided by the manufacturer.

<sup>13</sup> If voltage control with droop is implemented, it is preferred that the PPC model requests an initial Q value to match the voltage setpoint. If no initial Q is requested, the voltage setpoint can be biased by the initial Q before it is sent to the PPC. If a non-zero deadband is included in the voltage controller, the deadband can also be considered in the voltage setpoint sent to the PPC.

<sup>14</sup> Performance testing is recommended with a POI level SCR of 2.5 as this is a representative system condition seen during weak system studies. Testing may be performed at higher SCRs if the stable operating SCR of a model is known to be above 2.5.

6b	Model is able to ride-through and recover from a temporary (no line outage or drop in SCR), 6-cycle, zero-impedance, three-phase fault at the high side of the station transformer, with a POI level SCR of 2.5.		
6c	Model responds to a step change in PPC voltage setpoint, reaching 90% of the new value between 1 and 10 seconds in a test system with POI level SCR of 2.5. (Various systems may have specific speed requirements, which should be met)		
6d	Model responds to a step change in PPC active power setpoint, reaching 90% of the new value between 1 and 10 seconds in a test system with POI level SCR of 2.5. <sup>15</sup>		
<i>Basic protection verification</i> <sup>16</sup>			
7a	Protection settings are implemented. These could be available as inputs in the model, or hard-coded in the black-boxed controls. <sup>17</sup>		
7b	Option to disable protection models is present. <sup>18</sup>		
7c	Model trips or blocks when terminal voltage rises above 1.3 pu for 1.5 second. <sup>19</sup>		
7d	Model trips or blocks when terminal voltage falls below 0.2 pu for 1.5 second. <sup>19</sup>		
7e	Model clearly displays trip / diagnostic signals indicating the status of all pertinent protection elements		
<i>Documentation</i>			
8a	Model documentation states compliance with "PSCAD Model Requirements Rev. 9 Rev. 9" <sup>20</sup> , or is supplied with a completed PSCAD Model Requirements Supplier Checklist.		
8b	Model documentation includes instructions for setup and running of the model, including the recommended range of simulation timesteps. Documentation should give a clear description of trip / operation code signals produced by model.		

<sup>15</sup> Different response time criteria may apply depending on specific interconnection region.

<sup>16</sup> There are many protection functions which should be modelled, per footnote 1, and these basic tests will not be proof that these are modelled.

<sup>17</sup> If settings are not visible in model or documentation, verification that protection settings are implemented in the PSCAD model should be received from the manufacturer.

<sup>18</sup> Non-compliance may not require model revision as many studies do not require testing with protection settings disabled.

<sup>19</sup> Non-compliance with this item should result in verification of protection settings implementation from the manufacturer, as some models may have capabilities beyond what is listed here.

<sup>20</sup> Non-compliance may be waived in systems which do not require compliance with the model requirements document.



---

## Attachment #2: PSCAD Model Requirements Supplier Checklist

*Electranix makes no representations or warranties of any kind concerning this document, whether express, implied, statutory, or other. This includes, without limitation, warranties of title, merchantability, fitness for a particular purpose, non-infringement, absence of latent or other defects, accuracy, or the presence or absence of errors, whether or not known or discoverable. Electranix will not be held liable for any direct, special, indirect, incidental, consequential, punitive, exemplary, or other losses, costs, expenses, or damages arising out of use of this document or any material herein, even if Electranix has been advised of the possibility of such losses, costs, expenses, or damages.*

Copyright PSCAD Model Requirements Supplier Checklist © 2020 by Electranix Corporation. Please contact [info@electranix.com](mailto:info@electranix.com) for information regarding use or modification of this document.

## Purpose

This document is a model requirements checklist which should be completed by the supplier of the model and submitted alongside each PSCAD model. This document accompanies the “PSCAD Model Requirements Rev. 9” document above (PMR), which should be used for further reference to describe the requirements associated with each point. Generic testing of the model may be done using “Attachment #1: PSCAD Model Test Checklist”, which may be used as a reference.

Model supplier must review every item in the checklist and indicate compliance for each item. If the supplied model does not meet any of the requirements an explanation of the deficiency should be provided in the comments column.

<i>Model Submission Summary (to be completed by model supplier)</i>	
Submission date:	
Project Name:	
Primary contact information for model related questions:	
Secondary contact information for model related questions:	
Manufacturer:	
Equipment type: (eg. PV or Wind)	
Equipment version:	
Documentation file(s):	
Model Files supplied:	



**Recommended PSCAD Model Requirements Rev. 9  
May 8, 2020**

Model Requirements Checklist				Model Complies? (Yes/No)	Comments
1	<i>Model Accuracy Features</i>				
1.1	Power electronic controls are modelled by interfacing with actual firmware code from the inverter (“real code” model), or includes detailed validation report.	A, B			
1.2	Operating modes which require system specific adjustment are accessible.	B			
1.3	Plant level controller is included. <sup>21</sup>	B			
1.4	Model is capable of controlling frequency <sup>22</sup>	B			
1.5	Includes pertinent electrical and mechanical features, such as gearboxes, pitch controllers, or other features which impact the plant performance in the simulation period. <sup>23</sup>	C			
1.6	All protections which could impact ride-through performance are modelled in detail.	D			
1.7	Model is configured for the specific site being evaluated, as far as they are known.	E			
2	<i>Model and Project Documentation</i>				
2.1	Model includes documentation.	J			
2.2	Documentation includes instruction for setup and running the model.	J			

<sup>21</sup> If the plant is part of a multi-plant control scheme, a description of the overall scheme should be provided, and corresponding PPC models should be configured to control multiple plants accordingly.

<sup>22</sup> Frequency control model requirements may vary by region. Example response time may be less than 10 seconds.

<sup>23</sup> Simulation period may vary depending on the model use, but 10 seconds of simulation following an event such as a fault is a typical period.

This work is licensed under the Creative Commons Attribution 4.0 International License. To view a copy of this license, visit <http://creativecommons.org/licenses/by/4.0/> or send a letter to Creative Commons, PO Box 1866, Mountain View, CA 94042, USA.



**Recommended PSCAD Model Requirements Rev. 9  
May 8, 2020**

2.3	Model is supplied with a sample test case including site specific plant representation.	J	
2.4	Plant single line diagram is provided, and aligns with model	J	
2.5	Model documentation provides a clear way to identify site-specific settings and equipment configuration.	K	
<b>3</b>	<b><i>Model Usability Features</i></b>		
3.01	Control or hardware options are accessible to the user as applicable.	F	
3.02	Diagnostic flags are visible to the user.	F	
3.03	Model uses a timestep greater than 10 μs.	G	
3.04	Model allows a range of simulation timesteps (ie. not restricted to a single timestep).	H	
3.05	Protection model may be disabled for troubleshooting	I	
3.06	Model accepts external reference variables for active and reactive power and voltage setpoint, and these may be changed dynamically during the simulation.	L	
3.07	Model is capable of initializing itself.	M	
3.08	Active power capacity is scalable.	N	
3.09	Active power is dispatchable.	O	
3.10	Model reaches setpoint P, Q, and V in 5 seconds or less	P	
3.11	Model compatible with Intel FORTRAN version 12 and higher.	Q	
3.12	Model compiles using PSCAD version 4.5.3 or higher.	R	
3.13	Model supports multiple instances of its own definition in a single PSCAD case.	S	
3.14	Model supports PSCAD “snapshot” feature.	T	

This work is licensed under the Creative Commons Attribution 4.0 International License. To view a copy of this license, visit <http://creativecommons.org/licenses/by/4.0/> or send a letter to Creative Commons, PO Box 1866, Mountain View, CA 94042, USA.

**Recommended PSCAD Model Requirements Rev. 9  
 May 8, 2020**



3.15	Model supports the PSCAD “multiple run” feature.	U	
3.16	Model does not use PSCAD global variables.	V	
3.17	Model does not use PSCAD layer functionality	W	

---

This work is licensed under the Creative Commons Attribution 4.0 International License. To view a copy of this license, visit <http://creativecommons.org/licenses/by/4.0/> or send a letter to Creative Commons, PO Box 1866, Mountain View, CA 94042, USA.

## DETAILED INSTRUCTIONS FOR COMMUNITY OUTREACH PLAN

- The Community Outreach Plan should be as current and explanatory as possible.
  - The Community Outreach Plan information must be included in the information Proposers selected to the Final Award Group make available on their website when the website is posted publicly.
- Proposers selected to the Final Award Group must develop a public Project website, which shall include all the information on the Community Outreach Plan table for their Project.
- Proposers must develop Project presentations that include all the information on the Community Outreach Plan table (sample template provided).
- Due to the uncertainty of the duration of the COVID-19 pandemic, all Proposers are required to plan for both in-person and virtual community meetings. As we near the dates that community meetings are scheduled, in the interest of public health and safety, the conditions at the time will determine if in-person meetings or virtual meetings will be required.
  - Virtual community meetings can either be community televised, or online, but must incorporate technology that allows for live engagement and interaction between the Proposer and community participants.
- Proposers must communicate important information about the Project with stakeholders in advance of community meetings.
- Proposers must perform media outreach (earned media) and advertising (paid media) to raise community awareness of any public meeting. Media advisories (sample attached) must be issued to the following media and organizations a minimum of 30 days prior to a public meeting. Media advisories do not need to be reviewed and approved by Hawaiian Electric, but must be shared with Hawaiian Electric for awareness.
  - For Oahu Projects
    - Star Advertiser
    - Civil Beat
    - Hawaii News Now
    - KHON2 News
    - KITV4 News
    - Neighborhood Boards
  - For Maui Projects
    - Maui News
    - Maui Now
    - Civil Beat
    - Hawaii News Now
    - KHON2 News
    - KITV4 News
  - For Hawaii Island Projects
    - Hawaii Tribune Herald
    - West Hawaii Today
    - Civil Beat
    - Hawaii News Now
    - KHON2 News
    - KITV4 News
- Advertisements must be placed in area community publications.
  - Guidance from the Company can be provided upon request
  - Information in the ads must be consistent with the media advisory
- Public comments in support and in opposition to the proposed Project must be compiled and filed verbatim with the Public Utilities Commission.
- Proposers must work with and inform neighboring communities and stakeholders to provide community members timely information during ALL phases of the project, which must include,

but not be limited to the Power Purchase Agreement negotiation period, the permitting process periods, and throughout construction.

- Should any COVID-19 related events interfere with the Proposer's ability to perform the listed actions, Proposer should inform the Company immediately of such effects for Company's consideration and guidance, and possible proposal of alternate actions.

**CONTACT:**      **NAME, 808.XXX.XXXX**      **FOR IMMEDIATE RELEASE**  
Email address      Date

### Media Advisory: Title

Project description to be drafted by developer. Description must include the location of proposed project and supporting background information.

**Date:**      TBD

**Time:**      TBD

**Location:**      TBD

**Purpose:**      To share information about a **TYPE (e. g. CBRE solar, etc.)** renewable energy project proposed to be developed in **COMMUNITY** near **AREA REFERENCE** and to solicit public comments to be filed with the Public Utilities Commission.

**Contact:**      For more information, call **808.XXX.XXXX** or visit **(website/social media)**

###

**Project Name**

**Proposer Name**



# Project Benefits

- Details

# Community Benefits

- Details

# Proposed Facility Location in/near what City/Area

- Map
- Dimensions of proposed project
- Include all project components

# Project Description

- Details

# Site Layout Plan

- Project Layout
- Project Visual Simulations
  - Multiple public vantage points

# Interconnection Route

- Map

# Required Government Permits and Approvals

- Preliminary Schedule
- Opportunities for public comment

# Environmental Impacts

- Preliminary environmental assessment of the site (including any pre-existing environmental conditions)



## Cultural Impacts

- Identify any cultural, historic or natural resources that will be impacted by the project
- Describe the potential impacts on these resources
- Identify measures to mitigate such impacts.

# Where to Find More Information

- Project website
- Proposer email and contact information

# How to Provide Comments

**DRAFT**  
**REQUEST FOR PROPOSALS**  
**FOR**  
**COMMUNITY-BASED RENEWABLE ENERGY TRANCHE 1**  
**ISLAND OF HAWAI‘I**

DECEMBER 1, 2020

Docket No. 2015-0389

*Appendix C – Code of Conduct Procedures Manual*

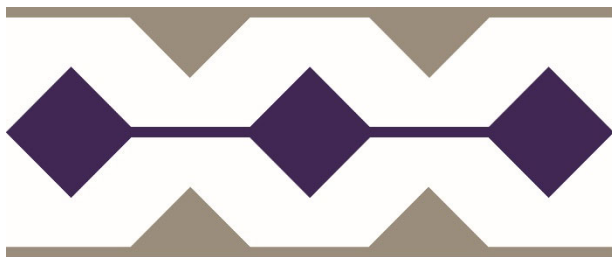

**Hawai‘i  
Electric  
Light**

## I. INTRODUCTION

The Framework for Competitive Bidding ("Framework") adopted on December 8, 2006, by the Public Utilities Commission of the State of Hawaii (the "Commission") pursuant to Decision and Order No. 23121 (Docket No. 03-0372, Instituting a Proceeding to Investigate Competitive Bidding for New Generating Capacity in Hawaii) requires that the utility develop and follow a Code of Conduct whenever a utility or its affiliate seeks to advance an energy generation resource proposal in response to a request for proposals ("RFP") issued by the Company. Section III.A.4 of the Framework required the utility to submit to the Commission for review and approval (subject to modification if necessary) a code of conduct prior to the commencement of any competitive bid process under the Framework. The proposed *Code of Conduct Pertaining to the Implementation of a Competitive Bidding Process for Community-Based Renewable Energy* (the "Code of Conduct") requires the Companies to also propose this *Code of Conduct Procedures Manual* (the "Procedures Manual") to implement the requirements of the Framework and the Code of Conduct.

This Procedures Manual has been developed to outline the procedures to be followed and the policies that have been developed surrounding the implementation of the Companies' competitive bidding process for system resources. This Code of Conduct Procedures Manual has been developed for the Companies' Community-Based Renewable Energy RFPs and in accordance with the requirements of Section IV.H.9.a(iii) of the Framework and outlines requirements (1), (3) and (4) of such section, namely: (1) the protocols for communicating with Proposers, the Company Self-Build team, and others; (3) the documentation forms, including logs for any communications with proposers; and (4) other information consistent with the requirements of the solicitation process. Requirement (2) of the section, the evaluation process in detail and the methodologies for undertaking the evaluation process for the RFP are described in detail in the Community-Based Renewable Energy RFP. The bid evaluation process and methodology will consider both price/system impacts and non-price criteria in accordance with Section IV.E of the Framework and Tariff Rule 19.

The procedures and policies set forth herein have been designed to ensure that the procurement process is undertaken in a fair and equitable manner and that each Proposer is afforded an equal opportunity to participate and compete within the RFP requirements.

This Procedures Manual is intended to be followed by Company personnel in connection with implementing the Companies' solicitation process and to manage communications between Company personnel and consultants participating in the RFP processes covered by the Framework. Necessary additions, deletions, and/or changes depending on the circumstances surrounding the RFP and directions from the IO may be required.

## **II. DEFINITIONS**

- Affiliate – Any person or entity that possesses an “affiliated interest” in a utility as defined by section 269-19.5, Hawaii Revised Statutes (“HRS”), including a utility’s parent holding company but excluding a utility’s subsidiary or parent which is also a regulated utility.
- Affiliate Team – Employees and consultants of an Affiliate of the Company who prepare a proposal to be submitted to the Company in response to a Company RFP.
- ATRs – The Affiliate Transaction Requirements, issued by the Commission, applicable to the Companies and Affiliates, attached as Exhibit B to Order No. 36112 issued on January 24, 2019 in Docket No. 2018-0065.
- Code of Conduct – The *Code of Conduct Pertaining to the Implementation of a Competitive Bidding Process for Community-Based Renewable Energy* developed by Hawaiian Electric Company, Inc., Maui Electric Company, Limited and Hawaii Electric Light Company, Inc. (each, a “Company” and collectively, the “Companies”) to ensure the fairness and integrity of the competitive bidding process, in particular where the host utility or its affiliate seeks to advance its own system resource proposal in response to an RFP. The Code of Conduct follows the requirements described in Section IV.H.9.c of the Framework.

- Code of Conduct Acknowledgement – The Competitive Bidding Code of Conduct Acknowledgement of Receipt form acknowledging review of, and agreeing to abide by, the Code of Conduct and this Procedures Manual.
- Communications Log – A written record to note activities and/or information shared between the Company RFP Team or Company Self-Build Team with Shared Resources or Unassigned Company Resources, accessed via the RFP Communication Tool Kit SharePoint Site.
- Companies' Executive in Charge – The Companies' executive responsible for ensuring compliance with this Code of Conduct and serving as the point of contact for the Independent Observer for reporting any violations by the Companies' of the Code of Conduct. The Companies' Corporate Compliance Officer shall remain responsible for the Companies' independent corporate code of conduct and may support compliance matters and questions arising with employees, agents and other representatives of the Companies, e.g., conflicts of interest, with respect to this Code of Conduct.
- Company RFP Team – The Company personnel and outside consultants responsible for the development of the Company's RFPs conducted under the Framework and the evaluation of bids submitted in response to these RFPs. Subject to the transfer rules specified herein, the Company RFP Team will have fixed team members who will not have any involvement with the Company Self-Build Team for the subject RFP.
- Company Self-Build Team – The Company personnel and outside consultants responsible for the development of the Company's self-build responses to the RFP. Subject to the transfer rules specified herein, the Company Self-Build Team will have fixed team members who will not have any involvement with the Company RFP Team for the subject RFP.
- Confidential Information – Any non-public information developed and provided by the Company (i.e., proprietary system information, etc.) or Proposers during the RFP process (such non-public information may include, for example, the identity of competing Proposers, and their technical, trade or financial information). This term includes any material non-public information regarding the RFP process developed for and used during the competitive bidding solicitation process, such as the evaluation process or criteria. Confidential Information does not include

public information, such as information in the Company's public filings with the Commission.

- Director of Renewable Acquisition – The supervisor of the Division that will oversee the Company's competitive bidding process.
- Eligible Proposer – A Proposer who has met the minimum requirements and threshold requirements in the RFP necessary to remain eligible to compete in the process.
- Energy Contract Manager – The staff position(s) within the Company's Renewable Acquisition Division responsible for managing the Company RFP Team(s). The Energy Contract Manager shall be a member of the Company RFP Team he/she manages.
- Framework – The Framework for Competitive Bidding contained in Decision & Order No. 23121 issued by Commission on December 8, 2006, to establish rules for competitive bidding in response to a request for proposals when a utility seeks to acquire new generation resources.
- Independent Observer ("IO") – The neutral person or entity appointed by either the Commission or utility to monitor the utility's competitive bidding process, and to advise the utility and Commission on matters arising out of the competitive bidding process, as described in Part III.C of the Framework.
- Manager of Energy Procurement - The supervisor of the department within the Company's Renewable Acquisition Division responsible for directing the resources responsible for the implementation of the competitive bidding process pursuant to the Framework. The Manager of Energy Procurement will report to the Director of Renewable Acquisition on the status of the competitive bidding process and shall be a member of the Company RFP Team.
- Non-Price Evaluation Team – Employees and consultants of the Company who evaluate the Proposal non-price related criteria as set forth in these RFPs. Non-Price Evaluation Team members will not include any Shared Resources and will be solely made up of Company RFP Team Members.
- Non-Wires Alternative - An electricity grid project that uses non-traditional transmission and distribution (T&D) solutions, such as distributed generation (DG), energy storage, energy efficiency (EE), demand response (DR) and grid software and controls, to defer or avoid the need for conventional transmission and/or



distribution infrastructure investments.

- Price Evaluation Team – Employees and consultants of the Company who evaluate the Proposal price related criteria set forth in these RFPs. Price Evaluation Team members will not include any Shared Resources and will be solely made up of Company RFP Team Members.
- Proposer – Entity who submits or plans to submit a proposal in response to a Company-issued RFP. An Affiliate of the Company or a Company Self-Build Team participating in the RFP and submitting a proposal shall be considered a Proposer.
- RFP – A written request for proposals issued by one of the Companies to publicly solicit bids to supply future system resources to the Company pursuant to the competitive bidding process established in the Framework.
- Roster – A consolidated list of members that comprise the Company RFP Team, Company Self-Build Team, Shared Resources and Unassigned Company Resources located in the RFP Communication Tool Kit SharePoint Site. Company employee names and titles and consultants in their designated role will be identified.
- Shared Resource – Company employees and consultants who, because of the scarcity of their expertise within the Company, are designated and authorized to provide information or input to both the Company RFP Team and the Company Self-Build Team (but not any Affiliate Team) and is not a resource dedicated to either team. For example, Shared Resources may include an environmental attorney and members of the Company’s Risk Management Department.
- Unassigned Company Resource – Company employees unassigned to an essential team that may be called upon by the Company RFP Team and/or the Company Self-Build Team (but not any Affiliate Team) to assist in meeting unforeseen tasks for the RFP or the self-build proposal. For example, the Company RFP Team may be unable to evaluate an unforeseen technical specification included in a bid. In that event, the Company RFP team would need to request assistance from a Company employee or a consultant that is not already assigned to an essential team and possesses the specific expertise. Such personnel are intended to assist the requesting team only in an ad hoc manner, limited in scope and purpose to the particular task required.

### **III. STATEMENT OF OBJECTIVES**

On April 9, 2020, the Commission issued Order 37070, commencing Phase 2 of the Community-Based Renewable Energy Program ("Phase 2"). Phase 2 requires the Companies to implement competitive bidding to procure CBRE projects on all islands served by the Companies. These procurements will be concurrent and overlapping. Subsequent phases of CBRE may require further procurements through competitive bidding. Accordingly, under the Framework and the Code of Conduct, for each of the competitive procurements under the program, the Companies will undertake a detailed multi-stage review and evaluation process whereby eligible proposals will be selected based upon their ability to most cost-effectively and reliably satisfy the CBRE program requirements.

Given that multiple RFPs for CBRE, including and in addition to other RFPs currently being administered by the Companies, will be active at the same time, and because the Companies must work expeditiously, in order to consistently ensure the competitive benefits of the procurement process while continuing to provide equitable and fair consideration for all proposals, the Companies will endeavor to create, designate and maintain the Roster at all times for quicker and more decisive implementation across all active RFPs. Subject to the transfer rules specified herein, the Roster will be maintained for the durations of the RFPs. The Companies also intend that the evaluation process will be well-documented so that the results of the evaluation can be fully reviewed by an IO to confirm that all proposals were treated in a fair and consistent manner.

The Code of Conduct and this Procedures Manual address (1) communication requirements and procedures associated with the relationship between utility employees (Company RFP Team, Company Self-Build Team, Shared Resources and Unassigned Company Resources); (2) communication requirements and procedures associated with the relationship between the Company RFP Team, the Company Self-Build Team and Proposers; and (3) communication requirements associated with the relationship between Company management and the Company RFP Team.

The Code of Conduct and this Procedures Manual also include procedures for the sharing of resources, where appropriate, by the Company RFP Team and the Company

Self-Build Team for the purposes of completing their efforts to effectively evaluate an RFP or to submit a bid in response to an RFP. The small size of the Companies and limitation of resources will require specialized services, information exchange and sharing of resources in certain limited circumstances. Company personnel and consultants identified as "Shared Resources" shall be designated by the Companies for this specific purpose.

#### **IV. ORGANIZATION AND COMMUNICATION RESPONSIBILITIES**

This section outlines the RFP organizational structure for the development of the RFP and the Company self-build options and the organization's responsibilities to ensure that communications between Company personnel and consultants working on their respective RFPs or self-build projects are conducted in a fair, consistent, and equitable basis so that the Company Self-Build Team does not enjoy any unfair advantage over other Proposers responding to an RFP.

##### **A. Organization**

The Companies shall identify and maintain two separate teams to facilitate the independence and objectivity of the Company resources working on an RFP and ensure an arms-length relationship with the resources working on the Company's self-build project to avoid any real or perceived inequity in an RFP process. The two essential teams shall be the "Company RFP Team" and the "Company Self-Build Team."

Other limited Company resources, such as select staff from various functional areas of the Company that are in short supply and thus cannot be dedicated solely to either team, may be designated as "Shared Resources" to perform services for the Company RFP Team and Company Self-Build Team. Shared Resource employees are allowed to carry on with both their RFP (for either the Company RFP Team and/or the Company Self-Build Team) and regular functions throughout the resource planning process (including the development of any Company Parallel or Contingency Plan as defined in the Framework), which may require communications with or services performed for the Company Self-Build Team. Shared Resource employees, however, will not participate in the evaluation and selection process of proposals submitted in response to

an RFP. Rules for communications between Shared Resources and the essential teams are specified below.

Company employees unassigned to an RFP may be called upon by the Company RFP Team, Company Self-Build Team, or both for help to meet unforeseen tasks. After completing the Code of Conduct training, these "Unassigned Company Resources" are eligible to assist on an ad hoc basis with the requirement that all communications as an Unassigned Company Resource must be memorialized and logged in the same manner as communications with Shared Resources on the Communication Log. If an Unassigned Company Resource is called upon repeatedly for a substantial amount of assistance by a particular team, the employee should be assigned to such team or evaluated for designation as a shared resource.

**B. Essential Teams**

1. Company RFP Team. The Company RFP Team, tasked with preparing the RFP and evaluating the responses and bids in response to the RFP, will consist primarily of Director/Manager-level and other experienced employees together with possible outside consultants, with backgrounds in a number of disciplines necessary to conduct a thorough evaluation of each proposal. The Company RFP Team will be comprised of a Price Evaluation Team and a Non-Price Evaluation Team and will be prepared to evaluate proposals on the basis of their price and non-price aspects pertaining to their level of expertise. Members of the Company RFP Team will include professionals with experience in the following areas of expertise: engineering, siting/land use, environmental, transmission planning, fuel procurement, legal, financial planning, system operations, integrated resource planning, generation planning, production cost analysis, and others as needed.

The Price Evaluation Team and the Non-Price Evaluation Team will conduct their sections of the bid evaluation process separately and will not share the results of their evaluation with members of the other sub-team. Each team will submit their evaluation results to an oversight team, which will be responsible for compiling the results of the evaluations and selecting the Priority List.

The Energy Contract Manager will be responsible for directing the evaluation efforts of the Company RFP Team when the proposals are received. The Energy Contract Manager will be responsible for maintaining the documentation underlying the evaluation of each proposal as well as all communications with Proposers.

2. The Company Self-Build Team. The Company Self-Build Team, tasked with preparing any Company proposal to be submitted by the Company in response to a Company RFP, will consist primarily of Company employees, along with possible outside consultants with backgrounds in a number of disciplines necessary to complete a competitive proposal in response to a Company RFP. The members of the team will include professionals with experience in the following areas of expertise: engineering, siting/land use, environmental, transmission planning, fuel procurement, legal, financial planning, system operations, integrated resource planning, generation planning, production cost analysis, and others as needed.

3. Affiliate Team. Any Affiliate Team will be comprised solely of employees and consultants of the Affiliate and no Company employee or consultant shall serve as a member of an Affiliate Team; provided, however, that a consultant may perform services for an Affiliate and the Company so long as appropriate "walls" are established satisfactory to the Company that ensures that employees of the consultant working for the Affiliate Team do not also perform work for the Company nor communicate with employees of the consultant performing work for the Company, and vice versa. The Company will inform consultants providing services for the Company RFP Team of these separation requirements, and will seek confirmation in writing from any consultant performing services for an Affiliate and the Company that such separation requirements will be met. Affiliate Teams will be considered and treated as separate independent third-party Proposers for all purposes within any RFP and shall have no access to, interaction or communications with Shared Resources or Unassigned Company Resources for the purpose of completing a proposal in response to any RFP. Affiliate Teams shall also be subject at all times to the terms, conditions and restrictions specified in the Company's ATRs.

4. Transfers between Teams. As members of both the Company RFP

Team and the Company Self-Build Team are intended to be fixed, transfers between teams should not be permitted. However, there will be instances where a member of a particular team (whether Company RFP or Company Self-Build) transfers to a position in which he/she may be requested, as part of his/her new job responsibilities, to participate as a member of the other team. Such employee shall not be permitted to transfer from one team to the other during the pendency of any particular RFP (or stage or phase of a particular RFP). After completion of the RFP (or stage or phase of a particular RFP) under which the employee recently participated, the employee may transfer to the other team under the following conditions: (a) the employee is prohibited from disclosing any Confidential Information known to such employee as a result of being a member of his/her former team with members of the new team he/she is joining; and (b) for a period of one (1) year, such employee shall not participate or be involved in the evaluation of any subsequent stage(s) or phase(s) of a prior RFP which such employee participated in with his/her former team.

Transfers of employees between the Company and any Affiliate and their subsequent work on RFPs shall be subject to the terms, conditions and restrictions specified in the ATRs.

## **C. Communications Protocols**

### **1. Overview and General Requirements.**

The Company has developed policies and procedures governing communication between the Company RFP Team, the Company Self-Build Team, Shared Resources, the Proposers, the IO, and with the Commission regarding RFP design and bid evaluation. Bid information and evaluation data and information shall not be communicated between members of the Company RFP Team, outside parties and other employees within the Companies except to those with a business need to know.

To ensure that the competitive bidding process is fair and unbiased, that all Proposers have access to the same information so that no Proposer has an unfair advantage, and that any Company self-build and/or Affiliate proposals do not have any unfair competitive advantage over third-party bids, the Companies shall follow the Code

of Conduct whenever the utility or its Affiliate is seeking to advance a resource proposal as provided in Section IV.H.9.b of the Framework.

Each employee or consultant on the Company RFP Team, Company Self-Build Team and Shared Resources shall read, acknowledge and sign the Code of Conduct Acknowledgement. Unassigned Company Resources who are called upon by the Company RFP Team or Company Self-Build Team for help to meet unforeseen tasks shall also read, acknowledge and sign the Code of Conduct Acknowledgement.

The Company issuing the RFP will establish a shared drive on its corporate computer network designed to maintain the bid evaluation documentation and other information associated with the bidding process. Only Company RFP Team members will have access to all the files on the shared drive.

In cases where staffing and resources are limited or constrained, the Company may identify Shared Resources or those employees eligible to provide information or serve as a resource to both the Company RFP Team and the Company Self-Build Team. Specific rules to log communications with the Company RFP Team or the Company Self-Build Team are described below.

Shared Resources will not have access to the Company's shared drive established for the RFP process which will include the documentation of the bid evaluation results.

Team members should clearly mark all e-mails, documents, or other communications that contain Confidential Information and make clear which team should not receive it with the following header or a substantially similar message: "This communication contains self-build information that must be kept confidential. DO NOT copy, forward, or discuss the contents with Company RFP Team members" OR "This communication contains Company RFP Team information that must be kept confidential. DO NOT copy, forward, or discuss the contents with Company Self-Build Team members."

## **2. Communications Between the Company RFP Team and**

**Proposers, including the Company Self-Build Team and any Affiliate Team.**

During the RFP process, the Energy Contract Manager shall serve as the primary contact person for all RFP communications with Proposers. This is important from the standpoint of maintaining consistency and confidentiality of information between Proposers and the Company. For documentation and oversight purposes, all communications from Proposers must be submitted to an established website link provided by the Company (the "Company RFP website"). The IO will monitor all communications through the Company RFP website. To ensure fair and equal access to information, any Company Self-Build Team and/or Affiliate Team shall be considered a Proposer for communication purposes and any request for information from the Company Self-Build Team or Affiliate Team to the Company RFP Team shall be through the Company RFP website.

Subject to confidentiality obligations, it is the objective of the Code of Conduct that all Proposers, including the Company Self-Build Team and any Affiliate Team, receive access to information released by the Company RFP Team, whether in response to a question from a Proposer or not, at the same time.

The communications process for addressing questions and requests for information from Proposers, and for the Company RFP Team to provide information to Proposers, is provided below:

- a. Other than during Company sponsored conferences, Proposers must submit all questions to the Company RFP website or the designated RFP email address (if the Company RFP website has not been opened yet for the RFP).
- b. Questions will be reviewed and responses will be coordinated with the appropriate functional area within the Company for a response. Every reasonable effort will be made to provide responses in a timely manner.



- c. All responses, including the classification of such response, i.e., whether non-confidential or confidential as described below, will be provided to the IO for monitoring purposes via email or the PowerAdvocate messaging system. The IO may choose to comment on any response at its discretion.
  
- d. Depending on the questions received, responses may involve Confidential Information of the Company and/or Proposers. Release of any Company Confidential Information must be approved in advance by the Company executive authorized to release the Confidential Information. Any release of Company Confidential Information shall be accompanied by appropriate confidentiality and non-disclosure agreements, protective orders or other means required to maintain the confidentiality of the Company Confidential Information while still permitting its disclosure under circumstances deemed appropriate by the responsible Company executive. Other non-Company Confidential Information will not be shared without the prior written consent of the owner of such Confidential Information and the execution of appropriate confidentiality and non-disclosure agreements by all recipients of such Confidential Information. Responses will be categorized as follows:
  - i. Non-Confidential Responses: Questions and responses will either be posted directly on the Company RFP website (process-related questions or simple, non-substantive information) or a description of the information that can be made available will be posted and Proposers will be instructed to submit a request to the Company via the Company RFP website to receive a copy.
  
  - ii. Confidential Responses: Questions and a description or notice of a Confidential Information response will be posted on

the Company RFP website and Proposers will be instructed to submit a request to the Company via the Company RFP website to receive instructions on how to access the Confidential Information. The Confidential Information will only be provided to the requestor after receipt of an executed confidentiality and non-disclosure agreement. Only those who have qualified to submit a bid (i.e., Eligible Proposers) and have executed a confidentiality and non-disclosure agreement will be considered for receipt of Confidential Information.

iii. Process for Distribution of Confidential Information: Confidential Information provided in response to questions from proposers may be made available only to parties as indicated above via the following:

A. Confidential Information that is approved for exchanging on a secured access site: (1) Confidential Information may be made available on a secured website with an individual password provided to each approved Proposer; and (2) Confidential Information in documents may be transmitted to approved recipients through the Company's secure email system.

B. Confidential Information that can be made available for inspection only, but cannot be copied: There may be some types of Confidential Information that the Company may consider making available for inspection only with no copies allowed. This type of Confidential Information will be made available on Company premises for inspection only. Proposers will be advised via the Company RFP website to make arrangements with Company staff to view the Confidential Information.

C. Confidential Information that may not be released:

In the event that Proposers submit questions that require responses that the Company feels are not appropriate to provide for reasons which may include, but not be limited to, safety, security, protection of trade secrets or intellectual property rights, Proposers will be advised as such via the Company RFP website.

- e. Prior to and during the RFP, and outside of the Company RFP website protocol, developers may direct questions to the Company prior to submitting a Proposal to discuss specific questions regarding their specific Proposal. Questions shall be directed to the Company Contact for Proposals listed in the particular applicable RFP. Questions and responses that do not contain Confidential Information and which are deemed relevant to all Proposers will be published without identifying information via the Company RFP website.
- f. Once bids are received, the Company may submit information requests to Proposers to clarify their proposals or request additional information. All contacts with Proposers will be through the Company RFP website. All contacts and information exchanged will be under the oversight of the IO.
- g. A single exception to the communication process outlined above shall be instituted for the purpose of facilitating the verification of proposed project models and documentation required to perform the IRS. For this limited scope, the Company's Manager of Interconnection Services will serve as the primary contact person for all such interconnection communications with the Proposers on the Priority List, provided that all necessary confidentiality and

non-disclosure agreements are in place. The Manager of Interconnection Services and personnel in the Interconnection Services Department shall be members of the Company RFP Team. Interconnection communications will be limited to a Proposer's bid and no more information other than as necessary to facilitate such communications will be permitted. Discussion of locations of proposed projects shall be limited to that necessary only to determine the interconnection requirements of such project. The IO shall have the right to monitor all such communications in his/her discretion.

**3. Communications Between the Companies and the Commission.**

The Company's Regulatory Affairs staff will be responsible for initiating communication with the Commission regarding the RFP or the Companies' evaluation process. Regular updates may be provided to the Commission regarding the RFP process if requested.

**4. Communications Between the Company RFP Team and the IO.**

Communications between the Company RFP Team and the IO will be required for many aspects of the evaluation process. The IO is also required to maintain confidentiality of any Confidential Information. The IO will coordinate all activities through the Energy Contract Manager. The IO will be invited to participate in any meetings or discussions between the Company RFP Team and the Proposers and other communications as noted above. Sufficient notice will be provided whenever possible and teleconference and/or web conference alternatives may be utilized.

**5. Communications Between the Company RFP Team and the Company Self-Build Team or any Affiliate Team.**

Any communication between the Company RFP Team and the Company Self-Build Team or any Affiliate Team with respect to the RFP shall be handled no differently than with Proposers and other outside parties. Accordingly, the Company Self-Build Team or any Affiliate Team will be required to submit any questions or information requests to the Company RFP Team via the Company RFP website and all responses will be provided in the same manner as to other Proposers. Accordingly, as stated in Section 2 above, responses will be provided to the IO for monitoring purposes via email or the PowerAdvocate messaging system. Members of the Company RFP Team are prohibited from providing any input into the development of the self-build option by the Company or an Affiliate. Company RFP Team members are prohibited from sharing any Confidential Information (i.e., detailed evaluation criteria, other proposals, etc.) with any Company Self-Build or Affiliate Teams except in accordance with the procedures in the Code of Conduct, this Manual or the RFP.

Company RFP Team members and Company Self-Build Team members may continue to work with each other on projects not related to the RFP. Further, members of each respective team do not have to be physically separated from each other, but members of each team must make reasonable efforts to keep all Confidential Information (including electronic data) secure and inaccessible to the other team.

Company RFP Team members and Affiliate Team members may continue to work with each other on matters not related to the RFP as permitted under the ATRs.

## **6. Communications among the Company RFP Team, the Company Self-Build Team and Shared Resources.**

Shared Resources may provide services to the Company RFP Team and the Company Self-Build Team (but not any Affiliate Team). Shared Resources shall be limited as much as possible to instances where Company resources cannot provide a dedicated member to the Company RFP Team and the Company Self-Build Team at the same time and still provide the necessary functions of its area to the Company as a whole. Shared

Resources are expressly prohibited from providing any information developed on behalf of the Company RFP Team to the Company Self-Build Team or any information developed on behalf of the Company Self-Build Team with the Company RFP Team, except through the formal communication process outlined above, i.e., through the Company RFP website.

Additionally, a written record of the time, date and substance of all conversations, data and written material directly or indirectly exchanged with the Company RFP Team or the Company Self-Build Team that pertain to the RFP shall be maintained on the Communications Log. The RFP Communication Tool Kit SharePoint Site will be set up and managed by the Energy Contract Manager to provide an easy to use and understand mechanism to log and memorialize these conversations.

Shared Resources will not have direct access to the Company's shared drive developed for the RFP process which will include documentation of the bid evaluation results.

**7. Communications between the Company RFP Team, the Company Self-Build Team and any Unassigned Company Resource or consultant that is not a Shared Resource.**

There may be times where a Company RFP or Company Self-Build team (but not an Affiliate Team) member may need ancillary or other ministerial or administrative assistance that requires communication and/or assistance from Company personnel who are neither on any team nor considered a Shared Resource. Under those circumstances, such personnel may assist the requesting team member on an ad hoc basis upon the following conditions:

- a. The essential team member making the request must inform the Company personnel that sharing of the requested information or assistance with the other team, be it the Company RFP or Company Self-Build Team, is expressly prohibited under the Code of Conduct.

b. The assisting Company personnel shall complete the Code of Conduct training and sign the Code of Conduct Acknowledgement.

c. The assisting Company personnel shall be directed to the Roster provided by such requesting team member to determine and/or confirm the restrictions on communication with the other team members. The essential team member making the request will ensure the Roster is updated by the Energy Contract Manager to include the assisting Company personnel.

d. A written record of the time, date and substance of all conversations, data and written material directly or indirectly exchanged with the Company RFP Team or the Company Self-Build Team that pertain to the RFP shall be maintained on the Communication Log. The RFP Communication Tool Kit SharePoint Site will be set up and managed by the Energy Contract Manager to provide an easy to use and understand mechanism to log and memorialize these conversations.

e. If assistance from an Unassigned Company Resource becomes more than occasional or more substantive than ancillary, ministerial or administrative services, the Unassigned Company Resource should be considered for inclusion on the team that he/she has been assisting on such basis. Additionally, the Unassigned Company Resource may also be considered for inclusion as a Shared Resource. Members of the Company RFP Team and/or Company Self-Build Team shall consult with the Company executive for resolution.

**8. Communications between the Company RFP Team, the Company Self-Build Team and Company Management.**

The Company RFP Team and the Company Self-Build Team will necessarily require management approval of the RFP and the Company Self-Build Team proposal. Because of the size of the Company, it may be possible that a single employee (at whatever level) (the "Approver") may have approval responsibility for matters affecting the RFP and the Company Self-Build Team proposal. Approvers in this situation must use their best judgment in making decisions reviewing and approving matters for the respective teams. The Code of Conduct must be adhered to in these situations and the Approver must not communicate matters learned from the Company RFP Team with the Company Self-Build Team.

If an Approver feels that he/she cannot manage this potential conflict, the Approver is recommended to consult with his/her immediate supervisor to determine whether such higher authority could be appointed with the task of reviewing and approving matters for a designated team, either the Company RFP Team or the Company Self-Build Team. In matters where a team of employees (including one or more Approvers) is responsible for reviewing and approving matters for the respective teams, approving employees (from whatever level, including executives) with information from reporting personnel beneath them from both the Company RFP Team and the Company Self-Build Team may consider recusing himself/herself from the decision making if such employee cannot objectively make a decision on the matter.

Finally, an Approver may be a member of the Company RFP Team and have a subordinate reporting to him/her that is a member of the Company Self-Build Team (or vice versa). In such situations, because the Code of Conduct prohibits communication between the teams, the Approver must recuse himself/herself from the decision making and request his/her manager to review and approve the matter in his/her place.

In all instances, it is possible that any particular situation above may be addressed and/or resolved by the terms and conditions of the Company's internal code of conduct implemented for all employees and consultants of the Company. As appropriate, an Approver or any other team member, Energy Contract Manager or Company executive in Charge may involve the Company's Corporate Compliance Officer for input and possible



resolution under the Company's internal corporate code of conduct.

**V. WHEN THE CODE OF CONDUCT BECOMES EFFECTIVE**

A. Prior to development of the requirements for any particular RFP, the Code of Conduct for that RFP will be activated. However, if the Company Self-Build Team determines at any time that it will not pursue a self-build option for a particular RFP, the Code of Conduct may be de-activated.

B. Upon the activation of the Code of Conduct, members of the Company RFP Team and the Company Self-Build Team must then conduct activities on the RFP or self-build process in compliance with the Code of Conduct. Once identified and having commenced work, no information may be shared outside the respective team members with respect to the RFP or a self-build option except through the formal communication processes outlined above.

C. Immediately upon assignment to a Company team (RFP or Self-Build), designation as a Shared Resource, or request to assist as an Unassigned Company Resource, each such employee or consultant must review this Manual, and sign the Code of Conduct Acknowledgement.

D. Within the RFP process, after a member has been assigned to a particular Company team (RFP or Self-Build), he or she will not be able to transfer to the other Company team during the pendency of any particular RFP (or stage or phase of a particular RFP). It is the responsibility of each team to fill vacant team positions with employees that have not been previously assigned as a team member for a team until the PPA negotiations have been concluded and the final contracts are executed.

E. Each employee and consultant working on the RFP shall review the Code of Conduct and sign the Code of Conduct Acknowledgement attesting to his/her compliance with the Code of Conduct until the employee is no longer working in the position he/she was in while working on the RFP.

F. The Energy Contract Manager will be responsible for maintaining the Roster and the signed Code of Conduct Acknowledgements. The Company Executive in Charge shall be responsible for ensuring compliance with the Code of Conduct and shall have the written authority and obligation to enforce the Code of Conduct.

## **VI. IMMEDIATE ACTIONS UPON ACTIVATION OF THE CODE OF CONDUCT**

The following items are required to be completed as soon as possible after activation of the Code of Conduct, but no later than the designated events specified for each item below.

A. Prior to development of the requirements for any particular RFP, a Roster listing employee (with their title) and consultants in their designated role; Company RFP Team, Company Self-Build Team, Shared Resource or Unassigned Company Resource. When the IO is appointed, this Roster shall be provided to him/her. The Roster shall be placed in the RFP Communication Tool Kit SharePoint Site so that any Company personnel can access the database to determine the identity of the respective teams and Shared Resources.

B. Upon the finalization of the Roster for the RFP, the Energy Contract Manager shall verify that all employees (whether full-time, part-time, temporary, or contract) and consultants involved in the competitive bidding process, such as members of the Company RFP Team, the Company Self-Build Team, Shared Resources or Unassigned Company Resources, have acknowledged receipt of the Code of Conduct and his or her responsibility to comply with the Code of Conduct by submitting the Code of Conduct Acknowledgement (with electronic acknowledgment being acceptable). If an employee or consultant is later added to a team, the Energy Contract Manager shall also verify that such employee or consultant has submitted the Code of Conduct Acknowledgment.

C. Prior to any solicitation for comments or questions to the RFP, establishment of the Company email address to accept requests for information from Proposers, including the Company Self-Build Team or any Affiliate Team.

D. Prior to the drafting of any documents for any particular RFP, establishment of the Company-secured site that houses the accessible database (such as SharePoint).

## **VII. WHEN THE CODE OF CONDUCT TERMINATES**

- A. The Code of Conduct for a specific RFP will terminate after the following two conditions are met when:
- a. the final contract(s) for RFPs conducted under the Framework with the successful proposer(s) is/are executed, or when written notice of termination of the RFPs to be conducted under the Framework is provided by the Manager of Energy Procurement or his/her designee to the IO and the Commission, and
  - b. a certification of Code of Conduct compliance by all employees participating in the specific RFP process is submitted by affidavit by the Company Executive in Charge.

## **VIII. DOCUMENTATION FORMS**

The following documentation forms may be utilized by those Company personnel involved in the RFP. These forms may be amended from time to time as necessary. Additional forms may also be developed as determined necessary.

- Code of Conduct Acknowledgement
- Communications Log
- Roster

## **IX. APPLICABILITY OF THE ATRs**

Except as specifically made applicable under Section V.C.1.i of the ATRs with respect to wholesale power procurement from Affiliates, the ATRs shall not apply to RFP matters covered by the Framework, the Code of Conduct and this Procedures Manual as it relates to the Companies' interactions between the Company RFP Teams and Affiliate Teams. Reference to the ATRs in the Code of Conduct and/or this Manual are specifically

for matters outside the Companies' administration of the RFP; provided, however, that such applicability may be revised as necessary and as may be directed by the Commission for any RFP.<sup>1</sup>

---

<sup>1</sup> See Decision and Order No. 35962, filed on December 19, 2018, in Docket 2018-0065, at 56-57.

**DRAFT**

**REQUEST FOR PROPOSALS**

**FOR**

**COMMUNITY-BASED RENEWABLE ENERGY TRANCHE 1**

**ISLAND OF HAWAI‘I**

DECEMBER 1, 2020

Docket No. 2015-0389

*Appendix D – PowerAdvocate User Information*

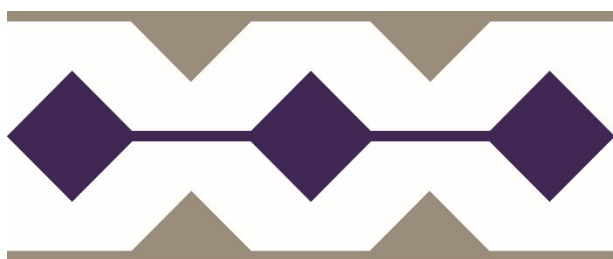

**Hawai‘i  
Electric  
Light**



## Sourcing Intelligence Quick Start for Suppliers

### Logging In

1. Launch a web browser and go to [www.poweradvocate.com](http://www.poweradvocate.com)
2. Click the orange **Login** button.
3. Enter your account **User Name** and **Password** (both are case-sensitive) and click **Login**.
4. Click the **Events** tab if it is not already displayed.

### Dashboard

Your Dashboard lists the events you have been invited to. A line divides currently accessible events from others.

Click to view Events

Click to view the event's Status tab

Buyer filter

Navigation bar

Buying entity

Number of unread/total messages

Click to view the event's Messaging tab

Click numbers to view event tabs

Datashheet available

No datashheet available

- Click an event name to view its Status tab, which displays a summary of your activity and key event dates. To view specific details of an event, click the buttons 1-5 to view the corresponding tab.
- To return to the Dashboard, click **Dashboard** in the navigation bar at the top of the window.
- An event will not appear on your Dashboard until you have been added as a participant.



## Downloading Bid Packages

All of the Buyer's bid package documents (if any) are centrally stored on the PowerAdvocate Platform. To view bid documents, click "1" on your Dashboard or on the **1. Download Documents** tab from within the event.

Document Description	Issue Date	Ref ID	File Name	File Size	Download
<input type="checkbox"/> Pre Bid Test Doc	01/15/18		Pre_Bid_Test_Doc.docx	11.63 KB	

- You can access the **Bid** sub-tab after the event opens. You can access Buyer documents before the event is opened from the **Pre-Bid** sub-tab, if the Buyer utilizes this feature.
- To view or download a document, click the file name.
- To download multiple documents:
  1. Select the checkbox in the Download column for each document you wish to download or click **Select All**.
  2. Click **Download Selected Files**.

## Uploading Documents

To upload your documents, click "2" on your Dashboard, or on the **2. Upload Documents** tab from within the event.

- Do not upload any files to the Pre-Bid tab.
- To upload a document to the Bid tab:
  1. Specify a **Document Type** (Reference ID can be left blank).
  2. Click **Choose File**, navigate to and select the document, and then click Open; multiple files can also be compressed into one .zip file for upload.
  3. Click **Submit Document**.



## Datasheets

Datasheets (3. Commercial Data, 4. Technical Data, 5. Pricing Data) will not be used in this RFP event. All Proposal information will be uploaded for submission through the 2. Upload Documents tab. Buttons/tabs are grayed out if the event is not using a particular type of datasheet.

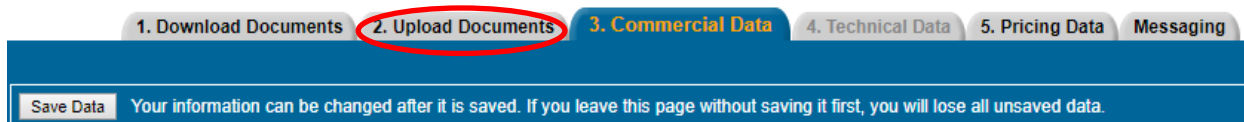

## Communicating with the Bid Event Coordinator/Company Contact

Suppliers should use Email to contact the Bid Event Coordinator/Company Contact while the bid event is open. In these CBRE RFPs, PowerAdvocate Messaging will not be used.

## Getting More Information

- Click **Help** on the navigation bar to display online help.



- Supplier documentation can be downloaded from the online help system.
- Call PowerAdvocate Support at 857-453-5800 (Mon-Fri, 8 a.m. to 8 p.m. Eastern Time) or e-mail [support@poweradvocate.com](mailto:support@poweradvocate.com).



**DRAFT**

**REQUEST FOR PROPOSALS**

**FOR**

**COMMUNITY-BASED RENEWABLE ENERGY TRANCHE 1**

**ISLAND OF HAWAI‘I**

DECEMBER 1, 2020

Docket No. 2015-0389

*Appendix E – Mutual Confidentiality and  
Non-Disclosure Agreement*

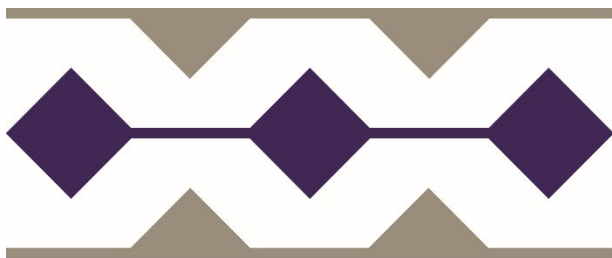

**Hawai‘i  
Electric  
Light**

**APPENDIX E**  
**MUTUAL CONFIDENTIALITY AND NON-DISCLOSURE AGREEMENT**  
Independent Power Producers – (“IPPs”)

This Mutual Confidentiality and Non-Disclosure Agreement (this “Agreement”) is effective as of \_\_\_\_\_, 20\_\_\_\_ (the “Effective Date”) between [INSERT NAME OF IPP], a [State of incorporation/organization] [type of entity] (“IPP”) and Hawaiian Electric Company, Inc., Maui Electric Company, Limited, and Hawaii Electric Light Company, Inc., each a Hawaii corporation (collectively, the “Companies”). In consideration of the mutual promises contained in this Agreement, including the provision of Confidential Information (as defined below) by either party to the other hereunder, and other good and valuable consideration, the receipt and sufficiency of which are hereby acknowledged, the parties agree as follows:

1. Background

The Companies have or intend to issue a Request for Proposals (“RFP”) for Community-Based renewable energy projects. The IPP has or intends to submit one or more proposals for a nominal [ ] MW [TYPE OF FACILITY] facility located at [LOCATION] on the island of Hawai‘i, State of Hawai‘i (“Proposal”).

In connection with the IPP’s proposed project, the Companies may conduct an interconnection requirements study (“IRS”) to establish the requirements for interconnection of the IPP’s proposed project to the Companies’ electric grid. The RFP process may also result in the award of a potential power purchase agreement, the terms of which must be agreed upon by the parties (“PPA Negotiations”). For purposes of this Agreement the term “Project” refers to the RFP, Proposal, potential IRS and PPA Negotiations.

In order to evaluate the Project, either party may from time to time provide to the other party certain Confidential Information. The parties are willing to provide such Confidential Information to each other upon the terms and conditions of this Agreement.

2. Confidential Information

Except as set forth in Section 3 (Exclusions from Confidential Information) below, “Confidential Information” means all non-public, confidential or proprietary information disclosed by either party (the “Provider”) to the other party (a “Recipient”) its affiliates and its and their directors, officers, employees, agents, advisors, consultants (including, without limitation, financial advisors, counsel and accountants) and controlling entities or individuals (collectively, “Representatives”) whether disclosed orally or disclosed or accessed in written, electronic or other form of media, and whether or not marked or otherwise identified as “confidential,” including, without limitation:

(a) all information concerning the Provider and its affiliates’, and their customers’, suppliers’ and other third parties’ past, present and future business affairs including, without limitation, finances, customer information, supplier information, products, services, designs,

processes, organizational structure and internal practices, forecasts, sales and other financial results, records and budgets, business, marketing, development, sales and other commercial information and strategies;

(b) information concerning the Companies' generation, transmission, and distribution systems (e.g., engineering and operating characteristics of the Companies' transmission lines and substations) ("Critical Infrastructure Confidential Information");

(c) the Provider's unpatented inventions (whether or not they are patentable), ideas, methods and discoveries, techniques, formulations, development plans, trade secrets, know-how, unpublished patent applications and other confidential intellectual property;

(d) all designs, specifications, documentation, components, source code, object code, images, icons, audiovisual components and objects, schematics, drawings, protocols, processes, and other visual depictions, in whole or in part, of any of the foregoing;

(e) any third-party confidential information included with, or incorporated in, any information provided by the Provider to the Recipient or its Representatives; and

(f) all notes, analyses, compilations, reports, forecasts, studies, samples, data, statistics, summaries, interpretations and other materials ("Notes") prepared by or for the Recipient or its Representatives that contain, are based on, or otherwise reflect or are derived from, in whole or in part, any of the foregoing.

### 3. Exclusions from Confidential Information

Except as required by applicable federal, state, or local law or regulation, the term "Confidential Information" as used in this Agreement shall not include information that:

(a) at the time of disclosure is, or thereafter becomes, generally available to and known by the public other than as a result of, directly or indirectly, any violation of this Agreement by the Recipient or any of its Representatives; provided, however, that Confidential Information shall not be disqualified as Confidential Information (i) merely because it is embraced by more general or generic information which is in the public domain or available from a third party, or (ii) if it can only be reconstructed from information taken from multiple sources, none of which individually shows the whole combination (with matching degrees of specificity);

(b) at the time of disclosure is, or thereafter becomes, available to the Recipient on a non-confidential basis from a third-party source, provided that such third party is not and was not prohibited from disclosing such Confidential Information to the Recipient by a contractual or other obligation to the Provider;

(c) was known by or in the possession of the Recipient or its Representatives, as established by documentary evidence, prior to being disclosed by or on behalf of the Provider pursuant to this Agreement;

(d) was or is independently developed by the Recipient, as established by documentary evidence, without reference to or use of, in whole or in part, any of the Provider's Confidential Information; or

(e) was or is learned of established entirely from public sources, as established by documentary evidence, without reference to or use of, in whole or in part, any of the Provider's Confidential Information.

The parties acknowledge and understand that the confidentiality obligations of this Agreement apply only to the Confidential Information shared in connection with the Project. The parties may share other information with each other under other agreements, provisions or understandings which are not related to the Project. Such information sharing shall be subject to the provisions of the agreements and confidentiality provisions associated thereto and this Agreement shall not be construed to infringe upon or apply to such agreements or provisions.

#### 4. Non-Disclosure of Confidential Information

Unless otherwise agreed to in writing by the Provider, the Recipient agrees as follows:

(a) except as required by law, not to disclose or reveal any Confidential Information to any person or entity other than its Representatives who are actively and directly participating in the evaluation of the Project or who otherwise need to know the Confidential Information for the purpose of evaluating the Project.

(b) not to use Confidential Information for any purpose other than in connection with its evaluation of the Project or the consummation of the Project.

(c) except as required by law, not to disclose to any person or entity (other than those of its Representatives who are actively and directly participating in the evaluation of the Project or who otherwise need to know for the purpose of evaluating the Project) any information about the Project, or the terms or conditions or any other facts relating thereto, including, without limitation, the fact that discussions are taking place with respect thereto or the status thereof, or the fact that Proprietary Information has been made available to the Recipient or its Representatives.

(d) to use diligent efforts to safeguard and protect the confidentiality of the Confidential Information, including, at minimum, implementing the same commercial measures that the Recipient uses to protect its own confidential information. Before disclosing the Confidential Information to any Representative, the Recipient will inform such Representative of the confidential nature of such information, their duty to treat the Confidential Information in accordance with this Agreement and shall ensure that such Representative is legally bound by the terms and conditions of this Agreement or subject to confidentiality duties or obligations to the Recipient that are no less restrictive than the terms and conditions of this Agreement.

(e) Any provision herein to the contrary notwithstanding, the Companies may disclose Confidential Information to the State of Hawai'i Public Utilities Commission ("Commission")

and/or the State of Hawai'i Division of Consumer Advocacy (including their respective staffs) provided that such disclosure is made under a protective order entered in the docket or proceeding with respect to which the disclosure will be made or any general protective order entered by the Commission.

5. Required Disclosure and Notice

If the parties or any of their Representatives become legally compelled (by deposition, interrogatory, request for documents, subpoena, civil investigative demand, court order, or similar process) to disclose any of the Confidential Information, the compelled party shall undertake reasonable efforts to provide the other party with notice within three (3) business days of such requirement or advice prior to disclosure so that the other party may (a) seek a protective order or other appropriate remedy, (b) consult with the other party with respect to the compelled party taking steps to resist or narrow the scope of such requirement or advice, and/or (c) waive compliance, in whole or in part, with the terms of this Agreement. If such protective order or other remedy is not obtained, or the other party waives compliance with the provisions hereof, the compelled party agrees to furnish only that portion of the Confidential Information which it is legally required to so furnish and, at the request of the other party, to use reasonable efforts to obtain assurance that confidential treatment will be accorded such Confidential Information, it being understood that such reasonable efforts shall be at the cost and expense of the party whose Confidential Information has been sought. In any event, neither the IPP nor any of its Representatives will oppose action by the Companies to obtain an appropriate protective order or other reliable assurance that confidential treatment will be accorded the Confidential Information.

6. Return or Destruction of Confidential Information

At any time during or after the term of this Agreement, at the Provider's written request, and in any event, upon the termination of the Agreement, the Recipient shall certify within ten (10) business days that it has destroyed all Confidential Information by using industry standard data elimination methods used to prevent unauthorized disclosure of information, and for Personally Identifiable Information (defined as personally identifiable information of individuals, and any information that may be used to track, locate or identify such individuals (or which is otherwise protected by privacy laws), including any automatically generated information (such as IP addresses and other customer identifiers) that identifies or is unique or traceable to a particular individual or computer or other electronic device capable of accessing the internet, including without limitation, name, address, telephone number, social security number, credit card account numbers, email addresses, user identification numbers or names and passwords, which is disclosed to the Recipient or its subcontractors in connection with this Agreement by the Provider, which products and services are used or intended to be used for personal, family or household purposes), such methods shall be consistent with Hawaii Revised Statutes Chapter 487-R; provided, however, that with respect to Confidential information in tangible form, the Recipient may return such Confidential Information to the Provider within ten (10) business days in lieu of destruction. The Recipient's sole obligation with respect to the disposition of any Notes shall be to redact or otherwise expunge all such Confidential Information from such Notes and certify to the Provider that it has so redacted or expunged the Confidential Information. Notwithstanding the foregoing, with respect to any Confidential Information stored in Recipient's disaster recovery backups or

other electronic archives, Recipient is not required to destroy such Confidential Information if it would impose a material cost or burden; provided, however, such Confidential Information shall be destroyed when such archives are destroyed in accordance with Recipient's records retention policies.

7. Authority

Each party represents and warrants that it has full power and authority to enter into and perform this Agreement, and the person signing this Agreement on behalf of each has been properly authorized and empowered to enter into this Agreement, understands it and agrees to be bound by it.

8. No Representations or Warranties

Neither the Provider nor any of its Representatives make any express or implied representation or warranty as to the accuracy or completeness of any Confidential Information disclosed to the Recipient hereunder, and the Recipient agrees that it is not entitled to rely on the accuracy or completeness of any Confidential Information. Neither the Provider nor any of its Representatives shall be liable to the Recipient or any of its Representatives relating to or arising from the use of any Confidential Information or for any errors therein or omissions therefrom. Notwithstanding the foregoing, the Recipient shall be entitled to rely solely on such representations and warranties regarding Confidential Information as may be made to it in any final agreement relating to the Project, subject to the terms and conditions of such agreement.

9. No Other Obligations

Neither this Agreement nor the disclosure of the Confidential Information shall result in any obligation on the part of either party to enter into any further agreement with the other with respect to the subject matter hereof or otherwise, to purchase any products or services from the other, or to require either party to disclose any further information to the other. Nothing in this Agreement shall be deemed to constitute either party hereto as partner, agent or representative of the other party or to create any fiduciary relationship between the parties. Either party may offer products or services which are competitive with products or services now offered or which may be offered by the other. Subject to the express terms and conditions of this Agreement, neither this Agreement nor discussions and/or communications between the parties will impair the right of either party to develop, make, use, procure, and/or market any products or services, alone or with others, now or in the future, including those which may be competitive with those offered by the other. Whether or not the Project is consummated, neither party shall issue a press release or release any information to the general public concerning such transaction or the absence thereof without the express prior written consent of the other, and the parties agree that neither party will use the other's name whether by including reference to the other in any press release, list of customers advertising that its services are used by Companies or otherwise, without written authorization by the respective party's authorized representative.

10. Property Rights in Confidential Information

All Confidential Information shall remain the sole and exclusive property of the Provider and nothing in this Agreement, or any course of conduct between the parties shall be deemed to grant to the Recipient any license or rights in or to the Confidential Information of the Provider, or any part thereof. Unless otherwise expressly agreed in a separate license agreement, the disclosure of Confidential Information to the Recipient will not be deemed to constitute a grant, by implication or otherwise, of a right or license to the Confidential Information or to any patents or patent applications of the Provider.

11. Publicly Traded

The IPP acknowledges that the Companies' holding company is a publicly traded company, and that Confidential Information of the Companies may constitute material, non-public information with respect to the Companies. The IPP understands, and will advise its Representatives to whom Confidential Information of the Companies is disclosed, of the restrictions imposed by the United States securities laws on (a) the purchase or sale of securities by any person in possession of material, non-public information with respect to such securities, and (b) the communication of material, non-public information with respect to securities to a person who may purchase or sell such securities in reliance upon such information.

12. Remedies

(a) Each party acknowledges and agrees that any breach or threatened breach of this Agreement may give rise to an irreparable injury to the Provider or its Representatives, for which compensation in damages is likely to be an inadequate remedy. Accordingly, in the event of any breach or threatened breach of this Agreement by the Recipient or its Representatives, the Provider shall be entitled to seek equitable relief, including in the form of injunctions and orders for specific performance, in addition to all other remedies available at law or in equity.

(b) In the event that the Recipient learns of dissemination, disclosure, or use of the Confidential Information which is not permitted by this Agreement, the Recipient shall notify the Provider immediately in writing and shall use reasonable efforts to assist the Provider in minimizing damages from such disclosure. Such remedy shall be in addition to and not in lieu of any other rights or remedies available to the Provider at law or in equity.

13. Cumulative Remedies

No rights or remedy herein conferred upon or reserved to either party hereunder is intended to be exclusive of any other right or remedy, and each and every right and remedy shall be cumulative and in addition to any other right or remedy under this Agreement, or under applicable law, whether now or hereafter existing.

14. Notice

(a) By delivering written notice, either party may notify the other that it no longer wishes to receive or provide Confidential Information. Any further information received or

provided by the party who received such notice following receipt of such notice, shall not be subject to the protection of this Agreement.

(b) All notices, consents and waivers under this Agreement shall be in writing and will be deemed to have been duly given when (i) delivered by hand, (ii) sent by electronic mail ("E-mail") (provided receipt thereof is confirmed via E-mail or in writing by recipient), (iii) sent by certified mail, return receipt requested, or (iv) when received by the addressee, if sent by a nationally recognized overnight delivery service (receipt requested), in each case to the appropriate addresses and E-mail Addresses set forth below (or to such other addresses and E-mail addresses as a party may designate by notice to the other party):

**(1) Companies:**

**By Mail:**

Hawaiian Electric Company, Inc.  
P.O. Box 2750  
Honolulu, Hawaii 96840  
Attn: Manager of Procurement, Renewable Acquisition Division

**Delivered By Hand or Overnight Delivery:**

Hawaiian Electric Company, Inc.  
Central Pacific Plaza  
220 South King St, 21<sup>st</sup> Floor  
Honolulu, HI 96813  
Attn: Manager of Procurement, Renewable Acquisition Division

**By E-mail:**

Hawaiian Electric Company, Inc.  
Attn: Manager of Procurement, Renewable Acquisition Division  
Email: [renewableacquisition@hawaiianelectric.com](mailto:renewableacquisition@hawaiianelectric.com)

With a copy to:

**By Mail:**

Hawaiian Electric Company, Inc.  
Legal Department  
P.O. Box 2750  
Honolulu, Hawaii 96840

**Delivered By Hand or Overnight Delivery:**

Hawaiian Electric Company, Inc.  
American Savings Bank Tower  
1001 Bishop Street, Suite 1100  
Honolulu, Hawaii 96813  
Attn: Legal Department



By E-mail:

Hawaiian Electric Company, Inc.  
Legal Department  
Email: [legalnotices@hawaiianelectric.com](mailto:legalnotices@hawaiianelectric.com)

**(2) [IPP]**

By Mail:

[INSERT ADDRESS/CONTACT]

Delivered By Hand or Overnight Delivery:

[INSERT ADDRESS/CONTACT]

By E-mail:

[INSERT ADDRESS/CONTACT]

With a copy to:

By Mail:

[INSERT ADDRESS/CONTACT]

Delivered By Hand or Overnight Delivery:

[INSERT ADDRESS/CONTACT]

By E-mail:

[INSERT ADDRESS/CONTACT]

15. No Waiver

Except as otherwise provided in this Agreement, no delay or forbearance of a party in the exercise of any remedy or right will constitute a waiver thereof, and the exercise or partial exercise of a remedy or right shall not preclude further exercise of the same or any other remedy or right.

16. Governing Law

This Agreement is made under, governed by, construed and enforced in accordance with, the laws of the State of Hawaii. Any action brought with respect to the matters contained in this Agreement shall be brought in the federal or state courts located in the State of Hawaii. Each party agrees and irrevocably consents to the exercise of personal jurisdiction over each of the parties by such courts and waives any right to plead, claim or allege that the State of Hawaii is an inconvenient forum or improper venue.

17. Attorneys' Fees and Costs

If there is a dispute between the parties and either party institutes a lawsuit, arbitration, mediation or other proceeding to enforce, declare, or interpret the terms of this Agreement, then the prevailing party in such proceeding shall be awarded its reasonable attorneys' fees and costs.

18. Assignment Prohibited

This Agreement shall be binding upon and inure to the benefit of the parties hereto and their respective successors, legal representatives, and permitted assigns. Neither party shall have the right to assign any of its rights, duties or obligations under this Agreement, by operation or law or otherwise, without the prior written consent of the other party. Any purported assignment in violation of this section shall be null and void.

19. No Third Party Beneficiaries

Nothing expressed or referred to in this Agreement will be construed to give any person or entity other than the parties any legal or equitable right, remedy, or claim under or with respect to this Agreement or any provision of this Agreement. This Agreement and all of its provisions and conditions are for the sole and exclusive benefit of the parties and their successors and permitted assigns.

20. Entire Agreement

This Agreement constitutes the entire agreement between the parties relating to the subject matter hereof, superseding all prior and contemporaneous agreements, understandings or undertakings, oral or written with respect to the subject matter. Any amendment or modification of this Agreement or any part hereof shall not be valid unless in writing and signed by the Parties. Any waiver hereunder shall not be valid unless in writing and signed via by the party against whom waiver is asserted.

21. Term and Survival

This Agreement shall remain in full force and effect for a period of two (2) years from the Effective Date. All confidentiality obligations within this Agreement shall survive following expiration or termination of this Agreement.

22. Severability

If any term or provision of this Agreement, or the application thereof to any person, entity or circumstances is to any extent invalid or unenforceable, the remainder of this Agreement, or the application of such term or provision to persons, entities or circumstances other than those as to which it is invalid or unenforceable, shall not be affected thereby, and each term and provision of this Agreement shall be valid and enforceable to the fullest extent permitted by law, and the parties will take all commercially reasonable steps, including modification of the Agreement, to preserve the economic "benefit of the bargain" to both parties notwithstanding any such aforesaid invalidity or unenforceability.

23. Negotiated Terms

The parties agree that the terms and conditions of this Agreement are the result of negotiations between the parties and that this Agreement shall not be construed in favor of or against any party by reason of the extent to which any party or its professional advisors participated in the preparation of this Agreement.

24. Counterparts and Electronic Signatures

This Agreement may be executed in counterparts, each of which shall be deemed an original, and all of which shall together constitute one and the same instrument binding all parties notwithstanding that all of the parties are not signatories to the same counterparts. For all purposes, duplicate unexecuted and unacknowledged pages of the counterparts may be discarded and the remaining pages assembled as one document. The parties agree that this Agreement and any subsequent writings, including amendments, may be executed and delivered by exchange of executed copies via E-mail or other acceptable electronic means, and in electronic formats such as Adobe PDF or other formats mutually agreeable the parties which preserve the final terms of this Agreement or such writing. A party's signature transmitted by E-mail or other acceptable electronic means shall be considered an "original" signature which is binding and effective for all purposes of this Agreement.

*[Signature Page Follows]*

IN WITNESS WHEREOF, each party has caused this Agreement to be executed on its behalf by a duly authorized representative, all as of the Effective Date.

HAWAIIAN ELECTRIC COMPANY, INC.

By: \_\_\_\_\_  
Print Name: \_\_\_\_\_  
Its: \_\_\_\_\_

MAUI ELECTRIC COMPANY, LIMITED

By: \_\_\_\_\_  
Print Name: \_\_\_\_\_  
Its: \_\_\_\_\_

HAWAII ELECTRIC LIGHT COMPANY, INC,

By: \_\_\_\_\_  
Print Name: \_\_\_\_\_  
Its: \_\_\_\_\_

“Companies”

[Insert Name of IPP]

\_\_\_\_\_  
By: \_\_\_\_\_  
Print Name: \_\_\_\_\_  
Its: \_\_\_\_\_

“IPP”

**DRAFT**

**REQUEST FOR PROPOSALS**

**FOR**

**COMMUNITY-BASED RENEWABLE ENERGY TRANCHE 1**

**ISLAND OF HAWAI‘I**

DECEMBER 1, 2020

Docket No. 2015-0389

*Appendix F – Description of Available Sites*



**Hawai‘i  
Electric  
Light**

## **HAWAI‘I ELECTRIC LIGHT COMMUNITY-BASED RENEWABLE ENERGY PROJECTS RFP DESCRIPTION OF AVAILABLE SITES**

### **Land Request for Information**

On June 15, 2020, Hawaiian Electric issued a Land Request for Information (“Land RFI”) seeking information on available land and rooftop space for potentially siting future utility scale renewable energy projects on the islands of O‘ahu, Maui, Moloka‘i, and Hawai‘i. This effort is a new solicitation from the previous Land RFI that was issued on December 12, 2016 in advance of the Company’s Stage 1 and Stage 2 RFPs. The information that has been gathered through this RFI is available upon request by following the instructions at <http://hawaiianelectric.com/landrfi>.

This information is being provided for proposers’ consideration only. Project proposals submitted in response to this RFP are not required to be sited at a location identified through the Land RFI. Hawai‘i Electric Light also makes no representations as to the suitability of the listed sites for renewable energy production with regard to resource quality, interconnection constraints, zoning and permitting issues, community support, or other issues. Proposers should perform their own evaluation of these factors in determining whether a site is suitable for renewable energy project development. After further evaluation, proposers that are interested in any of the identified sites are invited to engage in further discussions directly with landowners to negotiate any required rights to use the property.

### **Additional Information**

Additionally, the following links to a few publicly available resources relating to renewable energy project siting and development from the Hawai‘i State Energy Office are being provided for use at proposers’ sole discretion:

### **Project Permitting Assistance and Resources**

<http://energy.hawaii.gov/developer-investor/project-permitting-assistance-and-resources>

Provides numerous resources to support more informed and appropriate project siting and permitting, including the Permit Guide, Renewable Energy Permitting Consultants, DOH, ePermitting Portal, Renewable EnerGIS, Permitting Wizard, and the Renewable Energy Projects Directory.

### **Hawai‘i Clean Energy Programmatic Environmental Impact Statement**

<http://energy.hawaii.gov/testbeds-initiatives/hawaii-clean-energy-peis/peis-overview>

The Hawaii Clean Energy Programmatic Environmental Impact Statement (PEIS) analyzes, at a programmatic level, the potential environmental impacts of clean energy activities and technologies in the following clean energy categories: (1) Energy Efficiency, (2) Distributed Renewables, (3) Utility-Scale Renewables, (4) Alternative Transportation Fuels and Modes, and (5) Electrical Transmission and Distribution.

### **Hawai'i Statewide GIS Program**

<http://planning.hawaii.gov/gis/>

Provides Hawai'i GIS data and other resources to support site identification and analysis.

### **Aloha Aina: A Framework for Biocultural Resource Management in Hawai'i's Anthropogenic Ecosystems**

[https://nmshawaiihumpbackwhale.blob.core.windows.net/hawaiihumpbackwhale-prod/media/archive/council/pdfs/aloha\\_aina.pdf](https://nmshawaiihumpbackwhale.blob.core.windows.net/hawaiihumpbackwhale-prod/media/archive/council/pdfs/aloha_aina.pdf)

A framework developed by the Hawaiian Islands Humpback Whale National Marine Sanctuary Advisory Council to integrate Native Hawaiian and Western scientific management approaches toward ecosystem management. While intended for the Sanctuary, this document provides useful insight into successful collaboration in Hawai'i.

**DRAFT**  
**REQUEST FOR PROPOSALS**  
**FOR**  
**COMMUNITY-BASED RENEWABLE ENERGY TRANCHE 1**  
**ISLAND OF HAWAI‘I**

DECEMBER 1, 2020

Docket No. 2015-0389

*Appendix G – Self Build Option and  
Self Build Option Team Certification Form*

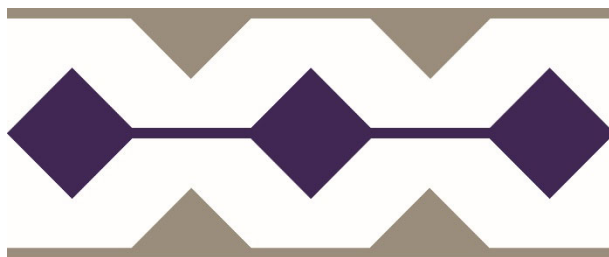

**Hawai'i  
Electric  
Light**



## Appendix G - Self Build Option

### Overview

To the extent that there are Self Build Option (“SBO”) Proposals to the RFP, the Company will endeavor to evaluate these SBO Proposals on a fair basis compared to third party Proposals. As described in Section 1.9.1 of the RFP, “[t]he Competitive Bidding Framework allows the Company the option to offer a Proposal(s) in response to this RFP (“Self-Build Option” or “SBO”). Accordingly, the Company must follow certain requirements and procedures designed to safeguard against and address concerns associated with: (1) preferential treatment of the SBO or members, agents or consultants of the Company formulating the SBO (the “Self-Build Team”); and (2) preferential access to proprietary information of the Self-Build Team.” Any Proposal from the Self-Build Team will be required to comply with the provisions in the Framework for Competitive Bidding (“Framework”) as well as this RFP.

In addition to its Proposal, the Self-Build Team will be required to submit Attachment 1 to this Appendix G, Self-Build Option Team Certification Form, acknowledging it has followed the rules and requirements of the RFP to the best of its ability and has not engaged in any collusive actions or received any preferential treatment or information providing an impermissible competitive advantage to the Self-Build Team over other proposers responding to this RFP, as well as adherence to PPA or Mid-Tier SFC terms and milestones required of all proposers and the SBO’s proposed cost protection measures.

Pursuant to the Framework and as set forth in the RFP Schedule, the Company will require that the Proposal for the SBO(s) be submitted electronically through the Electronic Procurement Platform a minimum of one (1) Day before other Proposals are due.

Except where specifically noted, a SBO Proposal must adhere to the same price and non-price Proposal requirements as required of all Proposers.

As described in Section 3.8.4 of the RFP, if selected, a Self-Build Proposer will not be required to enter into a PPA or Mid-Tier SFC with the Company. However, the SBO will be held to the same performance metrics and milestones set forth in the RDG PPA or Mid-Tier SFC to the same extent as all Proposers, as attested to in the SBO’s Appendix G Attachment 1 Self Build Option Certification submittal. If liquidated damages are assessed, they will be paid from shareholder funds and returned to customers through the Purchased Power Adjustment Clause (“PPAC”),

In lieu of price components, the SBO will need to provide their total project capital costs, any associated annual O&M costs, as well as annual revenue requirements by year. (See Appendix B Section 2.0.) The SBO shall submit revenue requirement worksheets with their Proposal that support their annual revenue requirements estimates. A starter revenue requirements template file can be requested by the Self-Build Team via email to the RFP Email Address or through the PowerAdvocate Messaging function once the RFP event opens. The revenue requirements

worksheets submitted will be customized to reflect the details of the Project's Proposal. All assumptions used will be reflected in an assumptions input tab.

### **SBO Total Project Capital Cost**

The following is a high-level breakdown followed by a narrative explanation of the total capital cost estimate for a potential SBO Proposal. The total project capital cost (and annual O&M costs) will be used to calculate the Revenue Requirement, which will then be used to calculate a LB for Proposal comparison purposes. The categories of costs include:

- Facility
  - EPC Contract
  - Allowance for Change Orders
  - Equipment
  - Owner's Cost
- Outside Services
- Interconnection
- Overheads
- AFUDC

These costs will be identified in Section 2.3.2.2 of the SBO Proposal. (See Appendix B Section 2.3.2.2.)

- Facility (including any generation and storage components) - This line item, to the extent applicable, should include costs such as:

#### Engineering, Procurement, and Construction ("EPC") Contract

The total cost estimate of the facility is the projected EPC contract cost including the design of the facility up to the high-voltage terminals of the step-up transformers, procurement of all the equipment, and services necessary to build the facility and construction and commissioning of the facility.

#### Allowance for Change Orders

This allocation accounts for items such as additional requirements resulting from unforeseen conditions, unexpected permitting requirements, force majeure events, unanticipated interferences, different interpretations of design requirements, material unavailability, and longer than normal delivery times.

#### Equipment

This cost includes the generator and the facility equipment that support the operation of the generator and the distribution of electrical power around the station, as applicable. Engineering and testing services required to ensure that the equipment is properly functioning at the site, training and documentation necessary to operate and maintain the equipment, and performance guarantees may also be included here.

### Owner's Cost

Owner's costs for the facility are all the costs necessary for the design, permitting, procurement, construction, and commissioning of the facility and for the preparation of the Proposal that are not included in the major contracts (i.e. EPC). The Companies' Labor includes Project Management, Station Operator training and commissioning, Environmental, Safety, Legal, Corporate Communications, Community and Government Relations, Engineering, and Regulatory Affairs. Company Labor for the preparation of the Proposal is also included here. For purposes of recovery, only the incremental costs of Labor will be subject to separate recovery.

- Outside Services - This line item, to the extent applicable, should include costs such as:
  - Construction Management to oversee the EPC contractor
  - Legal for the preparation of the Environmental Impact Statement and PUC process
  - Engineering for development and evaluation of the project technical specifications, Interconnection Requirements Study (IRS), and emissions testing
  - Environmental to conduct the Environmental Impact Statement (EIS) and Air Permit consulting
  - General Services such as surveys, land appraisals, Environmental Condition Reports, public relations, office trailer rental, archeological services, landscaping, miscellaneous permits, builder's risk insurance, switchgear testing, hazard analysis, painting, monitoring services, and moving costs.
  - Material costs including spare parts, furnishings, IT equipment, appliances, generator system initial fills (fuels, oils, water), and telecommunications equipment for the station.
  - Travel costs required to inspect other similar facilities, observe final acceptance testing of critical equipment, and station operators' factory training
- Interconnection – This line item covers all interconnection costs that a similarly situated IPP would be responsible for as described in RFP Section 2.3.5, and to the extent applicable, should include costs such as:

### Distribution Line

The cost estimate includes the design, procurement, and construction of any new distribution infrastructure needed to interconnect with the designated substation.

### Switchyard

Work at the switchyard will include design, procurement, and construction of the switchyard and the interfaces between the high voltage terminals of the generator step-up transformers and the circuit to which it will be connected. Site preparation

of the switchyard and the design, procurement, and installation of the step-up transformers located in the switchyard, are typically included in the EPC contract.

Substation

Work at the designated substation that will include the design, procurement, and construction of the interfaces between the new distribution line and the substation buswork to which it will be connected.

Telecom

Accounts for direct labor, materials, and outside services to install telecommunication requirements for the project.

Project Management

Cost estimate of the project management design, procurement, contracting, and scheduling efforts for the interconnection only. Project management costs for the facility are included in the Owner's Cost estimate above.

- Overhead Costs

Overhead costs for the proposed facility will be estimated by the Company's budgeting software (UI Planner) and represent an allocation for those Company costs that are not attributable to any particular project or operation, but are essential nonetheless. Overheads are comprised of non-productive wages (such as holiday, sick, and vacation pay), employee benefits, payroll taxes, corporate administrative costs, and clearing costs.

- Allowance for Funds Used During Construction ("AFUDC")

The AFUDC will be calculated using the Company's budgeting software (UI Planner) and represents the cost of capital funding for the Project. The Company strives to minimize the cost of the AFUDC by ensuring that Project elements that are used or useful are placed in service as soon as possible, as well as minimizing the amount of time that AFUDC can accumulate, by minimizing the amount of time between expenditures on Project elements and their placement in service.

The SBO Proposal will include a Revenue Requirement for each year, which is calculated from the total project capital cost to determine the revenues needed to recover the cost of the project. The value of the Revenue Requirement Calculation for the Total SBO Project Capital Cost will be included in the Levelized Benefit calculation described below.

## **Annual O&M**

The cost for ongoing O&M (fixed and variable) will be a component of the Revenue Requirement. All O&M should be included in this category, unless captured elsewhere in the Revenue Requirement Calculation, including but not limited to annual O&M expense to maintain facility; property taxes (if applicable), and insurance. As described in RFP Appendix G, a SBO Proposal

will be required to cap its O&M costs at the amount included in the Proposal. Only actual costs will be recovered if such actual costs are lower than the maximum amounts in the Proposal.

### **Annual Revenue Requirement**

The SBO Proposal will include a Revenue Requirement for each year, which is calculated from the total project capital cost to determine the revenues needed to recover the cost of the project. The value of the Revenue Requirement Calculation for the Total SBO Project Capital Cost will be included in the Levelized Benefit calculation.

The following is a narrative description of the proposed revenue requirement calculation and significant assumptions that the SBO Proposal should account for. The objective of a revenue requirement analysis is to illustrate the annual revenue requirements (ARR) for a utility SBO Proposal.

Revenue Requirement is defined as a calculated value which represents the estimated revenues needed from ratepayers which would allow the Company to recover its capital investment and expenses, honor its debt obligations, pay its revenue and income tax liabilities, and pay its preferred shareholders while providing a fair return to its common shareholders for their investment. Specific factors or assumptions related to that particular project will be included in the analysis.

The purpose of a revenue requirement calculation is to determine the annual and total revenue requirements of a capital investment and annual O&M expense needed from customers. The ratemaking formula for revenue requirements is shown below.

$$RR = O + T + D + r(RB)$$

Where:      RR = Revenue Requirements  
              O = Operating and Maintenance Expense  
              T = Tax Expense (Income and Revenue)  
              D = Depreciation Expense  
              r = Rate of Return on Rate Base  
              RB = Rate Base

The Company, in conjunction with the Independent Observer, may also conduct a risk assessment of the SBO Proposal to ensure an appropriate level of customer cost protection measures are included in such proposal.

**APPENDIX G ATTACHMENT 1 - SELF BUILD OPTION TEAM CERTIFICATION**

**Name of SBO Team Contact:** \_\_\_\_\_

**Unique Name of Facility:** \_\_\_\_\_

This Certification of the Self Build Option (SBO) Team's SBO Proposal for Hawaiian Electric Company, Inc.'s ("Company, Maui Electric Company, Ltd., and Hawai'i Electric Light Company, Inc.'s (the "Hawaiian Electric Companies")) Request for Proposals for Community-Based Renewable Energy Projects (RFP) is made as of the date stated below.

**A. COMPLIANCE WITH THE RFP AND CODE OF CONDUCT**

The SBO Team certifies and acknowledges that it will/has:

1. Adhered to the terms of the RFP applicable to the SBO Team, including but not limited to: Section 1.7.1 (proposal submittal requirements) , Section 1.7.3 (certification of non-collusion), Section 1.9 (Procedures for the Self-Build or Affiliate Proposals), and Section 3.4.4 (authorized signatory);
2. Adhered to the technical requirements of the RFP, excluding however those requirements inapplicable to the SBO Team such as execution of the Model RDG PPA or Mid-Tier SFC, pricing formula requirements for independent power producer proposals, submission of a Proposal Fee, dispute resolution, credit requirements, selection of a priority list, and submission of a best and final offer;
3. Complied with the Company's Code of Conduct Procedures Manual, attached as Appendix C to this RFP, with particular attention to the Communications Protocols described in Section C therein with respect to communication with the Company RFP Team.

**B. INDEPENDENT INVESTIGATION**

The SBO Team further certifies and acknowledges that it will/has:

1. Submitted the SBO Proposal based on its own investigations, examinations, and determinations, including assessments of any risks that could have an effect on its obligations under the SBO Proposal.
2. Carefully examined the Company's RFP documents and its appendices and has a clear and comprehensive knowledge of what is required of a Proposer under the RFP, and correspondingly, what is required of the SBO Team.

3. Examined and understands the technical requirements, schedule, and evaluation process as it is laid out in the RFP.

**C. COST PROPOSAL ACKNOWLEDGEMENTS**

The Self Build Team acknowledges and agrees that:

1. Recovery for Project capital costs and O&M costs will be capped at the amount included in the SBO Team's SBO Proposal.
2. Only actual capital costs and O&M costs will be recovered even if such actual costs are lower than the SBO Team's proposed maximum amounts.
3. Costs of developing the proposal must be included in the SBO for evaluation purposes only. Only the incremental costs of developing the SBO Team's proposal will be charged to the project and passed through to customers. Incremental costs for the SBO Proposal not serving as the Parallel Plan and which are not selected to the Final Award Group will not be recoverable from the Companies' customers.

**D. ADHERENCE TO PPA REQUIREMENTS AND MILESTONES**

The Self Build Team acknowledges and agrees that:

1. The SBO Proposal will be consistent with the scope of work and responsibilities of the "Seller" under the terms of the applicable Model PPA or Mid-Tier SFC excluding inapplicable terms related to commercial and legal interactions between the Seller and the Company.
2. The SBO Facility will be designed and constructed to:
  - a. Achieve the Performance Standards identified in Section 3 - Performance Standards, in Attachment B of the applicable Model PPA or Mid-Tier SFC as modified by the IRS (subject to reasonable adjustment agreeable to the Company consistent with the Company's negotiation of such performance standards that would be completed with an independent power producer under similar circumstances);
  - b. Meet the performance metrics as specified in Article 2 of the applicable Model RDG PPA or Attachment C of the Mid-Tier SFC.
    - b.1. For facilities with a photovoltaic generation component, (i) PV System Equivalent Availability Factor, and (ii) Measured Performance Ratio;
    - b.2. For facilities with paired energy storage, (i) Storage Annual Equipment Availability Factor, (ii) Storage Annual Equivalent Forced Outage Factor, and (iii) Storage Capacity Ratio;
  - c. Pass the Acceptance Test specified in Attachment N – Acceptance Test General Criteria of the applicable Model RDG PPA or Attachment F of the Mid-Tier SFC.

- d. Pass the Control System Performance Test specified in Attachment O – Control System Acceptance Test Criteria of the applicable Model RDG PPA or Attachment F of the Mid-Tier SFC;
- e. If applicable, pass the On-line Performance Test specified in Attachment W – BESS Capacity Test of the applicable Model RDG PPA or Attachment H of the Mid-Tier SFC;
- f. If applicable, achieve a Demonstrated Capacity equal to or greater than that indicated in the SBO Proposal as measured pursuant to Attachment W – BESS Capacity Test of the applicable Model RDG PPA or Attachment H of the Mid-Tier SFC;
- g. Meet the project milestones identified in the SBO Proposal no later than the dates specified therein, which shall be consistent with the guaranteed project milestones required in Attachment K – Guaranteed Project Milestones of the applicable Model RDG PPA or Mid-Tier SFC (subject to reasonable adjustment agreeable to the Company consistent with the Company’s negotiation of such milestones that would be completed with an independent power producer under similar circumstances). Notice of completion of milestones and any delay will be provided to PUC and Consumer Advocate.
- h. Achieve the reporting milestones identified in the SBO Proposal no later than the dates specified therein, which shall be consistent with the reporting milestones required in Attachment L – Reporting Milestones of the applicable Model RDG PPA or Mid-Tier SFC (subject to reasonable adjustment agreeable to the Company consistent with the Company’s negotiation of such milestones that would be completed with an independent power producer under similar circumstances). Notice of completion of milestones and any delay will be provided to PUC and Consumer Advocate.
- i. Will be subject to the applicable liquidated damages for the applicable Model RDG PPA or Mid-Tier SFC provisions above. These liquidated damages would be paid from shareholder funds and would be passed through to customers through the Companies’ Power Purchase Adjustment Clause. Notice of any liquidated damages assessed and amounts of such liquidated damages will be provided to PUC and Consumer Advocate.
- j. Will reconfirm requirements in GO7 application and any resulting approval order for such application.
- k. Will provide annual report to PUC and Consumer Advocate on performance metrics.

**E. DECLARATION AND SIGNATURE**

1. The individual(s) that has (have) signed this Self Build Option Team Certification is (are) duly authorized by the SBO Team to execute such on behalf of the SBO Team; and
2. All statements, specifications, data, confirmations, and other information set out in this Self Build Option Team Certification are complete and accurate in all material respects.



IN WITNESS WHEREOF, the SBO TEAM hereby makes the certifications, acknowledgements, and agreements stated herein as of the date stated under the signature of its authorized representative:

Dated at \_\_\_\_\_, \_\_\_\_\_ this \_\_\_\_\_ day of \_\_\_\_\_ 20\_\_\_\_\_.

\_\_\_\_\_  
Signature of SBO Team Representative

\_\_\_\_\_  
Name of SBO Team Representative (please print)

\_\_\_\_\_  
Title of SBO Team Representative (please print)

**DRAFT**  
**REQUEST FOR PROPOSALS**  
**FOR**  
**COMMUNITY-BASED RENEWABLE ENERGY**  
**TRANCHE 1**  
**ISLAND OF HAWAI‘I**

DECEMBER 1, 2020

Docket No. 2015-0389

*Appendix H – Interconnection Facilities and  
Cost Information*



**Hawai‘i  
Electric  
Light**

Hawaii Electric Light Company  
 APPENDIX H - INTERCONNECTION FACILITIES AND COST INFORMATION

Tariff Rule No. 19, approved by the PUC, establishes provisions for Interconnection and Transmission Upgrades (see [Appendix I](#)). The tariff provisions are intended to simplify the rules regarding who pays for, installs, owns, and operates interconnection facilities in the context of competitive bidding. Tariff Rule No. 19 will be utilized as the basis for addressing interconnection and transmission upgrades for any projects developed through this RFP. Proposers will comply with the terms and conditions as specified therein.

To assist Proposers in assessing the impacts of location on potential projects, the per unit cost figures provided in the tables below are to be used to provide an approximate estimated cost for interconnecting, including substation, telecommunications, security, and transmission or distribution line cost to the existing Hawai'i Electric Light System. The per-unit cost figures below should not be used to create a detailed project estimate. A detailed project estimate typically requires a certain level of engineering to assess project site conditions and to factor in other parameters specific to the project.

The Proposer should identify the components assumed for their project and the quantity assumed for each. Each table below provides notes on the assumptions for each of the unit cost estimates. If a Proposer's project requirements are different than what is assumed in the notes, the Proposer should identify each difference and provide an estimated additional cost or savings resulting from those different requirements.

**2.1 Transmission & Distribution Line Interconnection Costs**

Please refer to [Attachment 1](#) (for Projects greater than 250 kW and less than 1 MW) or [Attachment 2](#) (for Projects 1 MW or greater) of this [Appendix H](#) for a single line diagram depicting the required interconnection to the Company's system. Conceptual design is not intended to cover all interconnection requirements. Final interconnection design will be subject to the results of a technical review. The costs below are high level per unit costs for Company T&D work in support of the Project. Please see [Attachment 3](#) for examples of how to apply these per unit costs.

Component	Description	Cost
1	New 12 kV Overhead line (accessible 200' spans)	\$1,188,000 / mile
2	New 12 kV Overhead line (inaccessible 250' spans)	\$1,792,000 / mile
3	12 kV underbuild on existing line (accessible 200' spans)	\$857,000 / mile
4	12 kV underbuild on existing line (inaccessible 250' spans)	\$1,292,000 / mile
5	New 12 kV Underground line	\$2,407,000 / mile
6	12 kV double riser	\$48,000 each
7	12 kV padmount 3ph transformer	\$97,000 each
8	12 kV switchgear	\$229,000 each

Hawaii Electric Light Company  
 APPENDIX H - INTERCONNECTION FACILITIES AND COST INFORMATION

**Notes:**

1. Components 1 and 2 assume wood pole construction.
2. Components 3 and 4 assume no poles need to be replaced.
3. Component 5 assumes two (2) sets of feeder cables.
4. Component 6 assumes a new wood pole is needed.
5. Components 7 and 8 include Company labor and materials to install Company-owned electrical facilities.
6. EXCLUSIONS to costs provided include, but are not limited to, civil infrastructure design/construction (ductlines, MHs, equipment pads, etc.), permitting, regulatory approvals, environmental/archeological studies, survey, easements/land costs, vegetation trimming, and clearing/grading. Proposers should conduct their own due diligence for these costs.
7. Company may share joint occupancy of poles in the project scope. As a result, there may be facilities on the poles, which are neither owned nor controlled by Company. Please contact the appropriate companies and agencies for any work and costs associated with their respective facilities.
8. All estimates are provided in 2022 dollars.

**2.2 Typical CBRE SLD Interconnection Costs (Projects 250 kW and larger, and less than 1 MW)**

Please refer to Attachment 1 of this Appendix H (for Projects greater than 250 kW and less than 1 MW). Conceptual design is not intended to cover all interconnection requirements. Final interconnection design will be subject to the results of the Detailed Evaluation, Technical Review, or an IRS.

Component	Description	Cost
1	All components in <u>Attachment 1</u> except for the line extension from the project to the utility distribution circuit (see <u>Section 2.1</u> above)	\$442,000

**Notes:**

1. Costs include components on the Company side of the demarcation shown in Attachment 1.
2. Costs for line extension from the project to tap the distribution circuit should be estimated using Section 2.1, above.
3. Estimate does not contain any of the following costs:
  - a. Telecommunication infrastructure
  - b. Relay Coordination Study
  - c. Land Cost

Hawaii Electric Light Company  
APPENDIX H - INTERCONNECTION FACILITIES AND COST INFORMATION

- d. Environmental Assessment/Environmental Impact Statement
- e. Project Management
- 4. Substation relay protection requirements have not been identified, so costs are based upon typical line protection relaying requirements.
- 5. All estimates are provided in 2022 dollars.

**2.3 Typical CBRE SLD Interconnection Costs (Projects 1 MW or greater)**

Please refer to Attachment 2 of this Appendix H (for Projects 1 MW or greater). Conceptual design is not intended to cover all interconnection requirements. Final interconnection design will be subject to the results of the Detailed Evaluation, Technical Review, or an IRS.

Component	Description	Cost
1	All components in <u>Attachment 2</u> at Developer site except for the line extension from the project to the utility distribution circuit (see <u>Section 2.1</u> )	\$480,000
2	Components at Company Substation including DTT and relaying requirements	\$356,000 / site

**Notes:**

- 1. Costs includes components on the Company side of the demarcation shown in Attachment 2.
- 2. Costs for line extension from the project to tap the distribution circuit should be estimated using Section 2.1, above.
- 3. Component 2 assumes Company Substation is already SCADA enabled.
- 4. Estimate does not contain any of the following costs:
  - a. Telecommunication infrastructure
  - b. Relay Coordination Study
  - c. Land Cost
  - d. Environmental Assessment/Environmental Impact Statement
  - e. Project Management
- 5. Substation relay protection requirements have not been identified, so costs are based upon typical line protection relaying requirements.
- 6. All estimates are provided in 2022 dollars.

Hawaii Electric Light Company  
 APPENDIX H - INTERCONNECTION FACILITIES AND COST INFORMATION

**2.4 Telecommunications**

Please refer to Attachment 1 (for Projects greater than 250 kW and less than 1 MW) or Attachment 2 (for Projects 1 MW or greater), of this Appendix H for a single line diagram depicting the required interconnection to the Company’s system. Conceptual design is not intended to cover all interconnection requirements. Final interconnection design will be subject to the results of a technical review.

The communications equipment will require a communications channel(s). Some of the communications channel options include cellular, lease line, licensed radio, fiber, or microwave. The number of communication circuits (primary/backup) and type of communication circuits required will vary depending on the type/size of the project.

The costs below are high level per unit costs for communications requirements in support of the Project. Sections 2.5 and 2.6 provide scenarios of when these options may be utilized. Attachment 3 also provides examples of how to apply these per unit costs.

**2.4.1 Cellular or Lease Line Options**

<b>Component</b>	<b>Description</b>	<b>Cost</b>
1	Cellular or Lease line one-time and recurring costs	will vary based on 3 <sup>rd</sup> party provider
2	Communications Cabinet* with SCADA	\$116,000 / site
3	Communications Cabinet* with SCADA and Relay Protection	\$161,000 / site
4	Communications Enclosure with SCADA (proj. less than 1MW)	\$43,000 / site

\* All projects that require communications will require facilities to store the communications equipment. An example for a communications cabinet is provided but other alternatives can be available upon request.

**Notes:**

1. Cellular or Lease Line:
  - a. Check with Company to understand the current cellular or lease line requirements.
  - b. Communication circuit requirements will be based on applications needed for the project.
  - c. Company can provide communication circuit interconnection requirements and assist with review of circuit order from the 3<sup>rd</sup> party provider as needed.
  - d. Customer to work directly with 3<sup>rd</sup> party provider if a cellular or lease line circuit is needed.
  - e. Cost will be the responsibility of the developer and to be negotiated with the 3<sup>rd</sup> party provider.

Hawaii Electric Light Company  
APPENDIX H - INTERCONNECTION FACILITIES AND COST INFORMATION

2. Communications Cabinet or Enclosure:
  - a. Cabinet used to support company equipment and capable of providing communications circuit for SCADA.
  - b. Communications cabinet cost does not include fiber, microwave, or radio equipment or lease circuits.
  - c. Customer will provide all conduits, foundations, handholes, AC Power, grounding as required per company standards.
  - d. Cost estimates are in 2022 dollars.

**2.4.2 Licensed 900 MHz Radio Option**

<b>Component</b>	<b>Description</b>	<b>Cost</b>
1	Licensed 900 MHz Radio equipment	\$137,000 / link
2	Communications Cabinet with SCADA	\$116,000 / site
3	Communications Cabinet with SCADA and Relay Protection	\$161,000 / site

**Notes:**

1. Licensed 900 MHz Radio:
  - a. This cost will be in addition to the Communication Cabinet cost. The radio equipment will be installed within the Communication Cabinet.
  - b. There is radio line-of-sight clearance between the communication endpoints.
  - c. FCC licensed 900Mhz frequencies are available.
  - d. There is an existing structure/building with space available on the company side to mount the antenna equipment and house the radio equipment.
  - e. The customer will install a structure to mount the antenna equipment on the customers side.
    - i. Customer will provide any conduit required between the Communications Cabinet and antenna mount structure.
  - f. The cost includes 2 each antenna equipment to create a radio link.
  - g. Cost estimates are in 2022 dollars.
2. Communications Cabinet:
  - a. See notes above under 2.4.1 (Cellular or Lease Line Options).

**2.4.3 Fiber Cable Option**

<b>Component</b>	<b>Description</b>	<b>Cost</b>
1	Fiber with overbuild and new construction	\$456,000 / mile
2	Communications Cabinet with SCADA	\$116,000 / site
3	Communications Cabinet with SCADA and Relay Protection	\$161,000 / site

Hawaii Electric Light Company  
APPENDIX H - INTERCONNECTION FACILITIES AND COST INFORMATION

**Notes:**

1. Fiber Cable:
  - a. Accessible 250’ average spans.
  - b. The poles are in good condition and do not need replacing.
  - c. The poles are not overloaded.
  - d. The poles and the attachments are in accordance with NESC 2002 and no work is required to upgrade the poles to current standards.
  - e. Cost estimates are in 2022 dollars.
2. Communications Cabinet:
  - a. See notes above under 2.4.1 (Cellular or Lease Line Options).

**2.4.4 Microwave Option**

<b>Component</b>	<b>Description</b>	<b>Cost</b>
1	Point-To-Point Microwave Link	\$703,000 / link
2	50 Foot Microwave Tower	\$599,000 / tower
3	100 Foot Microwave Tower	\$873,000 / tower
4	Communications Cabinet with SCADA	\$116,000 / site
5	Communications Cabinet with SCADA and Relay Protection	\$161,000 / site

**Notes:**

1. Microwave Link:
  - a. There is radio line-of-sight clearance between the communication endpoints.
  - b. FCC licensed microwave frequencies are available.
  - c. There are existing structures/buildings with space available on both ends to house the radio equipment.
  - d. Telecommunications grounding standards are up-to-date at both sites.
  - e. 48 V DC power with 12-hour battery backup is available.
  - f. This estimate does not include any special site-specific permit/approval activities that may be required including, but not limited to, Neighborhood Board (s), Conservation District Use Application, Environmental Assessment, Shoreline Management Area approval, biological (endangered species or habitat) surveys, and/or cultural (archeological) surveys or the cost of any migration required for approvals to be granted. Proposers should conduct their own due diligence for these costs.
  - g. Space is available at both ends to construct antenna towers or structures that are rated to survive a Saffir-Simpson category 4 hurricane.
  - h. Cost to interconnect to Company’s existing communications network is not included.
  - i. Cost estimates are in 2022 dollars.



Hawaii Electric Light Company  
APPENDIX H - INTERCONNECTION FACILITIES AND COST INFORMATION

2. Microwave Tower

- a. Example costs are provided for two tower options (50 ft or 100ft); other options may be available.
- b. Telecommunications grounding standards are up-to-date.
- c. This estimate does not include any special site-specific permit/approval activities that may be required including, but not limited to, Neighborhood Board (s), Conservation District Use Application, Environmental Assessment, Shoreline Management Area approval, biological (endangered species or habitat) surveys, and/or cultural (archeological) surveys or the cost of any migration required for approvals to be granted. Proposers should conduct their own due diligence for these costs.
- d. Cost estimates are in 2022 dollars.

**2.5 Typical Telecommunications Interconnection Requirements (Projects 250 kW and larger, and less than 1 MW)**

Please refer to Attachment 1 of this Appendix H (for Projects greater than 250 kW and less than 1 MW). Conceptual design is not intended to cover all interconnection requirements. Final interconnection design will be subject to the results of the Detailed Evaluation, Technical Review, or an IRS.

Examples of minimum communications requirements for interconnection projects in this category, which are subject to change based on project specific evaluations, technical reviews, or IRS, are:

1. Primary communications links can consist of cellular, lease line, licensed radio, fiber or microwave.
2. Back-up communications links not required.
3. Additional analog leased telephone lines are required to support revenue meters (cost for this not included in above tables).

**2.6 Typical Telecommunications Interconnection Requirements (Projects 1 MW or greater)**

Please refer to Attachment 2 of this Appendix H (for Projects 1 MW or greater). Conceptual design is not intended to cover all interconnection requirements. Final interconnection design will be subject to the results of the Detailed Evaluation, Technical Review, or an IRS.

Examples of minimum communications requirements for interconnection projects in this category, which are subject to change based on project specific evaluations, technical reviews, or IRS, are:

Hawaii Electric Light Company  
APPENDIX H - INTERCONNECTION FACILITIES AND COST INFORMATION

1. Primary communications links can consist of lease line, licensed radio, fiber or microwave.
2. Back-up communications links can consist of lease line, licensed radio, fiber or microwave.
3. Licensed radio is permitted for projects 3MW or smaller in size only.
4. Back-up communications links are generally optional for projects less than 10 MW. Back-up communications links may be required if the project includes a battery system.
5. Back-up communications links are required for projects greater than or equal to 10 MW.
6. Back-up communications links must be transport diverse until the “last mile” for projects with a battery system greater than 10 MW.
7. Additional analog leased telephone lines are required to support revenue meters (cost for this not included in above tables).

## **2.7 Security System Interconnection Costs**

The Developer shall be responsible to incorporate security components and systems for **their facilities** that consider the Security Guidelines for the Electricity Sector (CIP-014-2): Physical Security, as published by the North American Electric Reliability Corporation (NERC) and that at a minimum adhere to Company’s performance requirements outlined in Company’s Physical Security Strategy for the following four security concepts.

- **Deter:** Deploy visible physical security measures to encourage individuals to seek other, less secure targets.
- **Detect:** Utilize state of the art physical security technologies to detect unauthorized intrusion and provide real-time alerts to monitoring personnel. Detection to include 24/7 monitoring personnel.
- **Delay:** Deploy multiple physical security countermeasures to delay an intruder’s access to assets and provide time for incident assessment and appropriate response.
- **Respond:** Take immediate measures to assess, interrupt, and/or respond to the incident, including notification to Company and the use of contracted patrol personnel and/or the involvement of law enforcement assets to apprehend an intruder.

The Company’s Physical Security Strategy is available upon request after execution of an NDA with the Company.

Facilities will need to meet Tier Three security requirements. These requirements will be subject to final review during the design and engineering phase. Additional information is available upon request after execution of an NDA with the Company.

Hawaii Electric Light Company  
 APPENDIX H - INTERCONNECTION FACILITIES AND COST INFORMATION

Type of Facility	Tier One High Criticality	Tier Two Medium Criticality	Tier Three Lower Criticality
<b>Substation</b>	<ul style="list-style-type: none"> <li>• FLIR or Similar camera perimeter monitoring.</li> <li>• Secondary perimeter intrusion detection system.</li> <li>• Interior Video monitoring system with motion detection.</li> <li>• Gunfire detection/IP intercom public address system.</li> <li>• Electronic card access system for control &amp; microwave houses.</li> <li>• Standard 8' high security fence with 3-strand barbed wire V-top.</li> <li>• Interior mounted 4' high cattle fencing.</li> <li>• LED perimeter lighting.</li> <li>• All gates will be secured using a proprietary padlock system.</li> </ul>	<ul style="list-style-type: none"> <li>• Video monitoring system with motion detection.</li> <li>• Card access on control and microwave houses.</li> <li>• Standard 8' high security fence with 3-strand barbed wire V-top.</li> <li>• Interior mounted 4' high cattle fencing.</li> <li>• All gates will be secured using a proprietary padlock system.</li> </ul>	<ul style="list-style-type: none"> <li>• Standard 8' high security fence with 3-strand barbed wire V-top.</li> <li>• Interior mounted 4' high cattle fencing.</li> <li>• All gates will be secured using a proprietary padlock system.</li> </ul>

**2.8 Project Management Costs**

The costs below indicate additional Project Management expenses:

Component	Description	Cost
1	Projects 1 MW or greater	\$281,217

Attachment 1

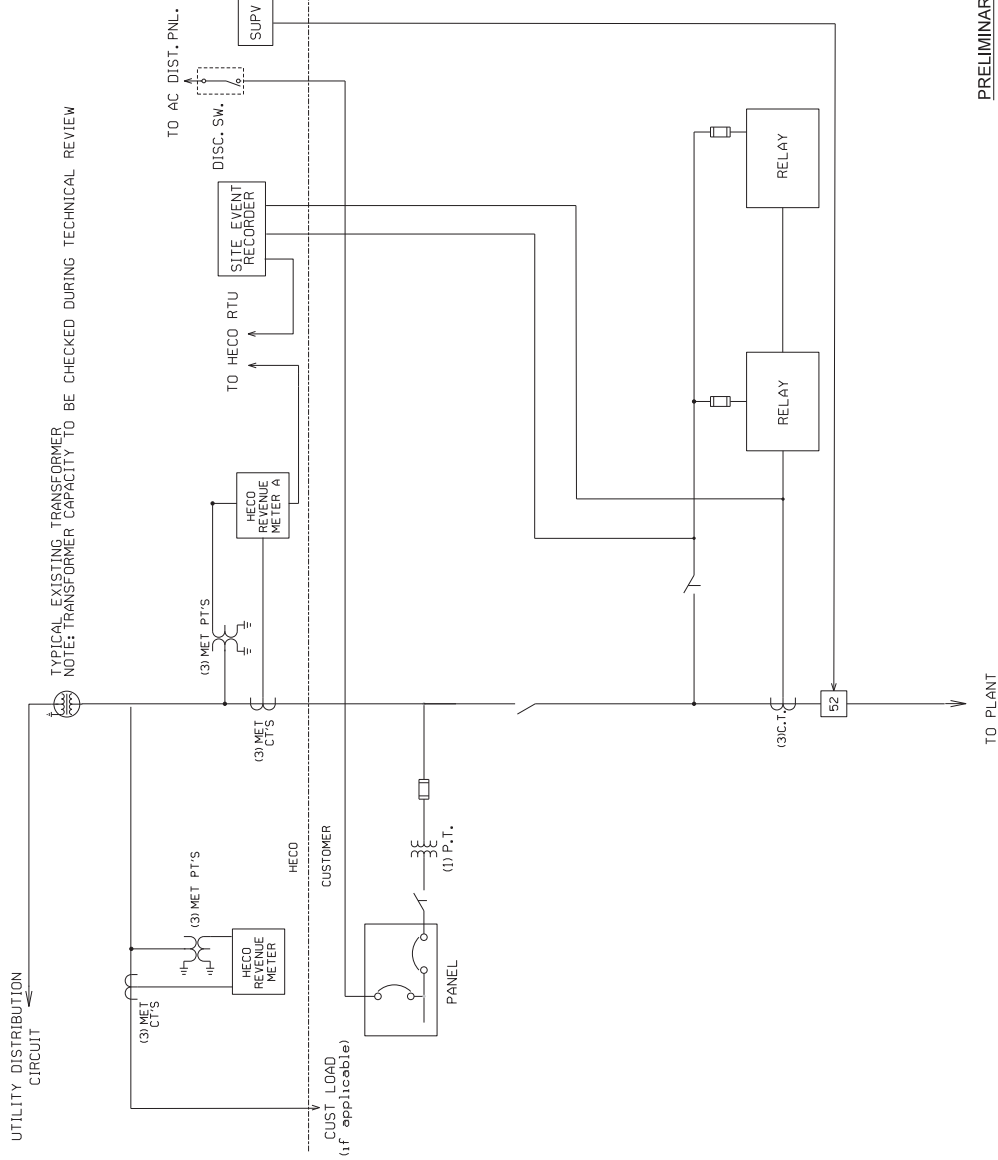

NOTES:

1. 24 HOUR ACCESS:  
ALL HECO EQUIPMENT MUST BE READILY ACCESSIBLE AT ALL TIMES (24 HOURS/7 DAYS) BY HECO PERSONNEL FOR EMERGENCIES, METER READING, INSPECTION, TESTING, AND MAINTENANCE.
2. ANTI-ISLANDING NOTE:  
SHALL FOLLOW REQUIREMENTS AS SET FORTH IN IEEE 1547-2018 FOR UNINTENTIONAL ISLANDING.
3. FOR NEW TRANSFORMERS, TWO (2) SETS OF UNDERGROUND CABLES ARE REQUIRED TO CONNECT THE TRANSFORMER. THE LATERAL EXTENSION TO THE PROJECT SITE SHALL BE PROTECTED BY AN OVER-CURRENT PROTECTIVE DEVICE.

PRELIMINARY  
FOR INITIAL APPLICATION  
NOT TO BE USED  
FOR CONSTRUCTION  
ALSO REFER TO SLD  
DESIGN NOTES

NO.		DATE		REVISIONS		BY	CHKD	APPRD

TYPICAL DISTRIBUTION (250KW AND LARGER TO LESS THAN 1 MW) INTERCONNECTION SINGLE LINE DIAGRAM FOR CBRE

DESIGNED: [ ] SCALE: N/A  
CHECKED: [ ] DATE: 12/23/2018  
APPROVAL: [ ] ENGINEERING DEPARTMENT: HAWAIIAN ELECTRIC CO., LLC.  
DRAWING NUMBER: [ ]

DATE: 12/23/2018  
SCALE: N/A  
ENGINEERING DEPARTMENT: HAWAIIAN ELECTRIC CO., LLC.  
DRAWING NUMBER: [ ]

PROJECT: [ ]  
PREPARED BY: [ ]  
CHECKED BY: [ ]  
DATE: 12/23/2018

**Notes to be added to the Distribution (25 kV and lower) PV/BESS (250kW and larger to less than 1MW) Project Single Line Diagram**

<b>PROPOSED PROJECT NAME:</b>	
<b>PROPOSED PROJECT SIZE:</b>	
<b>CUSTOMER SLD REVISION NUMBER AND DATE:</b>	
<b>COMPANY SLD REVISION NUMBER AND DATE:</b>	
<b>COMPANY SUBSTATION:</b>	
<b>COMPANY DISTRIBUTION CIRCUIT:</b>	
<b>COMPANY DISTRIBUTION CIRCUIT BREAKER #:</b>	

**Planning Notes**

1. If IRS required, by operation procedure(s), the Project shall be paralleled with the Company system only when the \_\_\_\_\_ (Distribution circuit name) XX kV Distribution circuit is in normal operating configuration served via breaker \_\_\_\_\_ (HECO/MECO/HELCO breaker number) at \_\_\_\_\_ (Company substation name) Substation.
  
2. Customer to ensure manual closing of Customer’s main AC kV breaker CB-A (HECO/MECO/HELCO # XXXX) shall be allowed only for hot line (\_\_\_\_\_(Company Distribution circuit) XX kV line-side) and dead bus (Customer-side) unless otherwise allowed by the Company. There shall be no auto reclosing on Customer’s main AC breaker CB-A (HECO/MECO/HELCO # XXXX).

**System Operation Notes**

3. Company load dispatcher shall be enabled to issue the following to the Customer via DNP 3.0, or other Company-approved protocol interface:
  - a. Maximum Power Limit and Power Reference Limit (dispatch) set point control signals. Customer is not allowed to override Company’s curtailment control; and
  
4. The following signals provided by the Customer shall be telemetered to Company load dispatch office:
  - a. Status of Customer’s main XX kV breaker CB-A (HECO/MECO/HELCO # XXXX);
  - b. Distribution voltage (3 phase L-N);
  - c. Facility Power Possible (kW);
  - d. Facility Online/Offline Status;
  - e. Facility output (kW) that is being exported to Company System;
  - f. Facility’s confirmation of a Company control being received and value of that control as implemented.
  
5. The facility equipment should be capable of supporting, at a future date additional telemetry data requested by the Company as applicable:

Attachment 1

- a. Distribution line amps (3 phase), frequency, NET kW, NET kVAR, and NET power factor at point of interconnection. Power factor to be a calculated value;
  - b. PV kW and kVAR output;
  - c. BESS kW and kVAR output/charge;
  - d. Received kWh accumulator, sent kWh accumulator, received kVARh accumulator, Sent kVARh accumulator;
  - e. Plane of Array Solar Irradiance in Watts/m<sup>2</sup>;
  - f. kW output for each inverter;
  - g. Status for each inverter;
  - h. Facility Net Power Possible (kW);
  - i. Volt-Var curve and deadband settings;
  - j. Volt-Var Enabled/Disabled Status;
  - k. Volt-Watt curve and deadband settings;
  - l. Volt-Watt Enabled/Disabled Status;
  - m. Frequency-Watt curve and deadband settings;
  - n. Frequency-Watt Enabled/Disabled Status;
  - o. BESS State of Charge (%);
  - p. BESS Energy remaining (kWh);
  - q. kW set point for each inverter
6. The following occurrences shall initiate separate alarm to Company load dispatch office.
- a. RTU Loss of Communication;
  - b. Violation of Maximum Ramp Rate Upward (Performance Standard); and
  - c. Violation of Maximum Ramp Rate Downward (Performance Standard).
7. Company requires 24 hour access to Company-owned SCADA, communication, and Company-owned relaying and monitoring equipment.
8. Company shall own a high-speed digital fault recorder (DFR) (i.e., Tesla Lite Model) near the point of interconnection, which shall be in continuous service and on a rolling window basis monitoring sub-cycle voltages, currents and harmonics, as well as disturbance events and capable of remote interrogation following an event. Company requires 24 hour access to this equipment. Customer to provide the following hard wired inputs to Company's power quality device:
- a. Status of Customer's main AC breaker CB-A (HECO/MECO/HELCO # XXXX);
  - b. line amps (3 phase); and
  - c. line-to-line voltage (3 phase)

**Telecommunication Notes**

9. Secure and reliable communication is required for the following:
- a. Monitoring and control to/ from Customer's facility;
  - b. Revenue metering for power export and consumption readings (for 1MW facility; and

Attachment 1

c. Phone circuits as required.

10. Customer to provide leased service from Hawaiian Telecom as required. Customer to coordinate with Company for details

**Metering Notes**

11. Customer to design revenue metering facilities in accordance with the requirements in Chapter 4 of the Company's Electric Service Installation Manual.

**Design Notes**

12. Customer to provide a reliable DC source for 12 hour backup period; specific voltage to be determined by Company at a later date.

13. Customer to provide a source of station service power for its facility that will remain available when Customer's main XX kV breaker CB-A (HECO/MECO/HELCO # XXXX) is opened and the facility is separated from Company's system.

14. PTs and CTs for DFR should be the same quality as the PTs and CTs for the protective relaying.

15. Customer to provide raw count (DNP 3.0) for analog points to Company. Customer to provide hardwired dry contact pairs for status points to Company and accept hardwired control points from Company (except for DNP control signals identified in Note 3 and DNP status points identified in Note 5g).

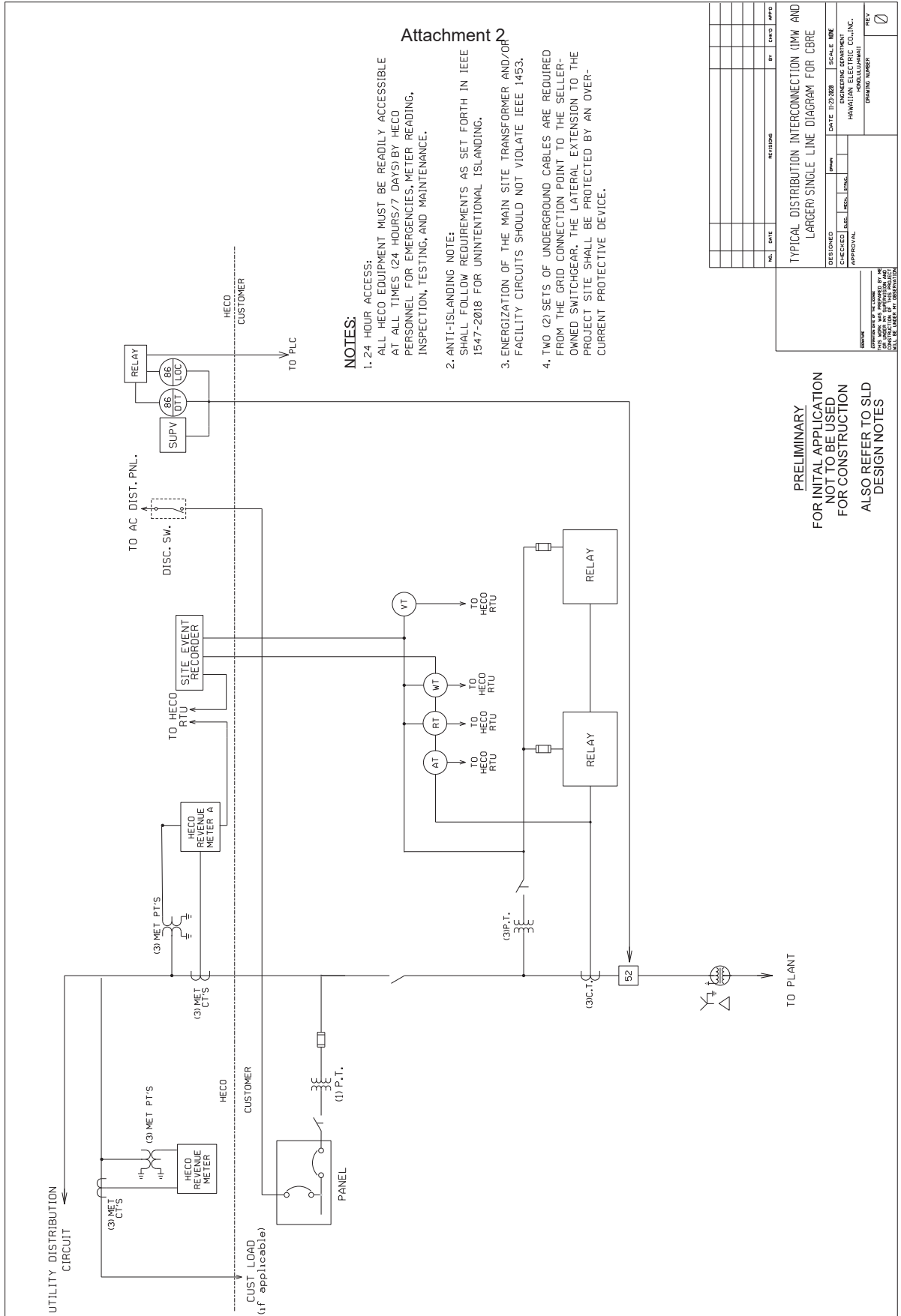

**NOTES:**

1. 24 HOUR ACCESS:  
ALL HECO EQUIPMENT MUST BE READILY ACCESSIBLE AT ALL TIMES (24 HOURS/7 DAYS) BY HECO PERSONNEL FOR EMERGENCIES, METER READING, INSPECTION, TESTING, AND MAINTENANCE.
2. ANTI-ISLANDING NOTE:  
SHALL FOLLOW REQUIREMENTS AS SET FORTH IN IEEE 1547-2018 FOR UNINTENTIONAL ISLANDING.
3. ENERGIZATION OF THE MAIN SITE TRANSFORMER AND/OR FACILITY CIRCUITS SHOULD NOT VIOLATE IEEE 1453.
4. TWO (2) SETS OF UNDERGROUND CABLES ARE REQUIRED FROM THE GRID CONNECTION POINT TO THE SELLER-OWNED SWITCHGEAR. THE LATERAL EXTENSION TO THE PROJECT SITE SHALL BE PROTECTED BY AN OVER-CURRENT PROTECTIVE DEVICE.

**Attachment 2**

NO.	DATE	REVISION	BY	CHKD	APPRD

**PRELIMINARY  
FOR INITIAL APPLICATION  
NOT TO BE USED  
FOR CONSTRUCTION  
ALSO REFER TO SLD  
DESIGN NOTES**

TYPICAL DISTRIBUTION INTERCONNECTION (DMW AND LARGER) SINGLE LINE DIAGRAM FOR CBRE

DESIGNED: \_\_\_\_\_ DATE: 12/2/2023 SCALE: N/A  
 CHECKED: \_\_\_\_\_ DATE: \_\_\_\_\_  
 APPROVAL: \_\_\_\_\_  
 ENGINEERING DEPARTMENT: HAWAIIAN ELECTRIC COMPANY  
 HONOLULU, HAWAII

DRAWING NUMBER: \_\_\_\_\_ REV: 0

DATE: 12/2/2023  
 DRAWN BY: \_\_\_\_\_  
 CHECKED BY: \_\_\_\_\_  
 APPROVED BY: \_\_\_\_\_



**Notes to be added to the Distribution (25 kV and lower) PV/BESS (1 MW and larger) Project Single Line Diagram**

<b>PROPOSED PROJECT NAME:</b>	
<b>PROPOSED PROJECT SIZE:</b>	
<b>CUSTOMER SLD REVISION NUMBER AND DATE:</b>	
<b>COMPANY SLD REVISION NUMBER AND DATE:</b>	
<b>COMPANY SUBSTATION:</b>	
<b>COMPANY DISTRIBUTION CIRCUIT:</b>	
<b>COMPANY DISTRIBUTION CIRCUIT BREAKER #:</b>	

**Planning Notes**

1. If IRS required, by operation procedure(s), the Project shall be paralleled with the Company system only when the \_\_\_\_\_ (Distribution circuit name) XX kV Distribution circuit is in normal operating configuration served via breaker \_\_\_\_\_ (HECO/MECO/HELCO breaker number) at \_\_\_\_\_ (Company substation name) Substation.
2. Upon receipt of direct transfer trip signal from \_\_\_\_\_ (Company substation name) Substation opening of breaker \_\_\_\_\_ (HECO/MECO/HELCO breaker number), trip and block close Customer's main XX kV breaker CB-A (HECO/MECO/HELCO # XXXX) via Company-owned SCADA resettable lockout relay.
3. Upon DTT communication channel failure longer than 6 seconds:
  - a. Company to provide signal to Customer to initiate Customer performed ramp down and tripping of Customer's main XX kV breaker CB-A (HECO/MECO/HELCO # XXXX).
  - b. Company to initiate trip and block close of Customer's main XX kV breaker CB-A (HECO/MECO/HELCO # XXXX) via Company-owned SCADA resettable lockout relay after \_\_\_\_\_ (Project size MW/2 MW per minute ramp down) minutes.
4. Customer to ensure manual closing of Customer's main XX kV breaker CB-A (HECO/MECO/HELCO # XXXX) shall be allowed only for hot line \_\_\_\_\_ (Company Distribution circuit) XX kV line-side) and dead bus (Customer-side) unless otherwise allowed by the Company. There shall be no auto reclosing on Customer's main XX kV breaker CB-A (HECO/MECO/HELCO # XXXX).

**System Operation Notes**

5. Company shall have SCADA trip control over Customer's main XX kV breaker CB-A (HECO/MECO/HELCO # XXXX).
6. Company load dispatcher shall be enabled to issue the following to the Customer via DNP 3.0 interface:
  - a. Maximum Power Limit and Power Reference Limit (dispatch) set point control signals. Customer is not allowed to override Company's curtailment control; and

Attachment 2

- b. Line to line Voltage (analog kV) set point control signal.
7. The following signals provided by the Customer shall be telemetered to Company load dispatch office:
- a. Status of Customer's main **XX kV** breaker CB-A (HECO/MECO/HELCO # XXXX);
  - b. Status of remotely-resettable lockouts;
  - c. Distribution line amps (3 phase), Distribution voltage (3 phase L-N), frequency, NET MW, NET MVAR, and NET power factor at point of interconnection. Power factor to be a calculated value;
  - d. Distribution line amps (B phase), Distribution voltage (A-B phase), NET MW, and NET MVAR at point of interconnection through use of Company approved non-programmable analog transducers. Data to be provided in analog format (+/- 1mA) directly from the analog transducers;
  - e. PV MW and MVAR output;
  - f. BESS MW and MVAR output/charge;
  - g. Received KWh accumulator, sent KWh accumulator, received KVARh accumulator, Sent KVARh accumulator.
  - h. Status Indicating when Maximum Power Limit is in effect;
  - i. Latest received Maximum Power Limit and Power Reference Limit Setpoints;
  - j. EMS Control Status indicating who has control over dispatch and voltage (Local vs Company);
  - k. Voltage Regulator Status – Normal or Alarm (regular On or Off)
  - l. Frequency Response Status – Normal or Alarm (On or Off);
  - m. Latest received voltage set point;
  - n. Wind speed in Miles per Hour and direction;
  - o. Barometric Pressure;
  - p. Temperature in Celsius;
  - q. Solar Irradiance in Watts/m<sup>2</sup>;
  - r. Humidity in Percent;
  - s. KW output for each inverter;
  - t. Status for each inverter (by DNP status);
  - u. Ramp Rate;
  - v. Plant Power Possible (MW);
  - w. Frequency Droop percent and deadband settings;
  - x. BESS State of Charge (%);
  - y. BESS Energy remaining (MWH);
  - z. KW set point for each inverter;
  - aa. Global Horizontal Irradiance on same axis as array (Watts/m<sup>2</sup>);
  - bb. Plane of Array Irradiance on same axis as array (Watts/m<sup>2</sup>); and
  - cc. Back of Panel temperature at array height (Celsius).
8. The following occurrences shall initiate separate alarm to Company load dispatch office.
- a. DTT and RTU Loss of Communication;

Attachment 2

- b. 48VDC and/or 125VDC Charger Trouble. Specific alarms to be determined by Company at a later date;
  - c. Trouble alarm for loss of VDC source(s); and
  - d. Operation of Company-owned SCADA re-settable lockout relays;
  - e. Violation of Maximum Ramp Rate Upward (Performance Standard); and
  - f. Violation of Maximum Ramp Rate Downward (Performance Standard).
9. Company requires 24 hour access to Company-owned SCADA/RTU, communication, and Company-owned relaying and monitoring equipment.
10. Company shall own a high-speed digital fault recorder (DFR) (i.e., Tesla Model No. 4000) near the point of interconnection, which shall be in continuous service and on a rolling window basis monitoring sub-cycle voltages, currents and harmonics, as well as disturbance events and capable of remote interrogation following an event. Company requires 24 hour access to this equipment. Customer to provide the following hard wired inputs to Company's power quality device:
- a. Status of Customer's main XX kV breaker CB-A (HECO/MECO/HELCO # XXXX);
  - b. Status of remotely-resettable lockouts;
  - c. Distribution line amps (3 phase); and
  - d. Distribution line-to-neutral voltage (3 phase)

**Telecommunication Notes**

11. For DTT communication channel failure:
- a. Signal to Customer to initiate Customer performed ramp down and tripping of Customer's main XX kV breaker CB-A (HECO/MECO/HELCO # XXXX) shall be from Company-owned SEL-2411. Company SEL-2411 signal is to be a continuous signal while communication channel is failed.
  - b. Trip and block close of Customer's main XX kV breaker CB-A (HECO/MECO/HELCO # XXXX) shall be performed by Company-owned SEL-2411 via Company-owned SCADA resettable lockout relay.
12. Secure and reliable communication is required for the following:
- a. Direct transfer trip from \_\_\_\_\_ (Company Distribution circuit) XX kV CB \_\_\_\_\_ (HECO/MECO/HELCO breaker number);
  - b. SCADA to/ from Customer's facility;
  - c. Optional back-up SCADA to/from Customer's facility;
  - d. Revenue metering for power export and consumption readings;
  - e. Power quality and fault recording and retrieval; and
  - f. Phone circuits as required.
13. Customer to provide leased service from Hawaiian Telecom as required. Customer to coordinate with Company for details.

Attachment 2

14. All DTT or SCADA loss of comm greater than or equal to 6 seconds shall cause the site to ramp down and trip (applies to both primary and backup).

**Metering Notes**

15. Customer to design revenue metering facilities in accordance with the requirements in Chapter 4 of the Company's Electric Service Installation Manual.

**Design Notes**

16. Customer to provide a reliable DC Source for 12 hour backup period; specific voltage to be determined by Company at a later date.
17. Customer to provide a source of station service power for its facility that will remain available when Customer's main XX kV breaker CB-A (HECO/MECO/HELCO # XXXX) is opened and the facility is separated from Company's system.
18. PTs and CTs for DFR and RTU transducers should be the same quality as the PTs and CTs for the protective relaying.
19. Customer to provide raw count (DNP 3.0) for analog points to Company (except as identified in Note 8d). Customer to provide hardwired dry contact pairs for status points to Company and accept hardwired control points from Company (except for DNP control signals identified in Note 8 and DNP status points identified in Note 8t).

**PROJECT EXAMPLES (HAWAII ISLAND) - APPENDIX H UNIT COST TABLE**

Examples provided for illustrative purposes only and is not binding for actual facility costs.

Estimated costs represent Company costs charged to the Developer.

**Projects 250kW and larger and less than 1MW interconnecting to a distribution circuit****Example 1**

270kW PV system interconnecting to an existing 150KVA transformer. Transformer needs to be replaced. No utility line extension is needed. Developer's secondary cables can be terminated to new transformer. Developer site built per Attachment 1 of this Appendix H (for Projects greater than 250kW and less than 1 MW). No remote sub work since no DTT/Relay work is required for this project size. Developer to provide cellular communications with another provider. Company to install Company-owned equipment in Developer-provided communications enclosure. Developer substation needs to meet Tier 3 security requirements.

Appx H Sec	Description	Quantity	Unit	Unit Price (\$)	Total Cost (\$)
2.1-7	Padmount transformer	1	EA	\$97,000	\$97,000
2.2-1	Company work at Developer site	1	EA	\$442,000	\$442,000
2.4.1-1	Cellular line (by Developer)	1	EA	\$0	\$0
2.4.1-4	Communications Enclosure	1	EA	\$43,000	\$43,000
2.7	Tier 3 Security (by Developer)	1	EA	\$0	\$0
				<b>ESTIMATED TOTAL =</b>	<b>\$582,000</b>

**Example 2**

750kW PV system interconnecting to an existing 12kV UG circuit. The line extension includes 50ft of new 12kV underground (2 feeders). A new transformer is required. Developer to install 12kV civil infrastructure. Developer site built per Attachment 1 of this Appendix H (for Projects greater than 250kW and less than 1 MW). No remote sub work since no DTT/Relay work is required for this project size. Developer to provide a licensed radio for telecommunications. Company to install Company-owned equipment in Developer-provided communications cabinet. Developer substation needs to meet Tier 3 security requirements.

Appx H Sec	Description	Quantity	Unit	Unit Price (\$)	Total Cost (\$)
2.1-5	New 12kV UG	50	FT	\$456	\$22,794
2.1-7	Padmount transformer	1	EA	\$97,000	\$97,000
	12kV civil infrastructure (by Developer)	1	LS	\$0	\$0
2.3-1	Company work at Developer site	1	EA	\$442,000	\$442,000
2.4.2-1	Licensed Radio	1	EA	\$137,000	\$137,000
2.4.2-2	Communications Cabinet w/SCADA	1	EA	\$116,000	\$116,000
2.7	Tier 3 Security (by Developer)	1	EA	\$0	\$0
				<b>ESTIMATED TOTAL =</b>	<b>\$814,794</b>

**Projects 1MW or greater interconnecting to a distribution circuit****Example 3**

3MW PV system interconnecting to an existing overhead 12kV circuit. The line extension includes underbuilding approximately 300ft of 12kV overhead lines on existing poles and 100ft of underground line (2 sets of cables). The line extension terminates at a customer-owned metering switchgear. Developer to install 12kV civil infrastructure. Developer site built per Attachment 2 of this Appendix H (for Projects 1MW or greater). Remote substation work is required at one (1) site for DTT/Relay work. Developer to install 12kV civil infrastructure. Developer to provide leased line telecommunications with another provider. Company to install Company-owned equipment in Developer-provided communications cabinet. Developer substation needs to meet Tier 3 security requirements.

Appx H Sec	Description	Quantity	Unit	Unit Price (\$)	Total Cost (\$)
2.1-3	12kV underbuild on existing line	300	FT	\$162	\$48,693
2.1-5	New 12kV UG	100	FT	\$456	\$45,587
2.1-6	12kV double riser	1	EA	\$48,000	\$48,000
	12kV civil infrastructure (by Developer)	1	LS	\$0	\$0
2.3-1	Company work at Developer site	1	EA	\$480,000	\$480,000
2.3-2	DTT/Relay	1	SITE	\$356,000	\$356,000
2.4.1-1	Leased line (by Developer)	1	EA	\$0	\$0
2.4.1-3	Communications Cabinet w/ SCADA and relay protection	1	EA	\$161,000	\$161,000
2.7	Tier 3 Security (by Developer)	1	EA	\$0	\$0
2.8-1	Project Management	1	LS	\$281,000	\$281,000
				<b>ESTIMATED TOTAL =</b>	<b>\$1,420,280</b>

**Example 4**

2MW PV system interconnecting to an existing underground 12kV circuit. The line extension includes approximately 450ft of underground cables (2 sets of cables). Company-owned switchgear required before a Developer-owned metering switchgear. The Company line extension terminates at the customer-owned metering switchgear. Developer to install 12kV civil infrastructure. Developer site built per Attachment 2 of this Appendix H (for Projects 1MW or greater). Remote substation work is required at one (1) site for DTT/Relay work. Developer to provide leased line telecommunications with another provider. Company to install Company-owned equipment in Developer-provided communications cabinet. Developer substation needs to meet Tier 3 security requirements.

Appx H Sec	Description	Quantity	Unit	Unit Price (\$)	Total Cost (\$)
2.1-4	New 12kV UG	450	FT	\$456	\$205,142
2.1-7	Switchgear	1	EA	\$229,000	\$229,000
	12kV civil infrastructure (by Developer)	1	LS	\$0	\$0
2.3-1	Company work at Developer site	1	EA	\$480,000	\$480,000
2.3-2	DTT/Relay	1	SITE	\$356,000	\$356,000
2.4.1-1	Leased line (by Developer)	1	EA	\$0	\$0

2.4.1-3	Communications Cabinet w/ SCADA and relay protection	1	EA	\$161,000	\$161,000
2.7	Tier 3 Security (by Developer)	1	EA	\$0	\$0
2.8-1	Project Management	1	LS	\$281,000	\$281,000
			<b>ESTIMATED TOTAL =</b>		<b>\$1,712,142</b>

**DRAFT**  
**REQUEST FOR PROPOSALS**  
**FOR**  
**COMMUNITY-BASED RENEWABLE ENERGY TRANCHE 1**  
**ISLAND OF HAWAI‘I**

DECEMBER 1, 2020

Docket No. 2015-0389

*Appendix I – Rule 19 Tariff*

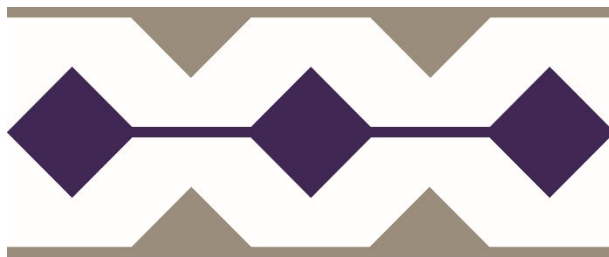

**Hawai‘i  
Electric  
Light**



## RULE NO. 19

## Interconnection and Transmission Upgrades

## A. GENERAL

## 1. Definitions

- a. "Betterment" means and includes any upgrading to a facility made solely for the benefit of and at the election of the Company, not attributable to the interconnection requirements. The Betterment includes any provisions for future expansion which cannot be charged to replacement. It also includes any related system work beyond that required for interconnection. If an existing facility is replaced with one of greater functional capacity or capability, the difference between the upgraded facility and a replacement facility of equivalent functional capacity is considered Betterment. It does not mean the substitution of a replacement facility for an existing facility, that is, an underground facility for an overhead facility, unless otherwise provided for in the RFP.

Example 1: A substation with a three breaker scheme is required to connect the Generating Facility to the grid. If the Company installs a substation with a six breaker ring bus scheme, the difference between installing a substation with a three breaker scheme and one with a six breaker scheme would be the Betterment.

Example 2: A transmission line needs to be upgraded to accommodate a new Generating Facility. The existing line is designed to withstand a 56 mph wind speed. The project includes upgrading the facilities to withstand a 100 mph wind speed. The increase in the design to the 100 mph wind speed criteria would be the Betterment.

Example 3: A transmission line needs to be upgraded to accommodate a new Generating Facility. In response to the Company's application to upgrade the line, the Commission orders that the line be placed underground. The cost difference between the overhead upgrade and the installation of the underground facilities would not be considered Betterment.

- b. "Company's Dispatch" means the Company's sole and absolute right to control, from moment to moment, through Supervisory Control, or otherwise, and in accordance with good engineering and operating practices in the electric utility industry, the rate of delivery of energy offered by the bidder to the Company.
- c. "Company's System" means the electric system owned and operated by the Company (to include any non-utility owned facilities) consisting of power plants, transmission and distribution lines, and related equipment for the production and delivery of electric power to the public.

HAWAII ELECTRIC LIGHT COMPANY, INC.

## RULE NO. 19 - Continued

## Interconnection and Transmission Upgrades

- d. "Distribution System" means all electrical wires, equipment, and other facilities at the distribution voltage levels (such as 25kV, 12kV, or 4kV) owned or provided by the Company, through which the Company provides electrical service to its customers.
- e. "Framework" means the Framework for Competitive Bidding dated December 8, 2006, adopted by the Commission in Docket No. 03-0372, Decision and Order No. 23121, which provides the mechanism for acquiring a future energy generation resource or a block of generation resources by the Company.
- f. "Generating Facility" means a bidder or utility-owned electrical energy generation resource that is interconnected to the Company electrical grid.
- g. "Grid Connection Point" means the point at which Interconnection Facilities connect to the Company's System, normally the Company's transmission grid. Facilities from the Generating Facility to the Grid Connection Point shall be considered Interconnection Facilities (see examples given in Attachment A). The Grid Connection Point will be identified in the IRS.
- h. "Interconnection Agreement" means a contract with the bidder that specifies the terms and conditions under which Interconnection Facilities (and, in some cases, certain System Upgrades) will be designed, installed, paid for, owned, operated and/or maintained. In some instances, such terms and conditions may be included in the PPA with a bidder, instead of in a separate Interconnection Agreement.
- i. "Interconnection Facilities" means the equipment and devices required to permit a Generating Facility to operate in parallel with and deliver electric energy to Company's System and provide reliable and safe operation of, and power quality on, the Company's System (in accordance with applicable provisions of the Commission's General Order No. 7, Company tariffs, operational practices and planning criteria), such as, but not limited to, transmission and distribution lines, transformers, switches, and circuit breakers.

Example 1: A wind farm facility constructed on a neighbor island (e.g. Molokai) that exports to the Company the energy it produces would be required to install undersea transmission lines to interconnect the Generating Facility to the Company's System. The undersea transmission lines and related facilities would be considered Interconnection Facilities.

HAWAII ELECTRIC LIGHT COMPANY, INC.

## RULE NO. 19 - Continued

## Interconnection and Transmission Upgrades

Example 2: A proposed Generating Facility is remotely located in a region of the island where there are no existing Transmission System facilities. In this case, if the size of the Generating Facility requires that it be tied to the existing Transmission System, the new Transmission System facilities (i.e. all electrical wires, equipment, and other facilities at the transmission voltage level) constructed from the Generating Facility to the Company's existing Transmission System facilities would be considered Interconnection Facilities.

- j. "Interconnection Requirements Study (IRS)" means a study, performed in accordance with the terms of the IRS Letter Agreement and with the applicable terms of the RFP and any resulting PPA, to identify the Interconnection Facilities, System Upgrades and other system requirements and all associated costs to integrate the proposed Generating Facility with the Company's System, and includes a detailed steady-state and a dynamic analysis. The IRS is conducted by the Company or its consultant and the bidder is responsible for the cost of conducting the IRS.
- k. "Interconnection Requirements Study Letter Agreement (IRS Letter Agreement)" means the letter agreement and any written, signed amendments thereto, between the Company and the bidder that describes the scope, schedule, and payment arrangements for the IRS.
- l. "IRP" means an electric utility's Integrated Resource Plan that has been submitted to the Commission for review and approval in the utility's IRP proceeding, in accordance with the Commission's IRP Framework.
- m. "IRP Framework" means the Commission's Framework for Integrated Resource Planning, dated May 22, 1992, as amended by In re Public Util. Comm'n, Docket No. 05-0075, Decision and Order No. 22490, filed on May 26, 2006.
- n. "Point of Interconnection" means the point of delivery of Energy and/or Capacity supplied by the bidder to the Company, where the facilities owned by the bidder interconnect with the facilities owned or to be owned by the Company. The bidder shall own and maintain the facilities from the Generating Facility to the Point of Interconnection. The Company shall own and maintain the facilities from the Point of Interconnection to the Company's System (see examples given in Attachment A). The Point of Interconnection will be identified in the IRS.
- o. "PPA" means a power purchase agreement or contract by the Company to purchase firm capacity, energy, or both.

HAWAII ELECTRIC LIGHT COMPANY, INC.

## RULE NO. 19 - Continued

## Interconnection and Transmission Upgrades

- p. "Renewable Energy Facility" means a Generating Facility that generates electricity using renewable energy as the source.
- q. "RFP" means a written request for proposal issued by the Company to solicit bids from interested third-parties, and where applicable from the Company or its affiliate, to supply a future generation resource or a block of generation resources to the Company pursuant to a competitive bidding process.
- r. "Subtransmission System" means all electrical wires, equipment, and other facilities at the subtransmission voltage levels (such as 46kV, 35kV, or 23kV) owned or provided by the Company, through which the utility provides electrical service to its customers.
- s. "Supervisory Control" means remote monitoring and/or control of a Generating Facility's power output and interrupting device status by means of a communication channel that is acceptable to the Company. For Generating Facilities intending to export power with an aggregate export capacity greater than 250kW, computerized supervisory control may be required to ensure the safety of working personnel and prompt response to system abnormalities in case of islanding of the Generating Facility. The Company shall determine the need for supervisory control based upon the results of the initial technical screening and/or IRS. Supervisory control shall include at a minimum monitoring of: (a) gross generation by the Generating Facility; (b) feedback of Watts, Vars, WattHours, current and voltage; (c) Vars furnished by the utility; and (d) status of the interrupting device. In addition, the supervisory control will allow the Company to trip the interrupting device during emergency conditions. Monitoring will be performed by system dispatchers or operators at the Company's control center.
- t. "System Benefit" means a material increase in power flow capability or in the reliability of the Company's electrical system from a system-wide perspective.
- u. "System Upgrades" means improvements made to the Company's System, other than the Interconnection Facilities, required to provide reliable and safe operation of, and power quality on, the Company's System (in accordance with applicable provisions of the Commission's General Order No. 7, Company tariffs, operational practices and planning criteria) when the Generation Facility is interconnected with the Company's System (see Attachment A). Such improvements may include, but are not limited to, new transmission or distribution lines, reconstruction or reconductoring of existing lines, circuit breakers, switches, transformers, buses, protective devices, communications, and substation equipment and facilities.

HAWAII ELECTRIC LIGHT COMPANY, INC.

## RULE NO. 19 - Continued

## Interconnection and Transmission Upgrades

- v. "Transmission System" means all electrical wires, equipment, and other facilities at the transmission voltage levels (such as 138kV or 69kV) owned or provided by the utility, through which the utility provides electrical service to its customers.

## 2. Application of Tariff

This Tariff shall apply to an RFP issued pursuant to the Framework and Interconnection Requirement Studies arising from the RFP process. In the event that there is a conflict between any provision of this Tariff and that of an RFP issued pursuant to the Framework and reviewed by the Commission in accordance with Sections III.B.2 and IV.B.6.e. of the Framework, the provisions of the RFP shall prevail. The terms and conditions established in a PPA arising from the RFP and approved by the Commission shall ultimately control over the requirements and terms of both this Tariff and the RFP.

## 3. Independent Observer

As established in the Framework, the duties and responsibilities of an Independent Observer (IO) include, among other duties and responsibilities, reviewing and monitoring the Company's communications, methods, and implementation of this Tariff, the RFP and related IRS processes.

## B. INTERCONNECTION STUDY PROCESS FOR COMPETITIVE BIDDING

## 1. RFP Package Data -- available to all prospective bidders.

RFP packages issued by the Company shall contain general and regional system information to provide prospective bidders with high level guidance relating to the Company's existing transmission infrastructure. For example, RFP packages may include information in the form of an island map with areas of the Transmission System identified that are at or near their loading limits to provide high level guidance to bidders on areas of the island with transmission constraints. These constraints may include "load pockets", which are load-driven transmission constraints as well as areas of generation-driven transmission constraints. Because transmission impacts are to a large extent specific to the characteristics of supply-side proposals, definitive transmission information cannot be provided in these maps. Detailed geographic maps of the transmission system may not be part of this information due to security concerns. Rather, a map of the island with areas of the map shaded to identify areas (rather than circuits) of transmission constraints, may be provided.

HAWAII ELECTRIC LIGHT COMPANY, INC.

## RULE NO. 19 - Continued

## Interconnection and Transmission Upgrades

In addition, the RFP shall include applicable transmission planning criteria that will be used in the determination of interconnection requirements and potential Transmission System impacts. The information in the bid package will provide bidders with information (a) that should help in the selection of the proposed project's characteristics, including project site, project size, and project mode of operation, and (b) to estimate the interconnection requirements associated with their Generating Facilities and the opportunity to reflect the costs of the interconnection requirements in their bids.

2. Information Requests During Bidding Process - available to all prospective bidders.

During the bidding process, if a prospective bidder requires clarification or additional technical or operational information pertaining to the Company's System, a written request with specific questions may be submitted to the Company in accordance with the requirements set forth in the RFP. The written request, specific questions, and written Company response will be provided to all bidders.

3. RFP Requirements and Threshold Criteria Screening - evaluation performed on all bids received

Each bid received will be reviewed to ensure that it satisfies all of the RFP and threshold criteria requirements. The Company will determine whether each bid conforms to the specified RFP requirements and meets the minimum threshold criteria. Applicable performance standards may be part of the threshold criteria. These performance standards may vary depending upon factors such as the size of the generating resource(s) being acquired in the RFP, the Company's ability to dispatch the Generating Facility, the operational status (e.g., as-available vs. firm) of the Generating Facility, and the fuel type of the Generating Facility (e.g., run-of-the-river hydro may have different performance standards from wind power).

4. High Level Evaluation -- performed on all bids that pass threshold screening in RFP process
  - a. All bids which pass the threshold screening in the RFP process will undergo a high level evaluation consistent with the requirements identified in the RFP, which will focus primarily on basic steady-state analyses (e.g., identifying thermal line impacts, voltage impacts, and any obvious "fatal flaws").

HAWAII ELECTRIC LIGHT COMPANY, INC.

## RULE NO. 19 - Continued

## Interconnection and Transmission Upgrades

- b. For each bid, a high level estimate of the costs of Interconnection Facilities and required System Upgrades will be developed based solely on the high level evaluation identified in Section B.4.a. of this Tariff and on unitized cost estimates (e.g., \$/mile for 138kV line, \$/transformer).
  - c. Results of the high level evaluation and high level estimate of the costs of Interconnection Facilities and required System Upgrades will be factored into the determination of which bids make the short list based on the requirements specified in the RFP.
  - d. Basic curtailment analysis of the proposed Generating Facility and related impacts to operations of existing Generating Facilities may also be factored into the determination of which bids make the short list based on the requirements specified in the RFP.
5. Full Interconnection Requirements Study - performed only on short list bids.
- a. An IRS shall be performed only for bid(s) that have met the RFP requirements, passed the threshold criteria, and made the short list, or as otherwise specified in the RFP.
  - b. An IRS would be performed either serially starting with the bid evaluated as the most competitive at the point of the evaluation process, then proceeding to the next most competitive bid on the short list or in parallel on all or some of the short list bidders simultaneously. The determination of whether or not IRS work is to be performed serially, in parallel, or a combination of the two will be based upon factors such as resource availability, number of short list bids, RFP schedule, and relative competitiveness of one bid to others, and the availability of all information and data from bidders necessary to perform the IRS work
  - c. The Company may if practicable "bundle" IRS work for multiple short list bids into a single IRS if the bids are, among other factors, technically, operationally and geographically (e.g., size, location, technology, timing, operating characteristics, etc.) identical or sufficiently similar to each other.
  - d. The results of the IRS, including identified Interconnection Facilities, System Upgrades, Point of Interconnection, and Grid Connection Point, will be provided to the bidder.
  - e. Bidders shall be responsible for incorporating the costs of their Interconnection Facilities into their bids. The RFP may provide bidders with an opportunity to revise their pricing proposals under certain circumstances. Any pricing change, if permitted under the terms of the RFP, will prompt a re-evaluation of short list bidders in the selection of the winning bid as provided for in the RFP.

HAWAII ELECTRIC LIGHT COMPANY, INC.

## RULE NO. 19 - Continued

## Interconnection and Transmission Upgrades

- f. The Company may perform the analyses included in the IRS, or the IRS or parts of the IRS may be contracted to an outside consultant specializing in such analyses for complex situations or in situations where the Company does not have available resources to conduct the analyses in a time frame agreeable to the Company.
  - g. The scope and cost of the IRS will depend on the complexity of the Company's System and Generating Facility that must be modeled, and the degree to which the Generating Facility will affect the Company's System.
  - h. The bidder will be responsible for the cost of the IRS (or such lesser amount as the Company may specify to facilitate the processing of interconnection requests for similarly situated facilities) to be performed in order to evaluate the impacts of the Generating Facility's interconnection to the Company's System.
- C. INTERCONNECTION COST AND SYSTEM UPGRADE COST ALLOCATION FOR COMPETITIVE BIDDING
- 1. The bidder shall be responsible for the cost of Interconnection Facilities and shall be responsible for the installation and maintenance of Interconnection Facilities from the Generating Facility to the Point of Interconnection, unless otherwise specified in the RFP.
  - 2. Interconnection Facilities from the Generating Facility to the Point of Interconnection shall be built by the bidder, unless the Company agrees otherwise.
  - 3. Interconnection Facilities from the Point of Interconnection to the Grid Connection Point shall be built by the Company and paid for by the bidder, unless the Company agrees or determines otherwise. The Company may elect to include Betterments to Interconnection Facilities from the Point of Interconnection to the Grid Connection Point, and such Betterments shall be paid for by the Company. The cost of Betterments to such Interconnection Facilities will not be considered in the bid evaluations. The bidder shall acquire the necessary land and easements for Interconnection Facilities from the Point of Interconnection to the Grid Connection Point, unless the Company agrees otherwise. Interconnection Facilities from the Point of Interconnection to the Grid Connection Point, if built by the bidder, shall be transferred to the Company upon completion, along with the necessary land rights and easements.

HAWAII ELECTRIC LIGHT COMPANY, INC.



RULE NO. 19 - Continued

Interconnection and Transmission Upgrades

4. The Company shall install and maintain the identified System Upgrades arising from the interconnection of the Generating Facility and shall be responsible for the cost of such System Upgrades.
  - a. The Company's cost for System Upgrades will be considered as a factor in the bid evaluations.
  - b. The degree to which the System Upgrades provide System Benefits and/or Betterments will be considered in the bid evaluations.
5. Standards and Interconnection Agreements
  - a. Interconnection Facilities and System Upgrades owned or to be owned by the Company shall be constructed in accordance with the Company's applicable standards and in accordance with the PPA or the Interconnection Agreement, if there is a separate Interconnection Agreement.
  - b. Generating Facilities and Interconnection Facilities owned by the bidder shall be constructed in accordance with applicable State and County code requirements and in accordance with the PPA or the Interconnection Agreement, if there is a separate Interconnection Agreement.
  - c. The bidder's Generating Facility may be interconnected and operated in parallel with the Company's System in accordance with the terms and conditions of the PPA between the Company and the bidder, and/or the terms and conditions of an Interconnection Agreement between the Company and the bidder, if there is a separate Interconnection Agreement.
  - d. The bidder will be required to furnish, install, operate, and maintain suitable and sufficient equipment, to maintain adequate records, and to follow such operating procedures, as may be specified by the Company to protect the Company's System from damage resulting from the parallel operation of the Seller's Facility, including the equipment, records and operating procedures more fully described in the PPA and/or Interconnection Agreement, if there is a separate Interconnection Agreement.
  - e. Interconnection Facilities shall be designed, installed operated and maintained in accordance with good interconnection practice. The objectives of good interconnection practice include, but are not limited to,
    1. Safety - To protect the safety of utility personnel, utility customers, and the public.

HAWAII ELECTRIC LIGHT COMPANY, INC.

RULE NO. 19 - Continued

Interconnection and Transmission Upgrades

2. Reliability - To maintain the reliability of the utility system for all utility customers.
  3. Power Quality - To provide for acceptable power quality and voltage regulation on the utility system and for all utility customers.
  4. Restoration - To facilitate restoration of power on the utility system.
  5. Protect Utility and Customer Equipment - To protect utility and customer equipment during steady state and faulted system operating conditions.
  6. Protect Generating Facilities - To protect generating facilities from operation of utility protective and voltage regulation equipment.
  7. Utility System Overcurrent Devices - To maintain proper operation of the utility system's overcurrent protection equipment.
  8. Utility System Operating Efficiency - To ensure operation at appropriate power factors and minimize system losses.
- f. The bidder shall obtain, at its expense, any and all authorizations, approvals, permits, and licenses required for the construction and operation of its Generating Facility and the interconnection of its Generating Facility with the Company's System, including but not limited to environmental permits, building permits, rights of way, or easements.
  - g. Where any Company-owned Interconnection Facilities are to be located on the site of the bidder's Generating Facility, the bidder shall provide, at no expense to the Company, a location and access acceptable to the Company for all such facilities.
6. Renewable Energy Facilities
- a. In its IRP process, the Company may propose System Upgrades, to be paid for, owned and maintained by the utility, to encourage the development of Renewable Energy Facilities.
  - b. In its IRP process, the Company may propose to pay for Interconnection Facilities between the Point of Interconnection and the Grid Connection Point, in order to encourage the development of Renewable Energy Facilities.

HAWAII ELECTRIC LIGHT COMPANY, INC.

RULE NO. 19 - Continued

Interconnection and Transmission Upgrades

Attachment A

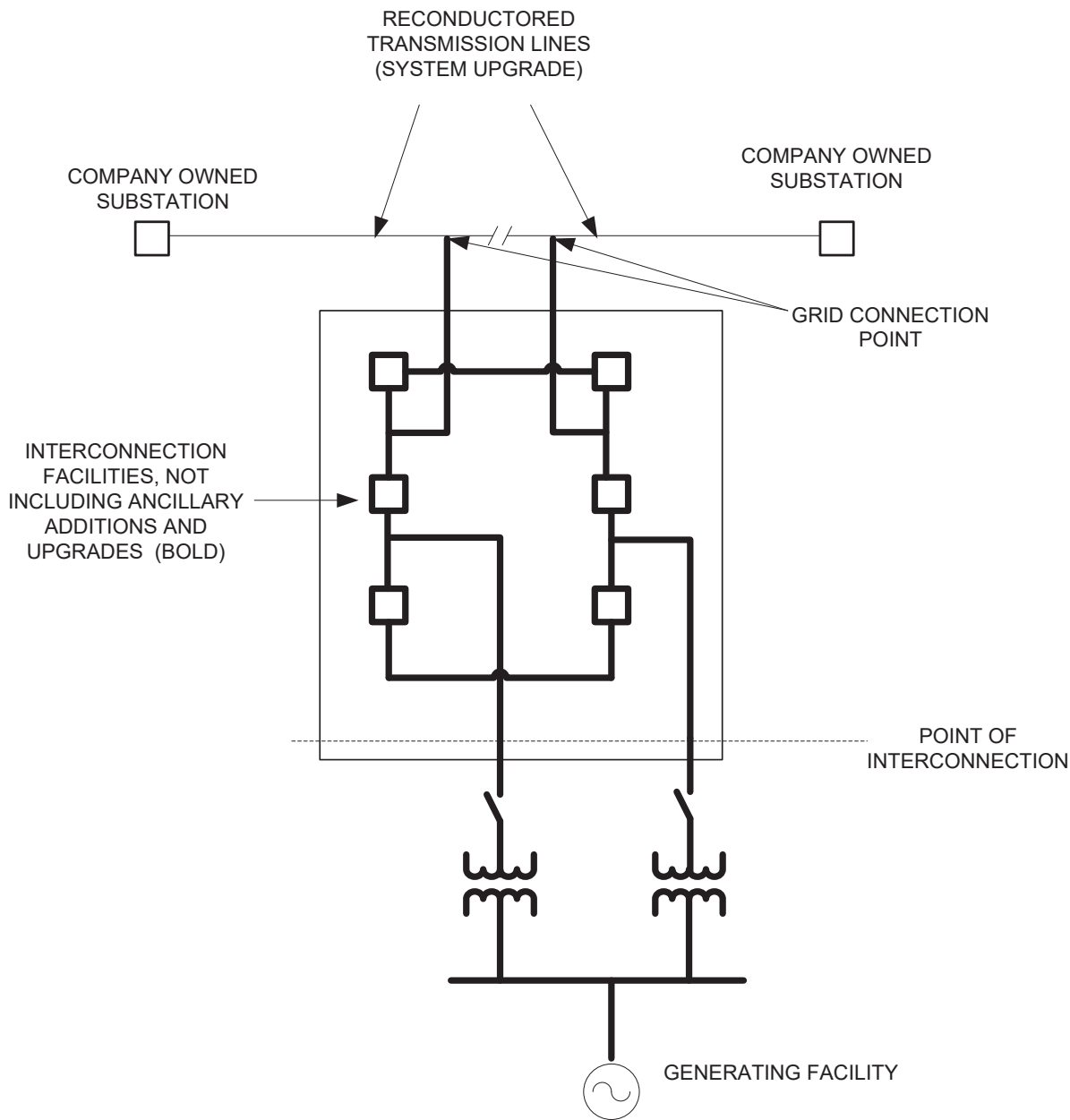

HAWAII ELECTRIC LIGHT COMPANY, INC.

**DRAFT**

**REQUEST FOR PROPOSALS**

**FOR**

**COMMUNITY-BASED RENEWABLE ENERGY TRANCHE 1**

**ISLAND OF HAWAI‘I**

DECEMBER 1, 2020

Docket No. 2015-0389

*Appendix J – Rule 29 Tariff*

**[NOTE: Please refer to Exhibit 3 of the September 8, 2020 filing for the proposed Hawai‘i Electric Light Rule No. 29 CBRE Phase 2 as updated in Exhibit 3 of this December 1, 2020 filing.]**

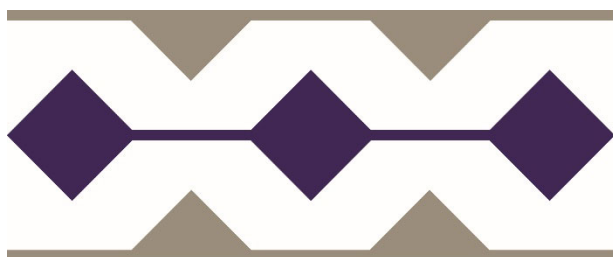

**Hawai‘i  
Electric  
Light**

**DRAFT**

**REQUEST FOR PROPOSALS**

**FOR**

**COMMUNITY-BASED RENEWABLE ENERGY TRANCHE 1**

**ISLAND OF HAWAI‘I**

DECEMBER 1, 2020

Docket No. 2015-0389

*Appendix K – Model PV Large RDG PPA*

**[NOTE: Please refer to Exhibit 12 of this December 1, 2020 filing  
for the Model PV Large RDG PPA.]**



**Hawai‘i  
Electric  
Light**

**DRAFT**

**REQUEST FOR PROPOSALS**

**FOR**

**COMMUNITY-BASED RENEWABLE ENERGY TRANCHE 1**

**ISLAND OF HAWAI‘I**

DECEMBER 1, 2020

Docket No. 2015-0389

*Appendix L – Model PV Mid-Tier Standard Form  
Contract RDG PPA (250kW to 2.5 MW)*

**[NOTE: Please refer to Exhibit 8 of this December 1, 2020 filing  
for the Model PV Mid-Tier Standard Form Contract RDG PPA.]**

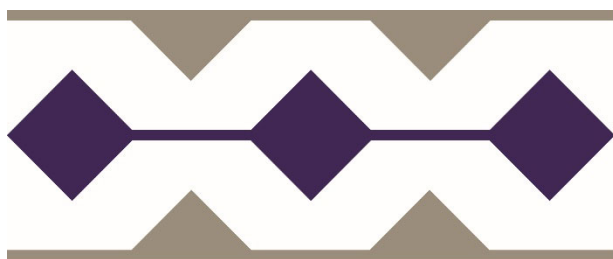

**Hawai'i  
Electric  
Light**

**DRAFT**

**REQUEST FOR PROPOSALS**

**FOR**

**COMMUNITY-BASED RENEWABLE ENERGY TRANCHE 1**

**ISLAND OF HAWAI‘I**

DECEMBER 1, 2020

Docket No. 2015-0389

*Appendix M – Model Wind Large RDG PPA*

**[NOTE: Please refer to Exhibit 14 of this December 1, 2020 filing  
for the proposed Model Wind Large RDG PPA.]**

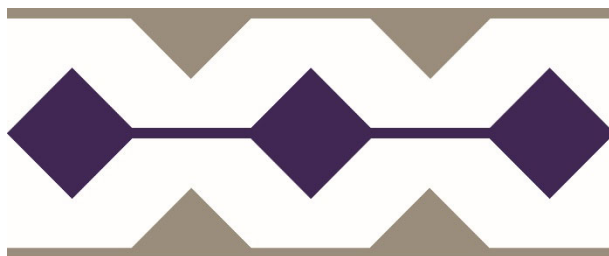

**Hawai‘i  
Electric  
Light**

**DRAFT**

**REQUEST FOR PROPOSALS**

**FOR**

**COMMUNITY-BASED RENEWABLE ENERGY TRANCHE 1**

**ISLAND OF HAWAI‘I**

DECEMBER 1, 2020

Docket No. 2015-0389

*Appendix N – Model Wind Mid-Tier Standard Form  
Contract RDG PPA (250kW to 2.5 MW)*

**[NOTE: Please refer to Exhibit 10 of this December 1, 2020 filing  
for the Model Wind Mid-Tier Standard Form Contract RDG PPA.]**

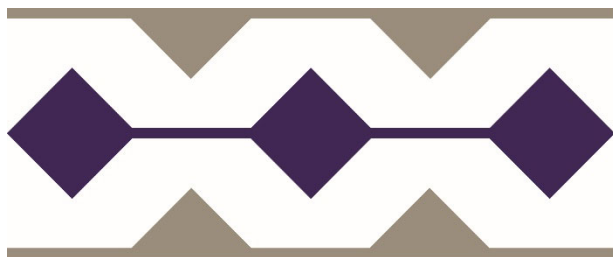

**Hawai‘i  
Electric  
Light**



**DRAFT**

**REQUEST FOR PROPOSALS**

**FOR**

**COMMUNITY-BASED RENEWABLE ENERGY TRANCHE 1**

**FOR**

**ISLAND OF HAWAI‘I**

DECEMBER 1, 2020

Docket No. 2015-0389

*Appendix O – Grid Needs Assessment*



**Hawai‘i  
Electric  
Light**

This Appendix provides the definitions for the grid services considered in the CBRE RFPs and placeholder charts for the grid needs and their relative values. The grid services were defined as part of the Integrated Grid Planning (“IGP”) Solution Evaluation & Optimization Working Group (“SEOWG”) activities. Bidders may use the information provided in this appendix to understand the grid needs in order to structure their proposals to provide the most value to the Company.

Grid Service Definitions

The following grid services are used to identify the grid needs. The projected hourly annual energy potential production profile of the Facility for the provided RFP NEP Projection will be used to inform the capability of the project to provide each of the grid services.

Table 1 Grid Service Definitions

<b>Grid Service</b>	<b>Definition</b>
Energy	A continuous, controllable, and predictable supply of megawatt-hours to serve system load needs in response to Company Dispatch. <sup>1</sup>
Regulating Reserves	A reserve capacity provided by generating and load resources to allow continuous energy balance over the next 1 minute and 20 to 30-minute time interval due to the variability in renewable resources and load that can be called upon in response to Company Dispatch
Fast Frequency Response (FFR1)	An autonomous and predictable capacity to limit the frequency drop resulting from a frequency disturbance
<b>Distribution Capacity</b>	A supply and/or a load modifying service that DERs provide as required via the dispatch of power output for generators and electric storage, and/or reduction in load that is capable of reliably and consistently reducing net loading on desired distribution infrastructure in response to Company Dispatch
<b>Distribution Reliability</b>	A load modifying or supply service capable of improving local distribution reliability under abnormal conditions in response to Company Dispatch

Grid Needs

---

<sup>1</sup> “Company Dispatch” as defined in the PPA and SFC means Company's right, through supervisory equipment or otherwise, to direct or control both the capacity and the energy output of the Facility from its minimum output rating to its maximum output rating consistent with this Agreement (including, without limitation, Good Engineering and Operating Practices and the requirements set forth in Section 3 (Performance Standards) of Attachment B (Facility Owned by Subscriber Organization to this Agreement)), which dispatch shall include real power, reactive power, voltage, frequency, the determination to cycle a unit off-line or to restart a unit, the droop control setting, the ramp rate setting, and other characteristics of such electric energy output whose parameters are normally controlled or accounted for in a utility dispatching system.

The charts below describe the seasonal and annual hourly need for the services in Table 1.

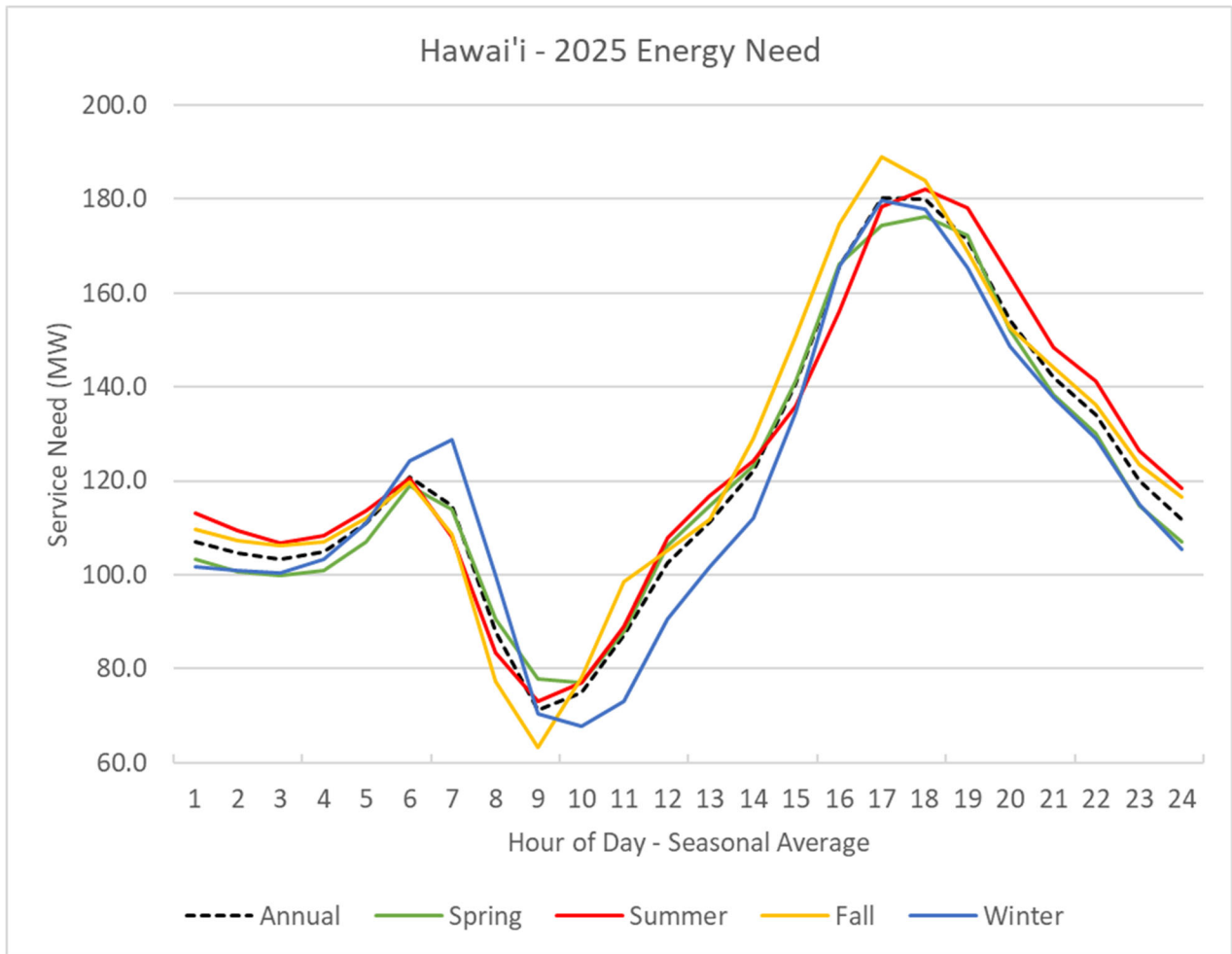

Figure 1: Hawai'i 2025 Need for Energy

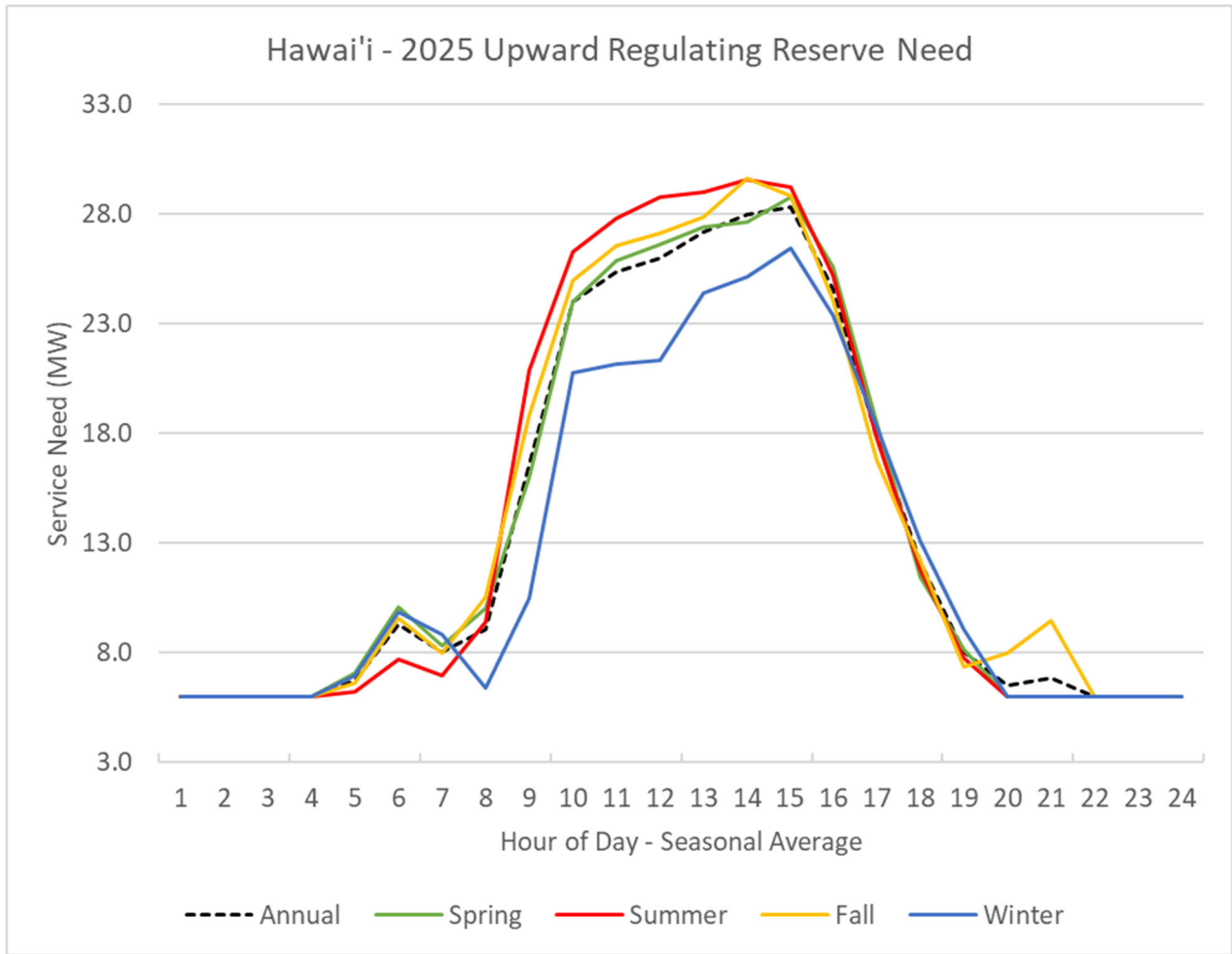

Figure 2: Hawai'i 2025 Need for Upward Regulating Reserve

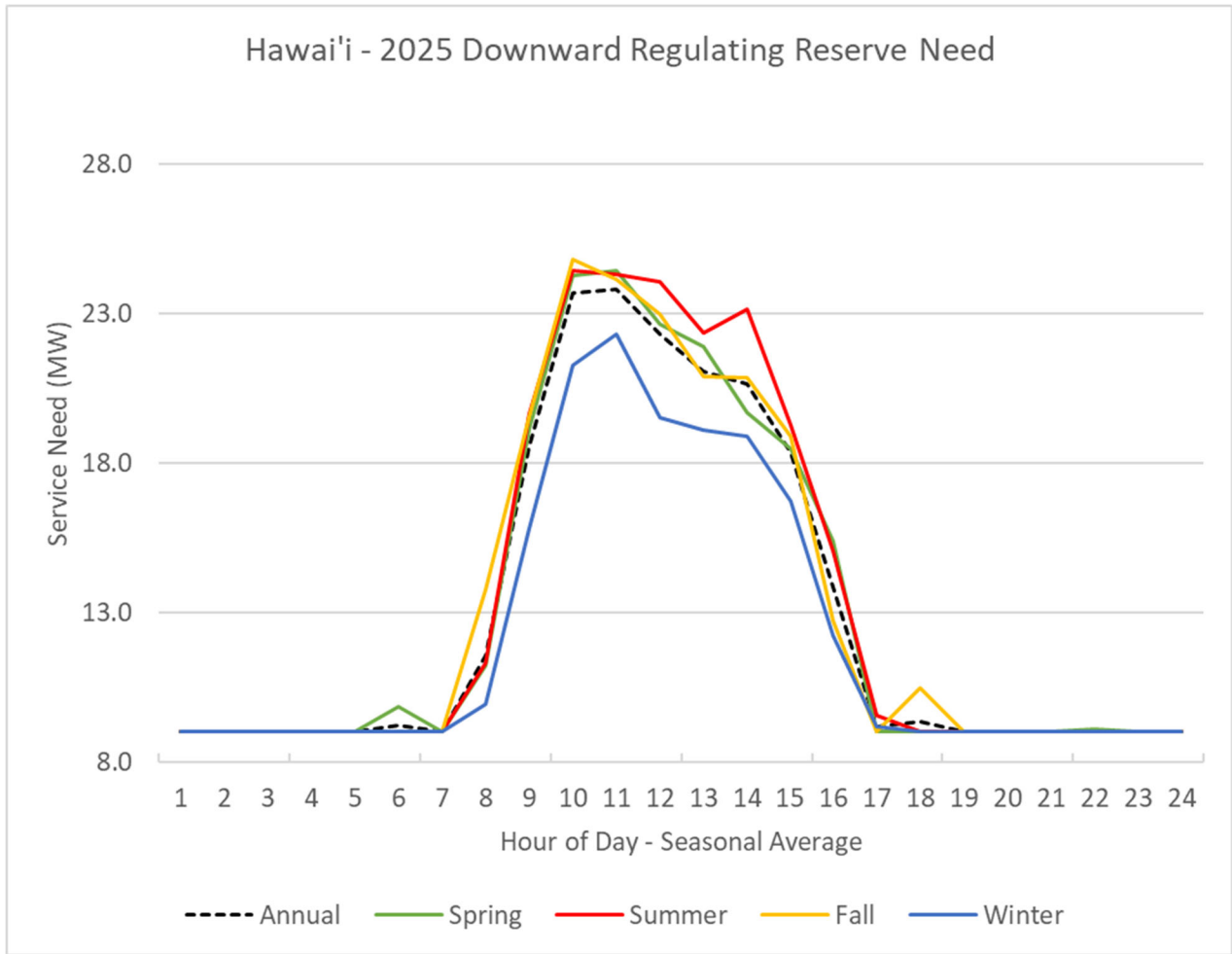

Figure 3: Hawai'i 2025 Need for Downward Regulating Reserve

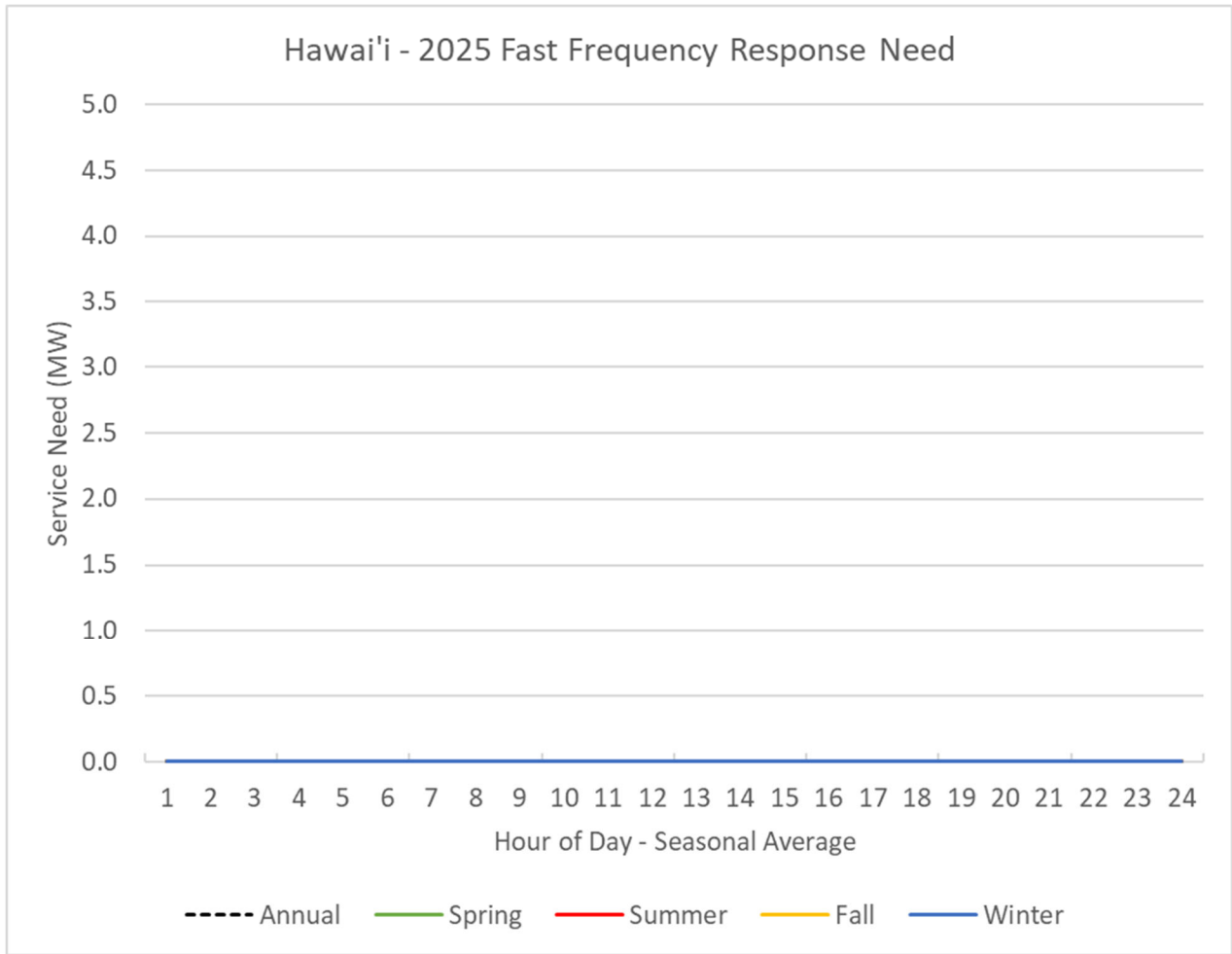

Figure 4: Hawai'i 2025 Need for Fast Frequency Response

### Grid Service Values

The charts below provide the relative marginal avoided costs for the grid services provided in Table 1.

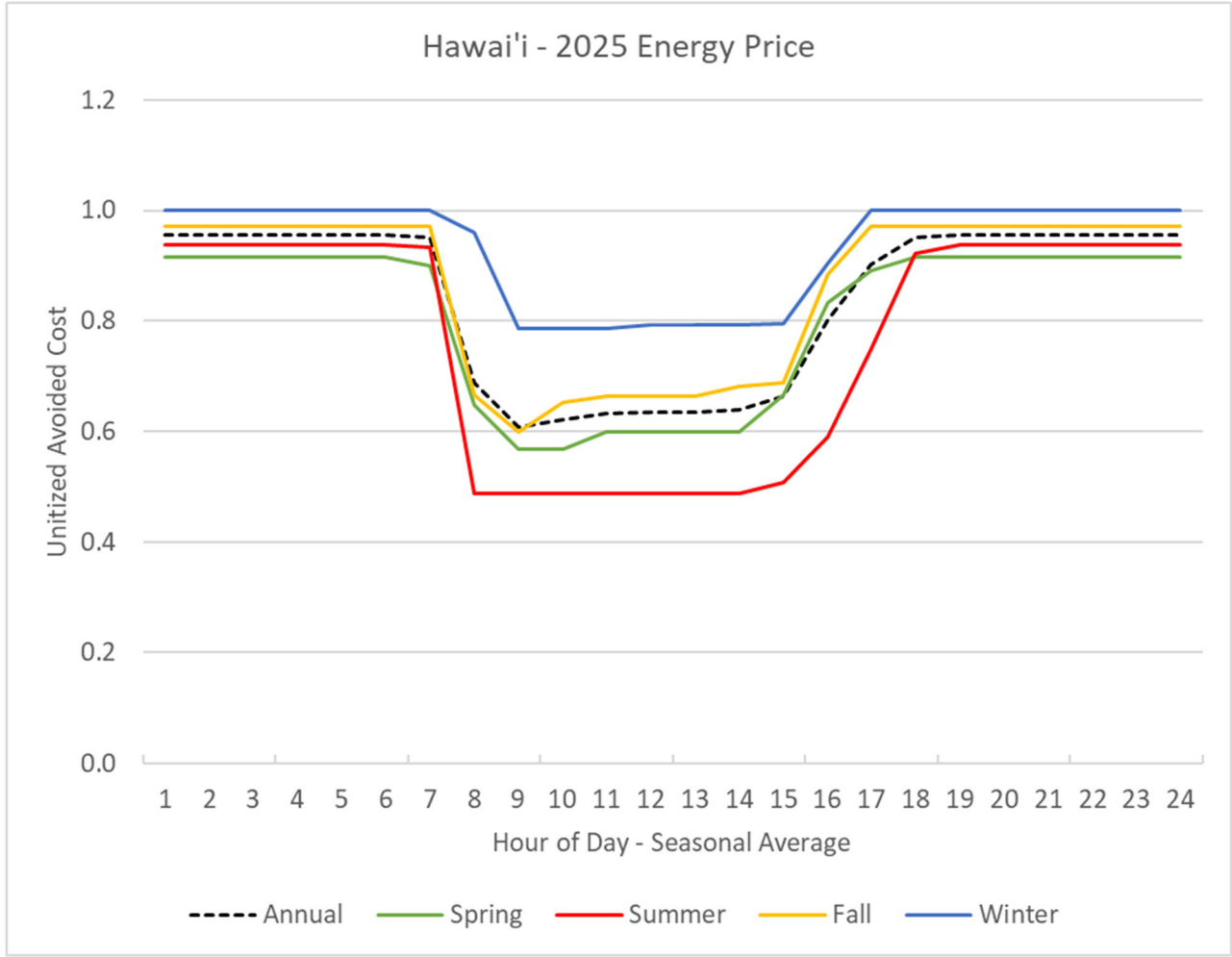

Figure 5: Hawai'i 2025 Price for Energy

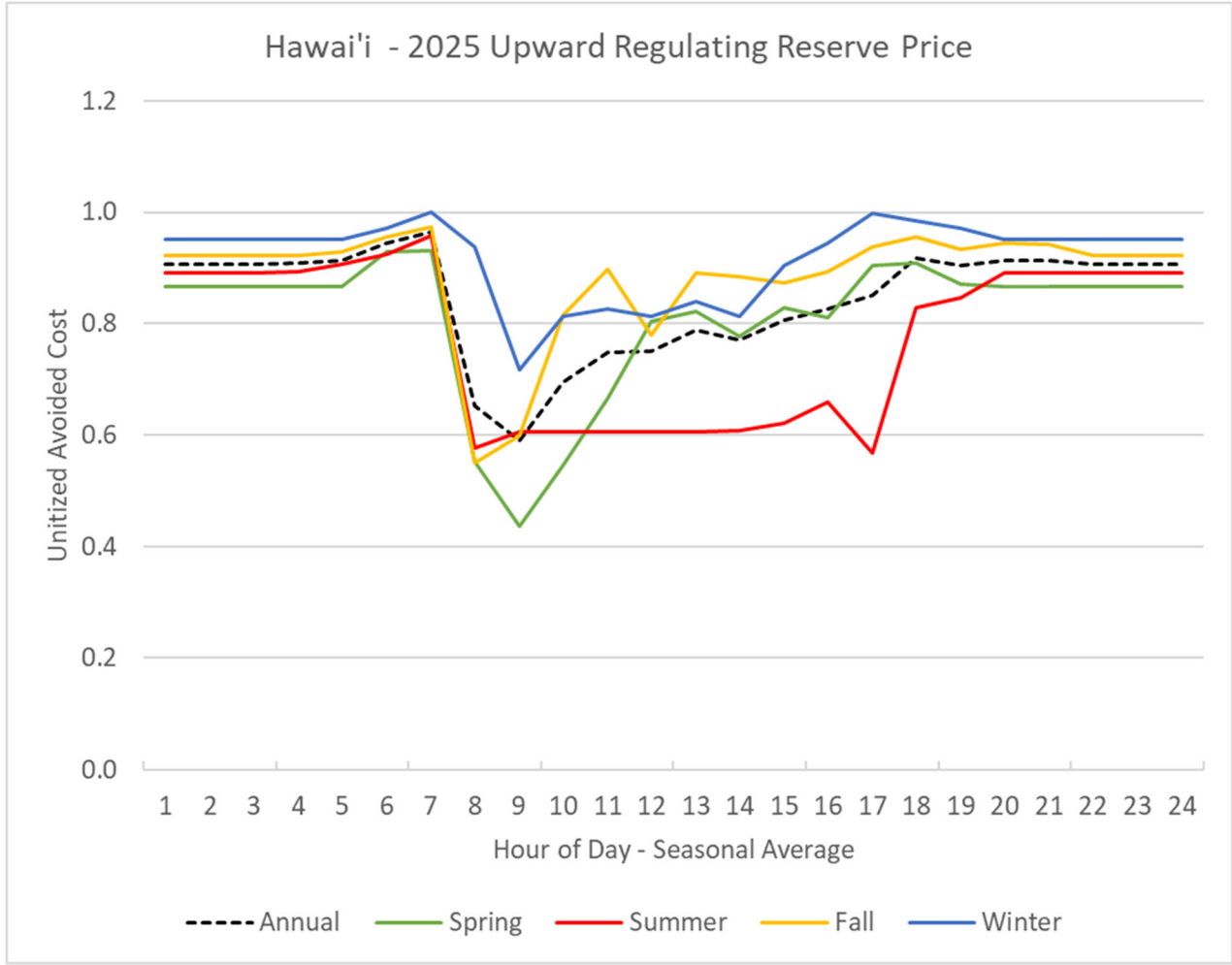

Figure 6: Hawai'i 2025 Price for Upward Regulating Reserve



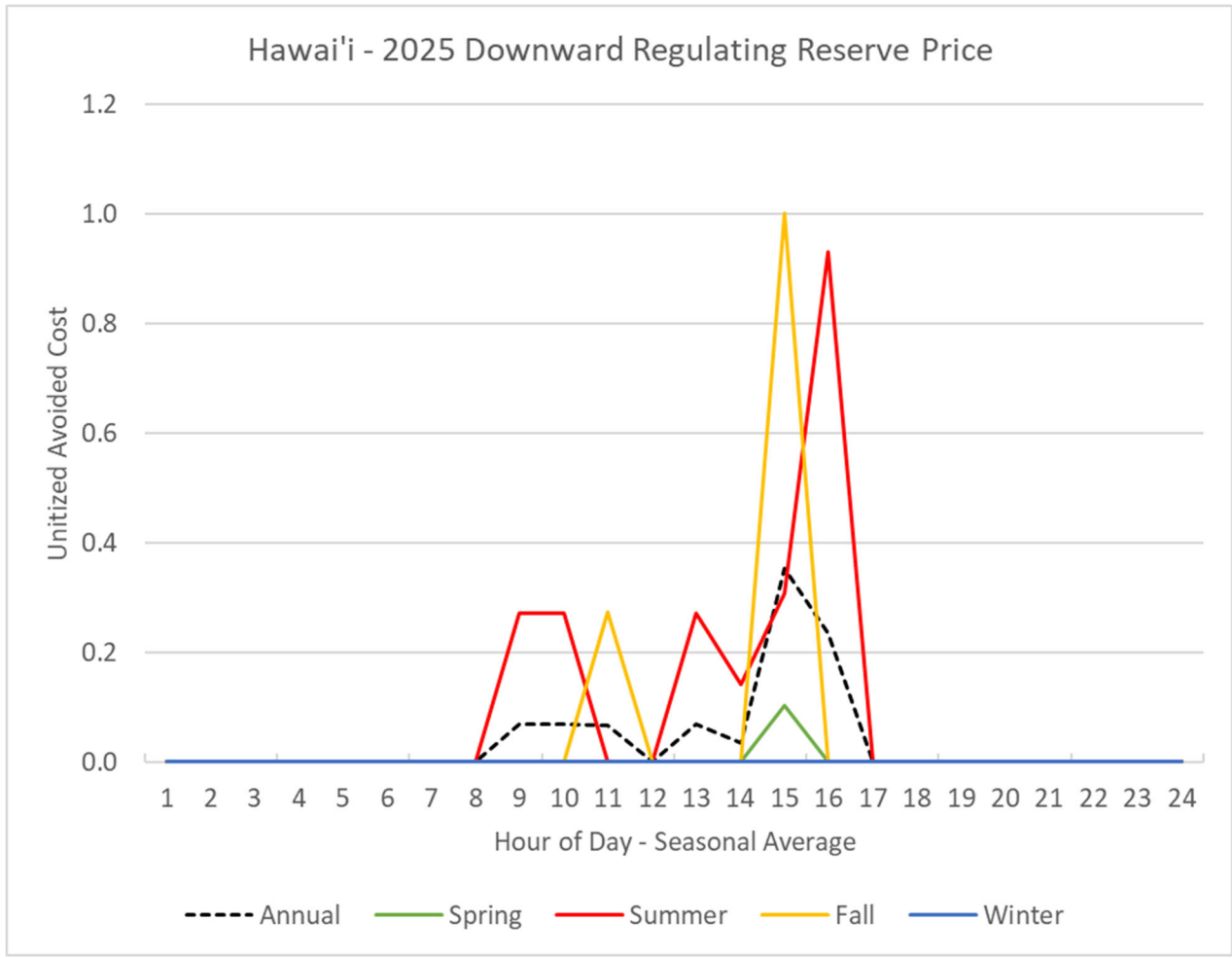

Figure 7: Hawai'i 2025 Price for Downward Regulating Reserve

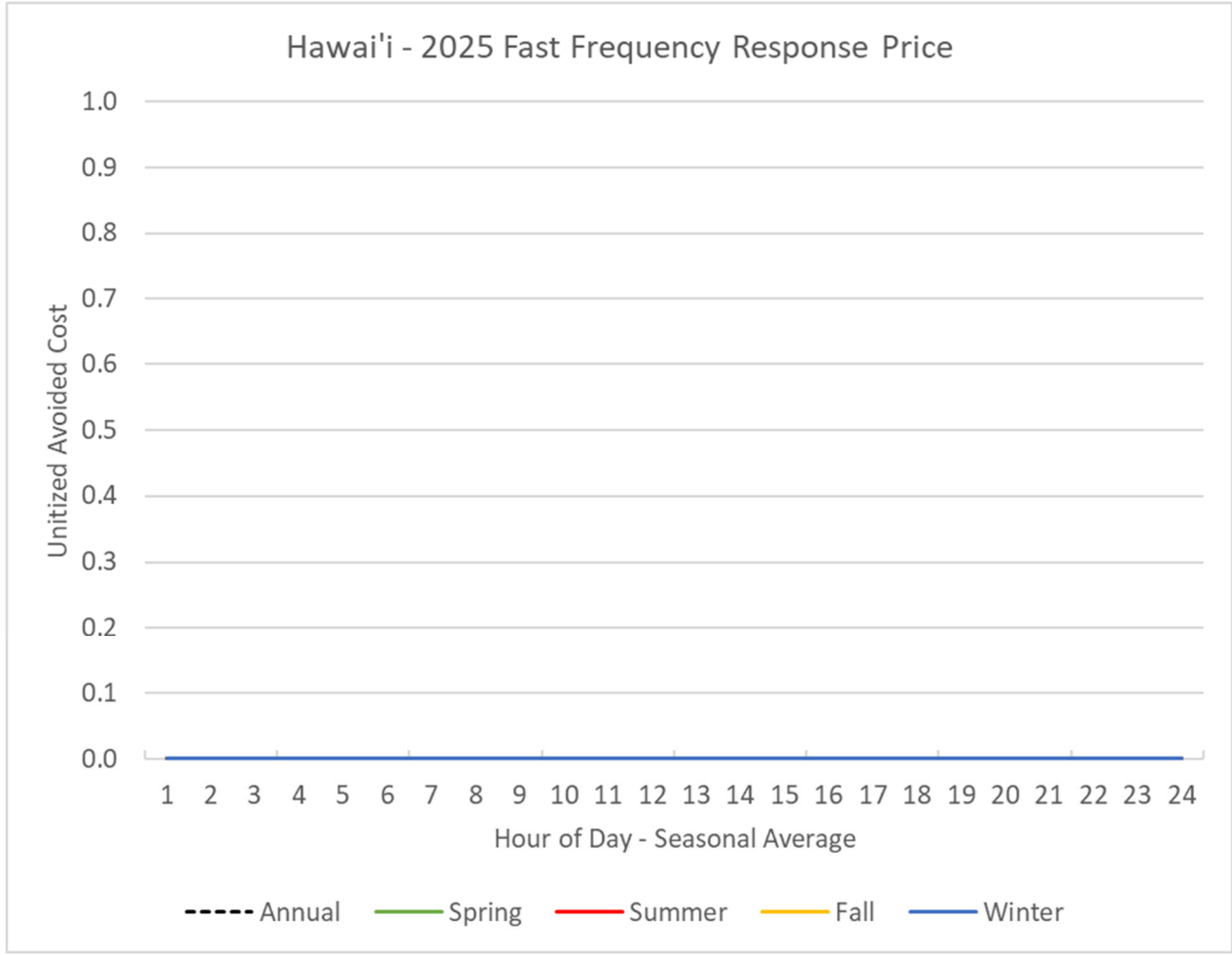

Figure 8: Hawai'i 2025 Price for Fast Frequency Response

For NWA needs, the distribution avoided cost will be based on the deferral value of the capital project to be deferred for projects offering to meet that service by siting a project on a circuit with distribution grid needs with a certainty rating of 1. A certainty rating of “1” means that there is an existing need; need identified within 3 years (could be due to “natural” load growth or specific new service requests); or a need identified within 4-5 years due to a new service request.<sup>2</sup> A certainty rating of “0” means all other situations where a need may be identified.

<b>Need or Distribution Service</b>	<b>Year of Need</b>	<b>Location</b>	<b>MW Need</b>	<b>Time of Day</b>	<b>Certainty Rating</b>	<b>LVM Grid Need Name</b>
Distribution Capacity or Distribution Reliability (back-tie)	202X	Circuits/Transformer	Size of overload (or load increase that caused voltage issue)	Daytime or Evening	1 or 0	Grid Need Name
Distribution Capacity	2020	Halaula 1 Circuit	0.3	Both	1	Grid Need Hawaii - A

---

<sup>2</sup> New service request is defined as a request made to the Company by an electrical contractor or electrical consultant that includes drawings, plans, electrical loading, and in-service information

**DRAFT**

**REQUEST FOR PROPOSALS**

**FOR**

**COMMUNITY-BASED RENEWABLE ENERGY TRANCHE 1**

**ISLAND OF HAWAI‘I**

DECEMBER 1, 2020

Docket No. 2015-0389

*Appendix P – Term Sheet for Large CBRE DC-  
Coupled Projects (PV + BESS)*

**[NOTE: Please refer to Exhibit 16 of this December 1, 2020 filing  
for the proposed Term Sheet for Large CBRE DC-Coupled Projects.]**



**Hawai'i  
Electric  
Light**

# EXHIBIT 7

Draft CBRE Tranche 1 Request for Proposals for Oahu

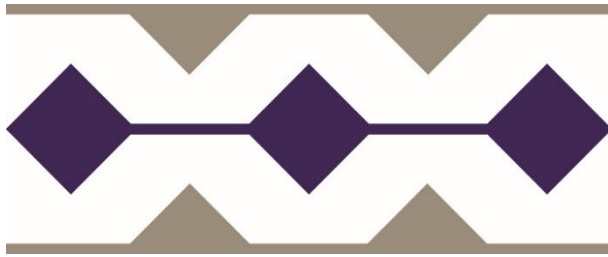

# Hawaiian Electric

**DRAFT**

**REQUEST FOR PROPOSALS**

**FOR**

**COMMUNITY-BASED RENEWABLE ENERGY TRANCHE 1**

**ISLAND OF O‘AHU**

DECEMBER 1, 2020

Docket No. 2015-0389

This Request for Proposals (“RFP”) is a DRAFT only. Hawaiian Electric Company, Inc. (“Hawaiian Electric” or “Company”) will employ a competitive bidding process to select renewable energy projects including Community Based Renewable Energy consistent with the State of Hawai‘i Public Utilities Commission’s (“PUC”) Competitive Bidding Framework. Under the Competitive Bidding Framework, Hawaiian Electric filed the initial draft RFP with the PUC. Then, Hawaiian Electric sought input from prospective Proposers and other stakeholders through a Technical Conference as described in the draft RFP and modified the draft RFP to the extent feasible to address input received in order to foster a robust competitive process. The proposed final RFP is being submitted to the PUC for approval and is subject to further revision based upon direction received from the PUC. After approval by the PUC, Hawaiian Electric will issue the final RFP.

## Table of Contents

Chapter 1: Introduction and General Information .....	1
1.1 Authority and Purpose of the Request for Proposals .....	2
1.2 Scope of the RFP .....	2
1.3 Competitive Bidding Framework .....	5
1.4 Role of the Independent Observer .....	5
1.5 Communications Between the Company and Proposers – Code of Conduct Procedures Manual.....	6
1.6 Company Contact for Proposals .....	6
1.7 Proposal Submittal Requirements.....	6
1.8 Proposal Fee.....	8
1.9 Procedures for the Self-Build or Affiliate Proposals .....	9
1.10 Dispute Resolution Process.....	11
1.11 No Protest or Appeal.....	12
1.12 Modification or Cancellation of the Solicitation Process .....	12
Chapter 2: Resource Needs and Requirements.....	12
2.1 Performance Standards .....	12
2.2 System Information.....	13
2.3 Interconnection to the Company System .....	13
Chapter 3: Instructions to Proposers .....	15
3.1 Schedule for the Proposal Process .....	15
3.2 Company RFP Website / Electronic Procurement Platform.....	15
3.3 Information Exchange.....	16
3.4 Preparation of Proposals .....	16
3.5 Organization of the Proposal .....	17
3.6 Proposal Limitations .....	17
3.7 Proposal Compliance and Bases for Disqualification.....	18
3.8 Power Purchase Agreement .....	18
3.9 Pricing Requirements.....	20
3.10 Project Description.....	21
3.11 Sites Identified by the Company.....	22
3.12 Confidentiality .....	23

3.13	Credit Requirements .....	24
Chapter 4: Evaluation Process and Evaluation Criteria.....		25
4.1	Proposal Evaluation and Selection Process .....	25
4.2	Eligibility Requirements Assessment .....	27
4.3	Threshold Requirements Assessment .....	28
4.4	Initial Evaluation – Price and Non-Price Analysis .....	30
4.5	Selection of a Priority List .....	38
4.6	Best and Final Offer (BAFO) .....	38
4.7	Detailed Evaluation.....	39
4.8	Selection of the Final Award Group .....	41
Chapter 5: Post Evaluation Process .....		41
5.1	Project Interconnection Process.....	41
5.2	Contract Negotiation Process.....	43
5.3	Community Outreach and Engagement.....	43
5.4	Greenhouse Gas Emissions Analysis.....	45
5.5	PUC Approval.....	45
5.6	Facility In-Service.....	46



## List of Appendices

Appendix A	Definitions
Appendix B	Proposer's Response Package / Project Interconnection Data Request
Appendix C	Code of Conduct Procedures Manual
Appendix D	PowerAdvocate User Information
Appendix E	Mutual Confidentiality and Non-Disclosure Agreement
Appendix F	Description of Available Sites
Appendix G	Self-Build Option and Self-Build Option Team Certification Form
Appendix H	Interconnection Facilities and Cost Information
Appendix I	Rule 19 Tariff
Appendix J	Rule 29 Tariff
Appendix K	Model PV Large RDG PPA
Appendix L	Model PV Mid-Tier Standard Form Contract RDG PPA (250 kW to 5 MW)
Appendix M	Model Wind Large RDG PPA
Appendix N	Model Wind Mid-Tier Standard Form Contract RDG PPA (250 kW to 5 MW)
Appendix O	Grid Needs Assessment
Appendix P	Term Sheet for Large CBRE DC-Coupled Projects (PV + BESS)

## **Chapter 1: Introduction and General Information**

Hawaiian Electric Company, Inc. (“Hawaiian Electric” or the “Company”) seeks proposals for Community-Based Renewable Energy (“CBRE”) projects, also referred to as shared solar,<sup>1</sup> in this Tranche 1 for the Hawaiian Electric System on the island of O‘ahu in accordance with this Request for Proposals (“RFP”).

The Company or its Affiliates may submit a Proposal in response to this RFP subject to the requirements of this RFP.

The Company seeks new variable renewable dispatchable generation projects (with or without storage systems) in this RFP. The total amount of CBRE generation sought in this RFP is 75 MW. For projects 250 kW or greater in size, up to and including 5 MW, a pre-approved standard form contract will be used in the form of Appendix L for photovoltaic (“PV”) generation projects and Appendix N for wind generation projects (“Mid-Tier SFC”). The Mid-Tier SFC treats variable generation facilities as fully dispatchable. For projects greater than 5 MW in size, the Company intends to contract for variable renewable dispatchable generation projects through this RFP using its Model Renewable Dispatchable Generation Power Purchase Agreement (“RDG PPA”), which treats variable generation facilities as fully dispatchable. The Company has created a PV version (the “PV RDG PPA”) and a wind version (the “Wind RDG PPA”) of its RDG PPA attached as Appendix K and Appendix M, respectively.

Each successful Proposer will provide variable renewable dispatchable generation and optionally, energy storage to the Company pursuant to the terms of an RDG PPA or Mid-Tier SFC. RDG PPAs for selected projects greater than 5 MW in size will be subject to review and approval by the State of Hawai‘i Public Utilities Commission (“PUC”), while the Mid-Tier SFCs for projects selected in this RFP that are 250 kW or greater in size, up to and including 5 MW will not be subject to further PUC review and approval.

The Company’s Model RDG PPA and Mid-Tier SFC employ an innovative contracting mechanism which is very different than traditional PPA structures. Proposers are instructed to thoroughly review the Model RDG PPA attached as Appendix J and L and the Mid-Tier SFC attached as Appendix K and M, based on the size and technology of their project. The structure of the RDG PPA and Mid-Tier SFC intends to provide payments to the Proposer by the Company on a monthly lump sum basis, based upon the energy potential of the facility, regardless of the actual energy dispatched. In exchange, the utility maintains full dispatch

---

<sup>1</sup> In response to some confusion in the community over the acronym “CBRE” that the Companies have experienced during their latest efforts to publicize the CBRE Program, the Companies are introducing the more descriptive term “shared solar” for the CBRE Program in an effort to alleviate any further confusion in the community. The Companies intent is to use both terms, “CBRE” in regulatory filings and “shared solar” in marketing and other Company literature to refer to the Community-Based Renewable Energy Program first introduced by the CBRE Framework. The term “shared solar” will be used even though the CBRE Program is not necessarily limited to PV projects only.

control of the Facility as needed.<sup>2</sup> Under the RDG PPA and Mid-Tier SFC, each Facility must meet certain requirements to receive the full lump sum payment each month. These requirements ensure that each plant is available to the Company for dispatch to meet system needs.

The Company will evaluate Proposals using the evaluation and selection process described in Chapter 4. The Company will evaluate and select Proposals based on both price and non-price factors that impact the Company, its customers, and communities affected by the proposed Projects. The number of Projects that the Company may acquire from this RFP depends on, among other things, the quality and cost-effectiveness of bids received in response to this RFP; economic comparison to other RFP responses; updates to the Company's forecasts; distribution availability; and changes to regulatory or legal requirements. If attractive Proposals are received that will provide energy and energy storage in excess of the targeted amounts, the Company will consider selecting such Proposal(s) if benefits to customers are demonstrated.

All requirements necessary to submit a Proposal(s) are stated in this RFP. A description of the technical requirements for Proposers is included in the body of this RFP, Appendix B, and in the applicable RDG PPA and Mid-Tier SFC attached as Appendix K, L, M, and N.

All capitalized terms used in this RFP shall have the meaning set forth in the glossary of defined terms attached as Appendix A. Capitalized terms that are not included in Appendix A shall have the meaning ascribed in this RFP.

## **1.1 Authority and Purpose of the Request for Proposals**

- 1.1.1 This RFP is issued in response to Order No. 37070 issued on April 20, 2020 and Order No. 37139 issued on May 14, 2020 in Docket No. 2015-0389 as part of a procurement process established by the PUC.
- 1.1.2 This RFP is subject to Decision and Order (“D&O”) No. 23121 in Docket No. 03-0372 (To Investigate Competitive Bidding for New Generating Capacity in Hawai‘i), which sets forth the PUC’s Framework for Competitive Bidding (“Framework” or “Competitive Bidding Framework”).
- 1.1.3 Proposers should review Appendix O, Grid Needs Assessment, to inform Proposers as to the system needs and costs based on inputs and assumptions developed through the Company’s integrated grid planning process, and recent renewable dispatchable generation procurements.<sup>3</sup> The Grid Needs Assessment is intended to inform the development of their Proposals that best meets the needs of the system.

---

<sup>2</sup> Wind projects may include a Price for Purchase of Electric/Renewable Energy component in addition to the Lump Sum Payment component. The energy payment would be based on actual production and delivery to the grid. As the RDG PPA and Mid-Tier SFC allow the Company dispatch rights and does not guarantee Seller any amount of energy will be delivered to the Point of Interconnection (POI), in the event that the Company does not accept any energy at the POI, the Company will not pay any Price for Electric/Renewable Energy.

<sup>3</sup> See <https://www.hawaiianelectric.com/clean-energy-hawaii/our-clean-energy-portfolio/renewable-project-status-board>

## 1.2 Scope of the RFP

- 1.2.1 Proposals submitted in response to this RFP shall meet the requirements identified in Part II and III of Tariff Rule No. 29, Community-Based Renewable Energy Program Phase 2, attached as Appendix J.
- 1.2.2 The Company will only accept Proposals that utilize PV or wind generation technologies. Proposals may be submitted as: (1) Generation only Projects; or (2) Generation paired with energy storage Projects (“Paired Projects”).
- 1.2.3 At least 40% of the Project’s capacity must be reserved for residential Subscribers with unsubscribed RDG compensation subject to the requirements in Article 2 of the applicable RDG PPA or Attachment C of the applicable Mid-Tier SFC. The capacity allocations (%) identified in the Proposal submission will be used in the RFP evaluation process and therefore Proposers will be held to their provided value.
- 1.2.4 Preference will be given to Projects whose Subscriber portion reserves an amount greater than 40% of Project capacity for residential customers and/or any additional amount of Project capacity dedicated to Low- and Moderate-Income Customers (“LMI Customers”), as defined in Tariff Rule No. 29 in Appendix J.
- 1.2.5 Each Proposal submitted in response to this RFP must represent a Project that is capable of meeting the requirements of this RFP without having to rely on the completion or implementation of any other Project, or without having to rely on a proposed change in law, rule, or regulation.
- 1.2.6 Proposals that will require system upgrades and the construction of which, in the reasonable judgment of the Company (in consultation with the Independent Observer), creates a significant risk that their Project’s Guaranteed Commercial Operations Date (“GCOD”) will not be met, will not be considered in this RFP.
- 1.2.7 Projects submitted in response to this RFP must be located on the Island of O‘ahu.
- 1.2.8 Proposers will determine their Project Site. Proposers have the option of submitting a Proposal using potential Sites offered and described in Section 3.11. Proposers must locate all Project infrastructure within areas of their Site that are outside the 3.2 feet sea level rise exposure area (SLR-XA) as described in the Hawai‘i Sea Level Rise Vulnerability and Adaptation Report (2017)<sup>4</sup> and are not located within a Tsunami Evacuation Zone.<sup>5</sup> All equipment required for a Proposer’s project must be sited within

---

<sup>4</sup> Hawai‘i Climate Change Mitigation and Adaptation Commission. 2017. Hawai‘i Sea Level Rise Vulnerability and Adaptation Report. Prepared by Tetra Tech, Inc. and the State of Hawai‘i Department of Land and Natural Resources, Office of Conservation and Coastal Lands, under the State of Hawai‘i Department of Land and Natural Resources Contract No: 64064. This report is available at: [https://climateadaptation.hawaii.gov/wp-content/uploads/2017/12/SLR-Report\\_Dec2017.pdf](https://climateadaptation.hawaii.gov/wp-content/uploads/2017/12/SLR-Report_Dec2017.pdf)

<sup>5</sup> See Hawai‘i Sea Level Rise Viewer at <https://www.pacioos.hawaii.edu/shoreline/slr-hawaii/>, and National Oceanic and Atmospheric Administration (NOAA) interactive map in partnership with the State of Hawai‘i at <https://tsunami.coast.noaa.gov/#/>. Projects infrastructure must be outside the “Tsunami Evacuation Zone” (but not necessary to be outside the “Extreme Tsunami Evacuation Zone”).

the Proposer's project site with no assumptions that any equipment will be sited on Company property unless specified by the Company.

- 1.2.9 Projects must interconnect to the Company's System at the sub-transmission or distribution level (46 kV or lower). Projects interconnecting at the distribution level (25 kV or lower) must not exceed 3 MW.
- 1.2.10 Projects submitted in response to this RFP must be 250 kW or larger. Proposers for CBRE projects smaller than 250 kW should refer to the Company's CBRE website for instructions on how to submit proposals at [www.hawaiianelectric.com/communitysolar](http://www.hawaiianelectric.com/communitysolar).
- 1.2.11 Contracts for Projects selected through this RFP must use the RDG PPA or Mid-Tier SFC, as described in [Section 3.8](#). Under the RDG PPA and Mid-Tier SFC, the Company shall maintain exclusive rights to fully direct dispatch of the Facility, subject to availability of the resource and [Section 1.2.12](#) below. The term of the PPA will be 20 years.
- 1.2.12 The storage component of a Paired Project will be charged during periods when full potential export of the generation component is not being dispatched by the Company, and the storage component can be used to provide energy to the Company during other times that are beneficial to the system. The storage component of a Paired Project must be sized to support the Facility's Allowed Capacity (in MW) for a minimum of four (4) continuous hours throughout the term of the RDG PPA or Mid-Tier SFC.  
  
For example, for a 2 MW facility, the storage component must be able to store and discharge at least 8 MWh of energy at 2 MW in a cycle throughout the term of the RDG PPA or Mid-Tier SFC.
- 1.2.13 Grid-charging is not required for Paired Projects. However, if grid-charging capability is included, the Paired Project must be able to be charged from the grid at the direction of the Company after the 5-year Investment Tax Credit ("ITC") recapture period has lapsed. Paired Projects electing to include grid-charging capability that are incapable of claiming the ITC must be capable of being 100% charged from the grid from the GCOD.
- 1.2.14 The amount of energy discharged from any energy storage component in a year will be limited to the energy storage contract capacity (in MWh) multiplied by the number of Days in that year. An energy storage component may be dispatched more than once per Day, subject to such discharge energy limitations.
- 1.2.15 Proposals must specify a GCOD no later than March 31, 2026. Preference will be given to Proposals that specify an earlier GCOD during the non-price evaluation. A Proposer's GCOD set forth in its Proposal will be the GCOD in any resulting RDG PPA or Mid-Tier SFC if such Proposal is selected to the Final Award Group. Proposers will not be able to request a change in the GCOD set forth in their Proposals. Proposals that propose an earlier GCOD will be scored higher during the Initial Evaluation phase ([see Chapter 4](#)).
- 1.2.16 If selected, Proposers will be responsible for all costs throughout the term of the RDG PPA or Mid-Tier SFC, including but not limited to Project development, completion of

an Interconnection Requirements Study (“IRS”), the cost of conducting a greenhouse gas analysis, land acquisition, permitting, financing, construction of the Facility and all Interconnection Facilities, and the operation and maintenance (“O&M”) of the Facility.

- 1.2.17 If selected, Proposers will be solely responsible for the decommissioning of the Project and the restoration of the Site upon the expiration of the PPA, as described in Attachment G, Section 7 of the RDG PPA or the Mid-Tier SFC.
- 1.2.18 If selected, Proposers shall pursue all available applicable federal and state tax credits. Proposal pricing must be set to incorporate the benefit of such available federal tax credits. However, to mitigate the risk on Proposers due solely to potential changes to the state’s tax credit law before a selected project reaches commercial operations, Proposal pricing shall be set without including any state tax credits. If a Proposal is selected, the PPA for the project will require the Proposer to pursue the maximum available state tax credit and remit tax credit proceeds to the Company for customers’ benefit as described in Attachment J of the RDG PPA or the Mid-Tier SFC. The PPA will also provide that the Proposer will be responsible for payment of liquidated damages for failure to pursue the state tax credit.

### **1.3 Competitive Bidding Framework**

Consistent with the Framework, this RFP outlines the Company’s requirements in relation to the resources being solicited and the procedures for conducting the RFP process. It also includes information and instructions to prospective Proposers participating in and responding to this RFP.

### **1.4 Role of the Independent Observer**

- 1.4.1 Part III.C.1 of the Framework sets forth the circumstances under which an Independent Observer is required in a competitive bidding process. The Independent Observer will advise and monitor all phases of the RFP process and will coordinate with PUC staff throughout the RFP process to ensure that the RFP is undertaken in a fair and unbiased manner. In particular, the Company will review and discuss with the Independent Observer decisions regarding the evaluation, disqualification, non-selection, and selection of Proposals.
- 1.4.2 The role of the Independent Observer, as described in the Framework, will include but is not limited to:
- Monitor all steps in the competitive bidding process
  - Monitor communications (and communications protocols) with Proposers
  - Monitor adherence to the Company’s Code of Conduct
  - Submit comments and recommendations, if any, to the PUC concerning the RFP
  - Review the Company’s Proposal evaluation methodology, models, criteria, and assumptions
  - Review the Company’s evaluation of Proposals
  - Advise the Company on its decision-making
  - Participate in dispute resolution as set forth in Section 1.10

- Monitor contract negotiations with Proposers
- Report to the PUC on monitoring results during each stage of the competitive bidding process
- Provide an overall assessment of whether the goals of the RFP were achieved

1.4.3 The Independent Observer for this RFP is: **Arroyo Seco Consulting**.

## **1.5 Communications Between the Company and Proposers – Code of Conduct Procedures Manual**

1.5.1 Communications and other procedures under this RFP are governed by the “Code of Conduct Procedures Manual,” (also referred to as the “Procedures Manual”) developed by the Company as required by the Framework, and attached as Appendix C.

1.5.2 All pre-Proposal communication with prospective Proposers will be conducted via the Company’s RFP website, Electronic Procurement Platform, and/or electronic mail (“Email”) through the address specified in Section 1.6 (the “RFP Email Address”). Phone communication or face-to-face meetings will not be supported. Frequently asked questions submitted by prospective Proposers and the answers to those questions may be posted on the Company’s RFP website. The Company reserves the right to respond only to comments and questions it deems are appropriate and relevant to the RFP. Proposers shall submit questions no later than fifteen Days before the Proposal Due Date (RFP Schedule in Section 3.1, Items 6 and 7). The Company will endeavor to respond to all questions no later than five Days before the Proposal Due Date.

1.5.3 After Proposals have been submitted, the Company may contact individual Proposers for purposes of clarifying their Proposal(s).

1.5.4 Any confidential information deemed by the Company, in its sole discretion, to be appropriate to share, will only be transmitted to the requesting party after receipt of a fully executed CBRE Mutual Confidentiality and Non-Disclosure Agreement (“CBRE NDA”). See Appendix E.

1.5.5 Except as expressly permitted and in the manner prescribed in the Procedures Manual, any unsolicited contact by a Proposer or prospective Proposer with personnel of the Company pertaining to this RFP is prohibited.

## 1.6 Company Contact for Proposals

The primary contact for this RFP is:

Jasmine Wong  
Energy Contract Manager  
Hawaiian Electric Company, Inc.

RFP Email Address: [cbrrerfp@hawaiianelectric.com](mailto:cbrrerfp@hawaiianelectric.com)

## 1.7 Proposal Submission Requirements

- 1.7.1 All Proposals must be prepared and submitted in accordance with the procedures and format specified in the RFP. Proposers are required to respond to all questions and provide all information requested in the RFP, as applicable, and only via the communication methods specified in the RFP.
- 1.7.2 Detailed requirements regarding the form, submission, organization and information for the Proposal are set forth in Chapter 3 and Appendix B.
- 1.7.3 Proposals must not rely on any information that is not contained within the Proposal itself in demonstrating compliance for any requirement in this RFP.
- 1.7.4 In submitting a Proposal in response to this RFP, each Proposer certifies that the Proposal has been submitted in good faith and without fraud or collusion with any other unaffiliated person or entity. The Proposer shall acknowledge this in the Response Package submitted with its Proposal. Furthermore, in executing the CBRE NDA provided as Appendix E, the Proposer agrees on behalf of its Representatives (as defined in the CBRE NDA) that the Company's negotiating positions will not be shared with other Proposers or their respective Representatives.

In addition, in submitting a Proposal, a Proposer will be required to provide Company with its legal counsel's written certification in the form attached as Appendix B Attachment 1 certifying in relevant part that irrespective of any Proposer's direction, waiver, or request to the contrary, that the attorney will not share a Proposer's confidential information associated with such Proposer with others, including, but not limited to, such information such as a Proposer's or Company's negotiating positions. If legal counsel represents multiple unaffiliated Proposers whose Proposals are selected for the Final Award Group, such counsel will also be required to submit a similar certification at the conclusion of power purchase agreement negotiations that he or she has not shared a Proposer's confidential information or the Company's confidential information associated with such Proposer with others, including but not limited to, such information as a Proposer's or Company's negotiating positions.

- 1.7.5 All Proposals must be submitted via the Electronic Procurement Platform by 2:00 pm Hawai'i Standard Time ("HST") on the Proposal Due Date shown in the RFP Schedule in Section 3.1, Table 1, Item 6 and 7. No hard copies of these Proposals will be accepted by the Company.



It is the Proposer’s sole responsibility to ensure that complete and accurate information has been submitted on time and consistent with the instructions of this RFP. With this assurance, Company shall be entitled to rely upon the completeness and accuracy of every Proposal. Any errors identified by the Proposer or Company after the Proposal Due Date has passed may jeopardize further consideration and success of the Proposal. If an error or errors are later identified, Company, in consultation with the Independent Observer, may permit the error(s) to be corrected without further revision to the Proposal, or may require Proposer to adhere to terms of the Proposal as submitted without correction. Additionally, and in Company’s sole discretion, if such error(s) would materially affect the Priority List or Final Award Group, Company reserves the right, in consultation with the Independent Observer, to remove or disqualify a Proposal upon discovery of the material error(s). The Proposer of such Proposal shall bear the full responsibility for such error(s) and shall have no recourse against Company’s decision to address Proposal error(s), including removal or disqualification. The Energy Contract Manager, in consultation with the Independent Observer, will confirm that the Self-Build Proposals were submitted by the Self-Build Proposal Due Date shown in Section 3.1, Table 1, Item 6. The Electronic Procurement Platform automatically closes to further submissions after the IPP and Affiliate Proposal Due Date shown in Section 3.1, Table 1, Item 7.

**1.8 Proposal Fee**

1.8.1 IPP and Affiliate proposers are required to tender a non-refundable Proposal Fee, based on the size of the proposed Project, for each Proposal submitted.

<b>Project Size</b>	<b>Proposal Fee</b>
250 kW and larger, up to and including 2.5 MW	\$2,000
Larger than 2.5 MW, up to and including 10 MW	\$5,000
Larger than 10 MW	\$10,000

1.8.2 Proposers may submit up to two (2) variations of their Proposal, one of which is the base variation of the Proposal, under a single Proposal Fee.

1.8.3 Variations of pricing terms, Facility size or with/without storage can be offered. Variations which propose a different Site or different generation technology will not be considered and will be deemed a separate Proposal, and a separate Proposal Fee must be paid for each such Proposal. All unique information for each variation of a Proposal, no matter how minor such variation is, must be clearly identified and separated by following the instructions in Appendix B Section 4.

- 1.8.4 The Proposal Fee must be in the form of a cashier's check or equivalent from a U.S.-chartered bank made payable to "Hawaiian Electric Company, Inc." and must be delivered and received by the Company by 2:00 pm (HST) on the Proposal Due Date shown in the RFP Schedule in Section 3.1, Table 1, Item 7. The cashier's check should include a reference to the Proposal(s) for which the Proposal Fee is being provided. Proposers must identify in the Proposal Response Package (instructions in Appendix B Section 1.3.1) the delivery information for its Proposal Fee. Proposers are strongly encouraged to utilize a delivery service method that provides proof of delivery to validate delivery date and time.

If the Proposal Fee is delivered by U.S. Postal Service (with registered, certified, receipt verification), the Proposer shall address it to:

Jasmine Wong  
Energy Contract Manager  
Hawaiian Electric Company, Inc.  
Mail Code CP21-IU  
PO Box 2750  
Honolulu, Hawai'i 96840

If the Proposal Fee is delivered by other courier services, the Proposer shall address it to:

Hawaiian Electric Company, Inc.  
Ward Receiving  
Attention: Jasmine Wong, Energy Contract Manager  
Mail Code CP21-IU  
799 S. King St.  
Honolulu, Hawai'i 96813

Due to COVID-19 disease prevention measures, Proposal Fees cannot be delivered in person.

## **1.9 Procedures for the Self-Build or Affiliate Proposals**

- 1.9.1 Order No. 37070 states that the CBRE RFPs will be open to all bidders, including the Company. The Competitive Bidding Framework allows the Company the option to offer a Proposal(s) in response to this RFP ("Self-Build Option" or "SBO"). Accordingly, the Company must follow certain requirements and procedures designed to safeguard against and address concerns associated with: (1) preferential treatment of the SBO or members, agents, or consultants of the Company formulating the SBO (the "Self-Build Team"); and (2) preferential access to proprietary information by the Self-Build Team. These requirements are specified in the Code of Conduct ("CBRE Code of Conduct") required under the Framework and implemented by certain rules and procedures found in the Procedures Manual submitted to the PUC in Docket No. 2015-0389 on October 9, 2020. The CBRE Code of Conduct will apply to all CBRE Phase 2 RFPs, regardless of whether the Company submits an SBO Proposal. A copy of the Procedures Manual is attached as Appendix C.

The Competitive Bidding Framework also allows Affiliates of the Company to submit Proposals<sup>6</sup> to RFPs issued by the Company. All Self-Build and Affiliate Proposals are subject to the Company's Code of Conduct and the Procedures Manual. Affiliate Proposals are also subject to any applicable Affiliate Transaction Requirements issued by the PUC in Decision and Order No. 35962 on December 19, 2018, and subsequently modified by Order No. 36112, issued on January 24, 2019, in Docket No. 2018-0065. However, for Affiliate Proposals with nameplate capacities that are 250 kW or greater in size, up to and including 5 MW, the PUC will not require an additional review pursuant to the Affiliate Transaction Requirements, but will hold Affiliate Proposals to the terms of their Proposals. Affiliate Proposals will be treated identically to IPP Proposals and must be submitted electronically through the Electronic Procurement Platform by IPP and Affiliate Proposal Due Date in RFP Section 3.1, Table 1, Item 7.

- 1.9.2 The Company will require that the Proposal for the SBO(s) and Affiliate Proposals be submitted electronically through the Electronic Procurement Platform. SBO Proposals will be due a minimum of one (1) Day before other Proposals are due. A Proposal for the SBO will be uploaded into the Electronic Procurement Platform in the same manner Proposals from other Proposers are uploaded. The Energy Contract Manager, in consultation with the Independent Observer, will confirm that the Self-Build Proposals are timestamped by the Self-Build Proposal Due Date found in RFP Section 3.1, Table 1, Item 6.
- 1.9.3 Detailed requirements for an SBO Proposal can be found in Appendix G. These requirements are intended to provide a level playing field between SBO Proposals and third-party Proposals. Except where specifically noted, an SBO Proposal must adhere to the same price and non-price Proposal requirements as required of all Proposers, as well as certain RDG PPA or Mid-Tier SFC requirements, such as milestones and liquidated damages, as described in Appendix G. The non-negotiability of the Performance Standards shall apply to any SBO to the same extent it would for any other Proposal. Notwithstanding the fact that it will not be required to enter into an RDG PPA or Mid-Tier SFC with the Company, a Self-Build Proposer will be required to note its exceptions, if any, to the RDG PPA for Projects over 5 MW in the same manner required of other Proposers, and will be held to such modified parameters if selected. In addition to its Proposal, the Self-Build Team will be required to submit Appendix G Attachment 1, Self-Build Option Team Certification Form, acknowledging it has followed the rules and requirements of the RFP to the best of its ability and has not engaged in any collusive actions or received any preferential treatment or information providing an impermissible competitive advantage to the Self-Build Team over other Proposers responding to this RFP, as well as adherence to RDG PPA or Mid-Tier SFC terms and milestones required of all Proposers and the SBO's proposed cost protection measures.

The cost recovery methods between a regulated utility SBO Proposal and IPP Proposals are fundamentally different due to the business environments they operate in. As a result,

---

<sup>6</sup> A Proposal will also be treated as an Affiliate Proposal if the Affiliate is a partner for the Proposal.

the Company has instituted a process to compare the two types of proposals for the initial evaluation of the price related criteria on a ‘like’ basis through comparative analysis.

At the core of an SBO Proposal are its total project capital cost and any associated annual operations and maintenance (“O&M”) costs. During the RFP’s initial pricing evaluation step, these capital costs<sup>7</sup> and O&M costs will be used in a revenue requirement calculation to determine the estimated revenues needed from customers which would allow the Company to recover the total cost of the project. The SBO revenue requirements are then used in a levelized benefit calculation to determine a Levelized Benefit (“LB”) (\$/MWh) which will then be used for comparison to IPP and any Affiliate Proposals.

The Company, in conjunction with the Independent Observer, may also conduct a risk assessment of the SBO Proposal to ensure an appropriate level of customer cost protection measures are included in such Proposal.

If the SBO is not included in any shared savings mechanism for this RFP pre-approved by the Commission, the SBO will be permitted to submit a shared savings mechanism with its Proposal to share in any cost savings between the amount of cost bid in the SBO Proposal and the actual cost to construct the Project. If the SBO Proposal is selected to the Final Award Group, the proposed shared savings mechanism will need to be approved by the PUC. Submission of a shared savings mechanism is not required and will not be considered in the evaluation of the SBO Proposal.

## **1.10 Dispute Resolution Process**

- 1.10.1 If disputes arise under the RFP, the provisions of Section 1.10 and the dispute resolution process established in the Framework will control. See Part V of the Framework.
- 1.10.2 Proposers who challenge or contest any aspect of the RFP process must first attempt to resolve their concerns with the Company and the Independent Observer (“Initial Meeting”). The Independent Observer will seek to work cooperatively with the parties to resolve any disputes or pending issues and may offer to mediate the Initial Meeting to resolve disputes prior to such issues being presented to the PUC.
- 1.10.3 Any and all disputes arising out of or relating to the RFP which remain unresolved for a period of twenty (20) Days after the Initial Meeting takes place may, upon the agreement of the Proposer and the Company, be submitted to confidential Mediation in Honolulu, Hawai‘i, pursuant to and in accordance with the Mediation Rules, Procedures, and Protocols of Dispute Prevention Resolution, Inc. (“DPR”) (or its successor) or, in its absence, the American Arbitration Association then in effect (“Mediation”). The Mediation will be administered by DPR. If the parties agree to submit the dispute to Mediation, the Proposer and the Company shall each pay fifty percent (50%) of the cost

---

<sup>7</sup> SBO Proposals will be required to provide a table identifying project costs by year. These capital costs should be all inclusive, including but not limited to costs associated with equipment, Engineering, Procurement, and Construction (“EPC”), interconnection, overhead, and Allowance for Funds Used During Construction (“AFUDC”).

of the Mediation (i.e., the fees and expenses charged by the mediator and DPR) and shall otherwise each bear their own Mediation costs and attorney's fees.

- 1.10.4 If settlement of the dispute is not reached within sixty (60) Days after commencement of the Mediation, or if after the Initial Meeting, the parties do not agree to submit any unresolved disputes to Mediation, then as provided in the Framework, the Proposer may submit the dispute to the PUC in accordance with the Framework.
- 1.10.5 In accordance with the Framework, the PUC will serve as the arbiter of last resort for any disputes relating to this RFP involving Proposers. The PUC will use an informal expedited dispute resolution process to resolve the dispute within thirty (30) Days, as described in Parts III.B.8 and V of the Framework.<sup>8</sup> There will be no right to hearing or appeal from this informal expedited dispute resolution process.
- 1.10.6 If any Proposer initiates a dispute resolution process for any dispute or claim arising under or relating to this RFP, other than that permitted by the Framework and Section 1.10 (e.g., a court proceeding), then such Proposer shall be responsible for any and all attorneys' fees and costs that may be incurred by the Company or the PUC in order to resolve such claim.

#### **1.11 No Protest or Appeal**

Subject to Section 1.10, no Proposer or other person will have the right to protest or appeal any award or disqualification of a Project made by the Company.

By submitting a Proposal in response to the RFP, the Proposer expressly agrees to the terms and conditions set forth in this RFP.

#### **1.12 Modification or Cancellation of the Solicitation Process**

- 1.12.1 Unless otherwise expressly prohibited, the Company may, at any time up to the final execution of an RDG PPA or Mid-Tier SFC, as may be applicable, in consultation with the Independent Observer, postpone, withdraw, and/or cancel any requirement, term, or condition of this RFP, including deferral of the award or negotiation of any contract, and/or cancellation of the award all together, all of which will be without any liability to the Company.
- 1.12.2 The Company may modify this RFP subject to requirements of the Framework, whereby the modified RFP will be reviewed by the Independent Observer and submitted to the PUC thirty (30) Days prior to its issuance, unless the PUC directs otherwise. See Framework Part IV.B.10. The Company will follow the same procedure with regard to

---

<sup>8</sup> The informal expedited dispute resolution process does not apply to PUC review of contracts that result from the RFP. See Decision and Order No. 23121 at 34-35. Further, the informal expedited dispute resolution process does not apply to the Framework's process relating to issuance of a draft and final RFP, and/or to the PUC approval of the RFP because: (1) the Framework (and the RFP) set forth specific processes whereby interested parties may provide input through the submission of comments; and (2) the Framework's dispute resolution process applies to "Bidders" and there are no "Bidders" at this stage in the RFP process.

any potential postponement, withdrawal, or cancellation of the RFP or any portion thereof.

## **Chapter 2: Resource Needs and Requirements**

### **2.1 Performance Standards**

Proposals must meet the attributes set forth in this RFP, the technical requirements identified in Appendix I of Rule 14H, and either the requirements of the applicable RDG PPA for proposals greater than 5 MW or Mid-Tier SFC for proposals 250 kW or greater, up to and including 5 MW. This RFP, Rule 14H, and either the applicable RDG PPA or the Mid-Tier SFC set forth the minimum requirements that all Proposals must satisfy to be eligible for consideration in this RFP. If there is a conflict between the Performance Standards in Rule 14H and the applicable RDG PPA or Mid-Tier SFC, the contract terms will control. Additional Performance Standards may be required based on the results of the IRS.

2.1.1 For Paired Projects, the functionality and characteristics of the storage must be maintained throughout the term of the RDG PPA or Mid-Tier SFC. To be clear, Proposers may not propose any degradation for either capacity or efficiency in their Proposals.

2.1.2 Grid forming and black start capability<sup>9</sup> are preferred but not required.

### **2.2 System Information**

2.2.1 For Projects intending to interconnect to the Company System at the distribution level (25 kV or lower), Proposers are encouraged to use the Locational Value Maps located at <https://www.hawaiielectric.com/clean-energy-hawaii/integration-tools-and-resources/locational-value-maps> to determine circuit capacity. However, while the Locational Value Map provides information regarding an initial assessment of the potential MW hosting capacity for distribution level circuits, these numbers should only be used as a screening tool to select a circuit that will provide a higher likelihood of interconnection. This is because the methodology used to develop these hosting capacity numbers is geared towards smaller distributed energy resources (“DER”) and does not include the scenario of a larger DER interconnecting at one point. As a result, load flow analyses are required to confirm the impact to line capacities and voltage limits. Detailed load flow analyses will be performed as part of the project selection process. Prior to submitting a proposal, Proposers are encouraged to inquire about the

---

<sup>9</sup> The ability to start itself and provide power to the Company's grid without relying on any services or energy from the Company's grid in order to assist the grid in recovering from a total or partial shutdown. During such a total or partial shutdown of the grid, the Project may experience step changes in load and other transient and dynamic conditions as it picks up load without support from other resources on the grid during start-up (if the Project remains connected) or while connecting to the loads the Project is picking up (not the start-up and connecting of the Facility itself).

viability of interconnecting a proposed Project at a specific location. Please direct questions to the RFP Email Address in Section 1.6.

- 2.2.2 For Projects interconnecting to 46 kV circuits, Company information regarding an initial assessment of potential MW capacity of 46 kV circuits will be made available to Proposers only after execution of the CBRE NDA.<sup>10</sup> Proposers should perform their own evaluation of project locations, and the Company does not guarantee any project output or ability to connect based on such information. Prior to submitting a proposal, Proposers are encouraged to inquire about the viability of interconnecting a proposed Project at a specific location. Please direct questions to the RFP Email Address in Section 1.6.
- 2.2.3 For Projects interconnecting to 46 kV circuits, the proposed Project output cannot exceed the available hosting capacity limit during the daytime hours of 8am to 5pm.<sup>11</sup> The proposed Project output at all other hours (5pm to 8am) cannot exceed the identified conductor limit (less any existing or expected generation sources available during those hours prior to the GCOD). For example, a solar resource paired with storage may interconnect to a circuit with a stated hosting capacity of zero provided that no energy is exported during the hours of 8am and 5pm and the export of power does not exceed the conductor limit after 5pm. Specifically, as it pertains to interconnection to the 46 kV system, Proposers may inquire regarding the viability of upgrading 46 kV conductors to increase available capacity based on a specific location (direct questions to the RFP Email Address in Section 1.6). Prior to the RFP, developers may inquire as to viability of proposed real project locations for interconnection.
- 2.2.4 A detailed IRS, when performed, may reveal other adverse system impacts that may further limit a Project's ability to interconnect and/or further limit the net output of the Facility without upgrades.

### **2.3 Interconnection to the Company System**

- 2.3.1 The Proposer must provide all information pertaining to the design, development, and construction of the Interconnection Facilities as specified in Appendix B. Interconnection Facilities includes both: (1) Seller-Owned Interconnection Facilities; and (2) Company-Owned Interconnection Facilities.
- 2.3.2 All Proposals must include a description and conceptual or schematic diagrams of the Proposer's plan to transmit power from the Facility to the Company System. The proposed Interconnection Facilities must be compatible with the Company System. In the design, Projects must adequately consider Company requirements to address impacts on the performance and reliability of the Company System.

---

<sup>10</sup> Appendix E contains the Mutual Confidentiality and Non-Disclosure Agreement for this RFP.

<sup>11</sup> The available hosting capacity is not a final determination whether it is feasible to interconnect a Proposed Facility. The available hosting capacity provided in response to inquiries to the Company represents the power system's conditions at the time the analysis is conducted. This analysis will examine steady-state thermal capacity and voltage issues during daytime minimum loading conditions only.

- 2.3.2.1 In addition to the Performance Standards and findings of the IRS, the design of the Interconnection Facilities, including power rating, Point(s) of Interconnection with the Company System, and scheme of interconnection, must meet Company standards. The Company will provide its construction standards and procedures to the Proposer (Engineer, Procure, Construct Specifications for Hawaiian Electric Power Lines and Substations) if requested via the communication methods identified in Section 1.5 and upon the execution of a CBRE NDA as specified in Section 3.12.1. These specifications are intended to illustrate the scope of work typically required to administer and perform the design and construction of a Hawaiian Electric substation and power line.
- 2.3.2.2 Interconnection Facilities must be designed such that it meets or exceeds the applicable single line diagram in Appendix H, Attachment 1, Attachment 2, or Attachment 3.
- 2.3.3 Tariff Rule No. 19, a copy of which is attached as Appendix I, establishes provisions for Interconnection and Transmission Upgrades. The tariff provisions are intended to simplify the rules regarding who pays for, installs, owns, and operates interconnection facilities in the context of competitive bidding.
- 2.3.4 The Proposer shall be responsible for all costs required to interconnect a Project to the Company System, including all Seller-Owned Interconnection Facilities and Company-Owned Interconnection Facilities.
- 2.3.5 Proposers are required to include in their pricing proposal all costs for interconnection and equipment expected to be required between their Facility and their proposed Point of Interconnection. Appendix H includes information related to Company-Owned Interconnection Facilities and costs that may be helpful to Proposers. Selected Proposers shall be responsible for the actual final costs of all Seller-Owned Interconnection Facilities and Company-Owned Interconnection Facilities (see Appendix H), whether or not such costs exceed the costs set forth in a Proposer's Proposal. No adjustments will be allowed to the proposed price in a Proposal if actual costs for Interconnection Facilities exceed the amounts proposed.
- 2.3.6 Proposers are required to include in their pricing proposal all costs for distribution-level service interconnection for station power.
- 2.3.7 All Projects will be screened for general readiness to comply with the requirements for interconnection. Proposals selected to the Final Award Group will be subject to Section 5.1.1. Proposals selected to the Final Award Group may be subject to further study in the form of an IRS. The IRS process is further described in Section 5.1.2. The results of the completed IRS or as identified through the Detailed Evaluation process, as well as any mitigation measures identified, will be incorporated into the terms and conditions of a final executed RDG PPA or Mid-Tier SFC.



**Chapter 3: Instructions to Proposers**

**3.1 Schedule for the Proposal Process**

Table 1 sets forth the proposed schedule for the proposal process (the “RFP Schedule”). The RFP Schedule is subject to PUC approval. The Company reserves the right to revise the RFP Schedule as necessary. Changes to the RFP Schedule prior to the RFP Proposal Due Date will be posted to the RFP website. Changes to the RFP Schedule after the Proposal Due Date will be communicated via Email to the Proposers and posted on the RFP Website.

**Table 1  
Proposed RFP Schedule**

<b>Milestone</b>	<b>Schedule Dates</b>
(1) Draft RFP filed	October 9, 2020
(2) Technical Status Conference	October 28, 2020
(3) Parties and Participants file Comments by	November 13, 2020
(4) Proposed Final RFP filed	December 1, 2020
(5) Final RFP is Issued	January 8, 2021 <sup>12</sup>
(6) Self-Build Proposal Due Date	March 9, 2021 at 2:00 pm HST
(7) IPP and Affiliate Proposal Due Date	March 10, 2021 at 2:00 pm HST
(8) Selection of Priority List	May 21, 2021
(9) BAFOs Due	May 28, 2021
(10) Selection of Final Award Group	September 10, 2021
(11) Contract Negotiations Start	September 20, 2021

**3.2 Company RFP Website/Electronic Procurement Platform**

3.2.1 The Company has established a website for general information to share with potential Proposers. The RFP website is located at the following link:

[www.hawaiianelectric.com/competitivebidding](http://www.hawaiianelectric.com/competitivebidding)

The Company will provide general notices, updates, schedules and other information on the RFP website throughout the process. Proposers should check the website frequently to stay abreast of any new developments. This website will also contain the link to the Electronic Procurement Platform employed by the Company for the receipt of Proposals.

---

<sup>12</sup> Per Section IV.B.6.e.ii of the Competitive Bidding Framework “[t]he utility shall have the right to issue the RFP if the Commission does not direct the utility to do otherwise within thirty (30) days after the Commission receives the proposed RFP and the Independent Observer's comments and recommendations.” January 8, 2021 is an offered issue date that provides the Commission at least thirty (30) days to review the Proposed Final RFP drafts but shifts the Proposal development period to begin after the holiday season. However, this date and all subsequent dates in the proposed schedule are dependent on any further guidance provided by the PUC.

“Sourcing Intelligence” developed by Power Advocate is the Electronic Procurement Platform that the Company has licensed and will utilize for the receipt of Proposals in this RFP. Proposers who do not already have an existing account with PowerAdvocate and who intend to submit a Proposal for this RFP will need to register as a “Supplier” with PowerAdvocate.

- 3.2.2 There are no license fees, costs, or usage fees to Proposers for the use of the Electronic Procurement Platform.

See Appendix D for user information on and screenshots of PowerAdvocate’s Sourcing Intelligence procurement platform.

### **3.3 Information Exchange**

The PUC conducted a Technical Status Conference on October 28, 2020 to discuss the draft RFP. Parties and Participants had the opportunity to submit comments on the draft RFP. The Company then revised the RFP after considering the comments received and filed a final RFP for PUC review and approval.

Additionally, the Company will hold a prerecorded webinar for CBRE Tranche 1 in accordance with the Competitive Bidding Framework for prospective Proposers to learn about the provisions and requirements of this RFP. This prerecorded webinar will be posted to the Company’s website within one week of the issuance of the final RFP.

Prospective Proposers may also submit written questions regarding the RFP to the RFP Email Address set forth in Section 1.6. The Company will endeavor to address all questions that will be helpful to prospective Proposers via a Q&A section on the RFP website.

Prospective Proposers should review the RFP Website’s Q&A section prior to submission of their Proposal. Duplicate questions will not be answered.

### **3.4 Preparation of Proposals**

- 3.4.1 Each Proposer shall be solely responsible for reviewing the RFP (including all attachments and links) and for thoroughly investigating and informing itself with respect to all matters pertinent to this RFP, the Proposer’s Proposal, and the Proposer’s anticipated performance under the applicable RDG PPA or Mid-Tier SFC. It is the Proposer’s responsibility to ensure it understands all requirements of the RFP, to seek clarification if the RFP’s requirements or Company’s request is not clear, and to ask for any confirmation of receipt of submission of information. Under Section 1.7.5, the Proposer is solely responsible for all errors in its Proposal(s). The Company will not accept any explanation by a Proposer that it was incumbent on the Company to catch any error.
- 3.4.2 Proposers shall rely only on official information provided by the Company in this RFP when preparing their Proposal. The Company will rely only on the information included in the Proposals, and additional information solicited by the Company to Proposers in the

format requested, to evaluate the Proposals received. Evaluation will be based on the stated information in this RFP and on information submitted by Proposers in response to this RFP. Proposals must clearly state all capabilities, functionality and characteristics of the Project; must clearly detail plans to be performed; must explain applicability of information; and must provide all referenced material if it is to be considered during the Proposal evaluation. Referencing previous RFP submissions or projects for support will not be considered. Proposers should not assume that any previous RFP decisions or preferences will also apply to this RFP.

3.4.3 Each Proposer shall be solely responsible for, and shall bear all of its costs incurred in the preparation of its Proposal and/or its participation in this RFP, including, but not limited to, all costs incurred with respect to the following: (1) review of the RFP documents; (2) status conference participation; (3) site visits; (4) third-party consultant consultation; and (5) investigation and research relating to its Proposal and this RFP. The Company will not reimburse any Proposer for any such costs, including the selected Proposer(s).

3.4.4 Each Proposal must contain the full name and business address of the Proposer and must be signed by an authorized officer or agent<sup>13</sup> of the Proposer.

### **3.5 Organization of the Proposal**

The Proposal must be organized as specified in Appendix B. It is the Proposer's responsibility to ensure the information requested in this RFP is submitted and contained within the defined proposal sections as specified in Appendix B.

### **3.6 Proposal Limitations**

Proposers expressly acknowledge that Proposals are submitted subject to the following limitations:

The RFP does not commit or require the Company to award a contract, pay any costs incurred by a Proposer in the preparation of a Proposal, or procure or contract for products or services of any kind whatsoever. The Company reserves the right, in consultation with the Independent Observer, to accept or reject, in whole or in part, any or all Proposals submitted in response to this RFP, to negotiate with any or all Proposers eligible to be selected for award, or to withdraw or modify this RFP in whole or in part at any time.

- The Company reserves the right, in consultation with the Independent Observer, to request additional information from any or all Proposers relating to their Proposals or to request that Proposers clarify the contents of their Proposals. Proposers who

---

<sup>13</sup> Proposer's officer or agent must be authorized to sign the Proposal. Such authorization must be in writing and may be granted via Proposer's organizational documents (i.e., Articles of Incorporation, Articles of Organization, By-laws, etc.), resolution, or similar documentation.

are not responsive to such information requests may be eliminated from further consideration upon consultation with the Independent Observer.

- The Company reserves the right, in consultation with the Independent Observer, to solicit additional Proposals from Proposers after reviewing the initial Proposals. Other than as provided in this RFP, no Proposer will be allowed to alter its Proposal or add new information to a Proposal after the Proposal Due Date.
- All material submitted in response to this RFP will become the sole property of the Company, subject to the terms of the CBRE NDA.

### **3.7 Proposal Compliance and Bases for Disqualification**

Proposers may be deemed non-responsive and/or Proposals may not be considered for reasons including, but not limited to, the following:

- Any unsolicited contact by a Proposer or prospective Proposer with personnel of the Company pertaining to this RFP as described in Section 1.5.5.
- Any illegal or undue attempts by or on behalf of the Proposer or others to influence the Proposal Review process.
- The Proposal does not meet one or more of the Eligibility Requirements specified in Section 4.2.
- The Proposal does not meet one or more of the Threshold Requirements specified in Section 4.3.
- The Proposal is deemed to be unacceptable through a fatal flaws analysis as described in Section 4.4.2.
- The Proposer does not respond to a Company request for additional information to clarify the contents of its Proposal within the timelines specified by the Company.
- The Proposal contains misrepresentations or errors.

### **3.8 Power Purchase Agreement**

3.8.1 The Power Purchase Agreement for proposals selected under this RFP that are greater than 5 MW in size will be in the form of the RDG PPA, attached as Appendix K and Appendix M.

3.8.2 The Power Purchase Agreement for proposals selected under this RFP that are 250 kW or larger, up to and including 5 MW in size, will be in the form of a pre-approved Mid-Tier SFC, attached as Appendix L and Appendix N. The Mid-Tier SFC will be reviewed and pre-approved by the PUC and as a result, will not be negotiable.

- 3.8.3 If selected, any Affiliate Proposers will be required to enter into the applicable RDG PPA or Mid-Tier SFC with the Company.
- 3.8.4 If selected, a Self-Build Proposer will not be required to enter into a RDG PPA or Mid-Tier SFC with the Company. However, the Self-Build Proposer will be held to the proposed modifications to the RDG PPA, if any, it submits as part of the SBO in accordance with Section 3.8.6. Moreover, the SBO will be held to the same performance metrics and milestones set forth in the applicable RDG PPA or Mid-Tier SFC to the same extent as all Proposers, as attested to in the SBO's Appendix G Attachment 1, Self-Build Option Certification submittal. If liquidated damages are assessed, they will be paid from shareholder funds and returned to customers through the Purchased Power Adjustment Clause ("PPAC") or other appropriate rate adjustment mechanisms.

To retain the benefits of operational flexibility for a Company-owned facility, the SBO Proposal will be permitted to adjust operational requirements and performance metrics with the approval of the PUC. The process for adjustment would be similar to a negotiated amendment to a PPA with PUC approval.

- 3.8.5 In general, under the RDG PPA and Mid-Tier SFC, payment to the Seller consists of a Lump Sum Payment component to cover the costs of the Project. For wind projects only, the Company will allow developers to also include an additional Price for Purchase of Electric/Renewable Energy component (\$/MWh component) to cover variable operations and maintenance costs that cannot be captured within the Lump Sum Payment component. In return for the Lump Sum Payment component, the Seller shall guarantee minimum performance and availability metrics to ensure that the Facility is maintained and available for energy storage (if applicable) and dispatch, as well as provide an indication of the available energy in near real-time for the Company's dispatch. Company shall not be obligated to accept, nor shall it be required to pay for, test energy generated by the Facility during acceptance testing or other test conditions.
- 3.8.6 The Performance Standards identified in Section 2.1 establish the minimum requirements a Proposal must satisfy to be eligible for consideration in this RFP. A proposed Facility's ability to meet these Performance Standards is both a Threshold Requirement and a Non-Price Related Criteria under Sections 4.3 and 4.4.2, respectively. As such, these Performance Standards are non-negotiable by a Self-Build Proposer or any other Proposer. Proposers may propose modifications to other sections of the RDG PPA but are encouraged to accept such terms as written in order to expedite the overall RFP process and potential contract negotiations. As a component of their respective Proposals, a Self-Build Proposer or any other Proposer who elects to propose modifications shall provide a Microsoft Word red-line version of the relevant document identifying specific proposed modifications to the model language that the Proposer is agreeable to, as well as a detailed explanation and supporting rationale for each modification.
- 3.8.6.1 General comments, drafting notes and footnotes such as "parties to discuss," and reservation of rights to propose modifications at a later time, are unacceptable and will be considered non-responsive. Proposed modifications to the RDG PPA will be evaluated

as a non-price evaluation criterion as further described in Section 4.4.2. In order to facilitate this process, the Company will make available electronic versions of the model agreements on the RFP website and through the Electronic Procurement Platform for the RFP. Any proposed modifications to the RDG PPA will be subject to negotiation between the Company and the Final Award Group and should not be assumed to have been accepted either as a result of being selected to the Final Award Group or based on any previously executed PPA. As stated above, since general comments, drafting notes, and footnotes without accompanying specific proposed language modifications are unacceptable and non-responsive, the Company will not negotiate provisions simply marked by such general comments, drafting notes, and footnotes.

3.8.6.2 The Company has an interest in maintaining consistency for certain provisions of the RDG PPAs, such as the calculation of availability and payment terms. Therefore, for such provisions, the Company will endeavor to negotiate similar and consistent language across PPAs for the Final Award Group.

3.8.7 Proposals that do not include specific proposed modifications to the attached RDG PPAs will be deemed to have accepted the RDG PPA in its entirety.

### **3.9 Pricing Requirements**

3.9.1 Proposers must submit pricing for each of their variations associated with each Proposal (if variations as described in Section 1.8.2 and 1.8.3 are submitted). Proposers are responsible for understanding the terms of the applicable RDG PPA or Mid-Tier SFC. Pricing cannot be specified as contingent upon other factors (e.g., changes to federal tax policy or receiving all Investment Tax Credits assumed).

3.9.2 Escalation in pricing over the term of the RDG PPA or the term of the Mid-Tier SFC is prohibited.

3.9.3 Pricing information must only be identified within specified sections of the Proposal as instructed by this RFP's Appendix B Proposer's Response Package (i.e., Proposal pricing information must be contained within defined Proposal sections of the Proposal submission). Pricing information contained anywhere else in a Proposal will not be considered during the evaluation process.

3.9.4 The Proposer's Response Package must include the following prices for each Proposal (and variation):

For IPP or Affiliate proposals:

- **Lump Sum Payment (\$/year):** Payment amount for full dispatchability of the Facility. Payment will be made in monthly increments.
- **(Optional, For Wind Projects Only) Price for Purchase of Electric/Renewable Energy (\$/MWh):** Payment for delivery of net energy sourced from the variable

generation resource, if desired. No Energy Payment will be provided for any energy delivery that is sourced originally from the grid (Company's System).

For Self-Build Proposals:

- **Total Project Capital Costs (\$/year):** Total capital costs for the project (identified by year).
- **Annual O&M Costs (\$/year):** Initial year operations and maintenance costs, annual escalation rate.
- **Annual Revenue Requirement (\$/year):** Annual revenue requirements (ARR) calculated for each year.

See Appendix G for descriptions and detail on the Total Project Capital Costs, Annual O&M Costs, and Annual Revenue Requirement for the Self-Build Proposals.

- 3.9.5 As identified in the Schedule of Defined Terms in the PPA under "BESS Allocated Portion of the Lump Sum Payment", the allocated portion of the Lump Sum Payment specified for energy storage for the Facility for determining liquidated damages is 50% and shall be a non-negotiable percentage in the PPA.

### 3.10 Project Description

- 3.10.1 Proposals are required to provide a NEP RFP Projection for the Project. The NEP RFP Projection associated with the proposed Project represents the estimated annual net energy (in MWh) that could be produced by the Facility and delivered to the Point of Interconnection over a ten-year period with a probability of exceedance of 95%. For Paired Projects, the energy generated by the Facility in excess of Company dispatch but below the Facility's Allowed Capacity that is stored in the Facility's energy storage component and can later be discharged to the POI considering the BESS Contract Capacity and Maximum Rated Output should be included in the NEP RFP Projection. Any energy in excess of what is allowed to be delivered to the POI and would exceed the BESS Contract Capacity shall be excluded from the Net Energy Potential. To achieve this objective, the BESS Contract Capacity (MWh) must be at least four times the MW Capacity of the installed PV or wind Capacity. Any energy generated outside of the proposed Facility that is used to charge the energy storage component should not be factored into the NEP RFP Projection. Any losses that may be incurred from energy being stored and then discharged from the energy storage (round trip efficiency losses) should be excluded from the NEP RFP Projection, but the NEP should consider auxiliary loads in developing the value relative to the POI. The NEP RFP Projection will be used

in the RFP evaluation process and therefore Proposers will be held to their provided value.<sup>14</sup>

- 3.10.2 Paired Project Proposals are required to provide a single value Round Trip Efficiency (“RTE”), measured at the Point of Interconnection, that the Facility’s BESS component is required to maintain throughout the term of the RDG PPA or Mid-Tier SFC. This RTE value will be used in the RFP evaluation process and therefore Proposers will be held to this provided value as it will become the RTE Performance Metric in Section 2.10 of the RDG PPA or Mid-Tier SFC. Please review the model PPA for potential liquidated damages assessed against Seller if the BESS does not maintain the required RTE. The RTE is further specified in Appendix B Section 2.
- 3.10.3 Each Proposer must also agree to provide Project financial information, including proposed Project finance structure information specified in Appendix B. Such information will be used to evaluate Threshold Requirements and non-price criteria (e.g., Financial Viability of Proposer, Financial Strength and Financing Plan, State of Project Development and Schedule) set forth in Sections 4.3 and 4.4.2. Upon selection, the Final Award Group may be requested to provide further detailed cost information if requested by the PUC or the Consumer Advocate as part of the PPA approval process. If requested, such information would be provided to the PUC, Consumer Advocate, and Company pursuant to a protective order in the docket.
- 3.10.4 The Proposer agrees that no material changes or additions to the Facility from what is submitted in its Proposal will be made without the Proposer first having obtained prior written consent from the Company. Evaluation of all Proposals in this RFP is based on the information submitted in each Proposal at the Proposal Due Date. If any Proposer requests any Proposal information to be changed after that date, the Company, in consultation with the Independent Observer, and in consideration of whether the evaluation is affected, will determine whether the change is permitted.

### **3.11 Sites Identified by the Company**

- 3.11.1 As an alternative to a Site identified by the Proposer, the Company has identified potential Sites where landowners have expressed a willingness to negotiate a lease or purchase of the land to support a renewable energy project. These Sites were identified through a Land RFI. Proposers will be responsible for working directly with the landowner and must secure Site Control with such landowner prior to submitting a Proposal. Land RFI information is available to interested parties who sign the CBRE NDA. The Land RFI is further described in Appendix F.

---

<sup>14</sup> If a Proposal is selected to the Final Award Group and a RDG PPA or Mid-Tier SFC is executed between the Company and the Proposer, the NEP RFP Projection will be further evaluated at several steps throughout the process as set forth in the RDG PPA or Mid-Tier SFC, and adjustments to the Lump Sum Payment will be made accordingly. Additionally, because the Company will rely on an accurate representation of the NEP RFP Projection in the RFP evaluation, a one-time liquidated damage as described in the RDG PPA or Mid-Tier SFC will be assessed if the First NEP benchmark is less than the Proposer’s NEP RFP Projection. After the Facility has achieved commercial operations, the performance of the Facility will be assessed on a continuing basis against key metrics identified in the RDG PPA or Mid-Tier SFC. See Article 2 and Attachment U of the RDG PPA or the Mid-Tier SFC.



Proposers are not required to select a Site identified in the Land RFI and as noted above may propose any Site for a Project.

### **3.12 Confidentiality**

- 3.12.1 Each prospective Proposer must submit an executed CBRE NDA in the form attached as Appendix E by the Proposal Due Date specified in the RFP Schedule in Section 3.1, Table 1, Item 7. The form of the CBRE NDA is not negotiable. Information designated as confidential by the Company will be provided on a limited basis, and only those prospective Proposers who have submitted an executed CBRE NDA will be considered. NDAs that were fully executed for prior non-CBRE RFPs will not be accepted. Proposers must clearly identify all confidential information in their Proposals. However, Proposers should designate as confidential only those portions of their Proposals that genuinely warrant confidential treatment. The Company discourages the practice of marking every page of a Proposal as confidential. The Company will make reasonable efforts to protect any such information that is clearly marked as confidential. Consistent with the terms of the CBRE NDA, the Company reserves the right to share any information, even if marked confidential, to its agents, contractors, or the Independent Observer for the purpose of evaluating the Proposal and facilitating potential contract negotiations.
- 3.12.2 Proposers, in submitting any Proposal(s) to Company in response to this RFP, certify that such Proposer has not shared its Proposal(s), or any part thereof, with any other Proposer of a Proposal(s) responsive to this RFP.
- 3.12.3 The Company will request that the PUC issue a Protective Order to protect confidential information provided by Proposers to the Company and to be filed in a proceeding before the PUC. A copy of the Protective Order, once issued by the PUC, will be provided to Proposers. Proposers should be aware that the Company may be required to share certain confidential information contained in Proposals with the PUC, the State of Hawai‘i Department of Commerce and Consumer Affairs, Division of Consumer Advocacy, and the parties to any docket instituted by the PUC, provided that recipients of confidential information have first agreed in writing to abide by the terms of the Protective Order. Notwithstanding the foregoing, no Proposer will be provided with Proposals from any other Proposer, nor will Proposers be provided with any other information contained in such Proposals or provided by or with respect to any other Proposer.

### **3.13 Credit Requirements**

- 3.13.1 Proposers with whom the Company enters into an RDG PPA or Mid-Tier SFC must post Development Period Security and Operating Period Security in the form of an irrevocable standby letter of credit from a bank chartered in the United States as required and set forth in Article 14 of the RDG PPA or the Mid-Tier SFC. Cash, a parent guaranty, or other forms of security will not be accepted in lieu of the irrevocable standby letter of credit.

- 3.13.2 The Development Period Security and Operating Period Security identified in the RDG PPA or the Mid-Tier SFC are minimum requirements. Proposers shall not propose an amount lower than that set forth in the RDG PPA or the Mid-Tier SFC.
- 3.13.3 Each Proposer shall be required to provide a satisfactory irrevocable standby letter of credit in favor of the Company from a bank chartered in the United States to guarantee Proposer's payment of interconnection costs for all Company-Owned Interconnection Facilities in excess of the Total Estimated Interconnection Costs and/or all relocations costs in excess of Total Estimated Relocation Costs that are payable to Company as required and set forth in Attachment G to the RDG PPA or the Mid-Tier SFC.
- 3.13.4 Proposers may be required to provide an irrevocable standby letter of credit in favor of the Company from a bank chartered in the United States in lieu of the required Source Code Escrow in an amount and as required and set forth in Attachment B to the RDG PPA or Mid-Tier SFC.

## **Chapter 4: Evaluation Process and Evaluation Criteria**

### **4.1 Proposal Evaluation and Selection Process**

The Company will employ a multi-step evaluation process. Once the Proposals are received, the Proposals will be subject to a consistent and defined review, evaluation, and selection process. This Chapter provides a description of each step of the process, along with the requirements of Proposers at each step. Figure 1 sets forth the flowchart for the proposal evaluation and selection process.

Upon receipt of the Proposals, the Company will review each Proposal submission to determine if it meets the Eligibility Requirements and the Threshold Requirements. The Company, in coordination with the Independent Observer will determine if a Proposer is allowed to cure any aspect of its Proposal or whether the Proposal would be eliminated based on failure to meet either Eligibility or Threshold Requirements.<sup>15</sup> If a Proposer is provided the opportunity to cure any aspect of its Proposal, the Proposer shall be given three (3) business days to cure from the date of notification to cure.<sup>16</sup> Proposals that have successfully met the Eligibility and Threshold Requirements will then enter a two-phase process for Proposal evaluation, which includes the Initial Evaluation resulting in the development of a Priority List, followed by the opportunity for Priority List Proposals to provide Best and Final Offers, and then a Detailed Evaluation process to arrive at a Final Award Group.

---

<sup>15</sup> As a general rule, if a Proposer does not include a requested document, inadvertently excludes minor information or provides inconsistencies in its information, it may be given a chance to cure such deficiency. If a Proposer fails to provide material required information in its Proposal and providing the Proposer an opportunity to cure is deemed by the Company, in consultation with the Independent Observer, as an unfair advantage to such Proposer, the Proposal could be classified as non-conforming and eliminated for failure to meet the Eligibility Requirements.

<sup>16</sup> The initial request will be offered three (3) business days to cure. Succeeding inquiries on the deficiencies will be offered cure periods deemed sufficient by the Company and Independent Observer.

**Figure 1 – Evaluation Workflow**

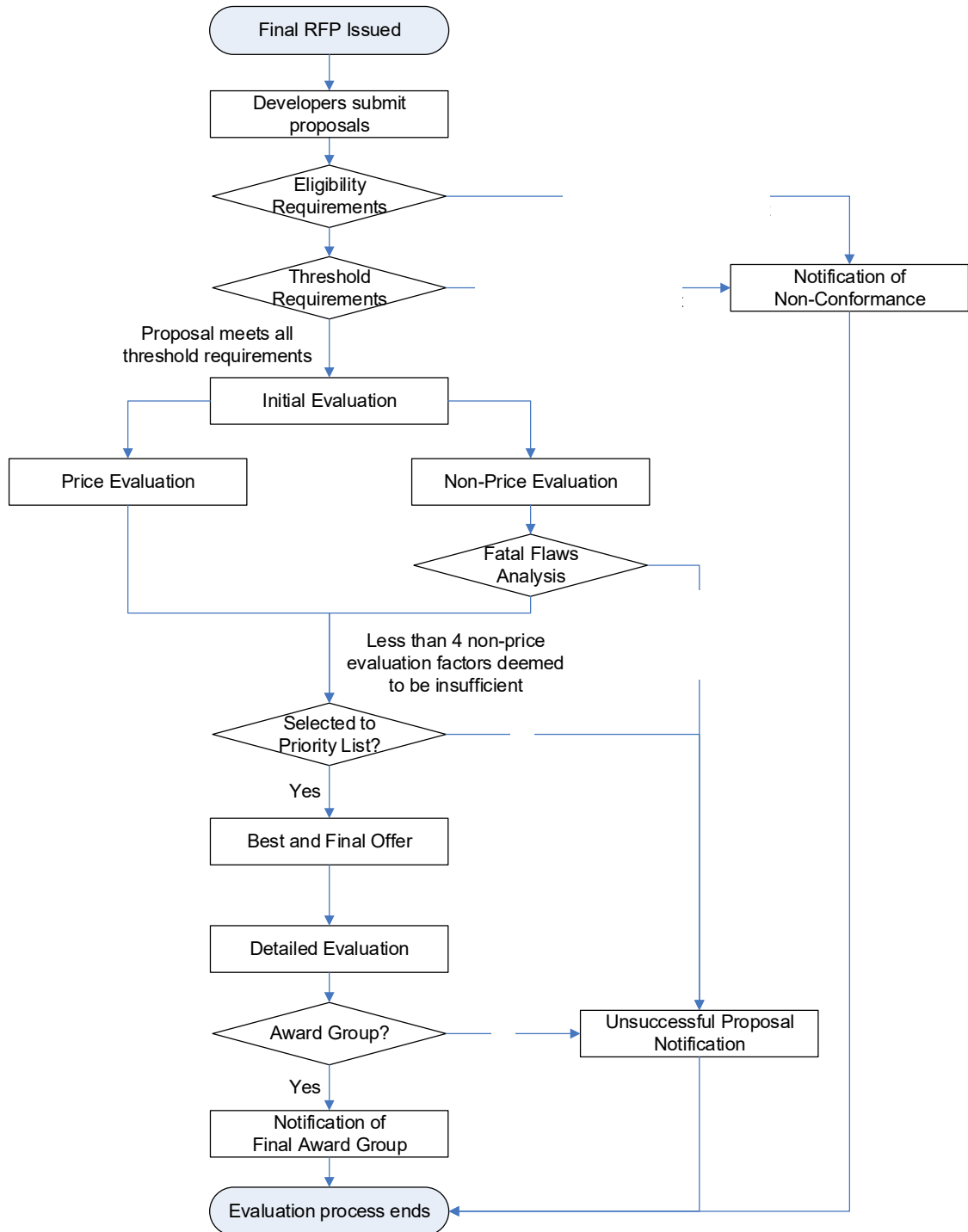

## 4.2 Eligibility Requirements Assessment

Upon receipt of the Proposals, each Proposal will be reviewed to ensure that it meets the following Eligibility Requirements.

- The Proposer is not eligible to participate in this RFP if the Proposer, its parent company, or an affiliate of the Proposer has:
  - defaulted on a current contract with the Company, or
  - had a contract terminated by the Company, or
  - any pending litigation with the Company.
- The Proposal including required uploaded files must be received on time via the Electronic Procurement Platform.
- The Proposal Fee must be received on or before the Proposal Due Date.<sup>17</sup>
- The Proposal must not contain material omissions.
- The Proposal must be signed and certified by an officer or other authorized person of the Proposer.
- The Proposer must fully execute the CBRE NDA and any other document required pursuant to this RFP.
- The Proposer must provide a Certificate of Vendor Compliance from the Hawai'i Compliance Express dated and issued within 60 days of the date of Proposal submission (a certificate of good standing from the State of Hawai'i Department of Commerce and Consumer Affairs and also federal and Hawai'i state tax clearance certificates for the Proposer may be substituted for the Certificate of Vendor Compliance).
- The Proposal must not be contingent upon changes to existing county, state, or federal laws or regulations.
- The proposed Project must be located on the island of O'ahu.
- The proposed Project must be 250 kW or larger.
- Projects interconnecting to a distribution circuit (25 kV or lower) must not exceed 3 MW.
- A minimum of 40% of the Subscriber portion of the Project must be dedicated to residential Subscribers as described in [Section 1.2.3](#).
- Project infrastructure and point of interconnection must be located outside the 3.2 feet sea level rise exposure area (SLR-XA) as described in the Hawai'i Sea Level Rise Vulnerability and Adaptation Report (2017), and not located within a Tsunami Evacuation Zone.
- The Proposal must specify a GCOD no later than March 31, 2026.
- Proposers shall agree to post Development Period Security and Operating Period Security as described in [Section 3.13](#).

## 4.3 Threshold Requirement Assessment

Proposals that meet all the Eligibility Requirements will then be evaluated to determine compliance with the Threshold Requirements, which have been designed to screen out Proposals

---

<sup>17</sup> Proposal Fees will not be required for SBO Proposals.

that are insufficiently developed, lack demonstrated technology, or will impose unacceptable execution risk for the Company.

Proposals must provide explanations and contain supporting information demonstrating how and why the Project proposed meets each of the Threshold Requirements. Proposals that fail to provide this information or meet a Threshold Requirement will be eliminated from further consideration upon concurrence with the Independent Observer.

The Threshold Requirements for this RFP are the following:

1. **Site Control:** The Proposal must demonstrate that the Proposer has Site Control for all real property required for the successful implementation of a specific Proposal at a Site not controlled by the Company, including any Interconnection Facilities, with the exception of rights-of-way or easements for the interconnection route, for which the Proposer is responsible. The need for a firm commitment is necessary to ensure that Proposals are indeed realistic and can be relied upon as the Company moves through the remainder of the RFP process. As noted in Attachment B, Section 2.5.4, while land rights are not required with the Proposal for the interconnection route, the Proposal should thoroughly describe the interconnection route and as set forth in Attachment B, Section 2.5.5, the Proposal should identify any rights-of-way or easements that are required for access to the Site or for the interconnection route and describe the plan for obtaining such rights-of-way or easement, including the proposed timeline. In addition, developmental requirements and restrictions such as zoning of the Site and the status of easements must be identified and will be considered in determining whether the Proposal meets the Site Control threshold.

To meet this Site Control requirement, Proposers must do one of the following:

- Provide documentation confirming (1) that the Proposer has an existing legally enforceable right to use and control the Site, either in fee simple or under leasehold for a term at least equal to the term of the RDG PPA or Mid-Tier SFC (“Site Control”) as specified in the Proposer’s Proposal (taking into account the timelines set forth in this RFP for selection, negotiation, and execution of a RDG PPA or Mid-Tier SFC and PUC approval as applicable), and (2) the applicable zoning for the Site and that such zoning does not prohibit the development of the Site consistent with the Proposal; or
- Provide documentation confirming, at a minimum, (1) that the Proposer has an executed binding letter of intent, memorandum of understanding, option agreement, or similar document with the land owner (a “binding commitment”) which sets forth the general terms of a transaction that would grant the Proposer the required Site Control, and (2) the applicable zoning for the Site and that such zoning does not prohibit the development of the Site consistent with the Proposal. The binding commitment does not need to be exclusive to the Proposer at the time the Proposal is submitted and may be contingent upon selection of the Proposal to the Final Award Group. If multiple Projects are provided a binding commitment for the same Site, the

documents granting the binding commitments must not prevent the Company from choosing the Proposal that otherwise would have been selected.

- **Government/Public Lands Only:** The above two bullet points may not be feasible where government or publicly-owned lands are part of the Site or are required for the successful implementation of the Proposal. In such a case, at a minimum the Proposer must provide a credible and viable plan, including evidence of any steps taken to date, to secure all necessary Site Control for the Proposal, including but not limited to evidence of sufficient progress toward approval by the government agency or other body vested with the authority to grant such approval (as demonstrated by records of the agency). The Proposer will still be required, however, to demonstrate Site Control as required in the applicable RDG PPA or Mid-Tier SFC should the Proposal be selected to the Final Award Group.
2. **Performance Standards:** The proposed Facility must be able to meet the performance attributes identified in this RFP and the Performance Standards identified in Section 2.1 of this RFP. Proposals should include sufficient documentation to support the stated claim that the Facility will be able to meet the Performance Standards. The Proposal should include information required to make such a determination in an organized manner to ensure this evaluation can be completed within the evaluation review period.
  3. **Proven Technology:** This criterion is intended as a check to ensure that the technology proposed is viable and can reasonably be relied upon to meet the objectives of this RFP. The Company will only consider Proposals utilizing technologies that have successfully reached commercial operations in commercial applications (i.e., a PPA) at the scale being proposed. Proposals should include any supporting information for the Company to assess the commercial and financial maturity of the technology being proposed.
  4. **Experience of the Proposer:** The Proposer, its affiliated companies, partners, and/or contractors and consultants on the Proposer's Project team must have experience in financing, designing, constructing, interconnecting, owning, operating, and maintaining at least one (1) electricity generation project, including all components of the project (i.e., storage or other attributes), similar in size, scope, technology, and structure to the Project being proposed by Proposer. The Company will consider a Proposer to have reasonably met this Threshold Requirement if the Proposer can provide sufficient information in its Proposal's RFP Appendix B Section 2.13 tables demonstrating that at least one member of the Proposer's team (identified in the Proposal) has specific experience in each of the following categories: financing, designing, constructing, interconnecting, owning, operating, and maintaining projects similar to the Project being proposed.
  5. **Financial Compliance:** The proposed Project must not cause the Company to be subject to consolidation, as set forth in Financial Accounting Standards Board ("FASB") Accounting Standards Codification Topic 810, Consolidation ("ASC

810”), as issued and amended from time to time by FASB. Proposers are required to state to the best of their knowledge, with supporting information to allow the Company to verify such conclusion, that the Proposal will not result in the Seller under the PPA being a Variable Interest Entity (“VIE”) and result in the Company being the primary beneficiary of the Seller that would trigger consolidation of the Seller’s finances on to the Company’s financial statements under FASB ASC 810. The Company will perform a preliminary consolidation assessment based on the Proposals received. The Company reserves the right to allow a Proposal to proceed through the evaluation process through selection of the Priority List and work with the Proposer on this issue prior to or during PPA negotiations. The Company has determined that for purposes of FASB ASC 842, a generation plus storage facility will be treated as two separate measurements of account. For accounting purposes, the energy storage portion (if applicable) will be treated as a lease, while the generation facility will not. As a result, no lease evaluation will be completed as part of the Proposal evaluation.

6. **Community Outreach:** Gaining community support is an important part of a Project’s viability and success. A comprehensive community outreach and communications plan (“Community Outreach Plan”) is an essential roadmap that guides a developer as they work with various communities and stakeholders to gain their support for a Project. Proposers must include a Community Outreach Plan that describes the Proposer’s commitment to work with the neighboring community and stakeholders and to provide them timely Project information during all phases of the Project. The Community Outreach Plan shall include, but not be limited to, the following information: Project description, community scoping (including stakeholders and community concerns), Project benefits, government approvals, development process (including Project schedule), and a comprehensive communications plan.
7. **Cultural Resource Impacts:** Proposers need to be mindful of the Project’s potential impacts to historical and cultural resources. Proposers must identify: (1) valued cultural, historical, or natural resources in the area in question, including the extent to which traditional and customary native Hawaiian rights are exercised in the area; (2) the extent to which those resources – including traditional and customary native Hawaiian rights – will be affected or impaired by the proposed action; and (3) the feasible action, if any, to be taken to reasonably protect any identified cultural, historical, or natural resources in the area in question, and the reasonable protection of traditional and customary native Hawaiian rights in the affected area. Also, Proposers must have already contracted with a consultant with expertise in this field to begin a cultural impact assessment for the Project.
8. **Available Circuit Capacity:** This criterion will only be applied to proposed Projects that intend to interconnect to Company’s 46 kV system. The output capacity of the proposed Project must not exceed the available capacity of the 46 kV circuit to which it will interconnect, except in cases where the Proposer will bear the cost of 46 kV transmission conductor upgrade as noted in Section 2.2.3.

#### 4.4 Initial Evaluation – Price and Non-Price Analysis

Proposals that meet both the Eligibility and Threshold Requirements are Eligible Proposals which will then be subject to a price and non-price assessment. Two teams have been established to undertake the Proposal evaluation process: a Price Evaluation Team and Non-Price Evaluation Team. The results of the price and non-price analysis will be a relative ranking and scoring of all Eligible Proposals. Price-related criteria will account for fifty-one percent (51%) of the total score and non-price-related criteria will account for forty-nine percent (49%) of the total score. The non-price criteria and methodology for applying the criteria are explained in [Section 4.4.2](#).

The Company will employ a closed-bidding process for this solicitation in accordance with [Part IV.H.3](#) of the Framework where the price and non-price evaluation models to be used will not be provided to Proposers. However, the Company will provide the Independent Observer with all necessary information to allow the Independent Observer to understand the evaluation models and to enable the Independent Observer to observe the entire analysis to ensure a fair process.

##### 4.4.1 Initial Evaluation of the Price Related Criteria

For the initial price analysis, an avoided cost screening approach will be used to rank proposals. Using the forecast and planning assumptions developed for the Company's Integrated Grid Planning process and evaluation methodology proposed in the Solution Evaluation & Optimization Working Group, a resource portfolio will be developed using a capacity expansion model to identify proxy resources that serve the grid needs and inform their marginal avoided costs. For each Proposal, the avoided cost of each grid service would be multiplied by the expected ability of the Proposal to provide that service or others, and summed across the services to determine the potential benefit of the Proposal. The benefit would then be reduced by the Proposal cost and normalized by the Net Energy Potential ("NEP") provided in the Proposal to calculate a Levelized Benefit ("LB") (\$/MWh).

The Company will conduct the comparative evaluation and award evaluation points to Proposals in accordance with the relative ranking based on LB. The Eligible Proposal with the highest LB will receive 510 points. All other Eligible Proposals will receive points based on a proportionate reduction using the percentage by which the Eligible Proposal's LB is lower than the highest LB. For example, if a Proposal's LB is ten percent (10%) lower than the highest LB, the Proposal will be awarded 459 points (that is, 510 points less 10%). The result of this assessment will be a ranking and scoring of the Proposals.

##### 4.4.2 Initial Evaluation of the Non-Price Related Criteria

For the non-price analysis, each Proposal will be evaluated on each of the twelve (12) non-price criteria categories set forth below:



1. Community Outreach
2. State of Project Development and Schedule
3. Performance Standards
4. Locational Value: Non-Wires Alternative (NWA) and Community Resilience
5. Commitment to Residential Subscriber Participation
6. CBRE Program
7. Environmental Compliance and Permitting Plan
8. Experience and Qualifications
9. Financial Strength and Financing Plan
10. RDG PPA Contract Proposed Modifications
11. Guaranteed Commercial Operations Date
12. Cultural Resource Impacts

Each of the first six criteria – Community Outreach, State of Project Development and Schedule, Performance Standards, Locational Value: NWA and Community Resilience, Commitment to Residential Subscriber Participation, and CBRE Program – will be weighted twice as heavily as the others to reflect the impact these categories have to achieve a successful and timely procurement. The non-price criteria are generally scored on a scale of 1 (poor) to 5 (highly preferable). A score of 3 means that a Proposal meets the minimum standard for that criteria.

The total non-price score will be the sum of the scores for each of the individual non-price criteria. The Company will then award non-price evaluation points in accordance with the relative ranking of scores. The Proposal with the highest total non-price score will receive 490 points, and all other Proposals will receive points equal to the Proposal's score divided by the top score, multiplied by 490.

During the non-price criteria evaluation, a fatal flaws analysis will also be conducted such that any Proposal that is deemed not to meet the minimum standards level for four (4) or more non-price criteria will be disqualified given that the Proposal has failed to meet the required number of non-price factors that are indicative as to the general feasibility and operational viability of a proposed Project. Non-price criteria number 4, 5 and 11 above will be excluded from the fatal flaws analysis.

The Company's evaluation of the non-price criteria will be based on the materials provided by a Proposer in its Proposal. Acceptance of any Proposal into the Final Award Group shall not be assumed or construed to be an endorsement or approval that the materials provided by Proposer are complete, accurate or in compliance with applicable law. The Company assumes no obligation to correct, confirm, or further research any of the materials submitted by Proposers. Proposers retain sole responsibility to ensure their Proposals are accurate and in compliance with all laws.

The non-price criteria are:

1. **Community Outreach** – Gaining community support is an important part of a Project's viability and success. An effective Community Outreach Plan will call for early meaningful communications with stakeholders and will reflect a deep

understanding and respect for the community's desire for information to enable them to make informed decisions about future projects in their communities. Therefore, Proposals will be evaluated on the quality of the Community Outreach Plan to inform the Project's impacted communities.

Proposals should include a Community Outreach Plan that describes the Proposer's commitment to work with the neighboring community and stakeholders and to provide timely Project information during Project development, construction and operation. The Community Outreach Plan shall include, but not be limited to the following:

- 1) Project description. A thorough description including a map of the location of the Project. This information will help the community understand the impact that the Project may have on the community.
- 2) Community scoping. Identify stakeholders (individuals, community leaders, organizations), community issues and concerns, and community sentiment.
- 3) Project benefits. An explanation of the need for the Project. This will help the community to understand how the Project might benefit their community.
- 4) Government approvals. Required government permits and approvals, public hearings and other opportunities for public comment. This information will help the community to understand the level of public scrutiny and participation that might occur for the Project and the opportunities to provide public comments.
- 5) Development process. A Project schedule that identifies key milestones will facilitate the community's understanding of the development process.
- 6) Communications Plan. A communications plan including a detailed community outreach schedule that will keep the affected communities and stakeholders informed about the Project's outreach efforts during early Project development period through construction and operations.

Preference will be given to Proposers who have already identified established contacts to work with the local community, have used community input to incorporate changes to the final design of the Project and mitigate community concerns, have proposed a community benefits package (including details of the community recipients and benefits package), or have community consultants as part of the Project team doing business in Hawai'i that have successfully worked with communities in Hawai'i on the development of two or more energy projects or projects with similar community issues. These criteria are aligned with the Company's community engagement expectation whereby all developers will be required to engage in community outreach prior to signing a PPA with the Company. This process is also outlined in RFP Section 5.3. Further information and instructions regarding expectations for the Community Outreach Plan are included as Attachment 4 and 5 to Appendix B.

2. **State of Project Development and Schedule** – Projects that are further along in development generally have lower project execution risk and a greater probability of being able to be successfully placed into service prior to the GCOD (specifically identified in each Proposal). At a minimum, Projects should demonstrate how they plan to capture any ITC safe harbor and reach their GCOD specified, including identification of risks and schedule assumptions. (Schedules must identify the IRS completion date and PUC approval dates assumed.) Proposals should also demonstrate, via a detailed critical path schedule, that there is a high likelihood that the Project will be able to reach commercial operations as specified. Proposals shall include a Gantt chart that clearly illustrates the overall schedule and demonstrates achievement of any ITC safe harbor, if applicable, and commercial operations by their specified GCOD. The Gantt chart shall include task durations and dependencies, identify tasks that will be fast tracked, and identifies slack time and contingencies. This criterion will also look at the high-level Project costs set forth in the Proposal including: costs for equipment, construction, engineering, Seller-Owned Interconnection Facilities, Company-Owned Interconnection Facilities, land, annual O&M, the reasonableness of such costs and the assumptions used for such costs. Project costs that do not appear reasonable for a project of the size proposed may result in a lower ranking for this criterion if the Company reasonably determines that the cost information is unrealistic based on prior experience in the market which may result in a risk that the Project can be built on time and for the price proposed by the Proposer. The Company reserves the right to discuss any cost and financial information with a Proposer to ensure the information provided is accurate and correct.
3. **Performance Standards** – The proposed Facility must be able to meet the performance attributes identified in this RFP and the Performance Standards identified in the applicable RDG PPA or Mid-Tier SFC. The Company will review the Proposal information received, including design documents and operating procedures materials provided in the Proposal, and evaluate whether the Project as designed is able to meet the Performance Standards identified in the applicable RDG PPA or Mid-Tier SFC and in this RFP. At a minimum, in addition to meeting the Performance Standards, the Proposal should include sufficient documentation, provided in an organized manner, to support the stated claim that the Facility will be able to meet the Performance Standards. The Proposal should include information required to make such a determination in an organized manner to ensure this evaluation can be completed on a timely basis. Preference will be given to Proposals that provide detailed technical and design information showing how each standard can be met by the proposed Facility. Preference will also be provided on facilities that offer additional capabilities.
4. **Locational Value: Non-Wires Alternative and Community Resilience** – The Company has identified areas on the grid where the siting of a CBRE Project would support grid needs, non-wire alternatives and/or community resilience. Non-wires alternatives have been identified for areas with grid needs. For Projects that support non-wires alternatives, the capability to grid charge is

needed to reliably meet distribution capacity needs. For Projects to support community resilience, storage with grid-forming and black start capability is needed for the purposes of being able to energize any proposed community or “island” as a microgrid from a de-energized state. The black start capability is not needed to energize the entire grid. Proposals should provide a description of the critical infrastructure or community resilience hubs in proximate location to the proposed Project site that could benefit from the islanding capabilities of the proposed Project. Proposers are encouraged to and will be scored more favorably for locating projects in the following:

- Areas where the grid needs that are identified in Appendix O have a higher certainty rating. Distribution Grid Needs can also be found on the Company’s Locational Value Map: [https://www.hawaiianelectric.com/clean-energy-hawaii/integration-tools-and-resources/locational-value-maps/oahu-locational-value-map-\(lvm\)](https://www.hawaiianelectric.com/clean-energy-hawaii/integration-tools-and-resources/locational-value-maps/oahu-locational-value-map-(lvm))
  - Areas with identified community resilience that are more vulnerable to extended outages are:
    - O’ahu: Ko’olaupoko moku
5. **Commitment to Residential Subscriber Participation** – Proposals will be evaluated on the stated commitments of the Project’s Subscriber Organization to residential Subscribers. At a minimum, Subscriber Organizations will be required to set aside 40% of the Project’s capacity for residential Subscribers. Proposers that commit to reserving a portion larger than 40% of their Project capacity for residential Subscribers will be given more favorable scoring. In addition, Proposals will also be evaluated on the stated commitments of the Project’s Subscriber Organization to LMI Customers. Proposers that commit to reserving a portion of the Project’s capacity for LMI Customers will be given more favorable scoring.
6. **CBRE Program** – Proposals will be evaluated on several facets of the CBRE program being proposed.
- 1) **Program Offering:** Proposals will be evaluated to give preference to program offerings that provide the most benefits to residential and LMI Customers, as applicable. Financing options, upfront fees, payment over time, public funding options, and other creative approaches will be preferred along with programs that offer higher expected customer level savings, favorable payback periods and mechanisms, and other customer benefits. In addition, Proposals shall describe the extent to which residential Subscribers will be financially responsible for the Facility’s underperformance.

- 2) **Marketing and Outreach Plans:** Proposals will be evaluated on the proposed strategies and methods to educate, inform, and stimulate the market in order to achieve their target levels of participation.
  - 3) **Program Experience:** Proposals will also be evaluated on Proposers documented success in reaching and retaining participation of residential and LMI Customers, as applicable, in other community-based renewable energy programs.
7. **Environmental Compliance and Permitting Plan** – This criterion relates to the potential (short- and long-term) environmental impacts associated with each project, the quality of the plan offered by the Proposer to mitigate and manage any environmental impacts (including any pre-existing environmental conditions), and the plan of Proposers to remain in environmental compliance over the term of the contract. These impacts are reflected on a technology-specific basis. Completing any necessary environmental review and obtaining the required permitting in a timely manner is also important and Proposals will be evaluated on their plan to identify, apply for, and secure the required permits for the Project, any permitting activity that has been completed to date, including having initial discussions with the applicable regulating agencies such as U.S. Fish and Wildlife and the State of Hawai‘i Department of Land and Natural Resources’ Division of Forestry and Wildlife, prior to submitting a Proposal, and the degree of certainty offered by the Proposer in securing the necessary permits.

At a minimum, proposed Projects should be expected to have minimal environmental impact for most areas and Proposals should provide a comprehensive plan to mitigate the identified potential or actual significant environmental impacts to remain in environmental compliance. The proposed mitigation plans should be included in the Project timeline. Preference will be given to Proposals that provide a more detailed plan as well as those that have proactively taken steps to mitigate potential environmental impacts.

Also, this criterion requires that, at a minimum, Proposers should have identified, and disclosed in their Proposal(s) all major permits, approvals, appurtenances and entitlements (including applicable access, rights of way and/or easements) (collectively, the “permits”) required and have a preliminary plan for securing such permits. Preference will be given to Proposals that are able to provide a greater degree of certainty that its plan to secure the required permits is realistic and achievable, or have already received all or a majority of the required permits. The Proposer should disclose all identified (a) discretionary permits required, i.e., those requiring public or contested case hearings and/or review and discretionary approval by an appropriate government agency and (b) ministerial conditions without discretionary approval conditions. In all cases, the Proposer must provide a credible and viable plan to secure all necessary and appropriate permits necessary for the project. For example, if the project is located within an agricultural district, the Proposer shall provide evidence of Proposer’s verification

with the appropriate government agency that the project complies with HRS Section 205-2 and Section 205-4.5, relating to solar energy facilities placed on agricultural land, provided, however that where a special use permit (under Section 205-6), exemption (under Section 205-6), or amendment to land use district boundary lines (under Section 205-4) is required to secure such compliance, Proposer shall identify the need for such permit, exemption or amendment and provide a list of required prerequisites and/or conditions and a realistic timeline necessary to obtain such permit, exemption or amendment satisfactory for Proposer to still meet its designated Guaranteed Commercial Operations Date.

8. **Experience and Qualifications** – Proposals will be evaluated based on the experience of the Proposer in financing, designing, constructing, interconnecting, owning, operating, and maintaining projects (including all components of the project) of similar size, scope and technology. At a minimum, Proposals must show via the table format specified in RFP Appendix B Section 2.13 that at least one (1) member must have specific experience in each of the following categories: financing, designing, constructing, interconnecting, owning, operating, and maintaining at least one electricity generation project including all components of the project similar to the Project being proposed. Preference will be given to Proposers with experience in successfully developing multiple projects that are similar to the one being proposed and/or that have prior experience successfully developing and interconnecting a utility scale project to the Company's System.
9. **Financial Strength and Financing Plan** – This criterion addresses the comprehensiveness and reasonableness of the financial plan for the Project as well as assesses the financial strength and capability of the Proposer to develop the Project. A complete financial plan addresses the following issues: Project ownership, capital cost and capital structure, sources of debt and equity, and evidence that credit-worthy entities are interested in financing the Project. The financial strength of Proposers or their credit support providers will be considered, including their credit ratings. The financing participants are expected to be reasonably strong financially. Developers and their sources of capital that have investment grade credit ratings from a reputable credit rating agency (S&P, Moody's, Fitch) will also be given preference, with those that have higher credit ratings ranked higher.
10. **RDG PPA Contract Proposed Modifications** – Proposers are encouraged to accept the contract terms identified in the model RDG PPA in its entirety in order to expedite the overall RFP process and potential contract negotiations. Proposers who accept the model RDG PPA without edits or utilize the Mid-Tier SFC, which is non-negotiable and cannot be marked up as part of their Proposal, will receive a higher score and will be the only proposals that can achieve the highest scoring for this non-price evaluation criterion. Technology-specific or operating characteristic-required modifications, with adequate explanation as to the

necessity of such modifications, will not jeopardize a project's ability to achieve the highest score. Proposers who elect to propose modifications to the model agreements shall provide a Microsoft Word red-line version of the applicable document identifying specific proposed modifications to the model agreement language, as well as a detailed explanation and supporting rationale for each modification. General comments without proposed alternate language, drafting notes without explanation or alternate language, footnotes such as "parties to discuss," or a reservation of rights to make additional modifications to the model agreements at a later time are unacceptable, will be considered unresponsive, and will result in a lower score. See also Section 3.8. The Company and Independent Observer will evaluate the impact that the proposed modifications will have on the overall risk assessment associated with the evaluation of each Proposal.

11. **Guaranteed Commercial Operations Date** – Proposers that are able to design for and commit to an earlier GCOD will be given more favorable scoring. Proposers will be held to the GCOD identified in their Proposal. The GCOD will be a Guaranteed Milestone and will be inserted without amendment into the RDG PPA or Mid-Tier SFC, as applicable.
12. **Cultural Resource Impacts** – Proposers need to be mindful of the Project's potential impacts to historical and cultural resources. Proposers should have identified (1) valued cultural, historical, or natural resources in the area in question, including the extent to which traditional and customary native Hawaiian rights are exercised in the area; (2) the extent to which those resources – including traditional and customary native Hawaiian rights – will be affected or impaired by the proposed action; and (3) the feasible action, if any, to be taken to reasonably protect any identified cultural, historical, or natural resources in the area in question, and the reasonable protection of traditional and customary native Hawaiian rights in the affected area.

Also, Proposers should have already contracted with a consultant with expertise in this field to begin a cultural impact assessment for the Project. Proposals will be evaluated on the Proposer's plan and commitment to addressing cultural resource impacts on their Project, if any. Therefore, in order to be evaluated for this criterion, Proposers should, at least, provide the following documentation, as applicable: (1) Proposer's or its consultant's experience with cultural resource impacts on past projects; (2) the status of their cultural impact assessment plan. Proposals will be evaluated on the extent to which their cultural impact assessment plan has been developed, and preference will be given to Proposals that are further along in the assessment process, including but not limited to, whether a mitigation/action plan has been provided that addresses any identified cultural resource issues, or a date for when such a plan will be available has been identified, or any portions of such plan have been completed.

#### 4.5 Selection of a Priority List

At the conclusion of both the price and non-price analysis, a total score will be calculated for each Proposal using the 51% price-related criteria / 49% non-price-related criteria weighting outlined above. The price and non-price analysis, and the summation of both price and non-price scores described above, will result in a ranking of Proposals.

The Company will determine a Priority List from the highest scoring Proposals. The Company will develop the Priority Lists in consultation with the Independent Observer. The Company reserves the right, in consultation with the Independent Observer, to limit the projects allowed for further consideration in the initial evaluation to projects that fall within 15% of the highest Levelized Benefit. Selection to the Priority List does not assure an eligible Project's inclusion in the selection of the Final Award Group.

#### 4.6 Best and Final Offer (BAFO)

4.6.1 The Company will solicit a Best and Final Offer from Proposers selected to the Priority List. If the SBO is selected to the Priority List, the SBO will not be eligible to provide a Best and Final Offer and the original pricing submitted in its Self-Build Proposal will be used in the Detailed Evaluation. All other Proposers selected to the Priority List will have the opportunity to update (downward only)<sup>18</sup> the pricing elements in their Proposal in order to improve the competitiveness of their Proposal prior to being further assessed in the Detailed Evaluation phase. At this point in the process, updates may only be made to the following pricing elements:

- Lump Sum Payment (\$/year) amount
- (For Wind Projects Only) Price for Purchase of Electric/Renewable Energy (\$/MWh) amount. Payment for delivery of net energy sourced from the variable generation resource. No Energy Payment will be provided for any energy delivery that is sourced originally from the grid (Company's System).

Proposers will not be allowed to increase their price<sup>19</sup> but may elect to maintain the same pricing submitted in their original Proposal. Proposers will not be allowed to make any other changes to their Proposal during the Best and Final Offer.

4.6.2 If a Proposer does not propose improvements to their pricing elements during the Best and Final Offer solicitation, the original Proposal pricing elements will be deemed its Best and Final Offer.<sup>20</sup>

---

<sup>18</sup> Proposers will only be allowed to adjust pricing elements downward. No upward adjustment to the pricing elements will be permitted or considered. All other characteristics of the Proposal and Facility capabilities must remain valid and unchanged (e.g., NEP, GCOD, etc.)

<sup>19</sup> Proposers will not be allowed to increase the pricing in their Proposals to address interconnection and/or system upgrade costs or for any other reason.

<sup>20</sup> The Company reserves the right, in consultation with the Independent Observer, to adjust the parameters of the BAFO, in the unlikely event that system needs have evolved in a way that the Proposals received do not fully address.



#### 4.7 Detailed Evaluation

The Best and Final Offers of the Priority List Proposals as well as any original Self-Build Proposals, if advanced to the Priority List, will be further assessed in the Detailed Evaluation to identify the Proposals selected to the Final Award Group.

The detailed evaluation process will consist of assessment of combinations of Proposals from the Priority List. A capacity expansion model will use the same assumptions as in the Initial Evaluation but replace the generic resource costs and performance characteristics with the specific costs and performance characteristics of the Projects. Due to computational limitations, all Proposals from the Priority List may not be evaluated simultaneously. The ranking developed in the Initial Evaluation can be used to screen the Proposals in the Detailed Evaluation to those that provide the highest potential benefit to the system. A production simulation model will then be used to provide a feasibility check on the final resource portfolio of Projects.

The evaluation will evaluate the benefits and costs of integrating the Project or combination of Projects onto the Company's System which includes:

1. The cost to dispatch the Project or combination of Projects and the energy and storage purchased;
2. The fuel cost savings (benefits) and any other direct savings (IPP savings from dispatchable fossil fuel savings, where applicable) resulting from the displacement of generation by the Priority List Proposals, including consideration of round-trip efficiencies for facilities with storage;
3. The estimated increase (or decrease) in operating cost, if any, incurred by the Company to maintain system reliability; and
4. The cost of imputed debt, if applicable.

As noted, the Company will take into account the cost of rebalancing its capital structure resulting from any debt or imputed debt impacts associated with each Proposal (including any costs to be incurred by the Company, as described above, that are necessary in implementing the Proposal). The Company proposes to use the imputed debt methodology published by S&P that is applicable to the Proposal being evaluated. S&P views long-term PPAs as creating fixed, debt-like financial obligations that represent substitutes for debt-financed capital investments in generation capacity. By adjusting financial measures to incorporate PPA-fixed obligations, greater comparability of utilities that finance and build generation capacity and those that purchase capacity to satisfy new load are achieved.

During the Detailed Evaluation and before the Proposals advance to the Final Award Group, the Company will perform load flow analyses to determine if certain Projects or combinations of Projects introduce circuit constraints that will factor into the selection process. This is to address the possibility that even though sufficient line capacity was identified for an individual Project, Projects that are in close proximity with each other

could introduce additional circuit constraints. The Projects selected must not have any additional constraints imposed based on the Load Flow Analysis to advance to the Final Award Group. However, the Company reserves the right, in consultation with the Independent Observer, to allow minor modifications (i.e., downsize project) to a Proposal to avoid such additional constraints. If such modification resulted in a reduced size of the Facility, the pricing proposed would also need to be revised. Under no circumstances would a Proposer be allowed to increase their price as a result of such minor modification.

Also in the Detailed Evaluation, other factors will be validated to ensure that the final combination of Projects provides the contemplated benefits that the Company seeks. The Company will evaluate the collateral consequences of the implementation of a combination of Projects, including consideration of the geographic diversity, resource diversity, interconnection complexity, and flexibility and latitude of operation control of the Projects.

The Company may assess additional combinations of Projects if requested by the Independent Observer and if the time and capability exist to perform such analyses.

Projects interconnecting to distribution circuits may be subject to the Technical Review process of Rule 14H. The Company may consider a Project's performance through this process in the Detailed Evaluation.

#### **4.8 Selection of the Final Award Group**

Based on the results of the Detailed Evaluation and review of the results with the Independent Observer, the Company will select a Final Award Group. Projects selected to the Final Award Group that are 250 kW or greater, up to and including 5 MW in size will execute a Mid-Tier SFC with the Company in the form of Appendix L or Appendix N. Projects larger than 5 MW will enter into RDG PPA (in the form of Appendix K or Appendix M) negotiations. All Proposers will be notified at this stage of the evaluation process whether their Proposal is included in the Final Award Group.

Selection to the Final Award Group and/or entering into contract negotiations does not guarantee execution of an RDG PPA or Mid-Tier SFC.

Further, if at any time during the evaluation process it is discovered that a Proposer's Proposal contains incorrect or misrepresented information that has a material effect on any of the evaluation processes, including selection of the Priority List or the Final Award Group, the Company reserves the right, at any time prior to submission of the PPA Application with the PUC, in consultation with the Independent Observer, to disqualify the Proposer from the RFP. If discovery of the incorrect or misrepresented information is made after the Company has filed its PUC application for approval of the PPA with the Proposer, the Company will disclose the incorrect or misrepresented information to the PUC for evaluation and decision as to whether such Proposer should be disqualified and the Company's application dismissed.

Following any removal of a proposal from the Final Award Group, either by disqualification noted immediately above, or via any other removal or withdrawal of a proposal, including failure to reach agreement to the PPA, the Company, taking into consideration the timing of such removal and the current status of the Company's needs under the RFP, in consultation with and concurrence from the Independent Observer, will review the Priority List to determine (1) if another proposal should be added to the Final Award Group; or (2) if the remaining proposals in the Final Award Group should remain unchanged.

## **Chapter 5: Post Evaluation Process**

### **5.1 Project Interconnection Process**

#### **5.1.1 Interconnection Modeling Process**

For all projects greater than or equal to 1 MW in size (regardless of whether an IRS is required), a complete package of Project Interconnection Data Request worksheets, Project single line diagram(s), models for equipment and controls, list(s) to clearly identify the components and respective files (for inverters and power plant controller), three line diagram(s) which show the Point of Interconnection, potential transformer (PT) and current transformer (CT) ratios, and details of the generating facility configuration, including relays, meters, and test switches, and complete documentation with instructions shall be submitted with each Proposal within 30 days after selection to the Final Award Group (see Section 2.11.1 of Appendix B). PSSE Generic models, PSSE User models, and ASPEN models shall be configured to represent all of the functional equipment with settings in place to comply with the Company's performance requirements. These must be checked for functionality by the Proposer or its vendors and consultants prior to submission to the Company. Similar and fully accurate PSCAD models shall be submitted in a condition that complies with the PSCAD modeling guidelines provided by the Company. Overlaid validation plots of PSSE Generic models, PSSE User models, and PSCAD models shall be submitted as described in the Project Interconnection Data Request worksheets to ensure compatible responses from each model.

If the Company determines that an IRS is not required, the Company will provide an Interconnection Modeling Letter Agreement for each selected Project greater than or equal to 1 MW in size, with a statement of required deposit for individual work for: (a) a technical model checkout for each project, and (b) any considerations that are specific to a particular project and location. After proposals and models are submitted, the Company will inspect the data packages for general completeness. For any incomplete submissions, a list of missing or non-functional items will be provided. Proposers will be given 15 Days to resolve data and modeling deficiencies. The Company, in consultation with the Independent Observer, may remove Proposals if their submission requirements are deemed incomplete for the lack of requested models and validation plots.

The technical model checkouts will be conducted first. Upon identification of any functional problems or deficiencies, corrective action shall be taken immediately and on an interactive basis so that the problems or deficiencies can be resolved within 15 Days,

including re-submission of data and updated models, or the Project shall be deemed withdrawn. At the discretion of the Company and provided that there is a demonstration of good faith action to minimize delay that would affect the schedule, a second round of model checkout and problem solving may proceed. Thereafter, any notice that a Project is deemed withdrawn for lack of completeness shall be final. Subject to consultation with the Independent Observer, failure to provide all requested material within the time(s) specified, or changes to the data provided after the due date(s), shall result in elimination from consideration.

#### 5.1.2 Interconnection Requirements Study Process

The Detailed Evaluation process or Appendix III of Rule 14H shall determine the need for an IRS. Upon notification of selection to the Final Award Group, and subject to Rule 14H, the Company will provide an IRS Letter Agreement (in lieu of an Interconnection Modeling Letter Agreement) for each selected project that will require an IRS, with a statement of required deposit for individual and prorated work as part of an IRS Scope for: (1) a System Impact Study that will involve (a) technical model checkout for each project, (b) any considerations that are specific to a particular project and location, and (c) system impact analyses of the projects as a group; and (2) a Facilities Study that includes the Interconnection cost and schedule, including cost of any required system upgrades. After proposals and models are submitted within 30 days after selection to the Final Award Group, the Company will inspect the data packages for general completeness. For any incomplete submissions, a list of missing or non-functional items will be provided. Proposers will be given 15 Days to resolve data and modeling deficiencies. The Company, in consultation with the Independent Observer, may remove Proposals if their submission requirements are deemed incomplete for the lack of requested models and validation plots.

The technical model checkouts will be conducted first. Upon identification of any functional problems or deficiencies, corrective action shall be taken immediately and on an interactive basis so that the problems or deficiencies can be resolved within 15 Days, including re-submission of data and updated models, or the Project shall be deemed withdrawn. At the discretion of the Company and provided that there is a demonstration of good faith action to minimize delay that would affect the schedule, a second round of model checkout and problem solving may proceed. Thereafter, any notice that a Project is deemed withdrawn for lack of completeness shall be final. Subject to consultation with the Independent Observer, failure to provide all requested material within the time(s) specified, or changes to the data provided after the due date(s), shall result in elimination from consideration.

Proposers shall be responsible for the cost of the IRS, under separate agreements for the System Impact Study and the Facilities Study. The overall IRS will provide information including, but not limited to, an estimated cost and schedule for the required Interconnection Facilities for a particular Project and any required mitigation measures. Proposers will be responsible for the actual final costs of all Seller-Owned Interconnection Facilities and Company-Owned Interconnection Facilities. Upon reviewing the results of the IRS, Detailed Evaluation or Technical Review process, if

required, pursuant to Rule 14H, Appendix III, Proposers will have the opportunity to declare the RDG PPA (see Section 12.4) or Mid-Tier SFC null and void in the event that the estimated interconnection costs and schedule for the Project are higher than what was estimated in the Project Proposal.

## **5.2 Contract Negotiation Process**

Within five (5) business days of being notified by the Company of its intent to enter into RDG PPA contract negotiations or execute a Mid-Tier SFC, Proposers selected for the Final Award Group will be required to indicate, in writing to the Company's primary contact for this RFP, whether they intend to proceed with their Proposals. Proposers who elect to remain in the Final Award Group will be required to keep their Proposal valid through the award period. RDG PPA contract negotiations will take place in parallel with the IRS process.

The Company intends to execute and file the PPA with the PUC for approval and later amend the PPA to include the results of the IRS.

## **5.3 Community Outreach and Engagement**

The public meeting and comment solicitation process described in this section and Section 29.21 of the RDG PPA (Community Outreach Plan) and Section 28 of the Mid-Tier SFC (Community Outreach) do not represent the only community outreach and engagement activities that can or should be performed by a Proposer.

The Company will publicly announce the Final Award Group no more than five (5) business days after the notification is given to Proposers who are selected to the Final Award Group. Selected Proposers shall not disclose their selection to the public before the Company publicly announces the Final Award Group selection.

On the next business day after the Company notifies a Proposer they were selected, each Proposer shall provide the Company with links to their Project website, which the Company will post on the Company's website. Each Proposer will launch a Project website that will go-live on the day the Company publicly announces the Final Award Group selection. Information on what should be included on the Project website is identified in Appendix B.

Within five (5) business days of notification of selection to the Final Award Group, Proposers must provide the Company with an updated comprehensive Community Outreach Plan to work with and inform neighboring communities and stakeholders and to provide them timely information during all phases of the Project. The Community Outreach Plan shall include but not be limited to the following information: Project description, Project stakeholders, community concerns and Proposer's efforts to address such concerns, Project benefits, government approvals, Project schedule, and a comprehensive communications plan. The Proposer's Community Outreach Plan shall be a public document identified on the Proposer's Project website and made available to the public upon request. As an option, Proposers may provide their updated Community Outreach Plan and website information to the Company for review and feedback. If

provided at least 30 days prior to the dates required, the Company will endeavor to review such information and provide feedback on the information before it is made available to the public. Details on the Community Outreach Plan can be found in Appendix B, Attachments 4 and 5.

Prior to the execution date of the PPA, Proposers shall also host a public meeting in the community where the proposed Project is to be located for community and neighborhood groups in and around the vicinity of the Project Site that provided the neighboring community, stakeholders and the general public with: (i) a reasonable opportunity to learn about the proposed Project; (ii) an opportunity to engage in a dialogue about concerns, mitigation measures, and potential community benefits of the proposed Project; and (iii) information concerning the process and/or intent for the public's input and engagement, including advising attendees for projects greater than 5 MW in size that they will have thirty (30) calendar days from the date of said public meeting to submit written comments to Company and/or Proposer for inclusion in the Company's submission to the PUC of its application for a satisfactory PUC Approval Order for Projects greater than 5 MW and for inclusion on the Proposer's website for Projects up to and including 5 MW. The Proposer shall collect all public comments, and then provide the Company copies of all comments received in their original, unedited form. The Proposer will post all comments with personal information redacted on its website for public review. Comments should remain on the Proposer's website for at least two years after the Commercial Operations date. If an RDG PPA is executed by the Proposer and the Company, the Company may submit any and all public comments (presented in its original, unedited form) as part of its PUC application for this Project. Proposers shall notify the public at least three weeks in advance of the meeting. The Company shall be informed of the meeting. The Company has provided Proposers with detailed instructions regarding the community meeting requirement after the selection of the Final Award Group (Attachment 4 to Appendix B). (For example, notice will be published in county or regional newspapers/media, as well as media with statewide distribution. The Proposer will be directed to notify certain individuals and organizations. The Proposer will be provided templates to use for the public meeting notices, agenda, and presentation.) Proposers must also comply with any other requirement set forth in the RDG PPA or Mid-Tier SFC relating to Community Outreach.

Following the submission of the PUC application for the Project, and prior to the date when the Parties' statements of position are to be filed in the docketed PUC proceeding for the Project, the Proposer shall provide another opportunity for the public to comment on the proposed Project. The Proposer's statement of position filed in the docket associated with the Project will contain an attachment including those comments.

The Proposer shall be responsible for community outreach and engagement for the Project, and that the public meeting and comment solicitation process described in this section do not represent the only community outreach and engagement activities that can or should be performed.

#### **5.4 Greenhouse Gas Emissions Analysis**

Proposers whose Proposal(s) are selected for the Final Award Group and are greater than 5 MW in size shall cooperate with and promptly provide to the Company and/or Company's consultant(s) upon request all information necessary, in the Company's sole and exclusive discretion, for such consultant to prepare a greenhouse gas ("GHG") emissions analysis and report in support of a PUC application for approval of the RDG PPA for the Project (the "GHG Review"). Proposers shall be responsible for the full cost of the GHG Review associated with their Project under a Greenhouse Gas Analysis Letter Agreement between the Proposer and the Company. The GHG Review is anticipated to address whether the GHG emissions that would result from approval of the RDG PPA and subsequent to addition of the Project to the Company's system are greater than the GHG emissions that would result from the operations of the Company's System without the addition of the Project, whether the cost for renewable, dispatchable generation, and/or energy storage services as applicable under the RDG PPA is reasonable in light of the potential for GHG emissions, and whether the terms of the RDG PPA are prudent and in the public interest in light of its potential hidden and long-term consequences.

#### **5.5 PUC Approval**

Any signed RDG PPA resulting from this RFP, greater than 5 MW in size, is subject to PUC approval as described in the RDG PPA, including Article 12 and Section 29.20 thereof. Selected projects that are 250 kW or greater, up to and including 5 MW will execute a Mid-Tier SFC with the Company which will not be subject to further regulatory review and approval. Selected SBO proposals, greater than 5 MW in size are required to file application pursuant to General Order No. 7 if the requirements for such filing are met. However, SBO proposals that are 250 kW or greater, up to and including 5 MW will also not be required to submit an additional application pursuant to General Order No. 7, but the Commission will hold the bidding utility to the terms of its bid, similar to an independent power producer.

#### **5.6 Facility In-Service**

In order to facilitate the timely commissioning of the projects selected through this RFP, the Company requires the following be included with the 60% design drawings: relay settings and protection coordination study, including fuse selection and ac/dc schematic trip scheme.

For the Company to test the Facility, coordination between the Company and Project is required. Drawings must be approved by the Company prior to testing. The entire Facility must be ready for testing to commence. Piecemeal testing will not be allowed. Communication infrastructure and equipment must be tested by the IPP and ready for operation prior to Company testing.

If approved drawings are not available, or if the Facility is otherwise not test ready as scheduled, the Project may lose its place in the queue, with the Company retaining the

flexibility to adjust scheduling as it sees fit. If tests are not completed within the allotted scheduled testing time, the Project will be moved to the end of the Company's testing queue. The IPP will be allowed to cure if successful testing is completed within the allotted scheduled time. No adjustments will be made to RDG PPA or Mid-Tier SFC milestones if tests are not completed within the original allotted time. Liquidated damages for missed milestones will be assessed pursuant to the RDG PPA or Mid-Tier SFC.



**DRAFT**  
**REQUEST FOR PROPOSALS**  
**FOR**  
**COMMUNITY-BASED RENEWABLE ENERGY TRANCHE 1**  
**ISLAND OF O‘AHU**

DECEMBER 1, 2020

Docket No. 2015-0389

*Appendix A – Definitions*



**Hawaiian  
Electric**

“Affiliate” means any person or entity that possesses an “affiliated interest” in a utility as defined by section 269-19.5, Hawaii Revised Statutes (“HRS”), including a utility’s parent holding company but excluding a utility’s subsidiary or parent which is also a regulated utility.

“Allowed Capacity” has the meaning set forth in the RDG PPA and Mid-Tier SFC.

“Best and Final Offer” or “BAFO” means the final offer from a Proposer, as further described in Section 4.6 and elsewhere in this RFP.

“CBRE NDA” means the Mutual Confidentiality and Non-Disclosure Agreement attached to this RFP as Appendix E.

“Code of Conduct” means the code of conduct approved by the PUC in Docket No. 03-0372 (Decision and Order No. 23614, August 28, 2007) with respect to a Self-Build Option. An updated code of conduct was submitted to the PUC in Docket No. 2015-0389 on July 9, 2020.

“Code of Conduct Procedures Manual” or “Procedures Manual” means the manual approved by the PUC, which was put in place to address and to safeguard against preferential treatment or preferential access to information in a Hawaiian Electric, Maui Electric, or Hawaii Electric Light RFP process. The Procedures Manual is attached as Appendix C to this RFP.

“Commercial Operations” has the meaning set forth in the RDG PPA and Mid-Tier SFC.

“Community Outreach Plan” is a community outreach and communication plan described in Section 4.3 and 4.4.2 of this RFP.

“Company” means Hawaiian Electric Company, Inc., a Hawai‘i corporation.

“Company-Owned Interconnection Facilities” has the meaning set forth in the RDG PPA and Mid-Tier SFC.

“Competitive Bidding Framework” or “Framework” means the Framework for Competitive Bidding contained in Decision and Order No. 23121 issued by the Public Utilities Commission on December 8, 2006, and any subsequent orders providing for modifications from those set forth in Order No. 23121 issued December 8, 2006.

“Consumer Advocate” means the Division of Consumer Advocacy of the Department of Commerce and Consumer Affairs of the State of Hawai‘i.

“Day” means a calendar day, unless the term “business day” is used, which means calendar day excluding weekends and federal and State of Hawai‘i holidays.

“Development Period Security” has the meaning set forth in Section 14.2 of the RDG PPA and the Mid-Tier SFC.

“Dispatchable” means the ability to turn on or turn off a generating resource at the request of the utility’s system operators, or the ability to increase or decrease the output of a generating resource from moment to moment in response to signals from a utility’s Automatic Generation Control

System, Energy Management System or similar control system, or at the request of the utility's system operators.

“Electronic Procurement Platform” means the third-party web-based sourcing platform that will be used for the intake of Proposals and associated electronic information, storage and handling of Proposer information, and communication.

“Eligibility Requirements” has the meaning set forth in Section 4.2 of this RFP.

“Eligible Proposals” means Proposals that meet both the Eligibility and Threshold Requirements.

“Energy Contract Manager” is the primary Company contact for this RFP.

“Evaluation Team” means agents of the Company who evaluate Proposals.

“Facility” has the meaning set forth in the RDG PPA and Mid-Tier SFC.

“Facilities Studies” means a study to develop the interconnection facilities cost and schedule estimate including the cost associated with the design and construction of the Company-owned interconnection facilities.

“Final Award Group” means the group of Proposers selected by the Company from the Priority List, with which the Company will begin contract negotiations, based on the results of the Company's detailed evaluation.

“Greenhouse Gas” or “GHG” are gases that contribute to the greenhouse gas effect and trap heat in the atmosphere.

“Guaranteed Commercial Operations Date” or “GCOD” means the date on which a Facility first achieves Commercial Operations.

“Hawaiian Electric” means Hawaiian Electric Company, Inc., a Hawai'i corporation.

“Hawaiian Electric Companies” or “Companies” means Hawaiian Electric Company, Inc. and its subsidiaries, Hawaii Electric Light Company, Inc. and Maui Electric Company, Limited.

“Hawaiian Electric System” or “System” means the electric system owned and operated by Hawaiian Electric on the island of O'ahu (including any non-utility owned facilities) consisting of power plants, transmission and distribution lines, and related equipment for the production and delivery of electric power to the public.

“HRS” means the Hawai'i Revised Statutes as of the date of this Request for Proposals.

“Imputed Debt” means adjustments to the debt amounts reported on financial statements prepared under generally accepted accounting principles (“GAAP”). Certain obligations do not meet the GAAP criteria of “debt” but have debt-like characteristics; therefore, credit rating agencies “impute debt and interest” in evaluating the financial ratios of a company.

“Independent Observer” has the meaning set forth in Section 1.4 of this RFP.

“Independent Power Producer” or “IPP” means an entity that owns or operates an electricity generating facility that is not included in the Company’s rate base.

“Interconnection Facilities” means the equipment and devices required to permit a Facility to operate in parallel with, and deliver electric energy to, the Company System (in accordance with applicable provisions of the Commission’s General Order No. 7, Company tariffs, operational practices, interconnection requirements studies, and planning criteria), such as, but not limited to, transmission and distribution lines, transformers, switches, and circuit breakers. Interconnection Facilities includes Company-Owned Interconnection Facilities and Seller-Owned Interconnection Facilities.

“Interconnection Requirements Study” or “IRS” means a study, performed in accordance with the terms of the IRS Letter Agreement, to assess, among other things, (1) the system requirements and equipment requirements to interconnect the Facility with the Company System, (2) the Performance Standards of the Facility, and (3) an estimate of interconnection costs and project schedule for interconnection of the Facility.

“kV” means kilovolt.

“Land RFI” refers to a Request for Information activity conducted by the Company to identify interested parties willing to make land available for utility-scale renewable energy projects and gather relevant property information.

“Levelized Benefit” or “LB” means a calculation (\$/MWh) used for comparison of Proposals based on information provided in the Proposal submission in this RFP.

“LMI Anchor Tenant” is as defined in Tariff Rule No. 29 in Appendix J.

“LMI Subscriber” means either a LMI Customer or LMI Anchor Tenant as defined in Tariff Rule No. 29 in Appendix J.

“Low- and Moderate-Income Customer” or “LMI Customer” is as defined in Tariff Rule No. 29 in Appendix J.

“Lump Sum Payment” has the meaning set forth in the RDG PPA or Mid-Tier SFC. It may also be referred to as a monthly Lump Sum Payment to reflect the portion of the payment made each month.

“Mediation” means the confidential mediation conducted in Honolulu, Hawai‘i, pursuant to and in accordance with the Mediation Rules, Procedures, and Protocols of Dispute Prevention Resolution, Inc. (or its successor) or, in its absence, the American Arbitration Association then in effect.

“Mid-Tier Standard Form Contract” or “Mid-Tier SFC” means the pre-approved standard form contract that will be used for projects 250 kW or greater in size, up to and including 5 MW, in the form of Appendix L or N of this RFP.

“MW” means megawatt.

“MWh” means megawatt hour.

“NEP” means Net Energy Potential.

“Non-Price Evaluation Team” means Employees and consultants of the Company who evaluate the Proposal non-price related criteria as set forth in Section 4.4 of this RFP. Non-Price Evaluation Team members will not include any Shared Resources and will be solely made up of Company RFP Team Members.

“O&M” means operation and maintenance.

“Operating Period Security” has the meaning set forth in Section 14.4 of the RDG PPA and Mid-Tier SFC.

“Paired Projects” means a Project proposed that incorporates both an energy generation component and an energy storage component as part of its Facility.

“Performance Standards” means the various performance standards for the operation of the Facility to the Company as set forth in Section 3 of Appendix B, as such standards may be revised from time to time pursuant to Article 23 of the RDG PPA or the Mid-Tier SFC, and as described in Chapter 2 of this RFP.

“Point of Interconnection” has the meaning set forth in the RDG PPA and Mid-Tier SFC.

“Power Purchase Agreement” or “PPA” means an agreement between an electric utility company and the developer of a renewable energy generation facility to sell the power generated by the facility to the electric utility company.

“Price Evaluation Team” means Employees and consultants of the Company who evaluate the Proposal price related criteria as set forth in Section 4.4 of this RFP. Price Evaluation Team members will not include any Shared Resources and will be solely made up of Company RFP Team Members.

“Price for Purchase of Electric Energy” is the amount that the Company will pay the Seller for electric energy delivered to the Company in accordance with the terms and conditions of the RDG PPA on a monthly basis as described in Attachment J. This payment will be calculated in terms of dollars per MWh.

“Priority List” means the group of Proposals selected by Hawaiian Electric as described in Section 4.5 of this RFP.

“Project” means a Facility proposed to Hawaiian Electric by a Proposer pursuant to this RFP.

“Proposal” means a proposal submitted to Hawaiian Electric by a Proposer pursuant to this RFP.

“Proposal Due Date” means the date stated in RFP Schedule - Row 6 for IPP and Affiliate Proposals of this RFP.

“Proposal Fee” means the non-refundable fee for each proposal submitted as set forth in Section 1.8 of this RFP.

“Proposer” means a person or entity that submits a Proposal to Hawaiian Electric pursuant to this RFP.

“Proposer’s Response Package” means the form in which the Proposal should be submitted, which is attached as Appendix B to this RFP.

“PUC” means the State of Hawai‘i Public Utilities Commission.

“RDG PPA” means the Model PV and/or Wind Renewable Dispatchable Generation Power Purchase Agreement that will be used for projects greater than 5 MW in size, attached as Appendix K and Appendix M respectively to this RFP.

“Renewable Portfolio Standards” or “RPS” means the Hawai‘i law that mandates that the Company and its subsidiaries generate or purchase certain amounts of their net electricity sales over time from qualified renewable resources. The RPS requirements in Hawai‘i are currently codified in HRS §§ 269-91 through 269-95.

“Request for Proposals” or “RFP” means a request for Proposals issued pursuant to a competitive bidding process authorized, reviewed, and approved by the PUC.

“RFP Schedule” means the schedule set forth in Table 1, Section 3.1 of this RFP.

“Self-Build Option” or “SBO” means a Proposal submitted by the Company that is responsive to the resource need identified in the RFP, as required by Section VI of the Framework.

“Self-Build Team” means agents of the Company who develop Self-Build Option proposals.

“Seller” means the entity that the Company is contracting with, as set forth in the RDG PPA and Mid-Tier SFC.

“Seller-Owned Interconnection Facilities” has the meaning set forth in the RDG PPA and Mid-Tier SFC.

“Site” means the parcel of real property on which the Facility, or any portion thereof, will be constructed and located, together with any Land Rights reasonably necessary for the construction, ownership, operation and maintenance of the Facility.

“Site Control” has the meaning set forth in Section 4.3 of this RFP.

“Threshold Requirements” has the meaning set forth in Section 4.3 of this RFP.

Any capitalized term not defined in this RFP has the meaning set forth in the RDG PPA and Mid-Tier SFC.

**DRAFT**  
**REQUEST FOR PROPOSALS**  
**FOR**  
**COMMUNITY-BASED RENEWABLE ENERGY TRANCHE 1**  
**ISLAND OF O‘AHU**

DECEMBER 1, 2020

Docket No. 2015-0389

*Appendix B – Proposer’s Response Package /  
Project Interconnection Data Request*



**Hawaiian  
Electric**

## 1.0 GENERAL INSTRUCTIONS TO PROPOSERS

The Company has elected to use the services of PowerAdvocate®, a third-party electronic platform provider. Sourcing Intelligence®, developed by PowerAdvocate®, is the Electronic Procurement Platform that the Company has licensed and will utilize for the RFP process. All Proposals and all relevant information must be submitted via the Electronic Procurement Platform, in the manner described in this RFP.

Proposers must adhere to the response structure and file naming conventions identified in this Appendix for the Proposer's response package. Information submitted in the wrong location/section or submitted through communication means not specifically identified by the Company will not be considered by the Company.

Proposers must provide a response for every item. If input/submission items in the RFP are not applicable to a specific Proposer or Proposal variation, Proposers must clearly mark such items as "N/A" (Not Applicable) and provide a brief explanation.

Proposers must clearly identify all confidential information in their Proposals, as described in more detail in Section 3.12 Confidentiality of the RFP.

All information (including attachments) must be provided in English. All financial information must be provided in U.S. Dollars and using U.S. credit ratings.

It is the Proposer's sole responsibility to notify the Company of any conflicting requirements, ambiguities, omission of information, or the need for clarification prior to submitting a Proposal.

The RFP will be conducted as a "Sealed Bid" event within Sourcing Intelligence, meaning the Company will not be able to see or access any of the Proposer's submitted information until after the event closes.

### 1.1 ELECTRONIC PROCUREMENT PLATFORM

To access the RFP event, the Proposer must register as a "Supplier"<sup>1</sup> on Sourcing Intelligence (Electronic Procurement Platform). One Proposal may be submitted with each Supplier registration. Minor variations, as defined in Section 1.8.2 and 1.8.3 of this RFP may be submitted along with the Proposal under the same registration.

If a Proposer is already registered on Sourcing Intelligence, the Proposer may use their current login information to submit their Proposal. Two variations of a Proposal, one variation of which is the base variation of the Proposal, may be submitted together as a Proposal by following the instructions outlined in this Appendix (see Section 4 below). If the Proposer chooses to submit more than one Proposal, the Proposer must register as a new "Supplier" on Sourcing Intelligence for each additional Proposal.

Each registration will require a unique username, unique Email address, and unique Company name. Proposers that require multiple registrations to submit multiple Proposals should use the Company name field to represent

---

<sup>1</sup> The language in Appendix B sometimes refers to "Energy Contract Managers" as "Bid Event Coordinator" and to "Proposers" as "Suppliers" (Bid Event Coordinator and Supplier are terms used by PowerAdvocate).



the Company name and Proposal number (ex: CompanyNameP1). Proposers may use shorthand or clear abbreviations. The unique Email address used to create the PowerAdvocate account does not necessarily have to match the Email address specified in Section 2.2.1 below. For example, if the Proposer is submitting multiple Proposals, all of the Proposer's Proposals could specify the same primary point of contact Email address if that is what the Proposer requests contact through for all their proposals.

Proposers can register for an account on Sourcing Intelligence by clicking on the "Registration" button (located in the top right corner of the webpage) on the PowerAdvocate website at the following address:

[www.poweradvocate.com](http://www.poweradvocate.com)

The Proposer's use of the Electronic Procurement Platform is governed by PowerAdvocate's Terms of Use. By registering as a "Supplier" on the Electronic Procurement Platform, the Proposer acknowledges that the Proposer has read these Terms of Use and accepts and agrees that, each time the Proposer uses the Electronic Procurement Platform, the Proposer will be bound by the Terms of Use then accessible through the link(s) on the PowerAdvocate login page.

Once a Proposer has successfully registered as a "Supplier" with PowerAdvocate, the Proposer shall request access to the subject RFP event from the Company Contact via Email through the RFP Email Address set forth in Section 1.6 of the RFP. The Email request must list the Company Name field and username under which the Proposer has registered with PowerAdvocate. If the Proposer plans to submit multiple Proposals and has registered multiple accounts in accordance with the instructions above, the Email request must contain the Company Name field and username for each account that will be used to submit the Proposals. After being added to the event, the Proposer will see the bid event on their dashboard upon logging into Sourcing Intelligence. Once the RFP event opens, the Proposer may begin submitting their Proposal(s).

After registering and prior to the opening of the RFP, Proposers are encouraged to familiarize themselves with the Electronic Procurement Platform, including tabs, the dashboard, PowerAdvocate Users Guide (RFP Appendix D), etc. Proposers should note that they will not be able to access any bid documents until the event officially opens.

Proposers may contact PowerAdvocate Support for help with registration or modification of registration if desired. Support is available from 8 AM to 8 PM Eastern Time (2 AM to 2 PM Hawai'i Standard Time when daylight savings is in effect) Monday to Friday, except for Holidays posted on the PowerAdvocate website, both by phone (857-453-5800) and by Email ([support@poweradvocate.com](mailto:support@poweradvocate.com)).

Contact information for PowerAdvocate Support can also be found on the bottom border of the PowerAdvocate website: [www.poweradvocate.com](http://www.poweradvocate.com)

Once the RFP event is opened, registered Proposers will have online access to general notices and RFP-related documents via the Electronic Procurement Platform. Proposers should also monitor the RFP Website throughout the RFP event.

## **1.2 PROPOSAL SUBMISSION PROCEDURES**

An Email notification will be sent to all registered Proposers when the event has been opened to receive Proposals.

After logging onto the Electronic Procurement Platform, the RFP will be visible on the Proposer's dashboard with several tabs, including the following:

- **"1. Download Documents:"** Documents stored under this tab are provided for the Proposer's use and information. All documents can be downloaded and/or printed, as required.
- **"2. Upload Documents:"** Proposal submission documents requested in Appendix B must be uploaded using this tab.
- Note that "3. Commercial Data:", "4. Technical Data:", and "5. Pricing Data:" tabs are NOT USED for this event.

Step-by-step instructions for submitting a complete Proposal are provided below:

1. Proposers must upload their Proposal files, including all required forms and files, to submit a complete Proposal. All files must be uploaded before the respective Proposal Due Date (RFP Section 3.1 Item 6 or Item 7).
2. Submit (upload) one consolidated PDF representing your Proposal via the "2. Upload Documents" tab. That Proposal PDF must abide by the format specified in this Appendix B. A MSWord.docx template that outlines the format of this document is available under the "1. Download Documents" tab for the Proposer's use. **Response information must be provided in the order, format, and manner specified in this Appendix B and must clearly identify and reference the Appendix B section number that the information relates to.**
  - a. Proposers shall use a filename denoting: CompanyName\_Proposal#.pdf.  
(example: AceEnergy\_P1.pdf)
3. Proposal information that cannot be easily consolidated into the PDF file described in Step 2 (such as large-scale drawing files) or files that must remain in native file format (such as computer models and spreadsheets) shall be **uploaded separately but must be referenced from within the main Proposal PDF file** (e.g., "See AceEnergyP1V2\_2.5\_SiteControlMap.kmz"). Such additional files must follow the naming convention below:
  - a. File names must include, in order, Company Name, Proposal number (if more than one Proposal being submitted per Proposer), Variation (if any variations are being submitted), Appendix B section number, and a file descriptor, as shown in the example file name below:  
AceEnergyP1V2\_2.5\_SiteControlMap.kmz  
Proposers may use abbreviations if they are clear and easy to follow.
4. Upload files using the **"2. Upload Documents"** tab on the Electronic Procurement Platform.
  - a. For all documents identify the "Document Type" as "Technical Information." (Do not identify any documents as "Commercial and Administrative" or "Pricing.")
  - b. "Reference ID" may be left blank.
  - c. Select "Choose File..." Navigate to and choose the corresponding file from your computer. Select "Open" and then "Submit Document."

There is no limit to the number or size of files that can be uploaded. Multiple files may be grouped into a .zip archive for upload. (Any zipped files must still adhere to the naming directions in #3 above.) When

successfully uploaded, documents will appear under the "Bid Submissions" section on the bottom of the tab's page, organized within the "Technical Information" Document Type. Repeat steps a, b, and c, as required for each file upload.

If a file with the same name is uploaded twice, the Platform will automatically append a unique numerical extension to the Document Name. To delete a file that has been previously uploaded, click on the "X" button in the "Actions" column for the file to be deleted. Do not upload any files prior to the issuance of the Final RFP.

5. The Company will not be responsible for technical problems that interfere with the upload or download of Proposal information. Support is available to answer technical questions about PowerAdvocate's Sourcing Intelligence from 8 AM to 8 PM Eastern Time (2 AM to 2 PM Hawai'i Standard Time when daylight savings is in effect) Monday to Friday, except for Holidays posted on the PowerAdvocate website, both by phone (857-453-5800) and by Email (support@poweradvocate.com).
6. Proposers are strongly encouraged to start early and avoid waiting until the last minute to submit the required information. Proposers are allowed to add, modify, and/or delete documents that have been previously submitted any time prior to the event close deadline. For clarity, it is the Proposer's responsibility to ensure a complete Proposal is uploaded into PowerAdvocate before the Proposal Due Date.
7. Any questions or concerns regarding the RFP, may be submitted to the Company Contact via the RFP Email address provided in Section 1.6 of the RFP. Per RFP Section 1.4.2, the Independent Observer will monitor messages within the bid event. Proposers are responsible for following instructions and uploading documents in their appropriate locations. Documents uploaded in the wrong tab will not be considered by the Company.

### 1.3 PROPOSAL COMPLETION AND CONFIRMATION PROCEDURES

To confirm the submission of all proposal files, in the "Status" tab on the Electronic Procurement Platform, confirm that the "Total Uploaded Files" is the number of expected files to be included in the submission by checking it against your list of submitted files. Example "Status" tab view:

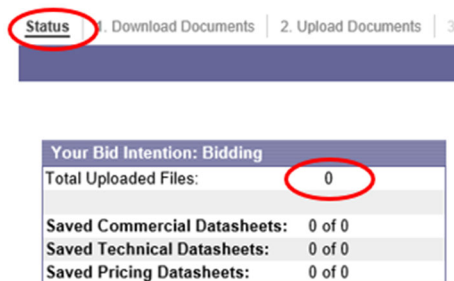

As stated above in Section 1.2, nothing should be uploaded to the Commercial, Technical or Pricing Datasheet tabs. Documents uploaded there will not be included in your Proposal submission.

1.3.1 **Proposal Fee Delivery Information.** Provide the Proposal Fee submission information for this Proposal. Include:

- The Date the Proposal Fee was sent.
- The delivery service used and the tracking number for the parcel.
- The U.S.-chartered bank name that issued the cashier’s check and the check number.

## 2.0 PROPOSAL (BASE VARIATION) SUMMARY TABLE

Base variation Proposal Summary. If proposal variations are submitted, any changes to the summary information for such variations must be specifically identified in a similar table placed in Sections 4.2, 4.3, 4.4, etc. of this Appendix, as applicable.

To be filled out in its entirety by IPP or Affiliate Proposers:

1	<b>Proposer Name (Company Name)</b>	
2	<b>Parent Company/Owner/Sponsor/Business Affiliation/etc.</b>	
3	<b>Project Name</b>	
4	<b>Net AC Capacity of the Facility (MW)</b>	
5	<b>Proposed Facility Location, Street Address if available, or what City/Area on the island is it near</b>	
6	<b>TMK(s) of Facility Location (use 9-digit TMK format)<sup>2</sup></b>	
7	<b>Point of Interconnection’s Circuit Name</b>	
8	<b>Coordinates for Point of Interconnection (use decimal degrees)<sup>3</sup></b>	
9	<b>Project Generation Technology</b>	
10	<b>Net Energy Potential (NEP) Projection for the Facility (MWh)</b>	
11	<b>Lump Sum Payment (\$/Year)</b>	
12	<b>Price for Purchase of Electric/Renewable Energy (\$/MWh) (optional and only for wind projects)</b>	
13	<b>Does Project include an Energy Storage Component? (Yes/No)</b>	
If the Project includes an Energy Storage Component:		
14	<b>Project Energy Storage Technology</b>	
15	<b>Energy Storage Capability for the Facility (MW and MWh)</b>	
16	<b>Is the Project capable of being 100% charged from the grid after the 5 year ITC recapture period? (Yes/No)</b>	
17	<b>Is the Project grid-forming and black start capable? (Yes/No)</b>	
18	<b>Proposal Guaranteed Commercial Operations Date (MM/DD/YYYY)</b>	
19	<b>The Proposer hereby certifies that the Project meets all performance attributes identified in Section 2.1 of the RFP? (Yes/No)</b>	

<sup>2</sup> 9-digit Tax Map Key format: Island Number (1 digit); Zone Number (1 digit); Section Number (1 digit); Plat Number (3 digits, add leading zeros if less than 3 digits); Parcel Number (3 digits, add leading zeros if less than 3 digits).

<sup>3</sup> Decimal degrees (YY.YYYYYY, -XXX.XXXXXX) latitude and longitude coordinates of the Point of Interconnection for the project. If there is more than one interconnection point, specify each.

20	<b>The Proposer hereby certifies that the Proposal (including its pricing elements) is not contingent upon changes to existing County, State or Federal laws or regulations. (Yes/No)</b>	
21	<b>The Proposer hereby agrees to provide Development Period Security and Operating Period Security as set forth in the applicable Model RDG PPA or Model Mid-Tier SFC. (Yes/No)</b>	
22	<b>The Proposer hereby certifies under penalties of perjury that this Proposal has been made in good faith and without collusion or fraud with any other person. As used in this certification, the word “person” shall mean any natural person, business partnership, corporation, union, committee, club, or organization, entity, or group of individuals. (Yes/No)</b>	
23	<b>The Proposer hereby certifies that the Proposer, its parent company, or any affiliate of the Proposer has not either defaulted on a current contract with the Company, had a contract terminated by the Company, or has any pending litigation with the Company (Yes/No)</b>	
24	<b>The Proposer hereby certifies that the Project is dedicated to LMI Subscribers with a minimum 60% dedicated to LMI Customers as described in Section 1.2.3 of the RFP? (Yes/No)</b>	

To be filled out in its entirety by Self-Build Proposers:

1	<b>Proposer Name (Company Name)</b>	
2	<b>Parent Company/Owner/Sponsor/Business Affiliation/etc.</b>	
3	<b>Project Name</b>	
4	<b>Net AC Capacity of the Facility (MW)</b>	
5	<b>Proposed Facility Location, Street Address if available, or what City/Area on the island is it near</b>	
6	<b>TMK(s) of Facility Location (use 9-digit TMK format)<sup>4</sup></b>	
7	<b>Point of Interconnection’s Circuit Name</b>	
8	<b>Coordinates for Point of Interconnection (use decimal degrees)<sup>5</sup></b>	
9	<b>Project Generation Technology</b>	
10	<b>Net Energy Potential (NEP) Projection for the Facility (MWh)</b>	
11	<b>Does Project include an Energy Storage Component? (Yes/No)</b>	
If the Project includes an Energy Storage Component:		
12	<b>Project Energy Storage Technology</b>	
13	<b>Energy Storage Capability for the Facility (MW and MWh)</b>	
14	<b>Is the Project capable of being 100% charged from the grid after the 5 year ITC recapture period? (Yes/No)</b>	
15	<b>Is the Project grid-forming and black start capable? (Yes/No)</b>	
16	<b>Proposal Guaranteed Commercial Operations Date (MM/DD/YYYY)</b>	
17	<b>The Proposer hereby certifies that the Project meets all performance attributes identified in Section 2.1 of the RFP? (Yes/No)</b>	
18	<b>The Proposer hereby certifies that the Proposal (including its pricing elements) is not contingent upon changes to existing County, State or Federal laws or regulations. (Yes/No)</b>	
19	<b>The Proposer hereby agrees to provide Development Period Security and Operating Period Security as set forth in the applicable Model RDG PPA or Model Mid-Tier SFC. (Yes/No)</b>	

<sup>4</sup> 9-digit Tax Map Key format: Island Number (1 digit); Zone Number (1 digit); Section Number (1 digit); Plat Number (3 digits, add leading zeros if less than 3 digits); Parcel Number (3 digits, add leading zeros if less than 3 digits).

<sup>5</sup> Decimal degrees (YY.YYYYYY, -XXX.XXXXXX) latitude and longitude coordinates of the Point of Interconnection for the project. If there is more than one interconnection point, specify each.

20	<b>The Proposer hereby certifies under penalties of perjury that this Proposal has been made in good faith and without collusion or fraud with any other person. As used in this certification, the word “person” shall mean any natural person, business partnership, corporation, union, committee, club, or organization, entity, or group of individuals.</b> (Yes/No)	
21	<b>The Proposer hereby certifies that the Project is dedicated to LMI Subscribers with a minimum 60% dedicated to LMI Customers as described in Section 1.2.3 of the RFP?</b> (Yes/No)	
22	<b>Year (YYYY)</b>	<b>Project Capital Cost (\$)</b>
23	<b>Year (YYYY)</b>	<b>O&amp;M Cost (\$)</b>
24	<b>Year (YYYY)</b>	<b>Annual Revenue Requirement (\$)</b>

## 2.1 REQUIRED FORMS ACCOMPANYING PROPOSAL PDF

The following forms must accompany each proposal, must be attached to the Proposal PDF, and uploaded via the “2. Upload Documents” tab:

- Document signed by an officer or other Proposer representative **authorizing the submission** of the Proposal
- Fully executed **CBRE Mutual Confidentiality and Non-Disclosure Agreement** (Appendix E to the RFP, may be downloaded from the “1. Download Documents” tab in the Electronic Procurement Platform)
- **Certificate of Vendor Compliance** for the Proposer
  - **Certificate of Good Standing** for the Proposer and **Federal and State tax clearance certificates** for the Proposer may be provided in lieu of the Certificate of Vendor Compliance
- **Certification of Counsel for Proposer**, if applicable. (See Appendix B Attachment 1.)
- Completed applicable **Project Interconnection Data Request worksheet** for the proposed technology and **project diagram(s)**. **Models for equipment and controls, list(s)** identifying components and **respective files** (for inverters and power plant controller), and **complete documentation with**

**instructions** as specified in the Data Request worksheet shall be submitted within the respective timeframes specified in Section 5.1 of the RFP.<sup>6</sup> (See Section 2.11.1 below)

- [For Self-Build Only] **Self-Build Option Team Certification Form**. See Appendix G Attachment 1.
- [For Self-Build Only] **Revenue Requirements Worksheets** that support the annual revenue requirements estimates shall be submitted. A starter revenue requirements template file can be requested by the Self-Build Team via email to the RFP Email Address once the RFP event opens. The revenue requirements worksheets submitted will be modified to reflect the details of the Project's Proposal. All assumptions used will be reflected in an assumptions input tab.

## 2.2 PROPOSAL SUMMARY/CONTACT INFORMATION

2.2.1 Provide a **primary point of contact** for the Proposal being submitted:

- Name
- Title
- Mailing Address
- Phone Number
- Email Address – this will be the official communication address used during the RFP process

2.2.2 **Executive Summary of Proposal.** The executive summary must include an approach and description of the important elements of the Proposal, including a description if a minor variation to the base variation is being submitted. Refer to Section 1.8.2 and 1.8.3 of the RFP for an explanation of minor variations that are allowed. If a minor variation to the base variation is proposed, a **table summarizing the differences of the minor variation in Section 4 shall be included.**

2.2.3 **Pricing information.** Pricing information must be filled out in the Section 2.0 Proposal Summary Table above. If a minor variation to the base variation is proposed, the minor variation's pricing summary must be identified in a similar pricing table in Sections 4.2.0 below. Proposers must provide pricing information only in those table sections – do not embed pricing information in any other portion of the Proposal PDF.

2.2.4 Provide a **high-level overview of the proposed Facility**, including at a minimum the following information:

- Facility Generation Size (MW<sub>AC</sub> and MW<sub>DC</sub>)
- Net Maximum Output Capacity of the Facility at the Point(s) of Interconnection (MW<sub>AC</sub>)
- Identified Available Hosting Capacity of the Distribution-level (25 kV or less) or Sub-Transmission level (46 kV) Circuit Facility Interconnecting to (MW<sub>AC</sub>), if available. If a Hosting Capacity value is provided, please describe the source of the value (i.e. LVM, Company response to Proposer's inquiry, etc.).
- Technology Type
- Number of Generators

---

<sup>6</sup> If the Models, lists, respective files and complete documentation are not submitted with the Proposal upload, they shall be submitted via PowerAdvocate's Messaging as attachments within the respective timeframes specified in Section 5.1 of the RFP.

- Rated Output of each Generator
- Generator Facility Design Characteristics

For projects that include a storage component:

- Technology Type (i.e. lithium ion battery)
- Maximum Rated Output, as defined in the applicable contract (MW)
- Discharge Duration at Maximum Rated Output (hours)
- Storage Energy Capacity (MWh) available at the point of interconnection (i.e. BESS Contract Capacity as defined in the applicable contract)
- Operational Limitations, such as but not limited to: grid charging limits (with respect to ITC), energy throughput limits (daily, monthly, annually), State of Charge restrictions (min/max SOC while at rest (not charging/discharging)), etc. Proposed Operational Limits cannot be in conflict with the energy discharge requirement in Sections 1.2.12 and 1.2.13 of the RFP. If such a conflict is identified, the Proposal may be disqualified.
- Round Trip Efficiency (“RTE”). Specify a single value (percentage) that the Facility is required to maintain throughout the term of the applicable contract. The RTE must consider and reflect:
  - the technical requirements of the Facility (as further set forth in the applicable contract);
  - that the measurement location of charging and discharged energy is at the point of interconnection;
  - electrical losses associated with the point of interconnection measurement location;
  - any auxiliary and station loads that need to be served by BESS energy during charge and discharge that may not be done at Maximum Rated Output or over a fixed duration; and
  - that the data used to validate the RTE will be captured during a full charge cycle (0%-100% SOC) directly followed by a full discharge cycle (100%-0% SOC).
- Describe any augmentation plans for the storage component to maintain the functionality and characteristics of the storage during the term of the applicable contract. Include any expected interval of augmentation (months/years).
- Estimated useful life of the storage component (including augmentation if used) (years)

2.2.5 If the Project requires a RDG PPA as specified in RFP Section 3.8, **state whether the Proposer accepts the contract terms** identified in the model RDG PPA in its entirety or if modifications to the model agreements are proposed. Specify the name of the Microsoft Word red-line file that identifies the proposed modifications to the model language that the Proposer is agreeable to.

## 2.3 FINANCIAL

Provide the following financial information identified below. As specified in the General Instructions in Section 1.0 above, all information (including attachments) must be provided in English, be provided in U.S. Dollars and use U. S. credit ratings.

2.3.1 Identification of Equity Participants

2.3.1.1 Who are the **equity participants** in the Project (or the equity partners’ other partners)?

2.3.1.2 Provide an **organizational structure** for the Proposer including any general and limited partners and providers of capital that identifies:

- Associated responsibilities from a financial and legal perspective



- Percentage interest of each party

### 2.3.2 Project Financing

2.3.2.1 **How will the Project be financed** (including construction and term financing)? Address at a minimum:

- The Project's projected financial structure
- Expected source of debt and equity financing

2.3.2.2 [For IPP and Affiliate Proposals] Identify all **estimated development and capital costs** for, at a minimum:

- Equipment
  - Identify the manufacturer and model number for all major equipment
- Construction
- Engineering
- Seller-Owned Interconnection Facilities
- Land
- Annual O&M
- (For Projects that include a storage component) Specify a percentage of the total project cost that is estimated to be attributed to the storage functionality of the Facility. As the storage functionality is treated as a lease, the Company will use the percentage for its preliminary calculation of the lease liability only. This percentage requested for the Company's accounting purposes does not affect nor alter the liquidated damage provisions of the PPA, as those provisions reflect the benefit the Company seeks from the Project's storage functionality.

[For Self-Build Only] Identify all **estimated development and capital costs** for, at a minimum:

- Facility (including any generation and storage components)
- Outside Services
- Interconnection
- Overhead Costs
- Allowance for Funds Used During Construction
- Annual O&M
- Specify the percentage of the total cost associated with the storage component of the Facility
- (For Projects that include a storage component) Specify a percentage of the total project cost that is estimated to be attributed to the storage functionality of the Facility. As the storage functionality is treated as a lease, the Company will use the percentage for its preliminary calculation of the lease liability only. This percentage requested for the Company's accounting purposes does not affect nor alter the liquidated damage provisions of the PPA, as those provisions reflect the benefit the Company seeks from the Project's storage functionality.

2.3.2.3 Discuss and/or provide **supporting information on any project financing guarantees**.

2.3.2.4 Describe any **written commitments obtained from the equity participants**.

2.3.2.5 Describe any **conditions precedent to project financing**, and the Proposer's plan to address them, other than execution of the Power Purchase Agreement or any other applicable project agreements and State of Hawai'i Public Utilities Commission approval of the Power Purchase Agreement and other agreements.

2.3.2.6 Provide any **additional evidence to demonstrate that the Project is financeable**.

2.3.3 Project Financing Experience of the Proposer

Describe **the project financing experience of the Proposer** in securing financing for projects of a similar size (i.e., no less than two-thirds the size) and technology as the one being proposed including the following information for any referenced projects:

- Project Name
- Project Technology
- Project Size
- Location
- Date of Construction and Permanent Financing
- Commercial Operations Date
- Proposer's Role in Financing of the Project
- Off-taker
- Term of the Interconnection Agreement
- Financing Structure
- Major Pricing Terms
- Name(s) of Finance Team Member(s); Time (i.e., years, months) worked on the project and Role/Responsibilities

2.3.4 Evidence of the Proposer's Financial Strength

2.3.4.1 Provide **copies of the Proposer's audited financial statements** (balance sheet, income statement, and statement of cash flows):

- Legal Entity
  - Three (3) most recent fiscal years
  - Quarterly report for the most recent quarter ended
- Parent Company
  - Three (3) most recent fiscal years
  - Quarterly report for the most recent quarter ended

2.3.4.2 Provide the **current credit ratings** for the Proposer (or Parent Company, if not available for Proposer), affiliates, partners, and credit support provider:

- Standard & Poor's
- Moody's
- Fitch

2.3.4.3 Describe any **current credit issues** regarding the Proposer or affiliate entities raised by rating agencies, banks, or accounting firms.

2.3.4.4 Provide any **additional evidence that the Proposer has the financial resources and financial strength** to complete and operate the Project as proposed.

2.3.5 Provide **evidence** that the Proposer can provide **the required securities**.

2.3.5.1 Describe the Proposer's **ability (and/or the ability of its credit support provider) and proposed plans to provide the required securities** including:

- Irrevocable standby letter of credit
- Sources of security
- Description of its credit support provider

2.3.6 Disclosure of Litigation and Disputes

Disclose any **litigation, disputes, and the status of any lawsuits or dispute resolution** related to projects owned or managed by the Proposer or any of its affiliates

## 2.4 CONTRACT EXCEPTIONS AND FINANCIAL COMPLIANCE

2.4.1 If Proposers elect to propose modifications to the Model RDG PPA, **provide a Microsoft Word red-line version of the Model RDG PPA** identifying specific proposed modifications to the model language that the Proposer is agreeable to and a detailed explanation and supporting rationale for each modification. General comments, drafting notes and footnotes such as “parties to discuss” are unacceptable and will be considered non-responsive.

Proposers that do not upload redlines of the applicable RDG PPA with their Proposal submission will be deemed to have accepted the Model RDG PPA in its entirety. If no modifications are proposed, please state in this section “no modifications to the Model RDG PPA”.

As set forth in RFP Section 3.8.5.1, proposed modifications to the RDG PPA will be subject to negotiation between the Company and the Final Award Group and should not be assumed to have been accepted either as a result of being selected to the Final Award Group or based on any previously executed PPA.

The Mid-Tier SFC for projects 250 kW or greater, up to and including 5 MW will be preapproved by the Commission and as a result, modifications may not be proposed to it.

2.4.2 State to the best of the Proposer's knowledge: Will the Project result in **consolidation** of the Developer entity's finances onto the Company's financial statements under FASB 810. **Provide supporting information** to allow the Company to verify such conclusion.

## 2.5 SITE CONTROL

2.5.1 The Proposal must demonstrate that the Proposer has Site Control for all real property required for the successful implementation of a specific Proposal at a Site not controlled by the Company, including any Interconnection Facilities for which the Proposer is responsible. In addition, developmental requirements and restrictions such as zoning of the Site and the status of easements must be identified. **Proposers must provide documentation set forth in RFP Section 4.3 to prove Site Control.**

2.5.2 Provide a **map of the Project site** that clearly identifies:

- Location of the parcel on which the site is located
- Tax map key number (9-digit format: Island Number (1 digit), Zone Number (1 digit), Section Number (1 digit), Plat Number (3 digits, add leading zeros if less than 3 digits), Parcel Number (3 digits, add leading zeros if less than 3 digits)
- Site boundaries (if the site does not cover the entire parcel)
- Total acreage of the site
- Point(s) of Interconnection
- Relationship of the site to other local infrastructure

2.5.3 Provide a **site layout plan** which illustrates:

- Proposed location of all equipment
- Proposed location of all facilities on the site, including any proposed line extensions

2.5.4 Describe the **interconnection route** and include:

- Site sketches of how the facility will be interconnected to the Company's System (above-ground and/or underground)
- Identify the approximate latitude and longitude of the proposed Point of Interconnection, in decimal degrees format, to six (6) decimal places.
- Description of the rationale for the interconnection route

2.5.5 Identify **any rights-of-way or easements** that are required for access to the site or for interconnection route:

- Describe the status of rights-of-way or easement acquisition
- Describe the plan for securing the necessary rights-of-way or easement, including the proposed timeline

2.5.6 Provide a **description of any critical infrastructure or community resilience hubs** in proximate location to the proposed Project site that could benefit from an islanding capability of the proposed Project and could enhance resilience in the community.

2.5.7 Indicate whether the Proposal is intended to partially or fully satisfy a Company identified Non-Wire Alternative as stated in Appendix O or the Company's Locational Value Map, and which locational need it intends to satisfy.

## 2.6 ENVIRONMENTAL COMPLIANCE AND PERMITTING PLAN

Scoring of proposals for the non-price evaluation criteria of this section will be based on the completeness and thoroughness of responses to each of the criteria listed below. The Company recommends that each Proposal incorporate the list below as an outline together with complete and thorough responses to each item in the list. Proposals that closely follow this recommendation will typically be awarded higher scores than proposals that do not.

2.6.1 Describe your **overall land use and environmental permits and approvals strategy** and approach to obtaining successful, positive results from the agencies and authorities having jurisdiction, including:

- Explanation of the conceptual plans for siting
- Studies/assessments
- Permits and approvals
- Gantt format schedule which identifies the sequencing of permit application and approval activities and critical path. (Schedule must be in MM/DD/YY format.)

2.6.2 Discuss the **city zoning and state land use classification**:

- Identify present and required zoning and the ability to site the proposed Project within those zoning allowances.
- Identify present and required land use classifications and the ability to site the proposed Project within those classifications.
- Provide evidence of proper zoning and land use classifications for selected site and interconnection route.
- If changes in the above are required for the proposed Project, provide a plan and timeline to secure the necessary approvals.

2.6.3 Identify all required discretionary and non-discretionary **land use, environmental and construction permits, and approvals** required for development, financing, construction, and operation of the proposed Project, including but not limited to zoning changes, Environmental Assessments, and/or Environmental Impacts Statements.

Provide a **listing of such permits and approvals** indicating:

- Permit Name
- Federal, State, or Local agencies and authorities having jurisdiction over the issuance
- Status of approval and anticipated timeline for seeking and receiving the required permit and/or license
- Explanation of your basis for the assumed timeline
- Explain any situation where a permit or license for one aspect of the Project may influence the timing or permit of another aspect (e.g. a case where one permit is contingent upon completion of another permit or license), if applicable.
- Explain your plans to secure all permits and approvals required for the Project.

2.6.4 Provide a **preliminary environmental assessment of the site** (including any pre-existing environmental conditions) and potential short- and long-term **impacts** associated with, or resulting from, the proposed Project – including direct, indirect, and cumulative impacts associated with development, construction, operation, and maintenance of the proposed Project in every area identified below. Discuss if alternatives have been or will be considered. The assessment shall also include Proposer’s short- and long-term plans to mitigate such impacts and explanation of the mitigation strategies for, but not limited to, each of the major environmental areas as presented below:

- Natural Environment
  - Air quality
  - Biology (Natural habitats and ecosystems, flora/fauna/vegetation, and animals, especially if threatened or endangered)
  - Climate
  - Soils
  - Topography and geology
- Land Regulation
  - Land Uses, including any land use restrictions and/or pre-existing environmental conditions/contamination

- Flood and tsunami hazards
- Noise
- Roadways and Traffic
- Utilities
- Socio-Economic Characteristics
- Aesthetic/Visual Resources
- Solid Waste
- Hazardous Materials
- Water Quality
- Public Safety Services (Police, Fire, Emergency Medical Services)
- Recreation
- Potential Cumulative and Secondary Impacts

2.6.5 Provide a **decommissioning plan**, including:

- Developing and implementing program for recycling to the fullest extent possible, or otherwise properly disposing of installed infrastructure, if any, and
- Demonstrating how restoration of the Site to its original ecological condition is guaranteed in the event of default by the Proposer in the applicable Site Control documentation.

## 2.7 CULTURAL RESOURCE IMPACTS

2.7.1 Provide a **plan to address the below requirements** as they pertain to the Project Site and interconnection route including the status of any consultant/s with expertise in this field that have been identified and/or contracted with, and documentation of any assessments or work that has been planned or performed to date. Identify any cultural, historical or natural resources in the area in question. For any impacts identified to the categories listed below, provide a mitigation strategy and the expected impact on the Project schedule. Detail the potential impacts of the Proposal on cultural resources in the short- and long-term and the Proposer's plan to mitigate such impacts. Proposers must provide as much information as possible to allow the Company to understand the considerations.

- Archaeological Resources
- Cultural Practices and Resources

## 2.8 COMMUNITY OUTREACH

Gaining community support is an important part of a Project's viability and success. An effective Community Outreach Plan will call for early meaningful communications with stakeholders and will reflect a deep understanding and respect for the community's desire for information. The public meeting and comment solicitation process described in Section 5.3 of the RFP is intended to support that premise and the Commission's desire to increase bid transparency within the RFP process. When developers neglect to demonstrate transparency and a willingness to engage in early and frequent communication with Hawaii's communities, costly and timely challenges to their projects have resulted. In some instances, projects have failed. Incorporating transparency during the competitive bidding phase may seem unconventional, but it has become an essential community expectation. Developers must share information and work with communities to address concerns through careful listening, thoughtful responsiveness, and a commitment to respect the environmental and cultural values of Hawai'i.

2.8.1 Provide a **detailed Community Outreach Plan** to work with and inform neighboring communities and stakeholders and to provide them timely information during all phases of the Project. The plan shall address, but not be limited to, the following items:

- Project description
- Community scoping
- Project benefits
- Government approvals
- Development process
  - Identification of communities and other stakeholders that may be affected by the proposed Project:
    - How will they be affected?
    - What mitigation strategies will the Proposer implement?
- Comprehensive communication strategy with affected communities and the general public regarding the proposed Project:
  - Describe frequency of communication
  - Provide source of information
  - Identify communication outlets
  - Describe opportunities, if any for affected communities and general public to provide the developer with feedback and comments on the proposed Project

Proposers are reminded of RFP Section 3.4.2 including the provision of Proposals must provide all referenced material if it is to be considered during the Proposal evaluation.

2.8.2 Provide any **documentation of local community support or opposition** including any letters from local organizations, newspaper articles, or communications from local officials.

2.8.3 Provide a **description of community outreach efforts** already taken or currently underway, including the names of organizations and stakeholders contacted about the proposed Project.

2.8.4 Describe any anticipated or negotiated investment in the community and other **community benefits** that the Proposer proposes to provide in connection with the Project, along with an estimated value of the community benefits in dollars (including the cost to Proposers providing the benefits and supporting details on how those costs and benefits were derived).

2.8.5 All Proposers selected to the Final Award Group must display the below table of information on their website as described in Section 5.3 of the RFP to provide communities Project information that is of interest to them in a standard format. All information in this table must be included in all community presentations in addition to the Proposer’s project website.

**PROJECT SUMMARY AND COMMUNITY OUTREACH PLAN**

*	Proposer Name (Company name)	
*	Parent Company/Owner/Sponsor/Business Affiliation/etc.	
*	Project Name	
*	Net AC Capacity of the Facility (MW) (must match Proposal information)	

*	Proposed Facility Location, Street Address if available, or what City/Area on the island it is near	
*	TMK(s) of Facility Location (must match Proposal information)	
*	Point of Interconnection's Circuit (must match Proposal information)	
*	Project Description (in 200 words or less)	<i>(A description that includes information about the project that will enable the community to understand the impact that the Project might have on the community.)</i>
*	Project site map	<i>(provide a map similar to what was provided in Section 2.5.2)</i>
*	Site layout plan	<i>(provide a layout similar to what was provided in Section 2.5.3)</i>
*	Interconnection route	<i>(provide a map of the route similar to what was provided in Section 2.5.4)</i>
<b>Environmental Compliance and Permitting Plan</b>		
*	Overall land use and environmental permits and approvals strategy	<i>(provide information in level of detail as provided in Section 2.6.1)</i>
*	Gantt format schedule which identifies the sequencing of permit applications and approval activities and critical path. Schedule must be in MM/DD/YY format)	<i>(provide information in level of detail as provided in Section 2.6.1)</i>
*	City Zoning and Land Use Classification	<i>(provide information in level of detail as provided in Section 2.6.2)</i>
*	Discretionary and non-discretionary Land use, environmental and construction permits and approvals	<i>(provide information in level of detail as provided in Section 2.6.3)</i>
*	Listing of Permits and approvals	<i>(provide information in level of detail as provided in Section 2.6.3)</i>
*	Preliminary environmental assessment of the Site (including any pre-existing environmental conditions)	<i>(provide information in level of detail as provided in Section 2.6.4)</i>
<b>Cultural Resource Impacts</b>		
*	Proposer's updated Community Outreach Plan must include a plan that (1) identifies any cultural, historic or natural resources that will be impacted by the Project (2) describes the potential impacts on these	<i>(provide information in level of detail as provided in Section 2.7)</i>



	resources and (3) identifies measures to mitigate such impacts.	
<b>Community Outreach</b>		
*	Detailed Community Outreach Plan	<i>(provide key information from Community Outreach Plan as specified in Section 2.8.1 or provide a link to updated comprehensive Community Outreach Plan)</i>
*	Local community support or opposition	<i>(provide latest comprehensive information)</i>
*	Community outreach efforts	<i>(provide latest comprehensive information)</i>
*	Community benefits	<i>(provide latest comprehensive information)</i>

## 2.9 OPERATIONS AND MAINTENANCE (O&M)

2.9.1 To demonstrate the long-term operational viability of the proposed Project, describe the **planned operations and maintenance**, including:

- Operations and maintenance funding levels, annually, throughout the term of the contract.
- Description of the operational requirements by frequency (daily, weekly, monthly, yearly, as-necessary, run hour interval) and maintenance requirements by frequency (daily, weekly, monthly, yearly, as-necessary, run hour interval).
- A discussion of the staffing levels proposed for the Project and location of such staff. If such staff is offsite, describe response time and ability to control the Project remotely.
- Technology specific maintenance experience records.
- Identification of any O&M providers.
- The expected role of the Proposer (Owner) or outside contractor.
- Scheduling of major maintenance activity.
- Plan for testing equipment.
- Estimated life of Generation and/or Storage Facilities and associated Interconnection Facilities.
- Safety plan, including historical safety records with environmental history records, violations, and compliance plans.
- Security plan.
- Site maintenance plan.
- Substation equipment maintenance plan.

2.9.2 State whether the Proposer would **consider 24-hour staffing**. Explain how this would be done.

2.9.3 Describe the **Proposer’s contingency plan**, including the Proposer’s mitigation plans to address failures. Such information should be described in the Proposal to demonstrate the Project’s reliability with regard to potential operational issues.

2.9.4 Describe if the Proposer will **coordinate their maintenance schedule** for the Project with the Company’s annual planned generation maintenance. See Article 5 of the model RDG PPA.

2.9.5 Describe the **status of any O&M agreements or contracts** that the Proposer is required to secure. Include a discussion of the Proposer's plan for securing a long-term O&M contract.

2.9.6 Provide **examples of the Proposer's experience with O&M services** for other similar projects.

## 2.10 PERFORMANCE STANDARDS

2.10.1 Design and operating information. Provide a **description of the project design**. Description shall include:

- Configuration description, including conceptual or schematic diagrams Overview of the Facility Control Systems – central control and inverter- or resource-level control
- Diagrams approved by a Professional Electrical Engineer registered in the State of Hawai'i, indicated by the presence of the Engineer's Professional seal on all drawings and documents. Including but not limited to:
  - A single-line diagram, relay list, trip scheme and settings of the generating facility, which identifies the Point of Interconnection, circuit breakers, relays, switches, synchronizing equipment, monitoring equipment, and control and protective devices and schemes.
  - A three-line diagram which shows the Point of Interconnection, potential transformer (PT) and current transformer (CT) ratios, and details of the generating facility configuration, including relays, meters and test switches.

2.10.1.1 Provide the projected **hourly annual energy potential production profile of the Facility<sup>7</sup> (24 hours x 365 days, 8760 generation profile)** for the provided NEP RFP Projection.

2.10.1.2 Provide the **sample rate of critical telemetry** (i.e. frequency and voltage) based on inputs to the facility control systems.

2.10.1.3 Provide a description of the Facility's **capability to be grid-forming and have black start capability**.

2.10.1.4 Provide the explanation of the methodology and underlying **information used to derive the Project's NEP RFP Projection**, including the preliminary design of the Facility and the typical meteorological year file used to estimate the Renewable Resource Baseline, as required in Article 6.6 of the applicable Model PV Large RDG PPA and Mid-Tier SFC. The explanation of the methodology should include, but not be limited to, the long-term resource data used, the gross and net generation MWh, and assumptions (loss factors, uncertainty values, any grid or project constraints).

2.10.2 Capability of **Meeting Performance Standards**. The proposed Facility must meet the performance attributes identified in Section 2.1 of the RFP. Provide **confirmation that the proposed Facility will meet the requirements identified** or provide clarification or comments about the Facility's ability to meet the performance standards. Proposals should include sufficient documentation to support the stated claim that the Facility will be able to meet the Performance Standards. The Proposal should include

---

<sup>7</sup> For Paired Projects, the projected hourly annual energy production profile is the projected output from the generating facility without curtailment and before any energy is directed to an energy storage component.

information required to make such a determination in an organized manner to ensure this evaluation can be completed within the evaluation review period.

2.10.3 **Reactive Power Control:** Provide the facility's **ability to meet the Reactive Power Control capabilities**, including Voltage Regulation at the point of interconnection, required in the Performance Standards, including contribution from the inverters of generation and/or storage and means of coordinating the response. Provide the inverter capability curve(s). Confirm ability to provide reactive power at zero active power.

2.10.4 **Ramp Rate** for Generation Facilities: Confirm the ability to meet the ramp rate requirement specified in the Model RDG PPA or Mid-Tier SFC.

2.10.5 **Undervoltage ride-through:** Provide the facility's terminal voltage level(s) and elapsed time at which the facility will disconnect from the utility system during the disturbance, if any. Confirm the ability to meet ride-through requirements and include supporting documentation regarding inverter design, control parameters, etc.

2.10.6 **Overvoltage ride-through:** Provide the facility's terminal voltage level(s) and elapsed time at which the facility will disconnect from the utility system during the disturbance, if any. Confirm the ability to meet ride-through requirements and include supporting documentation regarding inverter design, control parameters, etc.

2.10.7 **Transient stability ride-through:** Provide the facility's ability to stay online during Company System: (1) three-phase fault located anywhere on the Company System and lasting up to \_\_ cycles; and (2) a single line to ground fault located anywhere on the Company System and lasting up to \_\_ cycles. Provide the Facility's ability to withstand subsequent events.

2.10.8 **Underfrequency ride-through:** Provide the facility's terminal frequency level(s) and elapsed time at which the facility will disconnect from the utility system during the disturbance, if any. Confirm the ability to meet ride-through requirements and include supporting documentation regarding inverter design, control parameters, etc.

2.10.9 **Overfrequency ride-through:** Provide the facility's terminal frequency level(s) and elapsed time at which the facility will disconnect from the utility system during the disturbance, if any. Confirm the ability to meet ride-through requirements and include supporting documentation regarding inverter design, control parameters, etc.

2.10.10 **Frequency Response:** Provide the facility's frequency response characteristics as required by the Model RDG PPA or Mid-Tier SFC, including time of response, tunable parameters, alternate frequency response modes and means of implementing such features.

2.10.11 **Auxiliary Power Information:** Proposer must provide the maximum auxiliary power requirements for:

- Start-up
- Normal Operations (from generator)
- Normal Operating Shutdown
- Forced Emergency Shutdown

- Maintenance Outage

2.10.12 **Coordination of Operations:** Provide a description of the control facilities required to coordinate generator operation with and between the Company's System Operator and the Company's System.

- Include a description of the equipment and technology used to facilitate dispatch to the Company and communicate with the Company.
- Include a description of the control and protection requirements of the generator and the Company's System.

2.10.13 **Cycling Capability:** Describe the Facility's ability to cycle on/off and provide limitations.

2.10.14 **Active Power Control Interface:** Describe the means of implementing active power control and the Power Possible, including the contribution to the dispatch signal from paired storage, if any. Provide the Proposer's experience dealing with active power control, dispatch, frequency response, and ride-through.

2.10.15 Provide the details of the **major equipment** (i.e. batteries, inverters, battery management system), including, but not limited to, name of manufacturer, models, key metrics, characteristics of the equipment, and performance specifications.

2.10.16 **Energy Storage performance standards:** For projects that include a storage component, provide additional performance standard descriptions as follows:

- MWh storage output for a full year
- Ramp Rate: Provide the Facility's ramp rate, which should be no more than 2 MW/minute for all conditions other than those under control of the Company System Operator and/or those due to desired frequency response.
- System Response Time – Idle to Design Maximum (minutes)
- Discharge Start-up time (minutes from notification)
- Charge Start-up time (minutes from notification)
- Start and run-time limitations, if any
- Ancillary Services provided, if any (i.e. Spinning Reserves, Non-Spinning Reserves, Regulation Up, Regulation Down, Black Start capability, other )

2.10.17 Provide the description and details of the **grid-charging capabilities of the Facility**. Include a description on the ability to control the charging source.

## 2.11 INTERCONNECTION SUBMITTAL REQUIREMENTS

2.11.1 For projects greater than or equal to 1 MW in size, provide the appropriate completed **Project Interconnection Requirement Study Data Request worksheets** for the proposed technology with the Proposal submission. The worksheets can be found in the "1. Download Documents" tab as Appx B Att 2a or 2b with the respective file names of Project Interconnection Data Request Worksheets (PV Generation) and Project Interconnection Data Request Worksheet (Wind Generation) MSEXcel files. Also provide all **project diagram(s)** with the Proposal submission. **Models for equipment and controls, list(s)** identifying components and **respective files** (for inverters and power plant controller), and **complete documentation with instructions** shall be submitted within the timeframes specified in Section 5.1 of the RFP.<sup>6</sup> Proposers

may also download the Facility Technical Model Requirements and Review Process documentation labelled as Appx B Att 3 from the “1. Download Documents” tab also.

## 2.12 PROVEN TECHNOLOGY

2.12.1 Provide all supporting information for the Company to assess the **commercial and financial maturity of the technology** being proposed. Provide any supporting documentation that shows examples of projects that:

- Use the technology at the scale being proposed
- Have successfully reached commercial operations (for example, by submitting a PPA)
- Demonstrate experience in providing Active Power dispatch

## 2.13 EXPERIENCE AND QUALIFICATIONS

Proposers, its affiliated companies, partners, and/or contractors and consultants are required to demonstrate project experience and management capability to successfully develop and operate the proposed Project.

2.13.1 Provide an **organizational chart** for the Project that lists the project participants and identifies the management structure and responsibilities. In addition to the organizational chart, Proposers must provide a completed table:

- For each of the project participants (including the Proposer, partners, and proposed contractors), **fill out the table below** and provide statements that list the specific experience of the firm in: financing, designing, constructing, interconnecting, owning, operating, and maintaining renewable energy generating or storage facilities, or other projects of similar size and technology, and
- Provide any evidence that the project participants have worked jointly on other projects.

<b>EXPERIENCE:</b>							
In the applicable columns below, include project details (i.e., project name, location, technology, size) and relevant job duties (role/responsibilities) and time (in years/months) spent on the project. List multiple projects if applicable.							
Participant Name:	Financing	Designing	Constructing	Interconnecting	Owning	Operating	Maintaining
1.							
2.							
3.							
...							

2.13.2 Identify those **member(s) of the team** the Proposer is submitting to meet the experience Threshold Requirement and demonstrate the member(s) firm commitment to provide services to the Proposer.

2.13.3 Identify those **members of the team with experience and qualifications**, including affiliates, and their principal personnel who will be involved in the project contracting to sell and deliver energy. If the Proposer consists of multiple parties, such as joint ventures or partnerships, provide this information for each

party, clearly indicating the proposed role of each party, including an ownership chart indicating direct and indirect ownership, and percentage interests in the partnership or joint venture.

2.13.4 Provide a **management chart** which lists the key personnel dedicated to this Project and provide **biographies / resumes** of the key personnel, including position, years of relevant experience, and similar project experience. Provide specifics as they relate to financing of renewable energy projects. Identify architects and engineers or provision to provide same that are licensed to practice in the State of Hawai‘i.

2.13.5 Provide a **listing in the table format below, of all renewable energy generation or energy storage projects** the Proposer has successfully developed or that are currently under construction. Describe the Proposer’s role and responsibilities associated with these projects (lead developer, owner, investor, etc.). Provide the following information as part of the response:

Project Name	Location (City, State)	Technology (wind, PV, hydro, plus storage, etc.)	Size (MW/ MWh)	Commercial Operation Date	Offtaker (if applicable)	Role & Responsibilities
1.						
2.						
3.						
...						

## 2.14 STATE OF PROJECT DEVELOPMENT AND SCHEDULE

2.14.1 Provide a **project schedule in GANTT chart format** with complete **critical path activities** identified for the Proposal from the Notice of Selection of the Proposal to the start of Commercial Operations.

- The **schedule** must include:
  - Interconnection Requirement Study (IRS) assumptions
  - Anticipated contract negotiation period assumptions
  - Regulatory assumptions
  - Anticipated submittal and approval dates for permitting (including but not limited to environmental and archaeological compliance)
  - Siting and land acquisition
  - Cultural Resource implications and mitigation activities
  - Community outreach and engagement activities
  - Energy resource assessment
  - Financing
  - Engineering
  - Procurement
  - Facility construction including construction management events
  - Applicable reporting milestone events specified in the Model RDG PPA or Mid-Tier SFC
  - Testing
  - Interconnection (including engineering, procurement, and construction)
  - Commercial Operations Date
  - All other important elements outside of the direct construction of the Project

- For each project element, list the start and end date (must be in MM/DD/YY format), and include predecessors to clearly illustrate schedule dependencies and durations.
- Proposers must also list and describe critical path activities and milestone events, particularly as they relate to the integration and coordination of the project components and the Company's Electric System. Proposers must ensure that the schedule provided in this section is consistent with the milestone events contained in the RDG PPA or Mid-Tier SFC and/or other agreements.

2.14.2 Describe the **construction execution strategy** including:

- Identification of contracting/subcontracting plans
- Modular construction
- Safety plans<sup>8</sup>
- Quality control and assurance plan
- Labor availability
- Likely manufacturing sites and procurement plans
- Similar projects where these construction methods have been used by the Proposer.

2.14.3 Provide a description of any **project activities that have been performed to date**.

2.14.4 Explain how you plan to reach **safe harbor milestones** (if applicable) and **guaranteed commercial operations**, including durations and dependencies which support this achievement.

### 3.0 PROPOSED CBRE PROGRAM

Provide a detailed description of the CBRE program that will be offered to eligible subscribers, including at a minimum, but not limited to, a discussion of the following. Please refer to the CBRE program non-price criteria in the RFP for elements of the proposed CBRE program that Proposals will be evaluated on.

- Financing Options
  - LMI Subscriber fees and payments
    - Upfront payments
    - Ongoing payments
  - Public funding options
  - Extent to which subscribers will be financially responsible for any facility underperformance
- Percentage of the project's capacity that will be available to subscribers vs. unsubscribed capacity
  - Capacity allocation (%) and other commitments to residential subscribers
  - Capacity allocation (%) and other commitments to low to moderate income ("LMI") subscribers
- Marketing or outreach plans to advertise the proposed project/program to LMI eligible customers
- Strategies for LMI customer retention and maintaining LMI customer participation levels
- Customer protection provisions
- Estimated benefits to LMI customer participants
  - Expected savings
  - Payback periods
  - Payback mechanisms

---

<sup>8</sup> A document that describes the various safety procedures and practices that will be implemented on the Project and how applicable safety regulations, standards, and work practices will be enforced on the Project.

- Other benefits
- Prior experience, specifically relating to community-based renewable energy projects
- Plans for CBRE program administration
  - Strategies for subscriber retention
  - How turnover and churn of subscribers will be handled

## 4.0 MINOR PROPOSAL VARIATION

Proposers submitting a minor variation to their base variation (as allowed in RFP Section 1.8.2 and 1.8.3) **must** provide the **details of the variation in the below section**. In this proposal variation Section 4.0 below, Proposers **must** (1) complete a Proposal Summary identical to Section 2.0 of this Appendix B. The information in this table must reflect the information for the variation being proposed. As specified in Section 2.2.2 above, Proposers submitting a variation must also (2) include a table summarizing the differences between the base variation and the minor variation. Additionally, Proposers must (3) identify all changes to any information provided in response to Sections 2.1 through 3.0 of this Appendix B for the proposal variation. If differences from any section in Sections 2.1 through 3.0 are not identified, the Company will assume that the information contained in the base Proposal (Sections 2.1 through 3.0) also applies to this proposal variation.

### 4.1 RESERVED

#### 4.2.0 PROPOSAL VARIATION SUMMARY TABLE

Replicate the entire Summary Table here. The responses to all line items must reflect the variation being proposed.

#### 4.2.1 through 4.3.0 RESPECTIVE SECTIONS AS NECESSARY

Identify differences to any Appendix B Section 2.1 through 3.0 here.

Note: Section 2.2.2 above requires a table summarizing the differences between the variations, if variations are proposed. For convenience, please duplicate the table summarizing the differences here.



**Certification of Counsel for Proposer**  
**Hawaiian Electric Company, Inc., Maui Electric Company, Ltd, and Hawai'i Electric Light Company, Inc.**

Pursuant to Section 1.7.4 of Hawaiian Electric Company, Inc., Hawai'i Electric Light Company, Inc. and Maui Electric Company, Limited's (each a "Company" and collectively, the "Companies") Request For Proposals for Community-Based Renewable Energy Projects for Low- and Moderate-Income Subscribers, Island of Maui ("RFP"), the Companies may require legal counsel who represent multiple unaffiliated proposers to sign a certification that they have not shared confidential information obtained through the representation of one proposer with any other unaffiliated proposer.

Accordingly, by signing below, I hereby acknowledge, agree and certify that:

(1) in connection with the RFP, I represent the following company that has submitted a proposal(s) for the RFP: \_\_\_\_\_ ("Proposer");

(2) irrespective of any proposer's direction, waiver or request to the contrary, I will not share a proposer's confidential information or the Company's confidential information associated with such proposer, including, but not limited to, a proposer's or Company's negotiating positions, with third parties unaffiliated with Proposer (by contract or organizational structure), including other proposers responding to the RFP;

(3) the Companies may rely on this certification for purposes of the RFP; and

(4) at the conclusion of power purchase agreement negotiations, if any, the Company may require me to sign a certificate certifying that I have not shared a proposer's confidential information or the Company's confidential information associated with such proposer, including, but not limited to, a proposer's or Company's negotiating positions, with third parties unaffiliated with Proposer (by contract or organizational structure), including other proposers responding to the RFP.

\_\_\_\_\_  
Name (print)

\_\_\_\_\_  
Law Firm (if applicable)

\_\_\_\_\_  
Signature

\_\_\_\_\_  
Date

Section 1.7.4 of the RFP provides in relevant part that:

In submitting a Proposal in response to this RFP, each Proposer certifies that the Proposal has been submitted in good faith and without fraud or collusion with any other unaffiliated person or entity. The Proposer shall acknowledge this in the Response Package submitted with its Proposal. Furthermore, in executing the NDA provided as Appendix E, the Proposer agrees on behalf of its Representatives (as defined in the NDA) that the Company's negotiating positions will not be shared with other Proposers or their respective Representatives.

In addition, in submitting a Proposal, a Proposer will be required to provide Company with its legal counsel's written certification in the form attached as Appendix B Attachment 1 certifying in relevant part that irrespective of any proposer's direction, waiver, or request to the contrary, that the attorney will not share a proposer's confidential information associated with such Proposer with others, including, but not limited to, such information such as a Proposer's or Company's negotiating positions. If legal counsel represents multiple unaffiliated proposers whose Proposals are selected for the Final Award Group, such counsel will also be required to submit a

similar certification at the conclusion of power purchase agreement negotiations that he or she has not shared a proposer's confidential information or the Company's confidential information associated with such Proposer with others, including but not limited to, such information as a Proposer's or Company's negotiating positions.

Updated 7/13/2020

**Project Interconnection - Data Request**

**FOR PV GENERATION**

**PROJECT:** \_\_\_\_\_

**DATE:** \_\_\_\_\_

(Nonexclusive Preliminary List)

\*\*\*ALL ITEMS ARE REQUIRED AND ALL RESPONSES MUST BE FILLED UNLESS NOT APPLICABLE.\*\*\*

	Response
1) Please provide a plan map of the Renewable Generation facility. Please indicate the interconnection point to the HECO system.	
2) Please provide the following generation and load information for the Renewable Generation facility:	
a. Gross and net output of the facility	
b. Expected KW and KVAR loads including, but not limited to, generators' auxiliary load curve, process load(s) profile(s), etc.	
c. Expected minimum and maximum MW and MVAR "import from" AND "export to" HECO.	
3) Please provide Single-Line Diagram(s), Three-Line Diagram(s), and Protective Relay List & Trip Schedule for the generation and interconnection facilities:	
a. The Single-line diagram(s) and Three-line diagram (s) should include:	
i. For main and generator step up transformer(s), please show:	
• Transformer voltage and MVA ratings.	
• Transformer impedance(s).	
• Transformer winding connections and grounding. If neutrals are grounded through impedance, please show the impedance value.	
ii. The protective relaying and metering for the generators, transformers, buses, and all other main substation equipment.	
iii. For the potential transformers, please indicate the type, quantity, ratio, and accuracy rating.	
iv. For the current transformers, please indicate the type, quantity, ratio, and accuracy rating, and thermal rating factor.	
v. Auxiliary power devices (e.g. capacitors, reactors, storage systems, etc.) and their rating(s); additional inquiries may be made to obtain technical data for these devices.	
vi. For the interconnection / tie lines (overhead or underground) and the plant's generation system, please provide the following, as applicable:	
• Installation details such as cross-section(s), plan and profiles, etc.	
• Conductor data such as size, insulation, length etc.	
• Continuous and emergency current ratings.	
• Voltage rating (nominal and maximum KV).	
• BIL rating.	
• Positive, negative, and zero-sequence impedances (resistance, reactance, and susceptance)	
• Capacitance or charging current.	
• Short-circuit current capability.	
vii. Include station power for facility and all applicable details.	
viii. All applicable notes pertaining to the design and operation of the facility.	
b. The Protective relay list & trip schedule should list the protected equipment; the relay description, type, style number, quantity, ANSI Device No., and range; and the breaker(s)/switching device(s) tripped, for both the generator protection and the interconnection facilities protection.	
c. Please provide both a paper and an electronic version (e.g. dgn, dxf, or pdf) of the single-line diagram(s) and the protective relay list & trip schedule.	
d. Single-line diagrams should be provided for both the generation plant and the interconnection substation.	

Updated 7/13/2020

**Project Interconnection - Data Request**

**FOR PV GENERATION**

PROJECT: \_\_\_\_\_

DATE: \_\_\_\_\_

(Nonexclusive Preliminary List)

\*\*\*ALL ITEMS ARE REQUIRED AND ALL RESPONSES MUST BE FILLED UNLESS NOT APPLICABLE.\*\*\*

		Response
4)	<b>For the PV Inverter Based Generating Facility, please provide the following data:</b>	
	a. Inverter manufacturer, Type, Size, Impedances. Attach copy of inverter data sheet.	
	b. Power Factor Range Capability	
	c. Inverter Reactive Power Capability Curve	
	d. Auxillary loads (P, Q, Power Factor)	
	e. Inverter's Internal Isolation Transformer Grounding Method, if used (i.e. effectively grounded, resonant grounded, low inductance grounded, high-resistance grounded, low-resistance grounded, ungrounded). If the transformer is not solidly grounded, provide the impedance value for the grounding neutral and the impedance for the isolation transformer.	
	f. Diagram for Inverter's internal isolation transformer	
	g. Switching and service restoration practice	
	h. Protection data (voltage ride-through and trip settings, frequency ride-through and trip settings etc.). Include setpoint and clearing time ranges for voltage and frequency settings.	
	i. Description of harmonic spectrum of inverter injection (order, magnitude)	
5)	<b>Energy Storage System, if applicable</b>	
	a. Operation characteristics	
	b. Voltage level	
	c. Capacity (how long and how much can the battery support)	
	d. Deployment strategy/schedule	
	e. Energy storage system data sheet	
6)	<b>For the PV plant's collector system, please provide the following, as applicable:</b>	
	a. Conductor data such as size, insulation, etc.	
	b. Continuous and emergency current ratings.	
	c. Voltage rating (nominal and maximum kV).	
	d. BIL rating.	
	e. Positive, negative, and zero-sequence impedances (resistance, reactance, and susceptance).	
	f. Capacitance or charging current.	
	g. Short-circuit current capability.	

Updated 7/13/2020

**Project Interconnection - Data Request  
FOR PV GENERATION**

PROJECT: \_\_\_\_\_

DATE: \_\_\_\_\_

(Nonexclusive Preliminary List)

\*\*\*ALL ITEMS ARE REQUIRED AND ALL RESPONSES MUST BE FILLED UNLESS NOT APPLICABLE.\*\*\*

	Response
7) <b>Please provide the following software models that accurately represent the Facility:</b> (For model requirements, refer to the HECO Facility Technical Model Requirements and Review Process and PSCAD Model Requirements Rev.9)	
a. Validated PSS/E load flow model up to the point of interconnection. The PSS/E model shall include the main transformer, collection system, generator step-up transformers, inverter systems, and any other components including capacitor banks, energy storage systems, DVAR, etc. An equivalent representation of the collection system, generator step-up transformers, and inverter systems is acceptable. Documentation on the model shall be provided.	
b. Validated PSS/E dynamic model for the inverter; and other components including energy storage system, DVAR, etc. if applicable. The inverter model shall include the generator/converter, electrical controls, plant-level controller, and protection relays. Generic and Detailed models shall be provided. Documentation on the model(s) shall be provided, including the PSS/E dyre file with model parameters.	
i. Generic models shall parameterize models available within the PSS/E standard model library.	
ii. Detailed models shall be supplied by the vendor/manufacturer as user-written models. The uncompiled source code for the user-written model shall be provided to ensure compatability with future versions of PSS/E. In lieu of the uncompiled source code, a compiled object file and applicable library files shall be provided in PSS/E versions 33 AND 34 format. Updates of the object file compatible with future PSS/E versions must be provided as requested for the life of the project as written in the power purchase agreement. Documentation shall include the characteristics of the model, including block diagrams, values, names for all model parameters, and a list of all state variables.	
c. Validated PSCAD model of the inverter; and other components including energy storage system, DVAR, auxiliary plant controllers, etc. if applicable. Documentation on the model(s) shall be provided. Refer to PSCAD Model Requirements Memo for model requirements.	
d. Overlaid plots validating the performance of the three dynamic models for a three-phase fault. Plots shall include voltage, real and reactive power, real and reactive current.	
e. Validated Aspen Oneliner short circuit model that accurately represents the facility (including energy storage system if applicable), and is valid for all faults conditions anywhere on the Utility system. Documentation on the model(s) shall be provided. (OTHERWISE SEE ADDITIONAL TABS FOR REQUIRED INFORMATION TO MODEL INVERTER AS A GENERATOR OR A VOLTAGE CONTROLLED CURRENT SOURCE)	
8) <b>For the main transformer and generator step-up transformers, please provide:</b>	
a. Transformer voltage and MVA ratings, and available taps. Attach copy of transformer test report or data sheet	
b. The tap settings used.	
c. The LTC Control Scheme.	
d. Transformer winding connections and grounding used. If the transformer is not solidly grounded, provide the impedance value for the grounding method.	
e. Positive, negative, and zero sequence impedance values.	
9) <b>For the circuit breakers and fault-clearing switching devices, including the generator breakers, please provide:</b>	
a. The voltage, continuous current and interrupting capability ratings.	
b. The trip speed (time to open).	

Updated 7/13/2020

**Project Interconnection - Data Request  
FOR PV GENERATION**

PROJECT: \_\_\_\_\_

DATE: \_\_\_\_\_

(Nonexclusive Preliminary List)

\*\*\*ALL ITEMS ARE REQUIRED AND ALL RESPONSES MUST BE FILLED UNLESS NOT APPLICABLE.\*\*\*

		Response
10)	<b>For the power fuses, please provide:</b>	
	a. The manufacturer, type, size, and interrupting capability.	
	b. The minimum melt and total clearing curves.	
11)	<b>For the protective relaying, please provide:</b>	
	a. Data for the CTs used with the relaying including the manufacturer, type of CT, accuracy class, and thermal rating factor.	
	b. Data for the PTs used with the relaying including the manufacturer, type of PT, voltage ratings, and quantity.	

Instructions:

Please fill in the data in the green blanks below

(Note: This does not include the internal isolation transformer, if used)

[1] Maximum rated output power =  kVA

[2] Impedances in **Per Unit** based on kVA from [1]

	R	X
Subtransient =	<input type="text"/>	<input type="text"/>
Transient =	<input type="text"/>	<input type="text"/>
Synchronous =	<input type="text"/>	<input type="text"/>
Negative Sequence =	<input type="text"/>	<input type="text"/>
Zero Sequence =	<input type="text"/>	<input type="text"/>

[3] Neutral impedance (if any) in actual **Ohms**:

R	X
<input type="text"/>	<input type="text"/>

NOTE: These parameters should reflect the inverter response for all types of faults at any point on the electrical system to which the inverter is connected. This includes faults at the inverter output terminals, and also on the 138 kV transmission system. If the stated parameters do not cover this range, please state the adjustments needed to these parameters to accurately represent the inverter response across this range.

These parameters will be used to model the inverter in the Aspen Oneliner program as shown in the sample dialog box below:

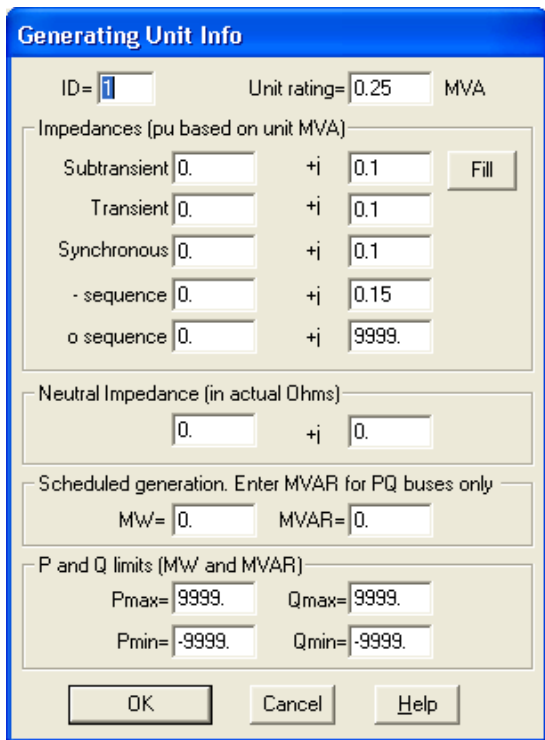

Instructions:

Please fill in the data in the green blanks below

- [1] Internal open circuit voltage  
 Magnitude =  Per Unit  
 Angle =  Degrees
  
- [2] AC Output Current Limit =  Amps

NOTE: These parameters should reflect the inverter response for all types of faults at any point on the electrical system to which the inverter is connected. This includes faults at the inverter output terminals, and also on the 138 kV transmission system. If the stated parameters do not cover this range, please state the adjustments needed to these parameters to accurately represent the inverter response across this range.

These parameters will be used to model the inverter in the Aspen Oneliner program as shown in the sample dialog box below:

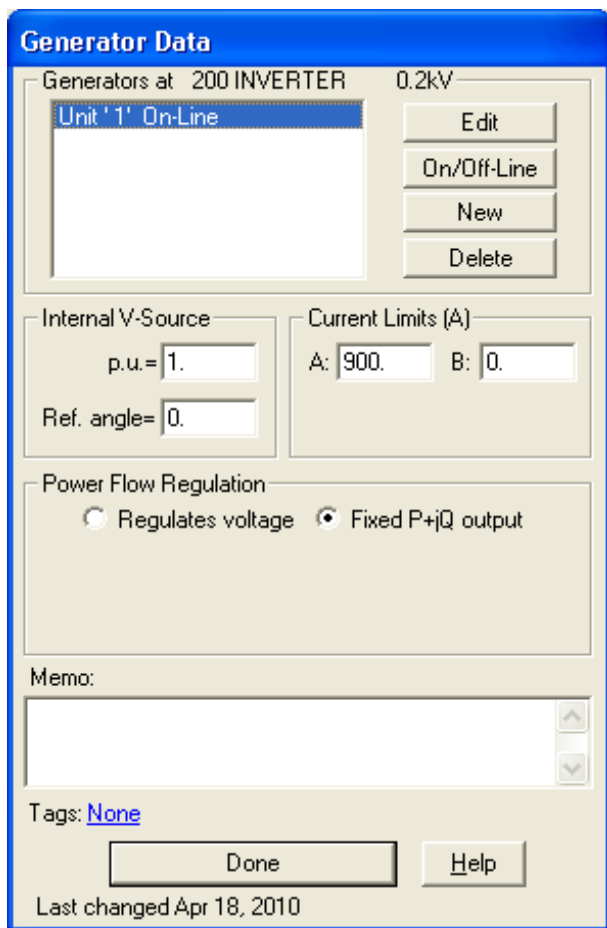



Instructions:

Please fill in the data in the green blanks below

[1] Inverter MVA Rating:  MVA

[2] Voltage-Current Characteristics:

Voltage PU	Current (A)	PF Angle (deg)
<input type="text"/>	<input type="text"/>	<input type="text"/>
<input type="text"/>	<input type="text"/>	<input type="text"/>
<input type="text"/>	<input type="text"/>	<input type="text"/>
<input type="text"/>	<input type="text"/>	<input type="text"/>

[3] Location of Voltage Measurement:

Device Terminal OR  
 Network side of Transformer

[4] Maximum Voltage:  Times prefault value

[5] Minimum Voltage  Per Unit

These parameters will be used to model the inverter in the Aspen Oneliner program as shown in the sample dialog box below:

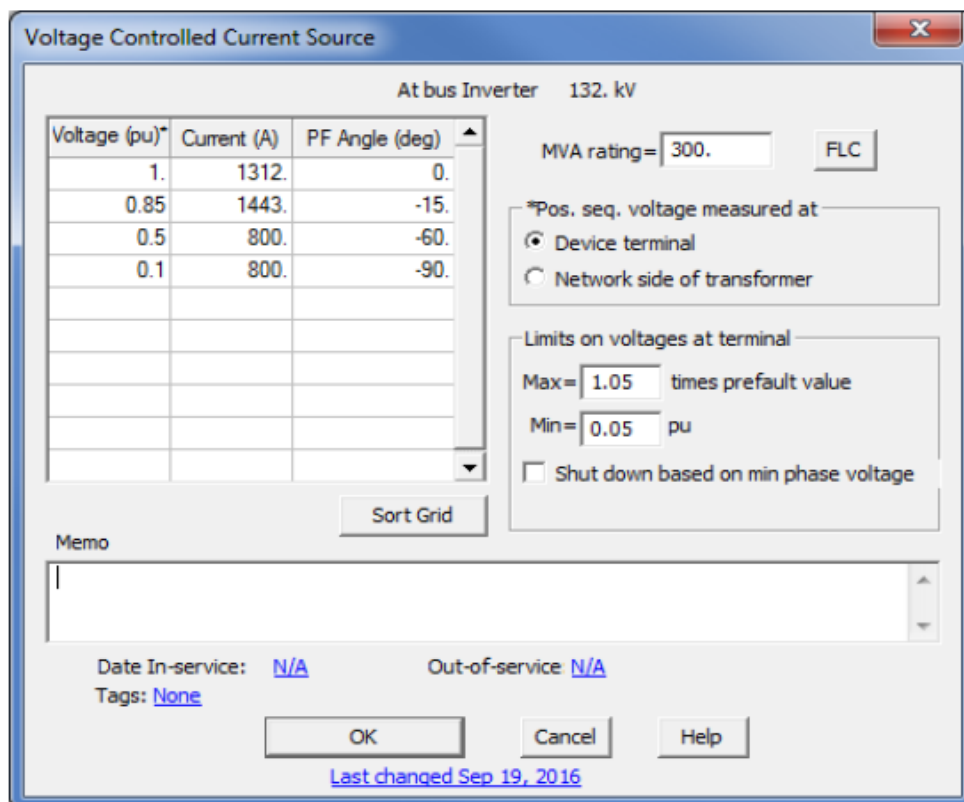

Instructions:

Please fill in the data in the green blanks below

(Note: This is not required if an internal isolation transformer is not used)

[1] Transformer rated power =  kVA

[2] Winding Configuration  
 Inverter Side =  Delta/Wye  
 Customer Side =  Delta/Wye

[2] Impedances in **Per Unit** based on kVA

	R	X
Positive Sequence =	<input type="text"/>	<input type="text"/>
Zero Sequence =	<input type="text"/>	<input type="text"/>

[3] Neutral impedance (if any) in actual **Ohms**:

R	X
<input type="text"/>	<input type="text"/>

These parameters will be used to model the inverter in the Aspen Oneliner program as shown in the sample dialog box below:

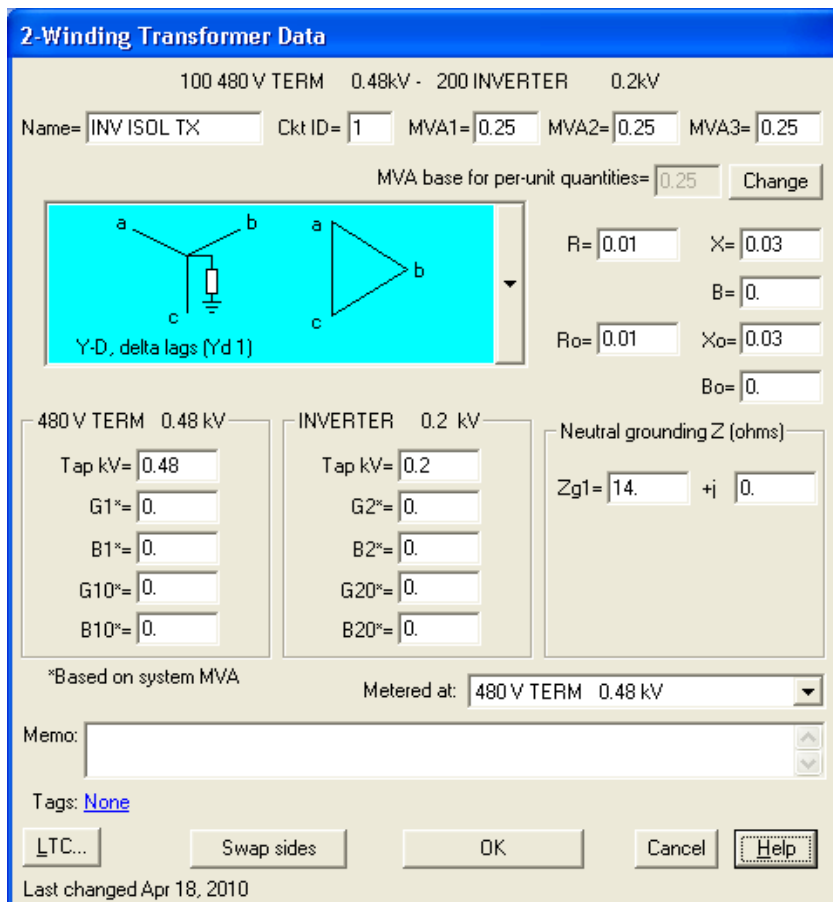

Updated 8/28/2020

**Project Interconnection - Data Request**

**FOR WIND GENERATION**

**PROJECT:** \_\_\_\_\_

**DATE:** \_\_\_\_\_

(Nonexclusive Preliminary List)

\*\*\*ALL ITEMS ARE REQUIRED AND ALL RESPONSES MUST BE FILLED UNLESS NOT APPLICABLE.\*\*\*

	Response
1) Please provide a plan map of the Non-Utility Generation (NUG) facility. Please indicate the interconnection point to the HECO system.	
2) Please provide the following generation and load information for the NUG facility:	
a. Gross and net output of the facility	
b. Expected KW and KVAR loads including, but not limited to, generators' auxiliary load curve, process load(s) profile(s), etc.	
c. Expected minimum and maximum MW and MVAR "import from" AND "export to" HECO.	
3) Please provide Single-Line Diagram(s), Three-Line Diagram(s), and Protective Relay List & Trip Schedule for the generation and interconnection facilities:	
a. The Single-line diagram(s) and Three-line diagram (s) should include:	
i. For main and generator step up transformer(s), please show:	
• Transformer voltage and MVA ratings.	
• Transformer impedance(s).	
• Transformer winding connections and grounding. If neutrals are grounded through impedance, please show the impedance value.	
ii. The protective relaying and metering for the generators, transformers, buses, and all other main substation equipment.	
iii. For the potential transformers, please indicate the type, quantity, ratio, and accuracy rating.	
iv. For the current transformers, please indicate the type, quantity, ratio, and accuracy rating, and thermal rating factor.	
v. Auxiliary power devices (e.g. capacitors, reactors, storage systems, etc.) and their rating(s); additional inquiries may be made to obtain technical data for these devices.	
vi. For the interconnection / tie lines (overhead or underground) and the plant's generation system, please provide the following, as applicable:	
• Installation details such as cross-section(s), plan and profiles, etc.	
• Conductor data such as size, insulation, length etc.	
• Continuous and emergency current ratings.	
• Voltage rating (nominal and maximum KV).	
• BIL rating.	
• Positive, negative, and zero-sequence impedances (resistance, reactance, and susceptance)	
• Capacitance or charging current.	
• Short-circuit current capability.	
vii. Include station power for facility and all applicable details.	
viii. All applicable notes pertaining to the design and operation of the facility.	
b. The Protective relay list & trip schedule should list the protected equipment; the relay description, type, style number, quantity, ANSI Device No., and range; and the breaker(s)/switching device(s) tripped, for both the generator protection and the interconnection facilities protection.	
c. Please provide both a paper and an electronic version (e.g. dgn, dxf, or pdf) of the single-line diagram(s) and the protective relay list & trip schedule.	
d. Single-line diagrams should be provided for both the generation plant and the interconnection substation.	

Updated 8/28/2020

**Project Interconnection - Data Request**

**FOR WIND GENERATION**

**PROJECT:** \_\_\_\_\_

**DATE:** \_\_\_\_\_

(Nonexclusive Preliminary List)

\*\*\*ALL ITEMS ARE REQUIRED AND ALL RESPONSES MUST BE FILLED UNLESS NOT APPLICABLE.\*\*\*

	Response
4) <b>For the Wind Generating Facility, please provide the following data:</b>	
a. Turbine manufacturer, Type, Size, Impedances. Attach copy of turbine data sheet.	
b. Power Factor Range Capability	
c. Turbine Reactive Power Capability Curve	
d. Auxillary loads (P, Q, Power Factor)	
e. Grounding Method (i.e. effectively grounded, resonant grounded, low inductance grounded, high-resistance grounded, low-resistance grounded, ungrounded). If the transformer is not solidly grounded or ungrounded, provide the impedance value for the grounding neutral, if applicable.	
f. Provide grounding diagram.	
g. Switching and service restoration practice	
h. Protection data (voltage ride-through and trip settings, frequency ride-through and trip settings etc.). Include setpoint and clearing time ranges for voltage and frequency settings.	
k. Description of harmonic spectrum of inverter injection (order, magnitude)	
5) <b>Energy Storage System, if applicable</b>	
a. Operation characteristics	
b. Voltage level	
c. Capacity (how long and how much can the battery support)	
d. Deployment strategy/schedule	
e. Energy storage system data sheet	
6) <b>For the Wind plant's collector system, please provide the following, as applicable:</b>	
a. Conductor data such as size, insulation, etc.	
b. Continuous and emergency current ratings.	
c. Voltage rating (nominal and maximum kV).	
d. BIL rating.	
e. Positive, negative, and zero-sequence impedances (resistance, reactance, and susceptance).	
f. Capacitance or charging current.	
g. Short-circuit current capability.	

Updated 8/28/2020

**Project Interconnection - Data Request**

**FOR WIND GENERATION**

**PROJECT:** \_\_\_\_\_

**DATE:** \_\_\_\_\_

**(Nonexclusive Preliminary List)**

**\*\*\*ALL ITEMS ARE REQUIRED AND ALL RESPONSES MUST BE FILLED UNLESS NOT APPLICABLE.\*\*\***

	Response
7) <b>Please provide the following software models that accurately represent the Facility:</b> (For model requirements, refer to the HECO Facility Technical Model Requirements and Review Process and PSCAD Model Requirements Rev.9)	
a. Validated PSS/E load flow model up to the point of interconnection. The PSS/E model shall include the main transformer, collection system, generator step-up transformers, wind turbines, and any other components including capacitor banks, energy storage systems, DVAR, etc. An equivalent representation of the collection system, generator step-up transformers, and turbines is acceptable. Documentation on the model shall be provided.	
b. Validated PSS/E dynamic model for the wind turbine; and other components including energy storage system, DVAR, etc. if applicable. The wind turbine model shall include the generator/converter, electrical controls, plant-level controller, protection relays, and mechanical systems that impact its electrical performance. Generic and Detailed models shall be provided. Documentation on the model(s) shall be provided, including the PSS/E dyre file with model parameters.	
i. Generic models shall parameterize models available within the PSS/E standard model library.	
ii. Detailed models shall be supplied by the vendor/manufacturer as user-written models. The uncompiled source code for the user-written model shall be provided to ensure compatibility with future versions of PSS/E. In lieu of the uncompiled source code, a compiled object file and applicable library files shall be provided in PSS/E versions 33 AND 34 format. Updates of the object file compatible with future PSS/E versions must be provided as requested for the life of the project as written in the power purchase agreement. Documentation shall include the characteristics of the model, including block diagrams, values, names for all model parameters, and a list of all state variables.	
c. Validated PSCAD model of the wind turbine; and other components including energy storage system, DVAR, etc. if applicable. Documentation on the model(s) shall be provided. Refer to PSCAD Technical Memo for model requirements.	
d. Overlaid plots validating the performance of the three dynamic models for a three-phase fault. Plots shall include voltage, real and reactive power, real and reactive current.	
e. Validated Aspen Oneliner short circuit model that accurately represents the facility (including energy storage system if applicable), and is valid for all faults conditions anywhere on the Utility system. Documentation on the model(s) shall be provided. (OTHERWISE SEE ADDITIONAL TABS FOR REQUIRED INFORMATION TO MODEL INVERTER)	
8) <b>For the main transformer and generator step-up transformers, please provide:</b>	
a. Transformer voltage and MVA ratings, and available taps. Attach copy of transformer test report or data sheet	
b. The tap settings used.	
c. The LTC Control Scheme.	
d. Transformer winding connections and grounding used. If the transformer is not solidly grounded, provide the impedance value for the grounding method.	
e. Positive, negative, and zero sequence impedance values.	
9) <b>For the circuit breakers and fault-clearing switching devices, including the generator breakers, please provide:</b>	
a. The voltage, continuous current and interrupting capability ratings.	
b. The trip speed (time to open).	

Updated 8/28/2020

**Project Interconnection - Data Request**

**FOR WIND GENERATION**

**PROJECT:** \_\_\_\_\_

**DATE:** \_\_\_\_\_

(Nonexclusive Preliminary List)

**\*\*\*ALL ITEMS ARE REQUIRED AND ALL RESPONSES MUST BE FILLED UNLESS NOT APPLICABLE.\*\*\***

		Response
10)	<b>For the power fuses, please provide:</b>	
	a. The manufacturer, type, size, and interrupting capability.	
	b. The minimum melt and total clearing curves.	
11)	<b>For the protective relaying, please provide:</b>	
	a. Data for the CTs used with the relaying including the manufacturer, type of CT, accuracy class, and thermal rating factor.	
	b. Data for the PTs used with the relaying including the manufacturer, type of PT, voltage ratings, and quantity.	

Instructions:

Please fill in the data in the green blanks below

(Note: This does not include the internal isolation transformer, if used)

[1] Maximum rated output power =  kVA

[2] Impedances in **Per Unit** based on kVA from [1]

	R	X
Subtransient =	<input type="text"/>	<input type="text"/>
Transient =	<input type="text"/>	<input type="text"/>
Synchronous =	<input type="text"/>	<input type="text"/>
Negative Sequence =	<input type="text"/>	<input type="text"/>
Zero Sequence =	<input type="text"/>	<input type="text"/>

[3] Neutral impedance (if any) in actual **Ohms**:

R	X
<input type="text"/>	<input type="text"/>

NOTE: These parameters should reflect the inverter response for all types of faults at any point on the electrical system to which the inverter is connected. This includes faults at the inverter output terminals, and also on the 138 kV transmission system. If the stated parameters do not cover this range, please state the adjustments needed to these parameters to accurately represent the inverter response across this range.

These parameters will be used to model the inverter in the Aspen Oneliner program as shown in the sample dialog box below:

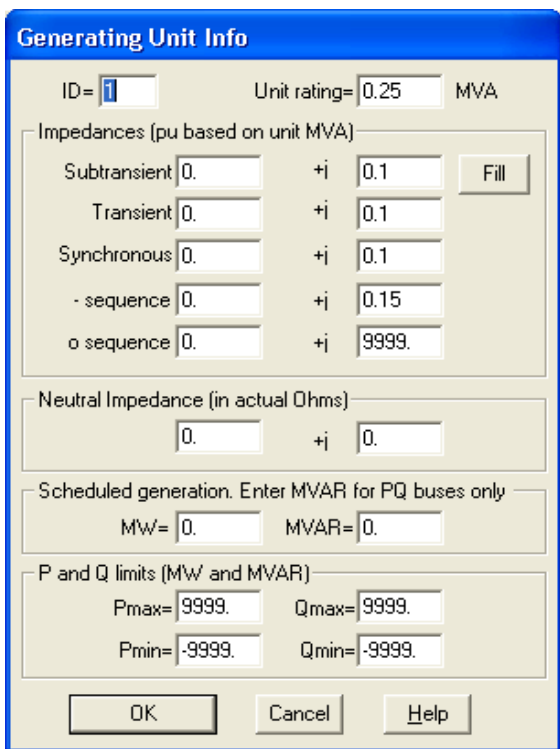

Instructions:

Please fill in the data in the green blanks below

- [1] Internal open circuit voltage  
 Magnitude =  Per Unit  
 Angle =  Degrees
- [2] AC Output Current Limit =  Amps

NOTE: These parameters should reflect the inverter response for all types of faults at any point on the electrical system to which the inverter is connected. This includes faults at the inverter output terminals, and also on the 138 kV transmission system. If the stated parameters do not cover this range, please state the adjustments needed to these parameters to accurately represent the inverter response across this range.

These parameters will be used to model the inverter in the Aspen Oneliner program as shown in the sample dialog box below:

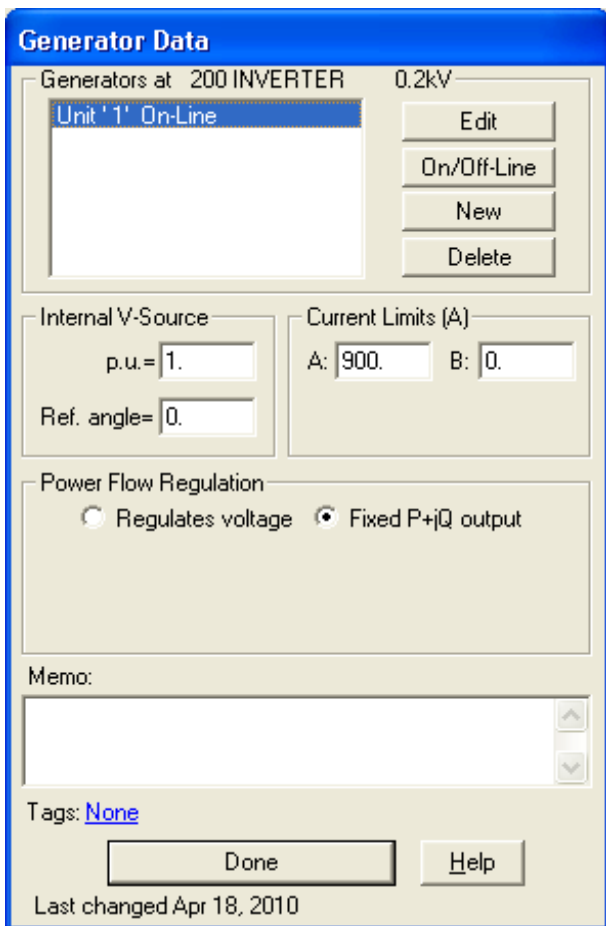



Instructions:

Please fill in the data in the green blanks below

[1] Inverter MVA Rating:  MVA

[2] Voltage-Current Characteristics:

Voltage PU	Current (A)	PF Angle (deg)
<input type="text"/>	<input type="text"/>	<input type="text"/>
<input type="text"/>	<input type="text"/>	<input type="text"/>
<input type="text"/>	<input type="text"/>	<input type="text"/>
<input type="text"/>	<input type="text"/>	<input type="text"/>

[3] Location of Voltage Measurement:

Device Terminal OR  
 Network side of Transformer

[4] Maximum Voltage:  Times prefault value

[5] Minimum Voltage  Per Unit

These parameters will be used to model the inverter in the Aspen Oneliner program as shown in the sample dialog box below:

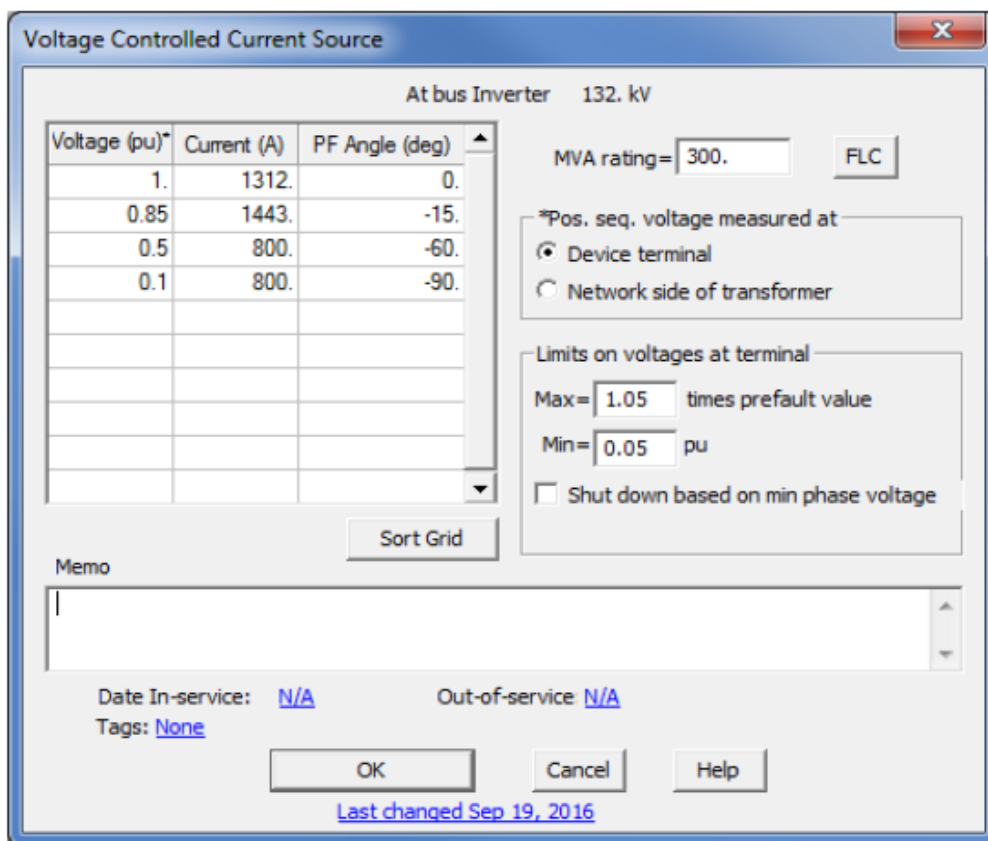

Instructions:

Please fill in the data in the green blanks below

(Note: This is not required if an internal isolation transformer is not used)

[1] Transformer rated power =  kVA

[2] Winding Configuration  
 Inverter Side =  Delta/Wye  
 Customer Side =  Delta/Wye

[2] Impedances in **Per Unit** based on kVA  
 Positive Sequence = 

	R	X

  
 Zero Sequence = 

[3] Neutral impedance (if any) in actual **Ohms**:  

	R	X

These parameters will be used to model the inverter in the Aspen Oneliner program as shown in the sample dialog box below:

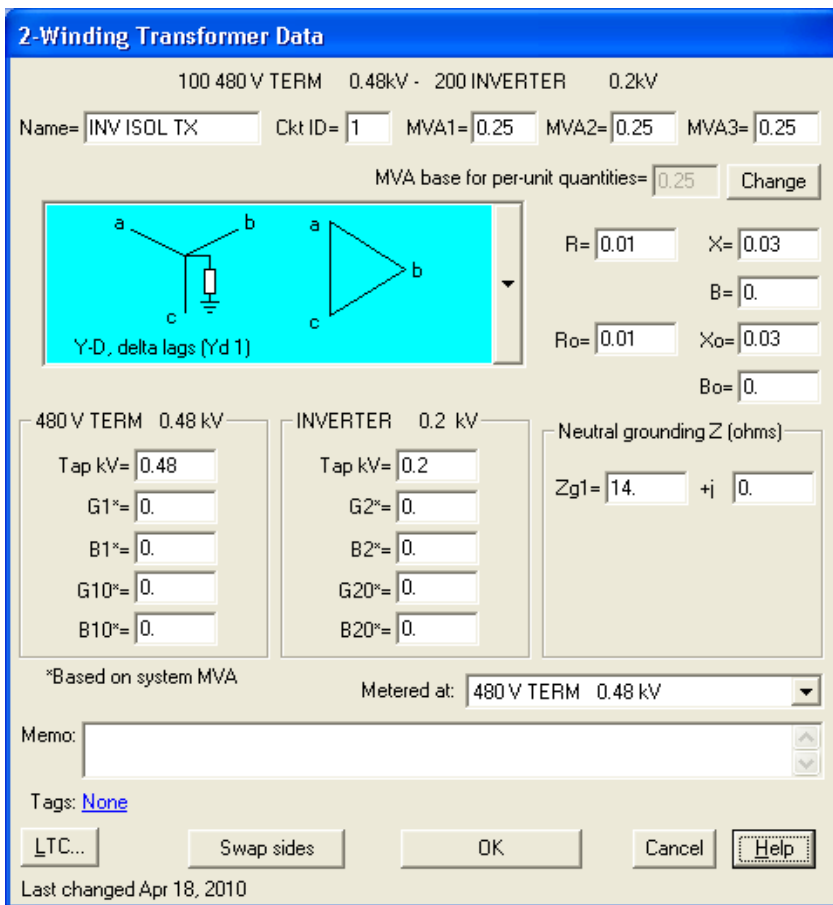

# HECO FACILITY TECHNICAL MODEL REQUIREMENTS AND REVIEW PROCESS

---

March 17, 2020

## Table of Contents

FACILITY TECHNICAL MODEL REQUIREMENTS AND REVIEW PROCESS.....	0
1 INTRODUCTION .....	1
2 FACILITY TECHNICAL MODEL REQUIREMENTS.....	2
2.1 General requirements for all technical models .....	2
2.2 Requirements for generation facility PSCAD model .....	3
2.3 Requirements for generation facility generic PSS/E power flow model .....	3
2.4 Requirements for generation facility user defined PSS/E dynamic model .....	3
2.5 Requirements for generation facility user defined PSS/E dynamic model .....	4
2.6 Requirements for generation facility ASPEN model .....	5
3 GENERATION FACILITY TECHNICAL MODEL REVIEW PROCESS .....	6
3.1 Model review in PSCAD .....	6
3.2 Model review in PSS/E.....	6
4 TYPICAL ISSUES IDENTIFIED FROM THE FACILITY MODEL DURING THE PAST RFP PROCESS ...	8
REFERENCE .....	9
APPENDIX A: SAMPLE OVERLAID GENERATION FACILITY TECHNICAL MODEL OUTPUT PLOT FOR THREE-PHASE FAULT .....	10
APPENDIX B: SAMPLE TEST SYSTEM EQUIVALMENT IMPEDANCE INFORMATION.....	12

# 1 INTRODUCTION

---

This document summarizes requirements of generation facility technical model submittals for request for proposals for variable renewable dispatchable generation and energy storage and describes the review process for model submittals.

## 2 FACILITY TECHNICAL MODEL REQUIREMENTS

---

To fully investigate impacts of the proposed generation facility on Hawaiian Electric's system and correctly identify any mitigation measures, the proposed generation facility technical model, along with related technical documents, will need to be submitted as part of the project interconnection review and prior to the Interconnection Requirements Study (IRS). The generation facility technical model includes:

1. PSCAD model
2. Generic PSS/E power flow model
3. User defined PSS/E dynamic model
4. Generic PSS/E dynamic model, and
5. ASPEN model

Along with the technical models, following documents should also be submitted for review:

6. User manual for all technical models
7. Generation facility one-line diagram
8. Generation unit manufacturer datasheet
9. Generation unit reactive power capability curve
10. Overlaid generation facility technical model output data for three-phase fault and single-phase fault. (Sample plots are shown in Appendix A)

### 2.1 General requirements for all technical models

All technical models need to represent the whole generation facility, not only a generation unit such as one inverter. At minimum, the following equipment shall be included in the generation facility model:

1. Generation unit, such as inverter with DC side model, rotation machine with model of exciter and governor.
2. Step up transformer
3. Collection system
4. Main interconnection transformer, or GSU, with its tap changer if applicable
5. Grounding transformer
6. Conductor
7. Var compensation device, such as cap bank or STATCOM, if applicable
8. Power plant controller (not for ASPEN model)
9. Documentation
10. Gen-tie line (as applicable)

An equivalent representation of the collection system, generator step-up transformers, and inverter systems is acceptable.

## 2.2 Requirements for generation facility PSCAD model

In addition to the general requirements mentioned above, the generation facility PSCAD model shall satisfy requirements as described in the document “PSCAD Model Requirements Rev. 9” provided by Hawaiian Electric.

## 2.3 Requirements for generation facility generic PSS/E power flow model

The generation facility PSS/E power flow model shall be provided for both PSS/E version 33 and version 34. Besides the general requirements mentioned above, the following modeling data shall be provided in the model:

1. Conductor
  - a. Impedance, both positive sequence and zero sequence
  - b. Rating: Rating A – normal rating, and Rating B – emergency rating
2. Transformer
  - a. Nominal voltages of windings
  - b. Impedance data: specified R and X
  - c. Tap ratios
  - d. Min and Max tap position limits
  - e. Number of tap positions
  - f. Regulated bus
  - g. Ratings: Rate A – normal rating; Rate B – emergency rating
  - h. Winding configuration
3. Reactive power compensation, if applicable
  - a. Fixed Shunts: G-Shunt (MW), B-Shunt (MVAR)
  - b. Switched Shunts: Voltage limits (V<sub>hi</sub> and V<sub>low</sub>), mode of operation (fixed, discrete, continuous), regulated bus, Binit (MVAR), steps and step size (MVAR)
4. Generation unit
  - a. P<sub>max</sub>
  - b. P<sub>min</sub>
  - c. Q<sub>max</sub>
  - d. Q<sub>min</sub>
  - e. Name plate MVA
  - f. Transformer data: R Tran, X Tran, and Gentap.
  - g. Voltage control point

## 2.4 Requirements for generation facility user defined PSS/E dynamic model

The submitted user defined PSS/E dynamic model should meet the following requirements:

1. The generation facility PSS/E dynamic model shall be provided for both PSS/E version 33 and version 34.
2. The project shall be modeled at full output per the project’s Interconnection Request.
3. User defined dynamic models must accurately model all the relevant control modes and characteristics of the equipment, such as:

- a. All available voltage/reactive power control modes
  - b. Frequency/governor response control modes
  - c. Voltage and frequency ride-through characteristics
  - d. Power plant controller or group supervisory functionality
  - e. Appropriate aggregate modeling capability
  - f. Charging mode if applicable (e.g., for a battery energy storage device)
4. Dynamic model source code (.flx) or dynamic linked library (.dll), and PSS/E dyr file shall be provided.
  5. User defined dynamic model plant-specific settings shall comply with requirements listed in the Power Purchase Agreement, including ride-through thresholds and other specified control settings if applicable.
  6. User defined dynamic models related to individual units shall be editable in the PSS/E graphic user interface. All model parameters (CONS, ICONS, and VARS) shall be accessible and shall match the description in the model's accompanying documentation.
  7. User defined dynamic models shall have all their data reportable in the "DOCU" listing of dynamics model data, including the range of CONS, ICONS, and VARS numbers. Models that apply to multiple elements (e.g., park controllers) shall also be fully formatted and reportable in DOCU.
  8. User defined dynamic models shall be capable of correctly initializing and run through the simulation throughout the range of expected steady state starting conditions without additional manual adjustments.
  9. User defined dynamic models shall be capable of allowing all documented (in the model documentation) modes of operation without error.
  10. User defined dynamic model shall be accompanied by the following documentation:
    - a. A user's guide for each model
    - b. Appropriate procedures and considerations for using the model in dynamic simulations
    - c. Technical description of characteristics of the model
    - d. Block diagram for the model, including overall modular structure and block diagrams of any sub-modules
    - e. List of plant-specific settings, which may include:
      - i. Ride-through thresholds and parameters
      - ii. Plant-level voltage controller settings
      - iii. Power ramp rate settings
      - iv. ICON flag parameters for specific control modes
      - v. Deadbands
      - vi. Initial State of Charge (SOC)
    - f. Values, names and detailed explanation for all model parameters
    - g. List of all state variables, including expected ranges of values for each variable

## 2.5 Requirements for generation facility generic PSS/E dynamic model

The submitted generic PSS/E dynamic model should meet the following requirements:

1. All generic PSS/E dynamic models must be standard library models in PSS/E.



2. The generation facility PSS/E dynamic model shall be provided for both PSS/E version 33 and version 34.
3. The project shall be modeled at full output per the project's Interconnection Request.
4. Generic dynamic models must accurately model all the relevant control modes and characteristics of the equipment, such as:
  - a. All available voltage/reactive power control modes
  - b. Frequency/governor response control modes
  - c. Voltage and frequency ride-through characteristics
  - d. Power plant controller or group supervisory functionality
  - e. Appropriate aggregate modeling capability
  - f. Charging mode if applicable (e.g., for a battery energy storage device)
5. PSS/E dyr file shall be provided.
6. Generic dynamic models' plant-specific settings should comply with requirements listed in the Power Purchase Agreement, including ride-through thresholds and other specified control settings if applicable.
7. Generic dynamic models shall be capable of correctly initializing and run through the simulation throughout the range of expected steady state starting conditions without additional manual adjustments.
8. Generic dynamic models shall be accompanied by the following documentation:
  - a. A user's guide for each model
  - b. Appropriate procedures and considerations for using the model in dynamic simulations
  - c. Technical description of characteristics of the model
  - d. List of plant-specific settings, which may include:
    - i. Ride-through thresholds and parameters
    - ii. Plant-level voltage controller settings
    - iii. Power ramp rate settings
    - iv. ICON flag parameters for specific control modes
    - v. Deadbands
    - vi. Initial State of Charge (SOC)

## 2.6 Requirements for generation facility ASPEN model

Besides the general requirements, validation results of single phase and three-phase fault current from the generation unit represented in the generation facility ASPEN model shall be provided.

## 3 GENERATION FACILITY TECHNICAL MODEL REVIEW PROCESS

---

To review the generation facility technical model, the following procedures are performed in the PSCAD and PSS/E environment. A review of the results will be documented and provided to the Customer for confirmation of model acceptance or further model updates.

### 3.1 Model review in PSCAD

- 1) Review model data against “Technical memo PSCAD requirements V5.pdf” provided by Hawaiian Electric. In this step, it will be determined whether the model is complete, generation facility settings are according to the Power Purchase Agreement, and if the model can be compiled and run without any error.
- 2) Initialization test:  
In this step, the generation facility PSCAD model will be determined whether the model initialization is acceptable. Hawaiian Electric requires that:
  - a. The PSCAD model shall initialize as quickly as possible (e.g. <1-3 seconds) to user defined terminal conditions.
  - b. Project PSCAD model shall initialize properly and that the same power flow and voltage conditions shall be observed between the PSCAD and PSS/E models after initialization.
- 3) Voltage and frequency ride-through tests:  
In this step, the generation facility PSCAD model ride-through performance will be reviewed by performing voltage and frequency ride-through simulations in PSCAD. The review will focus on the generation facility model dynamic response during and after ride-through and generation facility trip time.
- 4) Fault simulation tests:  
Two types of fault tested at the Point of Interconnection bus of the generation facility will be performed in this step.
  - i) 3-phase to ground fault with 6-cycle clearing time (same as the PSS/E ring down model test described in the following section).
  - ii) 1-phase to ground fault simulation with 6-cycle clearing time.

In this test, fault current contribution from the generation facility observed in the simulation will be reviewed by comparing it against the generation facility technical document.

### 3.2 Model review in PSS/E

- 1) Model data review:  
Review model data based on the requirements for PSS/E power flow and dynamic model provided by Hawaiian Electric. In this step, the review determines whether the model is complete, generation facility settings is according to the PPA, and model can be compiled and run without any error.
- 2) Flat start test:

PSS/E models shall initialize correctly and be capable of successful “flat start” testing using the 20 Second No-Fault simulation: This test consists of a 20 second simulation with no disturbance applied.

3) Ring down test:

PSS/E models shall initialize correctly and be capable of successful “ring down” testing using the 60 Second Disturbance Simulation: This test consists of the application of a 3-phase fault for 6 cycles at POI bus, followed by removal of the fault without any lines being tripped. The simulation is run for 60 seconds to allow the dynamics to settle.

4) Voltage and frequency ride-through tests:

In this step, the generation facility PSS/E model ride-through performance will be reviewed by performing voltage and frequency ride-through simulation in PSS/E. The review will focus on the generation facility model dynamic response during and after ride-through and generation facility trip time.

## 4 TYPICAL ISSUES IDENTIFIED FROM THE FACILITY MODEL SUBMITTALS DURING THE PAST RFP PROCESS

---

### 1. Missing documentation

Only generation technical facility models are submitted, but no model user manual or any other documentation. Without model documentation, it is very difficult to know the correct procedures of using the technical models and identifying issues during the review.

### 2. Model incompleteness

Often, the model of a single generation unit, such as an inverter, is submitted instead of model of the whole generation facility, which is insufficient. The model of the generation facility should include models for all equipment listed in the section of “General requirements for all technical models”.

### 3. Settings in the model

Type issues in this category are:

- The PSCAD and PSS/E model ride-through settings are not consistent with the settings defined in the Power Purchase Agreement.
- Generation MW is not set as defined.
- Model is set for 50 Hz instead of 60 Hz

### 4. Model function issues

Some models do not function as expected during different test scenarios. For example:

- Fault current contribution from the generation facility is higher than what is described in the generation facility datasheet
- Generation level is not stable as settings during the initialization test
- Long time oscillation observed in the ringdown test
- Ride-through performance does not reach requirements defined in the Power Purchase Agreement

## REFERENCE

---

- [1] New England Iso Planning procedure – Interconnection planning procedure for generation and elective transmission upgrades
- [2] ERCOT Planning Guide, 2019
- [3] PJM MOD-032 Steady State, Dynamics, and Short Circuit Modeling Data Requirements and Reporting Procedures Document

## APPENDIX A: SAMPLE OVERLAID GENERATION FACILITY TECHNICAL MODEL OUTPUT PLOT FOR THREE-PHASE FAULT

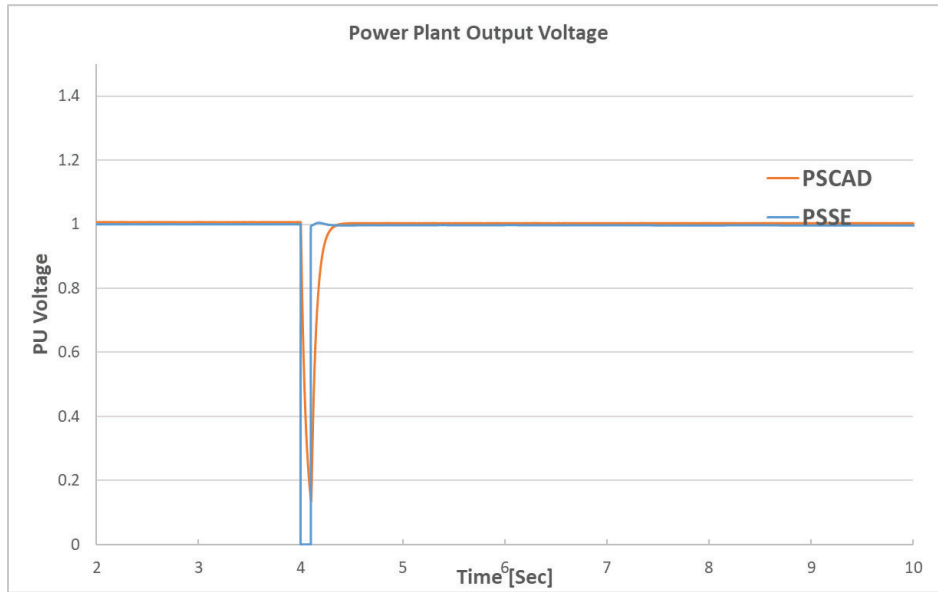

Figure 1: Overlaid plot for power plant voltage

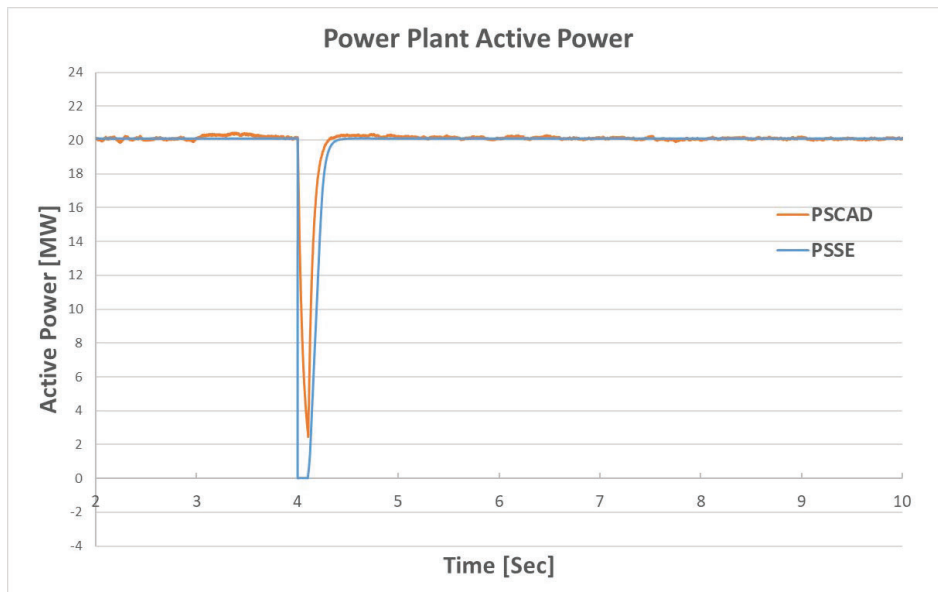

Figure 2: Overlaid plot for power plant active power generation

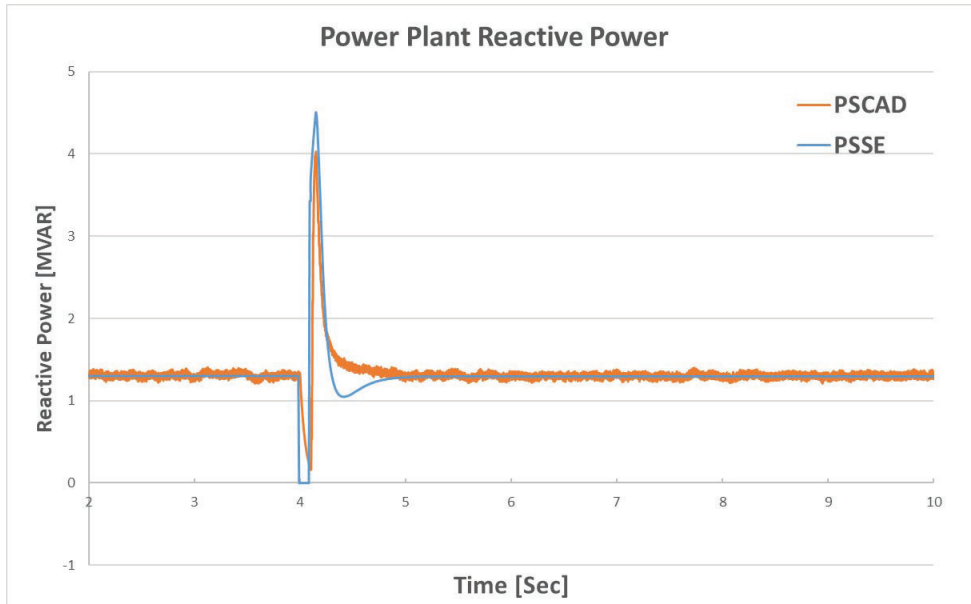

Figure 3: Overlaid plot for power plant reactive power generation

## APPENDIX B: SAMPLE TEST SYSTEM TOPOLOGY INFORMATION

On weak grids such as island systems, it is important to test the models using a representative high Thevenin equivalent impedance.

A typical topology of testing circuit which represents Hawaiian Electric system for 46 kV project is shown in Figure 4. Sample 46 kV Thevenin equivalent impedance is available upon request for model testing.

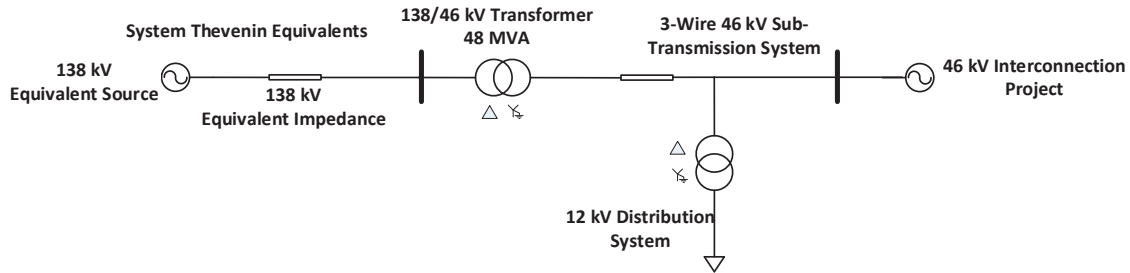

Figure 4: Testing circuit single line diagram for 46 kV project

A typical topology of testing circuit which represents Hawaiian Electric system for 138 kV project is shown in Figure 5. Sample 138 kV Thevenin equivalent impedance is available upon request for model testing.

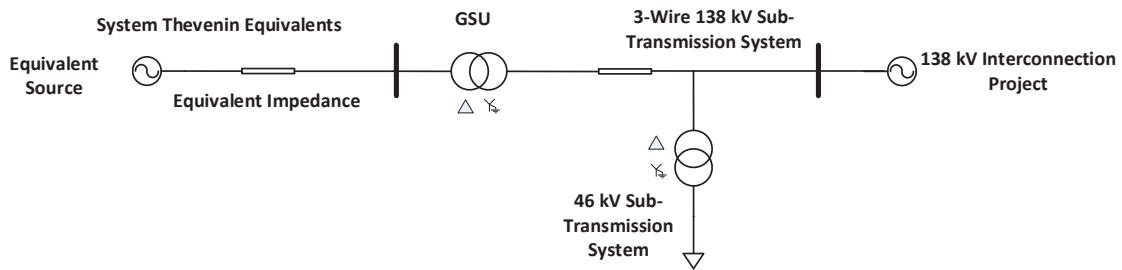

Figure 5: Testing circuit single line diagram for 138 kV project



## PSCAD Model Requirements Rev. 9

**Date:** May 8, 2020  
**Prepared By:** Andrew L. Isaacs  
Lukas Unruh  
Garth Irwin

**This document includes the following attachments:**

**Attachment #1: PSCAD Model Test Checklist**

**Attachment #2: PSCAD Model Requirements Supplier Checklist**

*Electranix makes no representations or warranties of any kind concerning this document, whether express, implied, statutory, or other. This includes, without limitation, warranties of title, merchantability, fitness for a particular purpose, non-infringement, absence of latent or other defects, accuracy, or the presence or absence of errors, whether or not known or discoverable. Electranix will not be held liable for any direct, special, indirect, incidental, consequential, punitive, exemplary, or other losses, costs, expenses, or damages arising out of use of this document or any material herein, even if Electranix has been advised of the possibility of such losses, costs, expenses, or damages.*

Copyright PSCAD Model Requirements Supplier Checklist © 2020 by Electranix Corporation. Please contact [info@electranix.com](mailto:info@electranix.com) for information regarding use or modification of this document.

12-75 Scurfield Blvd.  
Winnipeg, MB, Canada, R3Y 1P6  
[www.electranix.com](http://www.electranix.com)

**ELECTRANIX**  
SPECIALISTS IN POWER SYSTEM STUDIES

This work is licensed under the Creative Commons Attribution 4.0 International License. To view a copy of this license, visit <http://creativecommons.org/licenses/by/4.0/> or send a letter to Creative Commons, PO Box 1866, Mountain View, CA 94042, USA.

### Introduction

Specific model requirements for a PSCAD study depend on the type of study being done. A study with a scope covering weak system interconnections, ride-through evaluation, short term<sup>1</sup> event response, and fast control interaction with nearby devices (for example) would require a model which has the following characteristics. Some specialty studies may require other features. Refer to “Attachment #1: PSCAD Model Test Checklist” and “Attachment #2: PSCAD Model Requirements Supplier Checklist”, appended to this document, for additional information on how these requirements may be applied.

### Model Accuracy Features

For the model to be sufficiently accurate, it must:

- A. *Represent the full detailed inner control loops of the power electronics.* The model cannot use the same approximations classically used in transient stability modeling, and should fully represent all fast inner controls, as implemented in the real equipment. Models which embed the actual hardware code into a PSCAD component are currently wide-spread, and this is the recommended type of model.<sup>2</sup>
- B. *Represent all control features pertinent to the type of study being done.* Examples include external voltage controllers, plant level controllers, customized PLLs, ride-through controllers, SSCI damping controllers and others. As in point A, actual hardware code is recommended to be used for most control and protection features. Operating modes that require system specific adjustment should be user accessible. Plant level voltage control should be represented along with adjustable droop characteristics. If multiple plants are controlled by a common controller, this functionality should be included.
- C. *Represent all pertinent electrical and mechanical configurations.* This includes any filters and specialized transformers. There may be other mechanical features such as gearboxes, pitch controllers, or others which should be modelled if they impact electrical performance within the timeframe of the study. Any control or dynamic features of the actual equipment which may influence behaviour in the simulation period which are not represented or which are approximated should be clearly identified.

---

<sup>1</sup> Example analysis periods could be 2 to 10 seconds from fault inception. Some studies could require longer periods.

<sup>2</sup> The model must be a full IGBT representation (preferred), or may use a voltage source representation that approximates the IGBT switching but maintains full detail in the controls. A three phase sinusoidal source representation is not acceptable. Models manually translated block-by-block from MATLAB or control block diagrams may be unacceptable because the method used to model the electrical network and interface to the controls may not be accurate, or portions of the controls such as PLL circuits or protection circuits may be approximated or omitted. Note that firmware code may be directly used to create an extremely accurate PSCAD model of the controls. The controller source code may be compiled into DLLs or binaries if the source code is unavailable due to confidentiality restrictions.

It is not recommended to assemble the model using standard blocks available in the PSCAD master library, as approximations are usually introduced, and specific implementation details for important control blocks may be lost. In addition, there is a significant risk that errors will be introduced in the process of manually assembling the model. For this type of manually assembled model, (not using a direct “real code” embedding process), extra care is required, and validation is required.

- D. *Have all pertinent protections modeled in detail for both balanced and unbalanced fault conditions.* Typically this includes various OV and UV protections (individual phase and RMS), frequency protections, DC bus voltage protections, converter overcurrent protections, and often other inverter specific protections. As in point A, actual hardware code is recommended to be used for these protection features.
- E. *Be configured to match expected site-specific equipment settings.* Any user-tunable parameters or options should be set in the model to match the equipment at the specific site being evaluated, as far as they are known. Default parameters may not be appropriate.

#### *Model Usability Features*

In order to allow study engineers to perform system analysis using the model, the PSCAD model must:

- F. *Have control or hardware options which are pertinent to the study accessible to the user.* Examples of this could include protection thresholds, real power recovery ramp rates, or SSCI damping controllers.<sup>3</sup> Diagnostic flags (eg. flags to show control mode changes or which protection has been activated) should be visible to aid in analysis.
- G. *Be accurate when running at a simulation time step of 10  $\mu$ s or higher.* Often, requiring a smaller time step means that the control implementation has not used the interpolation features of PSCAD, or is using inappropriate interfacing between the model and the larger network. Lack of interpolation support introduces inaccuracies into the model at larger simulation time-steps. In cases where the IGBT switching frequency is so high that even interpolation does not allow accurate switching representation at 10  $\mu$ s (eg. 40 kHz), an average source approximation of the inverter switching may be used to allow a larger simulation time step<sup>2</sup>.
- H. *Operate at a range of simulation time steps.* The model should not be restricted to operating at a single time step, but should be able to operate within a range (eg. 10  $\mu$ s – 20  $\mu$ s)
- I. *Have the ability to disable protection models.* Many studies result in inadvertent tripping of converter equipment, and the ability to disable protection functions temporarily provides study engineers with valuable system diagnostic information.
- J. *Include documentation and a sample implementation test case.* Test case models should be configured according to the site-specific real equipment configuration up to the Point of Interconnection. This would include (for example): aggregated generator model, aggregated generator transformer, equivalent collector branch, main step up transformers, gen tie line, and any other static or dynamic reactive resources. Test case should use a single machine infinite bus representation of the system, configured with an appropriate representative SCR, such as 2.5. Access to technical support engineers is desirable.
- K. *Have an identification mechanism for configuration.* The model documentation should provide a clear way to identify the specific settings and equipment configuration which will be used in any

---

<sup>3</sup> Care should be taken to ensure that any user-settable options are not changed in a way that is not implementable in the real hardware, and that any selectable options are actually available at the specific site being considered. Discussion is recommended with the manufacturer prior to any changes being made in model configuration.

- study, such that during commissioning the settings used in the studies can be checked. This may be control revision codes, settings files, or a combination of these and other identification measures.
- L. *Accept external reference variables.* This includes real and reactive power ordered values for Q control modes, or voltage reference values for voltage control modes. Model should accept these reference variables for initialization, and be capable of changing these reference variables mid-simulation, ie. dynamic signal references.
  - M. *Be capable of initializing itself.* Once provided with initial condition variables, the model must initialize and ramp to the ordered output without external input from simulation engineers. Any slower control functions which are included (such as switched shunt controllers or power plant controllers) should also accept initial condition variables if required.
  - N. *Have the ability to scale plant capacity.* The active power capacity of the model should be scalable in some way, either internally or through an external scaling transformer<sup>4</sup>. This is distinct from a dispatchable power order, and is used for modeling different capacities of plant or breaking a lumped equivalent plant into smaller composite models.
  - O. *Have the ability to dispatch its output to values less than nameplate.* This is distinct from scaling a plant from one unit to more than one, and is used for testing plant behaviour at various operating points.
  - P. *Initialize quickly.* Model must reach its ordered initial conditions as quickly as possible (for example <5 seconds) to user supplied terminal conditions.

#### Study Efficiency Features

In addition, the following elements are required to improve study efficiency, model compatibility, and enable other studies which include the model to be run as efficiently as possible. If these features are not supported, additional discussion is required<sup>5</sup>:

- Q. Model should be compatible with Intel Fortran compiler version 12 and higher.
- R. Model should be compatible with PSCAD version 4.5.3 and higher.
- S. Model supports multiple instances of its own definition in the same simulation case.
- T. Model supports the PSCAD “timed snapshot” feature accessible through project settings.
- U. Model supports the PSCAD “multiple run” feature.
- V. Model does not use or rely upon global variables in the PSCAD environment.
- W. Model should not utilize multiple layers in the PSCAD environment, including ‘disabled’ layers.

---

<sup>4</sup> A free publicly available scaling transformer suitable for this purpose is available in the E-Tran library.

<sup>5</sup> Electrenix has parallelization tools available (E-Tran Plus for PSCAD) which can circumvent compatibility concerns in some cases.

## Attachment #1: PSCAD Model Test Checklist

*Electranix makes no representations or warranties of any kind concerning this document, whether express, implied, statutory, or other. This includes, without limitation, warranties of title, merchantability, fitness for a particular purpose, non-infringement, absence of latent or other defects, accuracy, or the presence or absence of errors, whether or not known or discoverable. Electranix will not be held liable for any direct, special, indirect, incidental, consequential, punitive, exemplary, or other losses, costs, expenses, or damages arising out of use of this document or any material herein, even if Electranix has been advised of the possibility of such losses, costs, expenses, or damages.*

Copyright PSCAD Model Requirements Supplier Checklist © 2020 by Electranix Corporation. Please contact [info@electranix.com](mailto:info@electranix.com) for information regarding use or modification of this document.



## Purpose

This document is a test checklist meant to accompany “PSCAD Model Requirements Rev. 9” provided above and “Attachment #2: PSCAD Model Requirements Supplier Checklist”. The procedures provided in this document are intended to provide an indication of the core model accuracy, performance, and usability features specified in the model requirements. These procedures cannot ultimately prove that the model is compliant with all requirements, as black box models usually hide the details of the equipment controls and protection. It is recommended that the equipment manufacturer supply additional confirmation that the model meets each individual requirement. The requirements in this document do not necessarily represent interconnection criteria for specific individual systems, and may be supplemented or adjusted based on interconnection region.

The tests outlined here are considered “basic”, and may be supplemented by more rigorous testing, including various fault types, depths, and durations, as well as more extensive protection testing and benchmarking against phasor models. This document is not intended to be a guide for thorough benchmarking between PSCAD, PSS/E, and actual equipment, and is subject to revision as the state of the art in EMT modeling evolves.

<i>Model test Summary</i>	
Model Test date:	
Project Name:	
Manufacturer:	
Equipment type: (eg. PV or Wind)	
Equipment version:	
Documentation file:	
Model Files supplied:	

## Verification Procedure and Checklist

		Pass/Fail	Comments
<i>Vendor and site specific model verification</i>			
1a	The Vendor's name and the specific version of the model should be clearly observable in the .psc model file.		
1b	Documentation and supporting model filenames should not conflict with model version shown in the .psc model file.		
1c	Model is supplied with a test circuit which is configured for the site specific application. <sup>6</sup>		
<i>"Real Code" model verification</i>			
2a	Controls are black-boxed, and no PSCAD master library control blocks are visible within control circuits. <sup>7</sup> If the model is not based on "real code", a separate validation report is required showing model comparison against hardware tests. <sup>8</sup>		
<i>Model usability verification</i>			
3a	Model uses a timestep greater than 10 $\mu$ s <sup>9</sup>		
3b	Model allows a variation in simulation timestep		
3c	Model compiles using Intel FORTRAN version 12		
3d	Model initializes in 5 seconds or less with a POI level SCR of 2.5. Real power, reactive power, and RMS voltage should reach steady state by this time.		
3e	Model allows multiple instances of itself to be run together in the same case <sup>10</sup>		
<i>Model electrical configuration verification</i>			
4a	Plant level electrical single line diagram (SLD) is included.		

<sup>6</sup> The test circuit should model all relevant electrical components of the plant and contain a system equivalent. Parameters will be assumed to be site-specific, unless there are obvious indications otherwise, such as an incorrect grid base frequency.

<sup>7</sup> Black-boxing of controls to a high level does not guarantee that real-code is embedded into the model, however the visibility of PSCAD master-library control blocks in the inner control loops (PLL, inner current controllers, etc.) suggest that the model is generic in nature. Model documentation may contain information on use of real-code in the model.

<sup>8</sup> All aspects of the controller operation are required to be validated by utilizing a "hardware in loop" platform or other hardware test systems. Model should not be validated against other software models. Validations should include control responses to various types of faults, changes in power and voltage references, changes in system frequency, testing frequency response in sub and super-synchronous ranges, and testing of protection operation. Tests should also be performed under a variety of system strengths, including very weak systems. Other tests may also be required. The validation report is required along with any model updates that result from the more rigorous validation tests.

<sup>9</sup> Models with timesteps less than 10  $\mu$ s may be acceptable in situations where a small timestep does not significantly increase the runtime of the total simulation

<sup>10</sup> Depending on specific application and whether E-Tran Plus for PSCAD is allowed to be used to overcome the limitation, this requirement may be waived.



4b	Generator step-up transformer(s) included, with impedance between 5 and 10% on generator base, and matches SLD. <sup>11</sup>		
4c	Lumped collector equivalent(s) included, with total charging equal to between 0.5 and 5% of plant rating, and matches SLD. <sup>11</sup>		
4d	Substation transformer(s) included, rated appropriately for plant size, and impedance between 6 and 12% on transformer base, and matches SLD. <sup>11</sup>		
4e	Model can be scaled to represent any number inverters/turbines, either using a scaling transformer or internal scaling.		
4f	All external devices included in the plant (such as STATCOMs) include appropriate models.		
<i>Plant controller verification</i>			
5a	Model includes power plant controller (PPC)		
5b	PPC accepts an external active power setpoint.		
5c	PPC accepts a voltage setpoint.		
5d	PPC has a mechanism to implement a settable voltage droop.		
5e	Overall plant responds to frequency changes by increasing or decreasing its active power as appropriate. This may be accomplished either at an inverter level or via the PPC. <sup>12</sup>		
5f	Model initializes to the setpoints specified in the PPC. If droops or deadbands are utilized, the initial values may differ from the setpoints. <sup>13</sup>		
5g	If external voltage control devices (STATCOM/DVAR, SVC, MSCs) are included in the plant, ensure that the voltage control of these devices is coordinated with the PPC, with no potential for VAR looping or oscillations.		
<i>Basic performance verification<sup>14</sup></i>			
6a	Instantaneous voltage and current waveforms have minimal distortion, and no oscillations are observed.		

<sup>11</sup> Impedance range is for sanity checking only. Impedances outside this range may be allowed.

<sup>12</sup> Non-compliance with this item may not require model revision as frequency response may not be required in PSCAD models by some utilities. In this case, a description of the under/over frequency response capabilities of the actual equipment should be provided by the manufacturer.

<sup>13</sup> If voltage control with droop is implemented, it is preferred that the PPC model requests an initial Q value to match the voltage setpoint. If no initial Q is requested, the voltage setpoint can be biased by the initial Q before it is sent to the PPC. If a non-zero deadband is included in the voltage controller, the deadband can also be considered in the voltage setpoint sent to the PPC.

<sup>14</sup> Performance testing is recommended with a POI level SCR of 2.5 as this is a representative system condition seen during weak system studies. Testing may be performed at higher SCRs if the stable operating SCR of a model is known to be above 2.5.



6b	Model is able to ride-through and recover from a temporary (no line outage or drop in SCR), 6-cycle, zero-impedance, three-phase fault at the high side of the station transformer, with a POI level SCR of 2.5.		
6c	Model responds to a step change in PPC voltage setpoint, reaching 90% of the new value between 1 and 10 seconds in a test system with POI level SCR of 2.5. (Various systems may have specific speed requirements, which should be met)		
6d	Model responds to a step change in PPC active power setpoint, reaching 90% of the new value between 1 and 10 seconds in a test system with POI level SCR of 2.5. <sup>15</sup>		
<i>Basic protection verification<sup>16</sup></i>			
7a	Protection settings are implemented. These could be available as inputs in the model, or hard-coded in the black-boxed controls. <sup>17</sup>		
7b	Option to disable protection models is present. <sup>18</sup>		
7c	Model trips or blocks when terminal voltage rises above 1.3 pu for 1.5 second. <sup>19</sup>		
7d	Model trips or blocks when terminal voltage falls below 0.2 pu for 1.5 second. <sup>19</sup>		
7e	Model clearly displays trip / diagnostic signals indicating the status of all pertinent protection elements		
<i>Documentation</i>			
8a	Model documentation states compliance with "PSCAD Model Requirements Rev. 9 Rev. 9" <sup>20</sup> , or is supplied with a completed PSCAD Model Requirements Supplier Checklist.		
8b	Model documentation includes instructions for setup and running of the model, including the recommended range of simulation timesteps. Documentation should give a clear description of trip / operation code signals produced by model.		

<sup>15</sup> Different response time criteria may apply depending on specific interconnection region.

<sup>16</sup> There are many protection functions which should be modelled, per footnote 1, and these basic tests will not be proof that these are modelled.

<sup>17</sup> If settings are not visible in model or documentation, verification that protection settings are implemented in the PSCAD model should be received from the manufacturer.

<sup>18</sup> Non-compliance may not require model revision as many studies do not require testing with protection settings disabled.

<sup>19</sup> Non-compliance with this item should result in verification of protection settings implementation from the manufacturer, as some models may have capabilities beyond what is listed here.

<sup>20</sup> Non-compliance may be waived in systems which do not require compliance with the model requirements document.

## Attachment #2: PSCAD Model Requirements Supplier Checklist

*Electranix makes no representations or warranties of any kind concerning this document, whether express, implied, statutory, or other. This includes, without limitation, warranties of title, merchantability, fitness for a particular purpose, non-infringement, absence of latent or other defects, accuracy, or the presence or absence of errors, whether or not known or discoverable. Electranix will not be held liable for any direct, special, indirect, incidental, consequential, punitive, exemplary, or other losses, costs, expenses, or damages arising out of use of this document or any material herein, even if Electranix has been advised of the possibility of such losses, costs, expenses, or damages.*

Copyright PSCAD Model Requirements Supplier Checklist © 2020 by Electranix Corporation. Please contact [info@electranix.com](mailto:info@electranix.com) for information regarding use or modification of this document.



This work is licensed under the Creative Commons Attribution 4.0 International License. To view a copy of this license, visit <http://creativecommons.org/licenses/by/4.0/> or send a letter to Creative Commons, PO Box 1866, Mountain View, CA 94042, USA.

## Purpose

This document is a model requirements checklist which should be completed by the supplier of the model and submitted alongside each PSCAD model. This document accompanies the “PSCAD Model Requirements Rev. 9” document above (PMR), which should be used for further reference to describe the requirements associated with each point. Generic testing of the model may be done using “Attachment #1: PSCAD Model Test Checklist”, which may be used as a reference.

Model supplier must review every item in the checklist and indicate compliance for each item. If the supplied model does not meet any of the requirements an explanation of the deficiency should be provided in the comments column.

<i>Model Submission Summary (to be completed by model supplier)</i>	
Submission date:	
Project Name:	
Primary contact information for model related questions:	
Secondary contact information for model related questions:	
Manufacturer:	
Equipment type: (eg. PV or Wind)	
Equipment version:	
Documentation file(s):	
Model Files supplied:	

Model Requirements Checklist				Model Complies? (Yes/No)	Comments
<b>1 Model Accuracy Features</b>					
1.1	Power electronic controls are modelled by interfacing with actual firmware code from the inverter (“real code” model), or includes detailed validation report.	A, B			
1.2	Operating modes which require system specific adjustment are accessible.	B			
1.3	Plant level controller is included. <sup>21</sup>	B			
1.4	Model is capable of controlling frequency <sup>22</sup>	B			
1.5	Includes pertinent electrical and mechanical features, such as gearboxes, pitch controllers, or other features which impact the plant performance in the simulation period. <sup>23</sup>	C			
1.6	All protections which could impact ride-through performance are modelled in detail.	D			
1.7	Model is configured for the specific site being evaluated, as far as they are known.	E			
<b>2 Model and Project Documentation</b>					
2.1	Model includes documentation.	J			
2.2	Documentation includes instruction for setup and running the model.	J			

<sup>21</sup> If the plant is part of a multi-plant control scheme, a description of the overall scheme should be provided, and corresponding PPC models should be configured to control multiple plants accordingly.

<sup>22</sup> Frequency control model requirements may vary by region. Example response time may be less than 10 seconds.

<sup>23</sup> Simulation period may vary depending on the model use, but 10 seconds of simulation following an event such as a fault is a typical period.

**Recommended PSCAD Model Requirements Rev. 9**  
**May 8, 2020**

2.3	Model is supplied with a sample test case including site specific plant representation.	J	
2.4	Plant single line diagram is provided, and aligns with model	J	
2.5	Model documentation provides a clear way to identify site-specific settings and equipment configuration.	K	
<b>3 Model Usability Features</b>			
3.01	Control or hardware options are accessible to the user as applicable.	F	
3.02	Diagnostic flags are visible to the user.	F	
3.03	Model uses a timestep greater than 10 $\mu$ s.	G	
3.04	Model allows a range of simulation timesteps (ie. not restricted to a single timestep).	H	
3.05	Protection model may be disabled for troubleshooting	I	
3.06	Model accepts external reference variables for active and reactive power and voltage setpoint, and these may be changed dynamically during the simulation.	L	
3.07	Model is capable of initializing itself.	M	
3.08	Active power capacity is scalable.	N	
3.09	Active power is dispatchable.	O	
3.10	Model reaches setpoint P, Q, and V in 5 seconds or less	P	
3.11	Model compatible with Intel FORTRAN version 12 and higher.	Q	
3.12	Model compiles using PSCAD version 4.5.3 or higher.	R	
3.13	Model supports multiple instances of its own definition in a single PSCAD case.	S	
3.14	Model supports PSCAD "snapshot" feature.	T	

This work is licensed under the Creative Commons Attribution 4.0 International License. To view a copy of this license, visit <http://creativecommons.org/licenses/by/4.0/> or send a letter to Creative Commons, PO Box 1866, Mountain View, CA 94042, USA.

**Recommended PSCAD Model Requirements Rev. 9  
May 8, 2020**



3.15	Model supports the PSCAD “multiple run” feature.	U	
3.16	Model does not use PSCAD global variables.	V	
3.17	Model does not use PSCAD layer functionality	W	

---

This work is licensed under the Creative Commons Attribution 4.0 International License. To view a copy of this license, visit <http://creativecommons.org/licenses/by/4.0/> or send a letter to Creative Commons, PO Box 1866, Mountain View, CA 94042, USA.



Transmission and Distribution Planning Division - Interconnection Services Department

Simulation Tests

CBRE RFP Interconnection Requirement Study-System Impact Study

Date: July 7, 2020

---

## 1. Introduction

This document describes the simulation tests that Hawaiian Electric IRS study consultants will perform to check the models submitted for CBRE IRS. Results of these tests, combined with other checks on project input data and model parameters, will determine if the models are acceptable for the IRS studies. The models to be tested are PSS E user-written model, PSCAD model and ASPEN short-circuit model for each project.

It is recommended that the model submitters should also perform these tests to self-check on your models, so that your models will become acceptable for the IRS study in a timely manner.

## 2. Separate Models Required for Grid Following Mode and Grid Forming Mode

For the CBRE IRS, modeling of inverter Grid Forming capabilities may be required. For each project, separate models should be submitted: one with the project in Grid Forming (GFM) mode (if applicable), and the other with the project in Grid Following (GFL) mode. This requirement applies to all models mentioned above.

## 3. General Requirements

All submitted models should be accompanied by proper documentation.

There should be a reasonable match between the PSS E user-written model and the PSCAD model responses for the simulation tests performed for both models.

## 4. List of Simulation Tests

### 4.1 GFL Mode Simulation Tests

#### 4.1.1 Tests to be performed for PSS E models

- a. Flat run in a two-machine system (one machine is a synchronous machine, e.g., GENCLS model, and the other machine is a project's model.)
  - b. Ringdown (3ph-ground fault simulation test) in a two-machine system.
-

***GFL-Tests to be performed for PSS E models - continued***

- c. Voltage ride-through and response in a two-machine system.
- d. Frequency ride-through and response in a two-machine system.
- e. Weak grid operation in a two-machine system  
Gradually increase/decrease MVA of the synchronous machine within a range and check if the project's model is able to work with the studied MVA range.
- f. Simulation in a relevant HECO island system model for a couple of selected faults  
The purpose here is to identify potential issues with a project's PSS E model ahead of dynamic stability analysis to limit study delays due to model issues.

Note: also refer to "Siemens PTI Model Review process\_200317.pdf".

***4.1.2 Tests to be performed for PSCAD models only (includes model adequacy and documentation checks)***

- g. Tests and checks outlined in "PSCAD Requirements Rev 9 May 2020.pdf", inclusive of ringdown, voltage and frequency ride-through tests.





## 4.2 GFM Mode Simulation Tests

### 4.2.1 Tests to be performed for both PSS E and PSCAD models

Test notes:

- Applicable for projects which include grid-forming BESS only
- Assumption is that BESS has available energy and is dispatched suitably for the tests (i.e. Not at current limit)

#### a. Able to black start and operate in island mode

Test sequence: energize main power transformer from project side, then connect project to a load, then apply a bus fault at the POI, then remove the fault. Results: voltage and frequency should be stable and settle back to close to their nominal values after the disturbances.

#### b. Loss of the last synchronous machine

Test system will be a three-machine system including: a synchronous machine modeled by GENROU with a simple excitation system model (e.g., SCR<sub>X</sub>) and a simple governor model (e.g., TGOV1), a load with both real and reactive components, and duplicates of a project's model. Duplicates of a project's model are utilized here to check if the project is able to share real and reactive power properly with other generators. Test event: trip the synchronous generator. Results: voltage and frequency should be stable and settle back to close to their nominal values after the disturbance.

#### c. Weak grid operation

Test system is the two-machine system. Gradually increase/decrease MVA of the synchronous machine within a range and check if the project's model is able to work with the studied MVA range.

#### d. Able to operate in harmony with other converter resources and synchronous machines

Test system is the three-machine system including: a synchronous machine modeled by GENROU with a simple excitation system model and a simple governor model, a load with both real and reactive components, and duplicates of a project's model. Simulation tests to be performed may include load step up/down, ringdown, voltage ride through and frequency ride-through tests. Results: voltage and frequency should be stable and settle back to close to their nominal values after the disturbances.



### ***GFM Mode Simulation Tests – Tests to be performed for both PSS E and PSCAD models - continued***

Particularly related to frequency control characteristics, we will test for configurable frequency droop control and configurable deadband characteristics. The frequency deadband should be settable in the range from +/- 0.01 Hz to +/- 1.0 Hz and the frequency droop shall be settable in the range of 0.1% to 10% with a typical value of 4%. A sample characteristic of frequency droop control with deadband is shown in Figure 1.

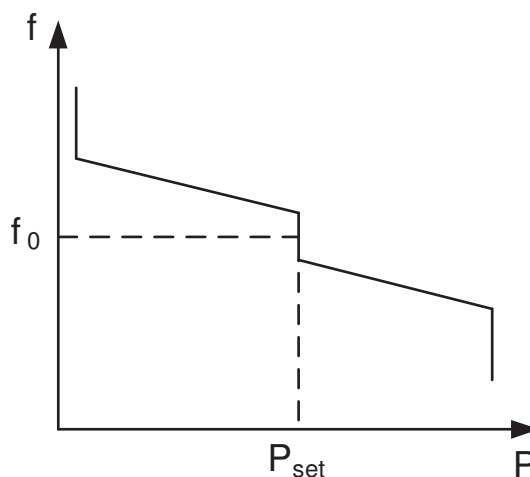

**Figure 1 – Frequency Droop Control Characteristic with Deadband**

- e. Switching between GFL mode and GFM mode

Test system is the two-machine system. Test sequence: energize main power transformer from project side, then connect project to a load. At this point, the project will be operating in island mode, performing frequency control. Then switch in the synchronous generator; the project will be operating in power/frequency droop control mode. Results: voltage and frequency should be stable and settle back to close to their nominal values after the disturbances.

#### **4.2.2 Tests to be performed for PSS E models only**

- a. Reduction in frequency deviation in GFM mode

Test system will be a relevant HECO island system model. Test event is loss of a large generator. Project model will be in GFL mode and GFM mode. Result: less degree of frequency deviation is expected when project is in GFM mode than when the project is in GFL mode.



### 4.3 ASPEN Model Check

A review of the ASPEN models will be performed. As mentioned above, two models are expected for each project: one model for GFL mode, and the other for GFM mode. Documentation associated with the models should be provided. The model review will check if the components of a project are modeled properly, such as transformers, equivalent collector system, equivalent generator, etc., and that the model data are consistent to the PSS E and PSCAD model data. A fault simulation test will also be performed in a two-machine system. Total current at the fault location and contribution from each machine will be reviewed and documented.



Siemens Industry, Inc.

Siemens Power Technologies International

4000 East Third Avenue - Suite 400

Foster City, CA 94404 USA

Tel: +1 (650) 772-2289

www.siemens.com/power-technologies

**Date:** March 17, 2020**From:** Osazuwa Oriakhi, Wenchun Zhu and Kavita Shenoi, Siemens PTI**RE: HECO IRS Model Review Process**

Message from Interconnection Services: This document shows you an example of the model data review and tests that a study consultant performs on your model data submittal under the Interconnection Requirement Study, System Impact Study (IRS SIS Agreement. The Test Package that you are receiving is repeated for the IRS. By performing these tests as a Do-it-Yourself (DIY) , model data submittals when we receive them for the IRS SIS are understood to be accurate and have usability and efficiency features to integrate the facility model data with the Company's system model data and commence the IRS SIS analyses in a prompt and efficient manner.

Siemens PTI performs the following data checks and tests as a part of our Model review process.

#### A. Steady State Data Review

Siemens PTI will review the ratings and impedances of all equipment in the ASPEN, PSS<sup>®</sup>E and PSCAD models and check for discrepancies. Table 1 below shows the comparison of power flow data for all equipment in the PSS<sup>®</sup>E and PSCAD models.

**Table 1. Steady State Data Review**

Equipment	Comments
Gen-Tie line	PSS <sup>®</sup> E, PSCAD and ASPEN models should match
Main Power Transformer Impedance	PSS <sup>®</sup> E, PSCAD and ASPEN models should match
Main Power Transformer Configuration	PSCAD and ASPEN models should match
PV Collector System Data	PSS <sup>®</sup> E, PSCAD and ASPEN models should match
BESS Collector System Data	PSS <sup>®</sup> E, PSCAD and ASPEN models should match
Inverter Pad Mount Transformer Impedance	PSS <sup>®</sup> E, PSCAD and ASPEN models should match
Inverter Pad Mount Transformer Configuration	PSCAD and ASPEN models should match
Inverter Power Flow Data	PSS <sup>®</sup> E and PSCAD models should match
Voltage Control Point	PSS <sup>®</sup> E and PSCAD models should match

*This document was prepared by Siemens Industry, Inc., Siemens Power Technologies International (Siemens PTI), solely for the benefit of the recipient named in this memorandum. Siemens PTI nor any party acting on its behalf (a) makes any warranty, expressed or implied, with respect to the use of any information or methods disclosed in this document; or (b) assumes any liability with respect to the use of any information or methods disclosed in this document.*

*Any party other than the named recipient of this memorandum, by their acceptance or use of this document, releases Siemens PTI from any liability for direct, indirect, consequential or special loss or damage whether arising in contract, warranty, express or implied, tort or otherwise, and irrespective of fault, negligence, and strict liability.*

**B. Dynamic Model Data Review**

There are three types of models which show the transient/dynamic behavior of the generation facility:

1. A PSS®E user-written dynamic model which is a detailed model of the specific inverters and controls provided by the manufacturer.
2. A PSS®E generic model which utilizes PSS®E library models to specify the dynamic behavior of the facility.
3. A PSCAD model which is a detailed transient model of the inverters and controls

Siemens PTI will compare the various dynamic model parameters across the three models and note any discrepancies in the data fields shown in Table 2.

**Table 2. Comparison of Dynamic Model Parameters**

Parameters	Comments
Power Plant Controller (PPC)	Review number of PPCs
Control Flags	PSS®E and PSCAD control flags should match.
Control Bus/Point of Measurement	Control buses should match in PSS®E and PSCAD models.
Frequency Control Dead Band	The frequency thresholds for primary and secondary control should match in the PSCAD and PSS®E models.
Initial State of Charge (SOC)	Make sure the initial state of charge is set up correctly to prevent initialization issues.
Voltage and Frequency Ride Through Settings	The voltage and frequency ride through settings should match in the PSS®E user-written, PSS®E generic and PSCAD models.
P/Q priority data	The P/Q priority flags should match in the PSS®E user-written, PSS®E generic and PSCAD models

**C. Model tests**

Siemens PTI will perform the following tests to check the active power, reactive power, voltage and frequency responses of the generation facility and review if the three models (PSS®E user-written, PSS®E generic and PSCAD models) show consistent responses.

1. **Flat Run Test:** This is a no-disturbance simulation to check a model's initialization. This test is applicable to all three types of models.
2. **Ring Down Test:** In this simulation, a fault is placed at the facility's POI for a duration of 6-cycles. The fault is subsequently cleared, and the post-disturbance response of the facility is observed. This test is applicable to all three types of models.
3. **High and Low Frequency Response Test:** In these simulations, the system frequency is varied to test the facility's responses to grid's frequency excursions. In the PSS®E tests, high and low frequency excursions are simulated to mimic the frequency ride through thresholds specified in the PPA and the response of the facility is observed. Both the frequency ride-through capability of the facility and its active power response to frequency excursions are tested in the PSS®E simulations.

In the PSCAD simulations, the focus is on testing the facility's active power responses to frequency excursions, and not on testing the frequency ride-through capability. However, it should be noted that the duration of the frequency excursions in the PSCAD tests are well-

within the no-trip zones according to the PPA, and so the facility is not expected to trip during these simulations. Table 3 and Table 4 show the frequency excursions that were simulated in the PSCAD tests.

**Table 3 Frequency Excursions for PSCAD High Frequency Response Test**

Frequency level (Hz)	Duration (secs)
60.1	2.0
63.0	2.0

**Table 4 Frequency Excursions for PSCAD Low Frequency Response Test**

Frequency level (Hz)	Duration (secs)
59.9	2.0
56.0	2.0

4. **High and Low Voltage Ride-through and Response Tests:** In these simulations, the POI voltage is varied to test the facility's ride-through capabilities and responses to POI voltage excursions. In the PSS<sup>®</sup>E simulations, two sets of tests are performed: one for testing the ride-through capabilities and the other for testing the responses to voltage excursions. These two sets of tests are similar, except that the grid equivalent representation is different. For the ride-through tests, the grid equivalent is represented by a generator with a very large MVA, which connects to the POI bus directly. For the voltage excursion response tests, the grid equivalent is represented by a 500 MVA generator which connects to the POI through a branch with a reactance of 0.1 p.u.

In the PSCAD simulations, the focus is on testing the facility's reactive power responses to POI voltage excursions, and not on testing the voltage ride-through capability. However, it should be noted that the duration of the voltage excursions in the PSCAD tests are well within the no-trip zones according to the PPA, and so the facility is not expected to trip during these simulations.

Table 5 shows the voltage excursions that will be simulated in the PSCAD tests.

**Table 5 POI Voltage Excursions for PSCAD Voltage Response Test**

POI Voltage level (pu)	Duration (secs)
1.20	0.8
1.10	2.0
0.88	2.0
0.70	2.0

Each of the above discussed tests were performed for the following three generation dispatches:

- **PV output only:** In this dispatch, the PV unit is at maximum output and the BESS unit is online at 0 MW.
- **BESS output only:** In this dispatch, the BESS unit is discharging at maximum output and the PV unit is online at 0 MW.

- **PV charging BESS:** In this dispatch, the PV unit is at its maximum output and is charging the BESS at its minimum level.

#### **D. Expected Model Performance**

1. Matching steady-state model parameters between the PSS®E user-written, generic models and the PSCAD model.
2. Matching control options between the three types of models.
3. Matching voltage and frequency ride-through parameters between the three types of models. The settings should meet the ride-through requirements specified in the PPA.
4. Flat run results do not show any movement for any of the three models.
5. Ring-down simulation results show stable and proper responses, and the responses from the three models should show reasonable matches.
6. Ride-through simulation results should show stable and proper responses, and the responses should show reasonable matches. The ride through performance should meet the PPA requirements.

#### **E. Model Review Reporting Requirements**

1. Simulation tests should be performed using the python scripts provided by Siemens PTI, and should be readily reproducible.
2. Discuss model review results.
3. Include simulation plots for the simulation tests discussed above.
4. Related to high and low frequency ride through tests, document frequency response droops shown in the simulations.

## PSCAD Model Requirements Rev. 9

**Date:** May 8, 2020  
**Prepared By:** Andrew L. Isaacs  
Lukas Unruh  
Garth Irwin

**This document includes the following attachments:**

**Attachment #1: PSCAD Model Test Checklist**

**Attachment #2: PSCAD Model Requirements Supplier Checklist**

*Electranix makes no representations or warranties of any kind concerning this document, whether express, implied, statutory, or other. This includes, without limitation, warranties of title, merchantability, fitness for a particular purpose, non-infringement, absence of latent or other defects, accuracy, or the presence or absence of errors, whether or not known or discoverable. Electranix will not be held liable for any direct, special, indirect, incidental, consequential, punitive, exemplary, or other losses, costs, expenses, or damages arising out of use of this document or any material herein, even if Electranix has been advised of the possibility of such losses, costs, expenses, or damages.*

Copyright PSCAD Model Requirements Supplier Checklist © 2020 by Electranix Corporation. Please contact [info@electranix.com](mailto:info@electranix.com) for information regarding use or modification of this document.

12-75 Scurfield Blvd.  
Winnipeg, MB, Canada, R3Y 1P6  
[www.electranix.com](http://www.electranix.com)

**ELECTRANIX**  
SPECIALISTS IN POWER SYSTEM STUDIES

This work is licensed under the Creative Commons Attribution 4.0 International License. To view a copy of this license, visit <http://creativecommons.org/licenses/by/4.0/> or send a letter to Creative Commons, PO Box 1866, Mountain View, CA 94042, USA.



### *Introduction*

Specific model requirements for a PSCAD study depend on the type of study being done. A study with a scope covering weak system interconnections, ride-through evaluation, short term<sup>1</sup> event response, and fast control interaction with nearby devices (for example) would require a model which has the following characteristics. Some specialty studies may require other features. Refer to “Attachment #1: PSCAD Model Test Checklist” and “Attachment #2: PSCAD Model Requirements Supplier Checklist”, appended to this document, for additional information on how these requirements may be applied.

### *Model Accuracy Features*

For the model to be sufficiently accurate, it must:

- A. *Represent the full detailed inner control loops of the power electronics.* The model cannot use the same approximations classically used in transient stability modeling, and should fully represent all fast inner controls, as implemented in the real equipment. Models which embed the actual hardware code into a PSCAD component are currently wide-spread, and this is the recommended type of model.<sup>2</sup>
- B. *Represent all control features pertinent to the type of study being done.* Examples include external voltage controllers, plant level controllers, customized PLLs, ride-through controllers, SSCI damping controllers and others. As in point A, actual hardware code is recommended to be used for most control and protection features. Operating modes that require system specific adjustment should be user accessible. Plant level voltage control should be represented along with adjustable droop characteristics. If multiple plants are controlled by a common controller, this functionality should be included.
- C. *Represent all pertinent electrical and mechanical configurations.* This includes any filters and specialized transformers. There may be other mechanical features such as gearboxes, pitch controllers, or others which should be modelled if they impact electrical performance within the timeframe of the study. Any control or dynamic features of the actual equipment which may influence behaviour in the simulation period which are not represented or which are approximated should be clearly identified.

---

<sup>1</sup> Example analysis periods could be 2 to 10 seconds from fault inception. Some studies could require longer periods.

<sup>2</sup> The model must be a full IGBT representation (preferred), or may use a voltage source representation that approximates the IGBT switching but maintains full detail in the controls. A three phase sinusoidal source representation is not acceptable. Models manually translated block-by-block from MATLAB or control block diagrams may be unacceptable because the method used to model the electrical network and interface to the controls may not be accurate, or portions of the controls such as PLL circuits or protection circuits may be approximated or omitted. Note that firmware code may be directly used to create an extremely accurate PSCAD model of the controls. The controller source code may be compiled into DLLs or binaries if the source code is unavailable due to confidentiality restrictions.

It is not recommended to assemble the model using standard blocks available in the PSCAD master library, as approximations are usually introduced, and specific implementation details for important control blocks may be lost. In addition, there is a significant risk that errors will be introduced in the process of manually assembling the model. For this type of manually assembled model, (not using a direct “real code” embedding process), extra care is required, and validation is required.

- D. *Have all pertinent protections modeled in detail for both balanced and unbalanced fault conditions.* Typically this includes various OV and UV protections (individual phase and RMS), frequency protections, DC bus voltage protections, converter overcurrent protections, and often other inverter specific protections. As in point A, actual hardware code is recommended to be used for these protection features.
- E. *Be configured to match expected site-specific equipment settings.* Any user-tunable parameters or options should be set in the model to match the equipment at the specific site being evaluated, as far as they are known. Default parameters may not be appropriate.

#### *Model Usability Features*

In order to allow study engineers to perform system analysis using the model, the PSCAD model must:

- F. *Have control or hardware options which are pertinent to the study accessible to the user.* Examples of this could include protection thresholds, real power recovery ramp rates, or SSCI damping controllers.<sup>3</sup> Diagnostic flags (eg. flags to show control mode changes or which protection has been activated) should be visible to aid in analysis.
- G. *Be accurate when running at a simulation time step of 10  $\mu$ s or higher.* Often, requiring a smaller time step means that the control implementation has not used the interpolation features of PSCAD, or is using inappropriate interfacing between the model and the larger network. Lack of interpolation support introduces inaccuracies into the model at larger simulation time-steps. In cases where the IGBT switching frequency is so high that even interpolation does not allow accurate switching representation at 10  $\mu$ s (eg. 40 kHz), an average source approximation of the inverter switching may be used to allow a larger simulation time step<sup>2</sup>.
- H. *Operate at a range of simulation time steps.* The model should not be restricted to operating at a single time step, but should be able to operate within a range (eg. 10  $\mu$ s – 20  $\mu$ s)
- I. *Have the ability to disable protection models.* Many studies result in inadvertent tripping of converter equipment, and the ability to disable protection functions temporarily provides study engineers with valuable system diagnostic information.
- J. *Include documentation and a sample implementation test case.* Test case models should be configured according to the site-specific real equipment configuration up to the Point of Interconnection. This would include (for example): aggregated generator model, aggregated generator transformer, equivalent collector branch, main step up transformers, gen tie line, and any other static or dynamic reactive resources. Test case should use a single machine infinite bus representation of the system, configured with an appropriate representative SCR, such as 2.5. Access to technical support engineers is desirable.
- K. *Have an identification mechanism for configuration.* The model documentation should provide a clear way to identify the specific settings and equipment configuration which will be used in any

---

<sup>3</sup> Care should be taken to ensure that any user-settable options are not changed in a way that is not implementable in the real hardware, and that any selectable options are actually available at the specific site being considered. Discussion is recommended with the manufacturer prior to any changes being made in model configuration.

- study, such that during commissioning the settings used in the studies can be checked. This may be control revision codes, settings files, or a combination of these and other identification measures.
- L. *Accept external reference variables.* This includes real and reactive power ordered values for Q control modes, or voltage reference values for voltage control modes. Model should accept these reference variables for initialization, and be capable of changing these reference variables mid-simulation, ie. dynamic signal references.
  - M. *Be capable of initializing itself.* Once provided with initial condition variables, the model must initialize and ramp to the ordered output without external input from simulation engineers. Any slower control functions which are included (such as switched shunt controllers or power plant controllers) should also accept initial condition variables if required.
  - N. *Have the ability to scale plant capacity.* The active power capacity of the model should be scalable in some way, either internally or through an external scaling transformer<sup>4</sup>. This is distinct from a dispatchable power order, and is used for modeling different capacities of plant or breaking a lumped equivalent plant into smaller composite models.
  - O. *Have the ability to dispatch its output to values less than nameplate.* This is distinct from scaling a plant from one unit to more than one, and is used for testing plant behaviour at various operating points.
  - P. *Initialize quickly.* Model must reach its ordered initial conditions as quickly as possible (for example <5 seconds) to user supplied terminal conditions.

#### Study Efficiency Features

In addition, the following elements are required to improve study efficiency, model compatibility, and enable other studies which include the model to be run as efficiently as possible. If these features are not supported, additional discussion is required<sup>5</sup>:

- Q. Model should be compatible with Intel Fortran compiler version 12 and higher.
- R. Model should be compatible with PSCAD version 4.5.3 and higher.
- S. Model supports multiple instances of its own definition in the same simulation case.
- T. Model supports the PSCAD “timed snapshot” feature accessible through project settings.
- U. Model supports the PSCAD “multiple run” feature.
- V. Model does not use or rely upon global variables in the PSCAD environment.
- W. Model should not utilize multiple layers in the PSCAD environment, including ‘disabled’ layers.

---

<sup>4</sup> A free publicly available scaling transformer suitable for this purpose is available in the E-Tran library.

<sup>5</sup> Electrenix has parallelization tools available (E-Tran Plus for PSCAD) which can circumvent compatibility concerns in some cases.

## Attachment #1: PSCAD Model Test Checklist

*Electranix makes no representations or warranties of any kind concerning this document, whether express, implied, statutory, or other. This includes, without limitation, warranties of title, merchantability, fitness for a particular purpose, non-infringement, absence of latent or other defects, accuracy, or the presence or absence of errors, whether or not known or discoverable. Electranix will not be held liable for any direct, special, indirect, incidental, consequential, punitive, exemplary, or other losses, costs, expenses, or damages arising out of use of this document or any material herein, even if Electranix has been advised of the possibility of such losses, costs, expenses, or damages.*

Copyright PSCAD Model Requirements Supplier Checklist © 2020 by Electranix Corporation. Please contact [info@electranix.com](mailto:info@electranix.com) for information regarding use or modification of this document.



## Purpose

This document is a test checklist meant to accompany “PSCAD Model Requirements Rev. 9” provided above and “Attachment #2: PSCAD Model Requirements Supplier Checklist”. The procedures provided in this document are intended to provide an indication of the core model accuracy, performance, and usability features specified in the model requirements. These procedures cannot ultimately prove that the model is compliant with all requirements, as black box models usually hide the details of the equipment controls and protection. It is recommended that the equipment manufacturer supply additional confirmation that the model meets each individual requirement. The requirements in this document do not necessarily represent interconnection criteria for specific individual systems, and may be supplemented or adjusted based on interconnection region.

The tests outlined here are considered “basic”, and may be supplemented by more rigorous testing, including various fault types, depths, and durations, as well as more extensive protection testing and benchmarking against phasor models. This document is not intended to be a guide for thorough benchmarking between PSCAD, PSS/E, and actual equipment, and is subject to revision as the state of the art in EMT modeling evolves.

<i>Model test Summary</i>	
Model Test date:	
Project Name:	
Manufacturer:	
Equipment type: (eg. PV or Wind)	
Equipment version:	
Documentation file:	
Model Files supplied:	

## Verification Procedure and Checklist

		Pass/Fail	Comments
<i>Vendor and site specific model verification</i>			
1a	The Vendor's name and the specific version of the model should be clearly observable in the .psc model file.		
1b	Documentation and supporting model filenames should not conflict with model version shown in the .psc model file.		
1c	Model is supplied with a test circuit which is configured for the site specific application. <sup>6</sup>		
<i>"Real Code" model verification</i>			
2a	Controls are black-boxed, and no PSCAD master library control blocks are visible within control circuits. <sup>7</sup> If the model is not based on "real code", a separate validation report is required showing model comparison against hardware tests. <sup>8</sup>		
<i>Model usability verification</i>			
3a	Model uses a timestep greater than 10 $\mu$ s <sup>9</sup>		
3b	Model allows a variation in simulation timestep		
3c	Model compiles using Intel FORTRAN version 12		
3d	Model initializes in 5 seconds or less with a POI level SCR of 2.5. Real power, reactive power, and RMS voltage should reach steady state by this time.		
3e	Model allows multiple instances of itself to be run together in the same case <sup>10</sup>		
<i>Model electrical configuration verification</i>			
4a	Plant level electrical single line diagram (SLD) is included.		

<sup>6</sup> The test circuit should model all relevant electrical components of the plant and contain a system equivalent. Parameters will be assumed to be site-specific, unless there are obvious indications otherwise, such as an incorrect grid base frequency.

<sup>7</sup> Black-boxing of controls to a high level does not guarantee that real-code is embedded into the model, however the visibility of PSCAD master-library control blocks in the inner control loops (PLL, inner current controllers, etc.) suggest that the model is generic in nature. Model documentation may contain information on use of real-code in the model.

<sup>8</sup> All aspects of the controller operation are required to be validated by utilizing a "hardware in loop" platform or other hardware test systems. Model should not be validated against other software models. Validations should include control responses to various types of faults, changes in power and voltage references, changes in system frequency, testing frequency response in sub and super-synchronous ranges, and testing of protection operation. Tests should also be performed under a variety of system strengths, including very weak systems. Other tests may also be required. The validation report is required along with any model updates that result from the more rigorous validation tests.

<sup>9</sup> Models with timesteps less than 10  $\mu$ s may be acceptable in situations where a small timestep does not significantly increase the runtime of the total simulation

<sup>10</sup> Depending on specific application and whether E-Tran Plus for PSCAD is allowed to be used to overcome the limitation, this requirement may be waived.

4b	Generator step-up transformer(s) included, with impedance between 5 and 10% on generator base, and matches SLD. <sup>11</sup>		
4c	Lumped collector equivalent(s) included, with total charging equal to between 0.5 and 5% of plant rating, and matches SLD. <sup>11</sup>		
4d	Substation transformer(s) included, rated appropriately for plant size, and impedance between 6 and 12% on transformer base, and matches SLD. <sup>11</sup>		
4e	Model can be scaled to represent any number inverters/turbines, either using a scaling transformer or internal scaling.		
4f	All external devices included in the plant (such as STATCOMs) include appropriate models.		
<i>Plant controller verification</i>			
5a	Model includes power plant controller (PPC)		
5b	PPC accepts an external active power setpoint.		
5c	PPC accepts a voltage setpoint.		
5d	PPC has a mechanism to implement a settable voltage droop.		
5e	Overall plant responds to frequency changes by increasing or decreasing its active power as appropriate. This may be accomplished either at an inverter level or via the PPC. <sup>12</sup>		
5f	Model initializes to the setpoints specified in the PPC. If droops or deadbands are utilized, the initial values may differ from the setpoints. <sup>13</sup>		
5g	If external voltage control devices (STATCOM/DVAR, SVC, MSCs) are included in the plant, ensure that the voltage control of these devices is coordinated with the PPC, with no potential for VAR looping or oscillations.		
<i>Basic performance verification<sup>14</sup></i>			
6a	Instantaneous voltage and current waveforms have minimal distortion, and no oscillations are observed.		

<sup>11</sup> Impedance range is for sanity checking only. Impedances outside this range may be allowed.

<sup>12</sup> Non-compliance with this item may not require model revision as frequency response may not be required in PSCAD models by some utilities. In this case, a description of the under/over frequency response capabilities of the actual equipment should be provided by the manufacturer.

<sup>13</sup> If voltage control with droop is implemented, it is preferred that the PPC model requests an initial Q value to match the voltage setpoint. If no initial Q is requested, the voltage setpoint can be biased by the initial Q before it is sent to the PPC. If a non-zero deadband is included in the voltage controller, the deadband can also be considered in the voltage setpoint sent to the PPC.

<sup>14</sup> Performance testing is recommended with a POI level SCR of 2.5 as this is a representative system condition seen during weak system studies. Testing may be performed at higher SCRs if the stable operating SCR of a model is known to be above 2.5.



6b	Model is able to ride-through and recover from a temporary (no line outage or drop in SCR), 6-cycle, zero-impedance, three-phase fault at the high side of the station transformer, with a POI level SCR of 2.5.		
6c	Model responds to a step change in PPC voltage setpoint, reaching 90% of the new value between 1 and 10 seconds in a test system with POI level SCR of 2.5. (Various systems may have specific speed requirements, which should be met)		
6d	Model responds to a step change in PPC active power setpoint, reaching 90% of the new value between 1 and 10 seconds in a test system with POI level SCR of 2.5. <sup>15</sup>		
<i>Basic protection verification</i> <sup>16</sup>			
7a	Protection settings are implemented. These could be available as inputs in the model, or hard-coded in the black-boxed controls. <sup>17</sup>		
7b	Option to disable protection models is present. <sup>18</sup>		
7c	Model trips or blocks when terminal voltage rises above 1.3 pu for 1.5 second. <sup>19</sup>		
7d	Model trips or blocks when terminal voltage falls below 0.2 pu for 1.5 second. <sup>19</sup>		
7e	Model clearly displays trip / diagnostic signals indicating the status of all pertinent protection elements		
<i>Documentation</i>			
8a	Model documentation states compliance with "PSCAD Model Requirements Rev. 9 Rev. 9" <sup>20</sup> , or is supplied with a completed PSCAD Model Requirements Supplier Checklist.		
8b	Model documentation includes instructions for setup and running of the model, including the recommended range of simulation timesteps. Documentation should give a clear description of trip / operation code signals produced by model.		

<sup>15</sup> Different response time criteria may apply depending on specific interconnection region.

<sup>16</sup> There are many protection functions which should be modelled, per footnote 1, and these basic tests will not be proof that these are modelled.

<sup>17</sup> If settings are not visible in model or documentation, verification that protection settings are implemented in the PSCAD model should be received from the manufacturer.

<sup>18</sup> Non-compliance may not require model revision as many studies do not require testing with protection settings disabled.

<sup>19</sup> Non-compliance with this item should result in verification of protection settings implementation from the manufacturer, as some models may have capabilities beyond what is listed here.

<sup>20</sup> Non-compliance may be waived in systems which do not require compliance with the model requirements document.



## Attachment #2: PSCAD Model Requirements Supplier Checklist

*Electranix makes no representations or warranties of any kind concerning this document, whether express, implied, statutory, or other. This includes, without limitation, warranties of title, merchantability, fitness for a particular purpose, non-infringement, absence of latent or other defects, accuracy, or the presence or absence of errors, whether or not known or discoverable. Electranix will not be held liable for any direct, special, indirect, incidental, consequential, punitive, exemplary, or other losses, costs, expenses, or damages arising out of use of this document or any material herein, even if Electranix has been advised of the possibility of such losses, costs, expenses, or damages.*

Copyright PSCAD Model Requirements Supplier Checklist © 2020 by Electranix Corporation. Please contact [info@electranix.com](mailto:info@electranix.com) for information regarding use or modification of this document.



This work is licensed under the Creative Commons Attribution 4.0 International License. To view a copy of this license, visit <http://creativecommons.org/licenses/by/4.0/> or send a letter to Creative Commons, PO Box 1866, Mountain View, CA 94042, USA.

## Purpose

This document is a model requirements checklist which should be completed by the supplier of the model and submitted alongside each PSCAD model. This document accompanies the “PSCAD Model Requirements Rev. 9” document above (PMR), which should be used for further reference to describe the requirements associated with each point. Generic testing of the model may be done using “Attachment #1: PSCAD Model Test Checklist”, which may be used as a reference.

Model supplier must review every item in the checklist and indicate compliance for each item. If the supplied model does not meet any of the requirements an explanation of the deficiency should be provided in the comments column.

<i>Model Submission Summary (to be completed by model supplier)</i>	
Submission date:	
Project Name:	
Primary contact information for model related questions:	
Secondary contact information for model related questions:	
Manufacturer:	
Equipment type: (eg. PV or Wind)	
Equipment version:	
Documentation file(s):	
Model Files supplied:	

Model Requirements Checklist				Model Complies? (Yes/No)	Comments
<b>1 Model Accuracy Features</b>					
1.1	Power electronic controls are modelled by interfacing with actual firmware code from the inverter (“real code” model), or includes detailed validation report.	A, B			
1.2	Operating modes which require system specific adjustment are accessible.	B			
1.3	Plant level controller is included. <sup>21</sup>	B			
1.4	Model is capable of controlling frequency <sup>22</sup>	B			
1.5	Includes pertinent electrical and mechanical features, such as gearboxes, pitch controllers, or other features which impact the plant performance in the simulation period. <sup>23</sup>	C			
1.6	All protections which could impact ride-through performance are modelled in detail.	D			
1.7	Model is configured for the specific site being evaluated, as far as they are known.	E			
<b>2 Model and Project Documentation</b>					
2.1	Model includes documentation.	J			
2.2	Documentation includes instruction for setup and running the model.	J			

<sup>21</sup> If the plant is part of a multi-plant control scheme, a description of the overall scheme should be provided, and corresponding PPC models should be configured to control multiple plants accordingly.

<sup>22</sup> Frequency control model requirements may vary by region. Example response time may be less than 10 seconds.

<sup>23</sup> Simulation period may vary depending on the model use, but 10 seconds of simulation following an event such as a fault is a typical period.

**Recommended PSCAD Model Requirements Rev. 9**  
**May 8, 2020**

2.3	Model is supplied with a sample test case including site specific plant representation.	J	
2.4	Plant single line diagram is provided, and aligns with model	J	
2.5	Model documentation provides a clear way to identify site-specific settings and equipment configuration.	K	
<b>3 Model Usability Features</b>			
3.01	Control or hardware options are accessible to the user as applicable.	F	
3.02	Diagnostic flags are visible to the user.	F	
3.03	Model uses a timestep greater than 10 $\mu$ s.	G	
3.04	Model allows a range of simulation timesteps (ie. not restricted to a single timestep).	H	
3.05	Protection model may be disabled for troubleshooting	I	
3.06	Model accepts external reference variables for active and reactive power and voltage setpoint, and these may be changed dynamically during the simulation.	L	
3.07	Model is capable of initializing itself.	M	
3.08	Active power capacity is scalable.	N	
3.09	Active power is dispatchable.	O	
3.10	Model reaches setpoint P, Q, and V in 5 seconds or less	P	
3.11	Model compatible with Intel FORTRAN version 12 and higher.	Q	
3.12	Model compiles using PSCAD version 4.5.3 or higher.	R	
3.13	Model supports multiple instances of its own definition in a single PSCAD case.	S	
3.14	Model supports PSCAD "snapshot" feature.	T	

This work is licensed under the Creative Commons Attribution 4.0 International License. To view a copy of this license, visit <http://creativecommons.org/licenses/by/4.0/> or send a letter to Creative Commons, PO Box 1866, Mountain View, CA 94042, USA.

**Recommended PSCAD Model Requirements Rev. 9  
May 8, 2020**



3.15	Model supports the PSCAD “multiple run” feature.	U	
3.16	Model does not use PSCAD global variables.	V	
3.17	Model does not use PSCAD layer functionality	W	

---

This work is licensed under the Creative Commons Attribution 4.0 International License. To view a copy of this license, visit <http://creativecommons.org/licenses/by/4.0/> or send a letter to Creative Commons, PO Box 1866, Mountain View, CA 94042, USA.

## DETAILED INSTRUCTIONS FOR COMMUNITY OUTREACH PLAN

- The Community Outreach Plan should be as current and explanatory as possible.
  - The Community Outreach Plan information must be included in the information Proposers selected to the Final Award Group make available on their website when the website is posted publicly.
- Proposers selected to the Final Award Group must develop a public Project website, which shall include all the information on the Community Outreach Plan table for their Project.
- Proposers must develop Project presentations that include all the information on the Community Outreach Plan table (sample template provided).
- Due to the uncertainty of the duration of the COVID-19 pandemic, all Proposers are required to plan for both in-person and virtual community meetings. As we near the dates that community meetings are scheduled, in the interest of public health and safety, the conditions at the time will determine if in-person meetings or virtual meetings will be required.
  - Virtual community meetings can either be community televised, or online, but must incorporate technology that allows for live engagement and interaction between the Proposer and community participants.
- Proposers must communicate important information about the Project with stakeholders in advance of community meetings.
- Proposers must perform media outreach (earned media) and advertising (paid media) to raise community awareness of any public meeting. Media advisories (sample attached) must be issued to the following media and organizations a minimum of 30 days prior to a public meeting. Media advisories do not need to be reviewed and approved by Hawaiian Electric, but must be shared with Hawaiian Electric for awareness.
  - For Oahu Projects
    - Star Advertiser
    - Civil Beat
    - Hawaii News Now
    - KHON2 News
    - KITV4 News
    - Neighborhood Boards
  - For Maui Projects
    - Maui News
    - Maui Now
    - Civil Beat
    - Hawaii News Now
    - KHON2 News
    - KITV4 News
  - For Hawaii Island Projects
    - Hawaii Tribune Herald
    - West Hawaii Today
    - Civil Beat
    - Hawaii News Now
    - KHON2 News
    - KITV4 News
- Advertisements must be placed in area community publications.
  - Guidance from the Company can be provided upon request
  - Information in the ads must be consistent with the media advisory
- Public comments in support and in opposition to the proposed Project must be compiled and filed verbatim with the Public Utilities Commission.
- Proposers must work with and inform neighboring communities and stakeholders to provide community members timely information during ALL phases of the project, which must include,

but not be limited to the Power Purchase Agreement negotiation period, the permitting process periods, and throughout construction.

- Should any COVID-19 related events interfere with the Proposer's ability to perform the listed actions, Proposer should inform the Company immediately of such effects for Company's consideration and guidance, and possible proposal of alternate actions.

**CONTACT:**      **NAME, 808.XXX.XXXX**      **FOR IMMEDIATE RELEASE**  
**Email address**      **Date**

### **Media Advisory: Title**

Project description to be drafted by developer. Description must include the location of proposed project and supporting background information.

**Date:**      TBD

**Time:**      TBD

**Location:**      TBD

**Purpose:**      To share information about a **TYPE (e. g. CBRE solar, etc.)** renewable energy project proposed to be developed in **COMMUNITY** near **AREA REFERENCE** and to solicit public comments to be filed with the Public Utilities Commission.

**Contact:**      For more information, call **808.XXX.XXXX** or visit **(website/social media)**

**###**

Project Name

Proposer Name



# Project Benefits

- Details

# Community Benefits

- Details

# Proposed Facility Location in/near what City/Area

- Map
- Dimensions of proposed project
- Include all project components

# Project Description

- Details

# Site Layout Plan

- Project Layout
- Project Visual Simulations
  - Multiple public vantage points

# Interconnection Route

- Map

# Required Government Permits and Approvals

- Preliminary Schedule
- Opportunities for public comment

## Environmental Impacts

- Preliminary environmental assessment of the site (including any pre-existing environmental conditions)



## Cultural Impacts

- Identify any cultural, historic or natural resources that will be impacted by the project
- Describe the potential impacts on these resources
- Identify measures to mitigate such impacts.

# Where to Find More Information

- Project website
- Proposer email and contact information

# How to Provide Comments

**DRAFT**  
**REQUEST FOR PROPOSALS**  
**FOR**  
**COMMUNITY-BASED RENEWABLE ENERGY TRANCHE 1**

**ISLAND OF O‘AHU**

DECEMBER 1, 2020

Docket No. 2015-0389

*Appendix C – Code of Conduct Procedures  
Manual*



**Hawaiian  
Electric**

## I. INTRODUCTION

The Framework for Competitive Bidding ("Framework") adopted on December 8, 2006, by the Public Utilities Commission of the State of Hawaii (the "Commission") pursuant to Decision and Order No. 23121 (Docket No. 03-0372, Instituting a Proceeding to Investigate Competitive Bidding for New Generating Capacity in Hawaii) requires that the utility develop and follow a Code of Conduct whenever a utility or its affiliate seeks to advance an energy generation resource proposal in response to a request for proposals ("RFP") issued by the Company. Section III.A.4 of the Framework required the utility to submit to the Commission for review and approval (subject to modification if necessary) a code of conduct prior to the commencement of any competitive bid process under the Framework. The proposed *Code of Conduct Pertaining to the Implementation of a Competitive Bidding Process for Community-Based Renewable Energy* (the "Code of Conduct") requires the Companies to also propose this *Code of Conduct Procedures Manual* (the "Procedures Manual") to implement the requirements of the Framework and the Code of Conduct.

This Procedures Manual has been developed to outline the procedures to be followed and the policies that have been developed surrounding the implementation of the Companies' competitive bidding process for system resources. This Code of Conduct Procedures Manual has been developed for the Companies' Community-Based Renewable Energy RFPs and in accordance with the requirements of Section IV.H.9.a(iii) of the Framework and outlines requirements (1), (3) and (4) of such section, namely: (1) the protocols for communicating with Proposers, the Company Self-Build team, and others; (3) the documentation forms, including logs for any communications with proposers; and (4) other information consistent with the requirements of the solicitation process. Requirement (2) of the section, the evaluation process in detail and the methodologies for undertaking the evaluation process for the RFP are described in detail in the Community-Based Renewable Energy RFP. The bid evaluation process and methodology will consider both price/system impacts and non-price criteria in accordance with Section IV.E of the Framework and Tariff Rule 19.

The procedures and policies set forth herein have been designed to ensure that the procurement process is undertaken in a fair and equitable manner and that each Proposer is afforded an equal opportunity to participate and compete within the RFP requirements.

This Procedures Manual is intended to be followed by Company personnel in connection with implementing the Companies' solicitation process and to manage communications between Company personnel and consultants participating in the RFP processes covered by the Framework. Necessary additions, deletions, and/or changes depending on the circumstances surrounding the RFP and directions from the IO may be required.

## **II. DEFINITIONS**

- Affiliate – Any person or entity that possesses an “affiliated interest” in a utility as defined by section 269-19.5, Hawaii Revised Statutes (“HRS”), including a utility’s parent holding company but excluding a utility’s subsidiary or parent which is also a regulated utility.
- Affiliate Team – Employees and consultants of an Affiliate of the Company who prepare a proposal to be submitted to the Company in response to a Company RFP.
- ATRs – The Affiliate Transaction Requirements, issued by the Commission, applicable to the Companies and Affiliates, attached as Exhibit B to Order No. 36112 issued on January 24, 2019 in Docket No. 2018-0065.
- Code of Conduct – The *Code of Conduct Pertaining to the Implementation of a Competitive Bidding Process for Community-Based Renewable Energy* developed by Hawaiian Electric Company, Inc., Maui Electric Company, Limited and Hawaii Electric Light Company, Inc. (each, a “Company” and collectively, the “Companies”) to ensure the fairness and integrity of the competitive bidding process, in particular where the host utility or its affiliate seeks to advance its own system resource proposal in response to an RFP. The Code of Conduct follows the requirements described in Section IV.H.9.c of the Framework.

- Code of Conduct Acknowledgement – The Competitive Bidding Code of Conduct Acknowledgement of Receipt form acknowledging review of, and agreeing to abide by, the Code of Conduct and this Procedures Manual.
- Communications Log – A written record to note activities and/or information shared between the Company RFP Team or Company Self-Build Team with Shared Resources or Unassigned Company Resources, accessed via the RFP Communication Tool Kit SharePoint Site.
- Companies' Executive in Charge – The Companies' executive responsible for ensuring compliance with this Code of Conduct and serving as the point of contact for the Independent Observer for reporting any violations by the Companies' of the Code of Conduct. The Companies' Corporate Compliance Officer shall remain responsible for the Companies' independent corporate code of conduct and may support compliance matters and questions arising with employees, agents and other representatives of the Companies, e.g., conflicts of interest, with respect to this Code of Conduct.
- Company RFP Team – The Company personnel and outside consultants responsible for the development of the Company's RFPs conducted under the Framework and the evaluation of bids submitted in response to these RFPs. Subject to the transfer rules specified herein, the Company RFP Team will have fixed team members who will not have any involvement with the Company Self-Build Team for the subject RFP.
- Company Self-Build Team – The Company personnel and outside consultants responsible for the development of the Company's self-build responses to the RFP. Subject to the transfer rules specified herein, the Company Self-Build Team will have fixed team members who will not have any involvement with the Company RFP Team for the subject RFP.
- Confidential Information – Any non-public information developed and provided by the Company (i.e., proprietary system information, etc.) or Proposers during the RFP process (such non-public information may include, for example, the identity of competing Proposers, and their technical, trade or financial information). This term includes any material non-public information regarding the RFP process developed for and used during the competitive bidding solicitation process, such as the evaluation process or criteria. Confidential Information does not include

public information, such as information in the Company's public filings with the Commission.

- Director of Renewable Acquisition – The supervisor of the Division that will oversee the Company's competitive bidding process.
- Eligible Proposer – A Proposer who has met the minimum requirements and threshold requirements in the RFP necessary to remain eligible to compete in the process.
- Energy Contract Manager – The staff position(s) within the Company's Renewable Acquisition Division responsible for managing the Company RFP Team(s). The Energy Contract Manager shall be a member of the Company RFP Team he/she manages.
- Framework – The Framework for Competitive Bidding contained in Decision & Order No. 23121 issued by Commission on December 8, 2006, to establish rules for competitive bidding in response to a request for proposals when a utility seeks to acquire new generation resources.
- Independent Observer ("IO") – The neutral person or entity appointed by either the Commission or utility to monitor the utility's competitive bidding process, and to advise the utility and Commission on matters arising out of the competitive bidding process, as described in Part III.C of the Framework.
- Manager of Energy Procurement - The supervisor of the department within the Company's Renewable Acquisition Division responsible for directing the resources responsible for the implementation of the competitive bidding process pursuant to the Framework. The Manager of Energy Procurement will report to the Director of Renewable Acquisition on the status of the competitive bidding process and shall be a member of the Company RFP Team.
- Non-Price Evaluation Team – Employees and consultants of the Company who evaluate the Proposal non-price related criteria as set forth in these RFPs. Non-Price Evaluation Team members will not include any Shared Resources and will be solely made up of Company RFP Team Members.
- Non-Wires Alternative - An electricity grid project that uses non-traditional transmission and distribution (T&D) solutions, such as distributed generation (DG), energy storage, energy efficiency (EE), demand response (DR) and grid software and controls, to defer or avoid the need for conventional transmission and/or



distribution infrastructure investments.

- Price Evaluation Team – Employees and consultants of the Company who evaluate the Proposal price related criteria set forth in these RFPs. Price Evaluation Team members will not include any Shared Resources and will be solely made up of Company RFP Team Members.
- Proposer – Entity who submits or plans to submit a proposal in response to a Company-issued RFP. An Affiliate of the Company or a Company Self-Build Team participating in the RFP and submitting a proposal shall be considered a Proposer.
- RFP – A written request for proposals issued by one of the Companies to publicly solicit bids to supply future system resources to the Company pursuant to the competitive bidding process established in the Framework.
- Roster – A consolidated list of members that comprise the Company RFP Team, Company Self-Build Team, Shared Resources and Unassigned Company Resources located in the RFP Communication Tool Kit SharePoint Site. Company employee names and titles and consultants in their designated role will be identified.
- Shared Resource – Company employees and consultants who, because of the scarcity of their expertise within the Company, are designated and authorized to provide information or input to both the Company RFP Team and the Company Self-Build Team (but not any Affiliate Team) and is not a resource dedicated to either team. For example, Shared Resources may include an environmental attorney and members of the Company’s Risk Management Department.
- Unassigned Company Resource – Company employees unassigned to an essential team that may be called upon by the Company RFP Team and/or the Company Self-Build Team (but not any Affiliate Team) to assist in meeting unforeseen tasks for the RFP or the self-build proposal. For example, the Company RFP Team may be unable to evaluate an unforeseen technical specification included in a bid. In that event, the Company RFP team would need to request assistance from a Company employee or a consultant that is not already assigned to an essential team and possesses the specific expertise. Such personnel are intended to assist the requesting team only in an ad hoc manner, limited in scope and purpose to the particular task required.

### **III. STATEMENT OF OBJECTIVES**

On April 9, 2020, the Commission issued Order 37070, commencing Phase 2 of the Community-Based Renewable Energy Program ("Phase 2"). Phase 2 requires the Companies to implement competitive bidding to procure CBRE projects on all islands served by the Companies. These procurements will be concurrent and overlapping. Subsequent phases of CBRE may require further procurements through competitive bidding. Accordingly, under the Framework and the Code of Conduct, for each of the competitive procurements under the program, the Companies will undertake a detailed multi-stage review and evaluation process whereby eligible proposals will be selected based upon their ability to most cost-effectively and reliably satisfy the CBRE program requirements.

Given that multiple RFPs for CBRE, including and in addition to other RFPs currently being administered by the Companies, will be active at the same time, and because the Companies must work expeditiously, in order to consistently ensure the competitive benefits of the procurement process while continuing to provide equitable and fair consideration for all proposals, the Companies will endeavor to create, designate and maintain the Roster at all times for quicker and more decisive implementation across all active RFPs. Subject to the transfer rules specified herein, the Roster will be maintained for the durations of the RFPs. The Companies also intend that the evaluation process will be well-documented so that the results of the evaluation can be fully reviewed by an IO to confirm that all proposals were treated in a fair and consistent manner.

The Code of Conduct and this Procedures Manual address (1) communication requirements and procedures associated with the relationship between utility employees (Company RFP Team, Company Self-Build Team, Shared Resources and Unassigned Company Resources); (2) communication requirements and procedures associated with the relationship between the Company RFP Team, the Company Self-Build Team and Proposers; and (3) communication requirements associated with the relationship between Company management and the Company RFP Team.

The Code of Conduct and this Procedures Manual also include procedures for the sharing of resources, where appropriate, by the Company RFP Team and the Company

Self-Build Team for the purposes of completing their efforts to effectively evaluate an RFP or to submit a bid in response to an RFP. The small size of the Companies and limitation of resources will require specialized services, information exchange and sharing of resources in certain limited circumstances. Company personnel and consultants identified as "Shared Resources" shall be designated by the Companies for this specific purpose.

#### **IV. ORGANIZATION AND COMMUNICATION RESPONSIBILITIES**

This section outlines the RFP organizational structure for the development of the RFP and the Company self-build options and the organization's responsibilities to ensure that communications between Company personnel and consultants working on their respective RFPs or self-build projects are conducted in a fair, consistent, and equitable basis so that the Company Self-Build Team does not enjoy any unfair advantage over other Proposers responding to an RFP.

##### **A. Organization**

The Companies shall identify and maintain two separate teams to facilitate the independence and objectivity of the Company resources working on an RFP and ensure an arms-length relationship with the resources working on the Company's self-build project to avoid any real or perceived inequity in an RFP process. The two essential teams shall be the "Company RFP Team" and the "Company Self-Build Team."

Other limited Company resources, such as select staff from various functional areas of the Company that are in short supply and thus cannot be dedicated solely to either team, may be designated as "Shared Resources" to perform services for the Company RFP Team and Company Self-Build Team. Shared Resource employees are allowed to carry on with both their RFP (for either the Company RFP Team and/or the Company Self-Build Team) and regular functions throughout the resource planning process (including the development of any Company Parallel or Contingency Plan as defined in the Framework), which may require communications with or services performed for the Company Self-Build Team. Shared Resource employees, however, will not participate in the evaluation and selection process of proposals submitted in response to

an RFP. Rules for communications between Shared Resources and the essential teams are specified below.

Company employees unassigned to an RFP may be called upon by the Company RFP Team, Company Self-Build Team, or both for help to meet unforeseen tasks. After completing the Code of Conduct training, these "Unassigned Company Resources" are eligible to assist on an ad hoc basis with the requirement that all communications as an Unassigned Company Resource must be memorialized and logged in the same manner as communications with Shared Resources on the Communication Log. If an Unassigned Company Resource is called upon repeatedly for a substantial amount of assistance by a particular team, the employee should be assigned to such team or evaluated for designation as a shared resource.

**B. Essential Teams**

1. Company RFP Team. The Company RFP Team, tasked with preparing the RFP and evaluating the responses and bids in response to the RFP, will consist primarily of Director/Manager-level and other experienced employees together with possible outside consultants, with backgrounds in a number of disciplines necessary to conduct a thorough evaluation of each proposal. The Company RFP Team will be comprised of a Price Evaluation Team and a Non-Price Evaluation Team and will be prepared to evaluate proposals on the basis of their price and non-price aspects pertaining to their level of expertise. Members of the Company RFP Team will include professionals with experience in the following areas of expertise: engineering, siting/land use, environmental, transmission planning, fuel procurement, legal, financial planning, system operations, integrated resource planning, generation planning, production cost analysis, and others as needed.

The Price Evaluation Team and the Non-Price Evaluation Team will conduct their sections of the bid evaluation process separately and will not share the results of their evaluation with members of the other sub-team. Each team will submit their evaluation results to an oversight team, which will be responsible for compiling the results of the evaluations and selecting the Priority List.

The Energy Contract Manager will be responsible for directing the evaluation efforts of the Company RFP Team when the proposals are received. The Energy Contract Manager will be responsible for maintaining the documentation underlying the evaluation of each proposal as well as all communications with Proposers.

2. The Company Self-Build Team. The Company Self-Build Team, tasked with preparing any Company proposal to be submitted by the Company in response to a Company RFP, will consist primarily of Company employees, along with possible outside consultants with backgrounds in a number of disciplines necessary to complete a competitive proposal in response to a Company RFP. The members of the team will include professionals with experience in the following areas of expertise: engineering, siting/land use, environmental, transmission planning, fuel procurement, legal, financial planning, system operations, integrated resource planning, generation planning, production cost analysis, and others as needed.

3. Affiliate Team. Any Affiliate Team will be comprised solely of employees and consultants of the Affiliate and no Company employee or consultant shall serve as a member of an Affiliate Team; provided, however, that a consultant may perform services for an Affiliate and the Company so long as appropriate "walls" are established satisfactory to the Company that ensures that employees of the consultant working for the Affiliate Team do not also perform work for the Company nor communicate with employees of the consultant performing work for the Company, and vice versa. The Company will inform consultants providing services for the Company RFP Team of these separation requirements, and will seek confirmation in writing from any consultant performing services for an Affiliate and the Company that such separation requirements will be met. Affiliate Teams will be considered and treated as separate independent third-party Proposers for all purposes within any RFP and shall have no access to, interaction or communications with Shared Resources or Unassigned Company Resources for the purpose of completing a proposal in response to any RFP. Affiliate Teams shall also be subject at all times to the terms, conditions and restrictions specified in the Company's ATRs.

4. Transfers between Teams. As members of both the Company RFP

Team and the Company Self-Build Team are intended to be fixed, transfers between teams should not be permitted. However, there will be instances where a member of a particular team (whether Company RFP or Company Self-Build) transfers to a position in which he/she may be requested, as part of his/her new job responsibilities, to participate as a member of the other team. Such employee shall not be permitted to transfer from one team to the other during the pendency of any particular RFP (or stage or phase of a particular RFP). After completion of the RFP (or stage or phase of a particular RFP) under which the employee recently participated, the employee may transfer to the other team under the following conditions: (a) the employee is prohibited from disclosing any Confidential Information known to such employee as a result of being a member of his/her former team with members of the new team he/she is joining; and (b) for a period of one (1) year, such employee shall not participate or be involved in the evaluation of any subsequent stage(s) or phase(s) of a prior RFP which such employee participated in with his/her former team.

Transfers of employees between the Company and any Affiliate and their subsequent work on RFPs shall be subject to the terms, conditions and restrictions specified in the ATRs.

## **C. Communications Protocols**

### **1. Overview and General Requirements.**

The Company has developed policies and procedures governing communication between the Company RFP Team, the Company Self-Build Team, Shared Resources, the Proposers, the IO, and with the Commission regarding RFP design and bid evaluation. Bid information and evaluation data and information shall not be communicated between members of the Company RFP Team, outside parties and other employees within the Companies except to those with a business need to know.

To ensure that the competitive bidding process is fair and unbiased, that all Proposers have access to the same information so that no Proposer has an unfair advantage, and that any Company self-build and/or Affiliate proposals do not have any unfair competitive advantage over third-party bids, the Companies shall follow the Code

of Conduct whenever the utility or its Affiliate is seeking to advance a resource proposal as provided in Section IV.H.9.b of the Framework.

Each employee or consultant on the Company RFP Team, Company Self-Build Team and Shared Resources shall read, acknowledge and sign the Code of Conduct Acknowledgement. Unassigned Company Resources who are called upon by the Company RFP Team or Company Self-Build Team for help to meet unforeseen tasks shall also read, acknowledge and sign the Code of Conduct Acknowledgement.

The Company issuing the RFP will establish a shared drive on its corporate computer network designed to maintain the bid evaluation documentation and other information associated with the bidding process. Only Company RFP Team members will have access to all the files on the shared drive.

In cases where staffing and resources are limited or constrained, the Company may identify Shared Resources or those employees eligible to provide information or serve as a resource to both the Company RFP Team and the Company Self-Build Team. Specific rules to log communications with the Company RFP Team or the Company Self-Build Team are described below.

Shared Resources will not have access to the Company's shared drive established for the RFP process which will include the documentation of the bid evaluation results.

Team members should clearly mark all e-mails, documents, or other communications that contain Confidential Information and make clear which team should not receive it with the following header or a substantially similar message: "This communication contains self-build information that must be kept confidential. DO NOT copy, forward, or discuss the contents with Company RFP Team members" OR "This communication contains Company RFP Team information that must be kept confidential. DO NOT copy, forward, or discuss the contents with Company Self-Build Team members."

## **2. Communications Between the Company RFP Team and**

**Proposers, including the Company Self-Build Team and any Affiliate Team.**

During the RFP process, the Energy Contract Manager shall serve as the primary contact person for all RFP communications with Proposers. This is important from the standpoint of maintaining consistency and confidentiality of information between Proposers and the Company. For documentation and oversight purposes, all communications from Proposers must be submitted to an established website link provided by the Company (the "Company RFP website"). The IO will monitor all communications through the Company RFP website. To ensure fair and equal access to information, any Company Self-Build Team and/or Affiliate Team shall be considered a Proposer for communication purposes and any request for information from the Company Self-Build Team or Affiliate Team to the Company RFP Team shall be through the Company RFP website.

Subject to confidentiality obligations, it is the objective of the Code of Conduct that all Proposers, including the Company Self-Build Team and any Affiliate Team, receive access to information released by the Company RFP Team, whether in response to a question from a Proposer or not, at the same time.

The communications process for addressing questions and requests for information from Proposers, and for the Company RFP Team to provide information to Proposers, is provided below:

- a. Other than during Company sponsored conferences, Proposers must submit all questions to the Company RFP website or the designated RFP email address (if the Company RFP website has not been opened yet for the RFP).
- b. Questions will be reviewed and responses will be coordinated with the appropriate functional area within the Company for a response. Every reasonable effort will be made to provide responses in a timely manner.



- c. All responses, including the classification of such response, i.e., whether non-confidential or confidential as described below, will be provided to the IO for monitoring purposes via email or the PowerAdvocate messaging system. The IO may choose to comment on any response at its discretion.
  
- d. Depending on the questions received, responses may involve Confidential Information of the Company and/or Proposers. Release of any Company Confidential Information must be approved in advance by the Company executive authorized to release the Confidential Information. Any release of Company Confidential Information shall be accompanied by appropriate confidentiality and non-disclosure agreements, protective orders or other means required to maintain the confidentiality of the Company Confidential Information while still permitting its disclosure under circumstances deemed appropriate by the responsible Company executive. Other non-Company Confidential Information will not be shared without the prior written consent of the owner of such Confidential Information and the execution of appropriate confidentiality and non-disclosure agreements by all recipients of such Confidential Information. Responses will be categorized as follows:
  - i. Non-Confidential Responses: Questions and responses will either be posted directly on the Company RFP website (process-related questions or simple, non-substantive information) or a description of the information that can be made available will be posted and Proposers will be instructed to submit a request to the Company via the Company RFP website to receive a copy.
  
  - ii. Confidential Responses: Questions and a description or notice of a Confidential Information response will be posted on

the Company RFP website and Proposers will be instructed to submit a request to the Company via the Company RFP website to receive instructions on how to access the Confidential Information. The Confidential Information will only be provided to the requestor after receipt of an executed confidentiality and non-disclosure agreement. Only those who have qualified to submit a bid (i.e., Eligible Proposers) and have executed a confidentiality and non-disclosure agreement will be considered for receipt of Confidential Information.

iii. Process for Distribution of Confidential Information: Confidential Information provided in response to questions from proposers may be made available only to parties as indicated above via the following:

A. Confidential Information that is approved for exchanging on a secured access site: (1) Confidential Information may be made available on a secured website with an individual password provided to each approved Proposer; and (2) Confidential Information in documents may be transmitted to approved recipients through the Company's secure email system.

B. Confidential Information that can be made available for inspection only, but cannot be copied: There may be some types of Confidential Information that the Company may consider making available for inspection only with no copies allowed. This type of Confidential Information will be made available on Company premises for inspection only. Proposers will be advised via the Company RFP website to make arrangements with Company staff to view the Confidential Information.

C. Confidential Information that may not be released:

In the event that Proposers submit questions that require responses that the Company feels are not appropriate to provide for reasons which may include, but not be limited to, safety, security, protection of trade secrets or intellectual property rights, Proposers will be advised as such via the Company RFP website.

- e. Prior to and during the RFP, and outside of the Company RFP website protocol, developers may direct questions to the Company prior to submitting a Proposal to discuss specific questions regarding their specific Proposal. Questions shall be directed to the Company Contact for Proposals listed in the particular applicable RFP. Questions and responses that do not contain Confidential Information and which are deemed relevant to all Proposers will be published without identifying information via the Company RFP website.
- f. Once bids are received, the Company may submit information requests to Proposers to clarify their proposals or request additional information. All contacts with Proposers will be through the Company RFP website. All contacts and information exchanged will be under the oversight of the IO.
- g. A single exception to the communication process outlined above shall be instituted for the purpose of facilitating the verification of proposed project models and documentation required to perform the IRS. For this limited scope, the Company's Manager of Interconnection Services will serve as the primary contact person for all such interconnection communications with the Proposers on the Priority List, provided that all necessary confidentiality and

non-disclosure agreements are in place. The Manager of Interconnection Services and personnel in the Interconnection Services Department shall be members of the Company RFP Team. Interconnection communications will be limited to a Proposer's bid and no more information other than as necessary to facilitate such communications will be permitted. Discussion of locations of proposed projects shall be limited to that necessary only to determine the interconnection requirements of such project. The IO shall have the right to monitor all such communications in his/her discretion.

**3. Communications Between the Companies and the Commission.**

The Company's Regulatory Affairs staff will be responsible for initiating communication with the Commission regarding the RFP or the Companies' evaluation process. Regular updates may be provided to the Commission regarding the RFP process if requested.

**4. Communications Between the Company RFP Team and the IO.**

Communications between the Company RFP Team and the IO will be required for many aspects of the evaluation process. The IO is also required to maintain confidentiality of any Confidential Information. The IO will coordinate all activities through the Energy Contract Manager. The IO will be invited to participate in any meetings or discussions between the Company RFP Team and the Proposers and other communications as noted above. Sufficient notice will be provided whenever possible and teleconference and/or web conference alternatives may be utilized.

**5. Communications Between the Company RFP Team and the Company Self-Build Team or any Affiliate Team.**

Any communication between the Company RFP Team and the Company Self-Build Team or any Affiliate Team with respect to the RFP shall be handled no differently than with Proposers and other outside parties. Accordingly, the Company Self-Build Team or any Affiliate Team will be required to submit any questions or information requests to the Company RFP Team via the Company RFP website and all responses will be provided in the same manner as to other Proposers. Accordingly, as stated in Section 2 above, responses will be provided to the IO for monitoring purposes via email or the PowerAdvocate messaging system. Members of the Company RFP Team are prohibited from providing any input into the development of the self-build option by the Company or an Affiliate. Company RFP Team members are prohibited from sharing any Confidential Information (i.e., detailed evaluation criteria, other proposals, etc.) with any Company Self-Build or Affiliate Teams except in accordance with the procedures in the Code of Conduct, this Manual or the RFP.

Company RFP Team members and Company Self-Build Team members may continue to work with each other on projects not related to the RFP. Further, members of each respective team do not have to be physically separated from each other, but members of each team must make reasonable efforts to keep all Confidential Information (including electronic data) secure and inaccessible to the other team.

Company RFP Team members and Affiliate Team members may continue to work with each other on matters not related to the RFP as permitted under the ATRs.

## **6. Communications among the Company RFP Team, the Company Self-Build Team and Shared Resources.**

Shared Resources may provide services to the Company RFP Team and the Company Self-Build Team (but not any Affiliate Team). Shared Resources shall be limited as much as possible to instances where Company resources cannot provide a dedicated member to the Company RFP Team and the Company Self-Build Team at the same time and still provide the necessary functions of its area to the Company as a whole. Shared

Resources are expressly prohibited from providing any information developed on behalf of the Company RFP Team to the Company Self-Build Team or any information developed on behalf of the Company Self-Build Team with the Company RFP Team, except through the formal communication process outlined above, i.e., through the Company RFP website.

Additionally, a written record of the time, date and substance of all conversations, data and written material directly or indirectly exchanged with the Company RFP Team or the Company Self-Build Team that pertain to the RFP shall be maintained on the Communications Log. The RFP Communication Tool Kit SharePoint Site will be set up and managed by the Energy Contract Manager to provide an easy to use and understand mechanism to log and memorialize these conversations.

Shared Resources will not have direct access to the Company's shared drive developed for the RFP process which will include documentation of the bid evaluation results.

**7. Communications between the Company RFP Team, the Company Self-Build Team and any Unassigned Company Resource or consultant that is not a Shared Resource.**

There may be times where a Company RFP or Company Self-Build team (but not an Affiliate Team) member may need ancillary or other ministerial or administrative assistance that requires communication and/or assistance from Company personnel who are neither on any team nor considered a Shared Resource. Under those circumstances, such personnel may assist the requesting team member on an ad hoc basis upon the following conditions:

- a. The essential team member making the request must inform the Company personnel that sharing of the requested information or assistance with the other team, be it the Company RFP or Company Self-Build Team, is expressly prohibited under the Code of Conduct.

b. The assisting Company personnel shall complete the Code of Conduct training and sign the Code of Conduct Acknowledgement.

c. The assisting Company personnel shall be directed to the Roster provided by such requesting team member to determine and/or confirm the restrictions on communication with the other team members. The essential team member making the request will ensure the Roster is updated by the Energy Contract Manager to include the assisting Company personnel.

d. A written record of the time, date and substance of all conversations, data and written material directly or indirectly exchanged with the Company RFP Team or the Company Self-Build Team that pertain to the RFP shall be maintained on the Communication Log. The RFP Communication Tool Kit SharePoint Site will be set up and managed by the Energy Contract Manager to provide an easy to use and understand mechanism to log and memorialize these conversations.

e. If assistance from an Unassigned Company Resource becomes more than occasional or more substantive than ancillary, ministerial or administrative services, the Unassigned Company Resource should be considered for inclusion on the team that he/she has been assisting on such basis. Additionally, the Unassigned Company Resource may also be considered for inclusion as a Shared Resource. Members of the Company RFP Team and/or Company Self-Build Team shall consult with the Company executive for resolution.

**8. Communications between the Company RFP Team, the Company Self-Build Team and Company Management.**

The Company RFP Team and the Company Self-Build Team will necessarily require management approval of the RFP and the Company Self-Build Team proposal. Because of the size of the Company, it may be possible that a single employee (at whatever level) (the "Approver") may have approval responsibility for matters affecting the RFP and the Company Self-Build Team proposal. Approvers in this situation must use their best judgment in making decisions reviewing and approving matters for the respective teams. The Code of Conduct must be adhered to in these situations and the Approver must not communicate matters learned from the Company RFP Team with the Company Self-Build Team.

If an Approver feels that he/she cannot manage this potential conflict, the Approver is recommended to consult with his/her immediate supervisor to determine whether such higher authority could be appointed with the task of reviewing and approving matters for a designated team, either the Company RFP Team or the Company Self-Build Team. In matters where a team of employees (including one or more Approvers) is responsible for reviewing and approving matters for the respective teams, approving employees (from whatever level, including executives) with information from reporting personnel beneath them from both the Company RFP Team and the Company Self-Build Team may consider recusing himself/herself from the decision making if such employee cannot objectively make a decision on the matter.

Finally, an Approver may be a member of the Company RFP Team and have a subordinate reporting to him/her that is a member of the Company Self-Build Team (or vice versa). In such situations, because the Code of Conduct prohibits communication between the teams, the Approver must recuse himself/herself from the decision making and request his/her manager to review and approve the matter in his/her place.

In all instances, it is possible that any particular situation above may be addressed and/or resolved by the terms and conditions of the Company's internal code of conduct implemented for all employees and consultants of the Company. As appropriate, an Approver or any other team member, Energy Contract Manager or Company executive in Charge may involve the Company's Corporate Compliance Officer for input and possible



resolution under the Company's internal corporate code of conduct.

**V. WHEN THE CODE OF CONDUCT BECOMES EFFECTIVE**

A. Prior to development of the requirements for any particular RFP, the Code of Conduct for that RFP will be activated. However, if the Company Self-Build Team determines at any time that it will not pursue a self-build option for a particular RFP, the Code of Conduct may be de-activated.

B. Upon the activation of the Code of Conduct, members of the Company RFP Team and the Company Self-Build Team must then conduct activities on the RFP or self-build process in compliance with the Code of Conduct. Once identified and having commenced work, no information may be shared outside the respective team members with respect to the RFP or a self-build option except through the formal communication processes outlined above.

C. Immediately upon assignment to a Company team (RFP or Self-Build), designation as a Shared Resource, or request to assist as an Unassigned Company Resource, each such employee or consultant must review this Manual, and sign the Code of Conduct Acknowledgement.

D. Within the RFP process, after a member has been assigned to a particular Company team (RFP or Self-Build), he or she will not be able to transfer to the other Company team during the pendency of any particular RFP (or stage or phase of a particular RFP). It is the responsibility of each team to fill vacant team positions with employees that have not been previously assigned as a team member for a team until the PPA negotiations have been concluded and the final contracts are executed.

E. Each employee and consultant working on the RFP shall review the Code of Conduct and sign the Code of Conduct Acknowledgement attesting to his/her compliance with the Code of Conduct until the employee is no longer working in the position he/she was in while working on the RFP.

F. The Energy Contract Manager will be responsible for maintaining the Roster and the signed Code of Conduct Acknowledgements. The Company Executive in Charge shall be responsible for ensuring compliance with the Code of Conduct and shall have the written authority and obligation to enforce the Code of Conduct.

## **VI. IMMEDIATE ACTIONS UPON ACTIVATION OF THE CODE OF CONDUCT**

The following items are required to be completed as soon as possible after activation of the Code of Conduct, but no later than the designated events specified for each item below.

A. Prior to development of the requirements for any particular RFP, a Roster listing employee (with their title) and consultants in their designated role; Company RFP Team, Company Self-Build Team, Shared Resource or Unassigned Company Resource. When the IO is appointed, this Roster shall be provided to him/her. The Roster shall be placed in the RFP Communication Tool Kit SharePoint Site so that any Company personnel can access the database to determine the identity of the respective teams and Shared Resources.

B. Upon the finalization of the Roster for the RFP, the Energy Contract Manager shall verify that all employees (whether full-time, part-time, temporary, or contract) and consultants involved in the competitive bidding process, such as members of the Company RFP Team, the Company Self-Build Team, Shared Resources or Unassigned Company Resources, have acknowledged receipt of the Code of Conduct and his or her responsibility to comply with the Code of Conduct by submitting the Code of Conduct Acknowledgement (with electronic acknowledgment being acceptable). If an employee or consultant is later added to a team, the Energy Contract Manager shall also verify that such employee or consultant has submitted the Code of Conduct Acknowledgment.

C. Prior to any solicitation for comments or questions to the RFP, establishment of the Company email address to accept requests for information from Proposers, including the Company Self-Build Team or any Affiliate Team.

D. Prior to the drafting of any documents for any particular RFP, establishment of the Company-secured site that houses the accessible database (such as SharePoint).

## **VII. WHEN THE CODE OF CONDUCT TERMINATES**

- A. The Code of Conduct for a specific RFP will terminate after the following two conditions are met when:
- a. the final contract(s) for RFPs conducted under the Framework with the successful proposer(s) is/are executed, or when written notice of termination of the RFPs to be conducted under the Framework is provided by the Manager of Energy Procurement or his/her designee to the IO and the Commission, and
  - b. a certification of Code of Conduct compliance by all employees participating in the specific RFP process is submitted by affidavit by the Company Executive in Charge.

## **VIII. DOCUMENTATION FORMS**

The following documentation forms may be utilized by those Company personnel involved in the RFP. These forms may be amended from time to time as necessary. Additional forms may also be developed as determined necessary.

- Code of Conduct Acknowledgement
- Communications Log
- Roster

## **IX. APPLICABILITY OF THE ATRs**

Except as specifically made applicable under Section V.C.1.i of the ATRs with respect to wholesale power procurement from Affiliates, the ATRs shall not apply to RFP matters covered by the Framework, the Code of Conduct and this Procedures Manual as it relates to the Companies' interactions between the Company RFP Teams and Affiliate Teams. Reference to the ATRs in the Code of Conduct and/or this Manual are specifically

for matters outside the Companies' administration of the RFP; provided, however, that such applicability may be revised as necessary and as may be directed by the Commission for any RFP.<sup>1</sup>

---

<sup>1</sup> See Decision and Order No. 35962, filed on December 19, 2018, in Docket 2018-0065, at 56-57.

**DRAFT**  
**REQUEST FOR PROPOSALS**  
**FOR**  
**COMMUNITY-BASED RENEWABLE ENERGY TRANCHE 1**  
**ISLAND OF O‘AHU**

DECEMBER 1, 2020

Docket No. 2015-0389

*Appendix D – PowerAdvocate User Information*



**Hawaiian  
Electric**

## Sourcing Intelligence Quick Start for Suppliers

### Logging In

1. Launch a web browser and go to [www.poweradvocate.com](http://www.poweradvocate.com)
2. Click the orange **Login** button.
3. Enter your account **User Name** and **Password** (both are case-sensitive) and click **Login**.
4. Click the **Events** tab if it is not already displayed.

### Dashboard

Your Dashboard lists the events you have been invited to. A line divides currently accessible events from others.



Click to view Events

Click to view the event's Status tab

Buyer filter

Navigation bar

Buying entity

Number of unread/total messages

Click to view the event's Messaging tab

Click numbers to view event tabs

Datashheet available

No datashheet available

- Click an event name to view its Status tab, which displays a summary of your activity and key event dates. To view specific details of an event, click the buttons 1-5 to view the corresponding tab.
- To return to the Dashboard, click **Dashboard** in the navigation bar at the top of the window.
- An event will not appear on your Dashboard until you have been added as a participant.



## Downloading Bid Packages

All of the Buyer's bid package documents (if any) are centrally stored on the PowerAdvocate Platform. To view bid documents, click "1" on your Dashboard or on the **1. Download Documents** tab from within the event.

Document Description	Issue Date	Ref ID	File Name	File Size	Download
<input type="checkbox"/> Pre Bid Test Doc	01/15/18		Pre_Bid_Test_Doc.docx	11.63 KB	

- You can access the **Bid** sub-tab after the event opens. You can access Buyer documents before the event is opened from the **Pre-Bid** sub-tab, if the Buyer utilizes this feature.
- To view or download a document, click the file name.
- To download multiple documents:
  1. Select the checkbox in the Download column for each document you wish to download or click **Select All**.
  2. Click **Download Selected Files**.

## Uploading Documents

To upload your documents, click "2" on your Dashboard, or on the **2. Upload Documents** tab from within the event.

- Do not upload any files to the Pre-Bid tab.
- To upload a document to the Bid tab:
  1. Specify a **Document Type** (Reference ID can be left blank).
  2. Click **Choose File**, navigate to and select the document, and then click Open; multiple files can also be compressed into one .zip file for upload.
  3. Click **Submit Document**.



## Datasheets

Datasheets (3. Commercial Data, 4. Technical Data, 5. Pricing Data) will not be used in this RFP event. All Proposal information will be uploaded for submission through the 2. Upload Documents tab. Buttons/tabs are grayed out if the event is not using a particular type of datasheet.

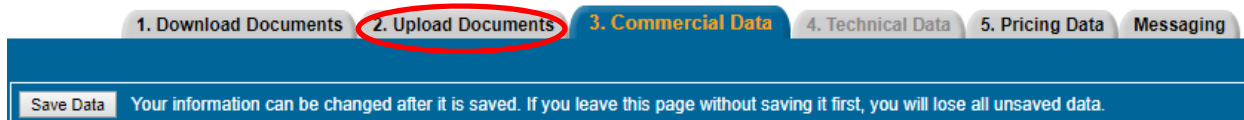

## Communicating with the Bid Event Coordinator /Company Contact

Suppliers should use Email to contact the Bid Event Coordinator/Company Contact while the bid event is open. In these CBRE RFPs, PowerAdvocate Messaging will not be used.

## Getting More Information

- Click **Help** on the navigation bar to display online help.



- Supplier documentation can be downloaded from the online help system.
- Call PowerAdvocate Support at 857-453-5800 (Mon-Fri, 8 a.m. to 8 p.m. Eastern Time) or e-mail [support@poweradvocate.com](mailto:support@poweradvocate.com).



**DRAFT**  
**REQUEST FOR PROPOSALS**  
**FOR**  
**COMMUNITY-BASED RENEWABLE ENERGY TRANCHE 1**  
**ISLAND OF O‘AHU**

DECEMBER 1, 2020

Docket No. 2015-0389

*Appendix E – Mutual Confidentiality and  
Non-Disclosure Agreement*

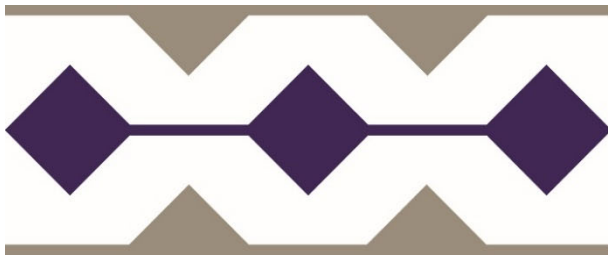

**Hawaiian  
Electric**

**APPENDIX E**  
**MUTUAL CONFIDENTIALITY AND NON-DISCLOSURE AGREEMENT**  
Independent Power Producers – (“IPPs”)

This Mutual Confidentiality and Non-Disclosure Agreement (this “Agreement”) is effective as of \_\_\_\_\_, 20\_\_\_\_ (the “Effective Date”) between [INSERT NAME OF IPP], a [State of incorporation/organization] [type of entity] (“IPP”) and Hawaiian Electric Company, Inc., Maui Electric Company, Limited, and Hawaii Electric Light Company, Inc., each a Hawaii corporation (collectively, the “Companies”). In consideration of the mutual promises contained in this Agreement, including the provision of Confidential Information (as defined below) by either party to the other hereunder, and other good and valuable consideration, the receipt and sufficiency of which are hereby acknowledged, the parties agree as follows:

1. Background

The Companies have or intend to issue a Request for Proposals (“RFP”) for Community-Based renewable energy projects. The IPP has or intends to submit one or more proposals for a nominal [ ] MW [TYPE OF FACILITY] facility located at [LOCATION] on the island of Oahu, State of Hawai‘i (“Proposal”).

In connection with the IPP’s proposed project, the Companies may conduct an interconnection requirements study (“IRS”) to establish the requirements for interconnection of the IPP’s proposed project to the Companies’ electric grid. The RFP process may also result in the award of a potential power purchase agreement, the terms of which must be agreed upon by the parties (“PPA Negotiations”). For purposes of this Agreement the term “Project” refers to the RFP, Proposal, potential IRS and PPA Negotiations.

In order to evaluate the Project, either party may from time to time provide to the other party certain Confidential Information. The parties are willing to provide such Confidential Information to each other upon the terms and conditions of this Agreement.

2. Confidential Information

Except as set forth in Section 3 (Exclusions from Confidential Information) below, “Confidential Information” means all non-public, confidential or proprietary information disclosed by either party (the “Provider”) to the other party (a “Recipient”) its affiliates and its and their directors, officers, employees, agents, advisors, consultants (including, without limitation, financial advisors, counsel and accountants) and controlling entities or individuals (collectively, “Representatives”) whether disclosed orally or disclosed or accessed in written, electronic or other form of media, and whether or not marked or otherwise identified as “confidential,” including, without limitation:

(a) all information concerning the Provider and its affiliates’, and their customers’, suppliers’ and other third parties’ past, present and future business affairs including, without limitation, finances, customer information, supplier information, products, services, designs,

processes, organizational structure and internal practices, forecasts, sales and other financial results, records and budgets, business, marketing, development, sales and other commercial information and strategies;

(b) information concerning the Companies' generation, transmission, and distribution systems (e.g., engineering and operating characteristics of the Companies' transmission lines and substations) ("Critical Infrastructure Confidential Information");

(c) the Provider's unpatented inventions (whether or not they are patentable), ideas, methods and discoveries, techniques, formulations, development plans, trade secrets, know-how, unpublished patent applications and other confidential intellectual property;

(d) all designs, specifications, documentation, components, source code, object code, images, icons, audiovisual components and objects, schematics, drawings, protocols, processes, and other visual depictions, in whole or in part, of any of the foregoing;

(e) any third-party confidential information included with, or incorporated in, any information provided by the Provider to the Recipient or its Representatives; and

(f) all notes, analyses, compilations, reports, forecasts, studies, samples, data, statistics, summaries, interpretations and other materials ("Notes") prepared by or for the Recipient or its Representatives that contain, are based on, or otherwise reflect or are derived from, in whole or in part, any of the foregoing.

### 3. Exclusions from Confidential Information

Except as required by applicable federal, state, or local law or regulation, the term "Confidential Information" as used in this Agreement shall not include information that:

(a) at the time of disclosure is, or thereafter becomes, generally available to and known by the public other than as a result of, directly or indirectly, any violation of this Agreement by the Recipient or any of its Representatives; provided, however, that Confidential Information shall not be disqualified as Confidential Information (i) merely because it is embraced by more general or generic information which is in the public domain or available from a third party, or (ii) if it can only be reconstructed from information taken from multiple sources, none of which individually shows the whole combination (with matching degrees of specificity);

(b) at the time of disclosure is, or thereafter becomes, available to the Recipient on a non-confidential basis from a third-party source, provided that such third party is not and was not prohibited from disclosing such Confidential Information to the Recipient by a contractual or other obligation to the Provider;

(c) was known by or in the possession of the Recipient or its Representatives, as established by documentary evidence, prior to being disclosed by or on behalf of the Provider pursuant to this Agreement;

(d) was or is independently developed by the Recipient, as established by documentary evidence, without reference to or use of, in whole or in part, any of the Provider's Confidential Information; or

(e) was or is learned of established entirely from public sources, as established by documentary evidence, without reference to or use of, in whole or in part, any of the Provider's Confidential Information.

The parties acknowledge and understand that the confidentiality obligations of this Agreement apply only to the Confidential Information shared in connection with the Project. The parties may share other information with each other under other agreements, provisions or understandings which are not related to the Project. Such information sharing shall be subject to the provisions of the agreements and confidentiality provisions associated thereto and this Agreement shall not be construed to infringe upon or apply to such agreements or provisions.

#### 4. Non-Disclosure of Confidential Information

Unless otherwise agreed to in writing by the Provider, the Recipient agrees as follows:

(a) except as required by law, not to disclose or reveal any Confidential Information to any person or entity other than its Representatives who are actively and directly participating in the evaluation of the Project or who otherwise need to know the Confidential Information for the purpose of evaluating the Project.

(b) not to use Confidential Information for any purpose other than in connection with its evaluation of the Project or the consummation of the Project.

(c) except as required by law, not to disclose to any person or entity (other than those of its Representatives who are actively and directly participating in the evaluation of the Project or who otherwise need to know for the purpose of evaluating the Project) any information about the Project, or the terms or conditions or any other facts relating thereto, including, without limitation, the fact that discussions are taking place with respect thereto or the status thereof, or the fact that Proprietary Information has been made available to the Recipient or its Representatives.

(d) to use diligent efforts to safeguard and protect the confidentiality of the Confidential Information, including, at minimum, implementing the same commercial measures that the Recipient uses to protect its own confidential information. Before disclosing the Confidential Information to any Representative, the Recipient will inform such Representative of the confidential nature of such information, their duty to treat the Confidential Information in accordance with this Agreement and shall ensure that such Representative is legally bound by the terms and conditions of this Agreement or subject to confidentiality duties or obligations to the Recipient that are no less restrictive than the terms and conditions of this Agreement.

(e) Any provision herein to the contrary notwithstanding, the Companies may disclose Confidential Information to the State of Hawai'i Public Utilities Commission ("Commission")

and/or the State of Hawai'i Division of Consumer Advocacy (including their respective staffs) provided that such disclosure is made under a protective order entered in the docket or proceeding with respect to which the disclosure will be made or any general protective order entered by the Commission.

5. Required Disclosure and Notice

If the parties or any of their Representatives become legally compelled (by deposition, interrogatory, request for documents, subpoena, civil investigative demand, court order, or similar process) to disclose any of the Confidential Information, the compelled party shall undertake reasonable efforts to provide the other party with notice within three (3) business days of such requirement or advice prior to disclosure so that the other party may (a) seek a protective order or other appropriate remedy, (b) consult with the other party with respect to the compelled party taking steps to resist or narrow the scope of such requirement or advice, and/or (c) waive compliance, in whole or in part, with the terms of this Agreement. If such protective order or other remedy is not obtained, or the other party waives compliance with the provisions hereof, the compelled party agrees to furnish only that portion of the Confidential Information which it is legally required to so furnish and, at the request of the other party, to use reasonable efforts to obtain assurance that confidential treatment will be accorded such Confidential Information, it being understood that such reasonable efforts shall be at the cost and expense of the party whose Confidential Information has been sought. In any event, neither the IPP nor any of its Representatives will oppose action by the Companies to obtain an appropriate protective order or other reliable assurance that confidential treatment will be accorded the Confidential Information.

6. Return or Destruction of Confidential Information

At any time during or after the term of this Agreement, at the Provider's written request, and in any event, upon the termination of the Agreement, the Recipient shall certify within ten (10) business days that it has destroyed all Confidential Information by using industry standard data elimination methods used to prevent unauthorized disclosure of information, and for Personally Identifiable Information (defined as personally identifiable information of individuals, and any information that may be used to track, locate or identify such individuals (or which is otherwise protected by privacy laws), including any automatically generated information (such as IP addresses and other customer identifiers) that identifies or is unique or traceable to a particular individual or computer or other electronic device capable of accessing the internet, including without limitation, name, address, telephone number, social security number, credit card account numbers, email addresses, user identification numbers or names and passwords, which is disclosed to the Recipient or its subcontractors in connection with this Agreement by the Provider, which products and services are used or intended to be used for personal, family or household purposes), such methods shall be consistent with Hawaii Revised Statutes Chapter 487-R; provided, however, that with respect to Confidential information in tangible form, the Recipient may return such Confidential Information to the Provider within ten (10) business days in lieu of destruction. The Recipient's sole obligation with respect to the disposition of any Notes shall be to redact or otherwise expunge all such Confidential Information from such Notes and certify to the Provider that it has so redacted or expunged the Confidential Information. Notwithstanding the foregoing, with respect to any Confidential Information stored in Recipient's disaster recovery backups or

other electronic archives, Recipient is not required to destroy such Confidential Information if it would impose a material cost or burden; provided, however, such Confidential Information shall be destroyed when such archives are destroyed in accordance with Recipient's records retention policies.

7. Authority

Each party represents and warrants that it has full power and authority to enter into and perform this Agreement, and the person signing this Agreement on behalf of each has been properly authorized and empowered to enter into this Agreement, understands it and agrees to be bound by it.

8. No Representations or Warranties

Neither the Provider nor any of its Representatives make any express or implied representation or warranty as to the accuracy or completeness of any Confidential Information disclosed to the Recipient hereunder, and the Recipient agrees that it is not entitled to rely on the accuracy or completeness of any Confidential Information. Neither the Provider nor any of its Representatives shall be liable to the Recipient or any of its Representatives relating to or arising from the use of any Confidential Information or for any errors therein or omissions therefrom. Notwithstanding the foregoing, the Recipient shall be entitled to rely solely on such representations and warranties regarding Confidential Information as may be made to it in any final agreement relating to the Project, subject to the terms and conditions of such agreement.

9. No Other Obligations

Neither this Agreement nor the disclosure of the Confidential Information shall result in any obligation on the part of either party to enter into any further agreement with the other with respect to the subject matter hereof or otherwise, to purchase any products or services from the other, or to require either party to disclose any further information to the other. Nothing in this Agreement shall be deemed to constitute either party hereto as partner, agent or representative of the other party or to create any fiduciary relationship between the parties. Either party may offer products or services which are competitive with products or services now offered or which may be offered by the other. Subject to the express terms and conditions of this Agreement, neither this Agreement nor discussions and/or communications between the parties will impair the right of either party to develop, make, use, procure, and/or market any products or services, alone or with others, now or in the future, including those which may be competitive with those offered by the other. Whether or not the Project is consummated, neither party shall issue a press release or release any information to the general public concerning such transaction or the absence thereof without the express prior written consent of the other, and the parties agree that neither party will use the other's name whether by including reference to the other in any press release, list of customers advertising that its services are used by Companies or otherwise, without written authorization by the respective party's authorized representative.

10. Property Rights in Confidential Information

All Confidential Information shall remain the sole and exclusive property of the Provider and nothing in this Agreement, or any course of conduct between the parties shall be deemed to grant to the Recipient any license or rights in or to the Confidential Information of the Provider, or any part thereof. Unless otherwise expressly agreed in a separate license agreement, the disclosure of Confidential Information to the Recipient will not be deemed to constitute a grant, by implication or otherwise, of a right or license to the Confidential Information or to any patents or patent applications of the Provider.

11. Publicly Traded

The IPP acknowledges that the Companies' holding company is a publicly traded company, and that Confidential Information of the Companies may constitute material, non-public information with respect to the Companies. The IPP understands, and will advise its Representatives to whom Confidential Information of the Companies is disclosed, of the restrictions imposed by the United States securities laws on (a) the purchase or sale of securities by any person in possession of material, non-public information with respect to such securities, and (b) the communication of material, non-public information with respect to securities to a person who may purchase or sell such securities in reliance upon such information.

12. Remedies

(a) Each party acknowledges and agrees that any breach or threatened breach of this Agreement may give rise to an irreparable injury to the Provider or its Representatives, for which compensation in damages is likely to be an inadequate remedy. Accordingly, in the event of any breach or threatened breach of this Agreement by the Recipient or its Representatives, the Provider shall be entitled to seek equitable relief, including in the form of injunctions and orders for specific performance, in addition to all other remedies available at law or in equity.

(b) In the event that the Recipient learns of dissemination, disclosure, or use of the Confidential Information which is not permitted by this Agreement, the Recipient shall notify the Provider immediately in writing and shall use reasonable efforts to assist the Provider in minimizing damages from such disclosure. Such remedy shall be in addition to and not in lieu of any other rights or remedies available to the Provider at law or in equity.

13. Cumulative Remedies

No rights or remedy herein conferred upon or reserved to either party hereunder is intended to be exclusive of any other right or remedy, and each and every right and remedy shall be cumulative and in addition to any other right or remedy under this Agreement, or under applicable law, whether now or hereafter existing.

14. Notice

(a) By delivering written notice, either party may notify the other that it no longer wishes to receive or provide Confidential Information. Any further information received or

provided by the party who received such notice following receipt of such notice, shall not be subject to the protection of this Agreement.

(b) All notices, consents and waivers under this Agreement shall be in writing and will be deemed to have been duly given when (i) delivered by hand, (ii) sent by electronic mail (“E-mail”) (provided receipt thereof is confirmed via E-mail or in writing by recipient), (iii) sent by certified mail, return receipt requested, or (iv) when received by the addressee, if sent by a nationally recognized overnight delivery service (receipt requested), in each case to the appropriate addresses and E-mail Addresses set forth below (or to such other addresses and E-mail addresses as a party may designate by notice to the other party):

**(1) Companies:**

**By Mail:**

Hawaiian Electric Company, Inc.  
P.O. Box 2750  
Honolulu, Hawaii 96840  
Attn: Manager of Procurement, Renewable Acquisition Division

**Delivered By Hand or Overnight Delivery:**

Hawaiian Electric Company, Inc.  
Central Pacific Plaza  
220 South King St, 21<sup>st</sup> Floor  
Honolulu, HI 96813  
Attn: Manager of Procurement, Renewable Acquisition Division

**By E-mail:**

Hawaiian Electric Company, Inc.  
Attn: Manager of Procurement, Renewable Acquisition Division  
Email: [renewableacquisition@hawaiianelectric.com](mailto:renewableacquisition@hawaiianelectric.com)

With a copy to:

**By Mail:**

Hawaiian Electric Company, Inc.  
Legal Department  
P.O. Box 2750  
Honolulu, Hawaii 96840

**Delivered By Hand or Overnight Delivery:**

Hawaiian Electric Company, Inc.  
American Savings Bank Tower  
1001 Bishop Street, Suite 1100  
Honolulu, Hawaii 96813  
Attn: Legal Department



By E-mail:

Hawaiian Electric Company, Inc.  
Legal Department  
Email: [legalnotices@hawaiianelectric.com](mailto:legalnotices@hawaiianelectric.com)

**(2) [IPP]**

By Mail:

[INSERT ADDRESS/CONTACT]

Delivered By Hand or Overnight Delivery:

[INSERT ADDRESS/CONTACT]

By E-mail:

[INSERT ADDRESS/CONTACT]

With a copy to:

By Mail:

[INSERT ADDRESS/CONTACT]

Delivered By Hand or Overnight Delivery:

[INSERT ADDRESS/CONTACT]

By E-mail:

[INSERT ADDRESS/CONTACT]

15. No Waiver

Except as otherwise provided in this Agreement, no delay or forbearance of a party in the exercise of any remedy or right will constitute a waiver thereof, and the exercise or partial exercise of a remedy or right shall not preclude further exercise of the same or any other remedy or right.

16. Governing Law

This Agreement is made under, governed by, construed and enforced in accordance with, the laws of the State of Hawaii. Any action brought with respect to the matters contained in this Agreement shall be brought in the federal or state courts located in the State of Hawaii. Each party agrees and irrevocably consents to the exercise of personal jurisdiction over each of the parties by such courts and waives any right to plead, claim or allege that the State of Hawaii is an inconvenient forum or improper venue.

17. Attorneys' Fees and Costs

If there is a dispute between the parties and either party institutes a lawsuit, arbitration, mediation or other proceeding to enforce, declare, or interpret the terms of this Agreement, then the prevailing party in such proceeding shall be awarded its reasonable attorneys' fees and costs.

18. Assignment Prohibited

This Agreement shall be binding upon and inure to the benefit of the parties hereto and their respective successors, legal representatives, and permitted assigns. Neither party shall have the right to assign any of its rights, duties or obligations under this Agreement, by operation or law or otherwise, without the prior written consent of the other party. Any purported assignment in violation of this section shall be null and void.

19. No Third Party Beneficiaries

Nothing expressed or referred to in this Agreement will be construed to give any person or entity other than the parties any legal or equitable right, remedy, or claim under or with respect to this Agreement or any provision of this Agreement. This Agreement and all of its provisions and conditions are for the sole and exclusive benefit of the parties and their successors and permitted assigns.

20. Entire Agreement

This Agreement constitutes the entire agreement between the parties relating to the subject matter hereof, superseding all prior and contemporaneous agreements, understandings or undertakings, oral or written with respect to the subject matter. Any amendment or modification of this Agreement or any part hereof shall not be valid unless in writing and signed by the Parties. Any waiver hereunder shall not be valid unless in writing and signed via by the party against whom waiver is asserted.

21. Term and Survival

This Agreement shall remain in full force and effect for a period of two (2) years from the Effective Date. All confidentiality obligations within this Agreement shall survive following expiration or termination of this Agreement.

22. Severability

If any term or provision of this Agreement, or the application thereof to any person, entity or circumstances is to any extent invalid or unenforceable, the remainder of this Agreement, or the application of such term or provision to persons, entities or circumstances other than those as to which it is invalid or unenforceable, shall not be affected thereby, and each term and provision of this Agreement shall be valid and enforceable to the fullest extent permitted by law, and the parties will take all commercially reasonable steps, including modification of the Agreement, to preserve the economic "benefit of the bargain" to both parties notwithstanding any such aforesaid invalidity or unenforceability.

23. Negotiated Terms

The parties agree that the terms and conditions of this Agreement are the result of negotiations between the parties and that this Agreement shall not be construed in favor of or against any party by reason of the extent to which any party or its professional advisors participated in the preparation of this Agreement.

24. Counterparts and Electronic Signatures

This Agreement may be executed in counterparts, each of which shall be deemed an original, and all of which shall together constitute one and the same instrument binding all parties notwithstanding that all of the parties are not signatories to the same counterparts. For all purposes, duplicate unexecuted and unacknowledged pages of the counterparts may be discarded and the remaining pages assembled as one document. The parties agree that this Agreement and any subsequent writings, including amendments, may be executed and delivered by exchange of executed copies via E-mail or other acceptable electronic means, and in electronic formats such as Adobe PDF or other formats mutually agreeable the parties which preserve the final terms of this Agreement or such writing. A party's signature transmitted by E-mail or other acceptable electronic means shall be considered an "original" signature which is binding and effective for all purposes of this Agreement.

*[Signature Page Follows]*

IN WITNESS WHEREOF, each party has caused this Agreement to be executed on its behalf by a duly authorized representative, all as of the Effective Date.

HAWAIIAN ELECTRIC COMPANY, INC.

By: \_\_\_\_\_  
Print Name: \_\_\_\_\_  
Its: \_\_\_\_\_

MAUI ELECTRIC COMPANY, LIMITED

By: \_\_\_\_\_  
Print Name: \_\_\_\_\_  
Its: \_\_\_\_\_

HAWAII ELECTRIC LIGHT COMPANY, INC,

By: \_\_\_\_\_  
Print Name: \_\_\_\_\_  
Its: \_\_\_\_\_

“Companies”

[Insert Name of IPP]

\_\_\_\_\_  
By: \_\_\_\_\_  
Print Name: \_\_\_\_\_  
Its: \_\_\_\_\_

“IPP”

**DRAFT**  
**REQUEST FOR PROPOSALS**  
**FOR**  
**COMMUNITY-BASED RENEWABLE ENERGY TRANCHE 1**  
**ISLAND OF O‘AHU**

DECEMBER 1, 2020

Docket No. 2015-0389

*Appendix F – Description of Available Sites*



**Hawaiian  
Electric**

**HAWAIIAN ELECTRIC  
COMMUNITY-BASED RENEWABLE ENERGY PROJECTS RFP  
DESCRIPTION OF AVAILABLE SITES**

**Land Request for Information**

On June 15, 2020, Hawaiian Electric issued a Land Request for Information (“Land RFI”) seeking information on available land and rooftop space for potentially siting future utility scale renewable energy projects on the islands of O‘ahu, Maui, Moloka‘i, and Hawai‘i. This effort is a new solicitation from the previous Land RFI that was issued on December 12, 2016 in advance of the Company’s Stage 1 and Stage 2 RFPs. The information that has been gathered through this RFI is available upon request by following the instructions at <http://hawaiianelectric.com/landrfi>.

This information is being provided for proposers’ consideration only. Project proposals submitted in response to this RFP are not required to be sited at a location identified through the Land RFI. Hawaiian Electric also makes no representations as to the suitability of the listed sites for renewable energy production with regard to resource quality, interconnection constraints, zoning and permitting issues, community support, or other issues. Proposers should perform their own evaluation of these factors in determining whether a site is suitable for renewable energy project development. After further evaluation, proposers that are interested in any of the identified sites are invited to engage in further discussions directly with landowners to negotiate any required rights to use the property.

**Additional Information**

Additionally, the following links to a few publicly available resources relating to renewable energy project siting and development from the Hawai‘i State Energy Office are being provided for use at proposers’ sole discretion:

**Project Permitting Assistance and Resources**

<http://energy.hawaii.gov/developer-investor/project-permitting-assistance-and-resources>

Provides numerous resources to support more informed and appropriate project siting and permitting, including the Permit Guide, Renewable Energy Permitting Consultants, DOH, ePermitting Portal, Renewable EnerGIS, Permitting Wizard, and the Renewable Energy Projects Directory.

**Hawai‘i Clean Energy Programmatic Environmental Impact Statement**

<http://energy.hawaii.gov/testbeds-initiatives/hawaii-clean-energy-peis/peis-overview>

The Hawaii Clean Energy Programmatic Environmental Impact Statement (PEIS) analyzes, at a programmatic level, the potential environmental impacts of clean energy activities and technologies in the following clean energy categories: (1) Energy Efficiency, (2) Distributed Renewables, (3) Utility-Scale Renewables, (4) Alternative Transportation Fuels and Modes, and (5) Electrical Transmission and Distribution.

**Hawai'i Statewide GIS Program**

<http://planning.hawaii.gov/gis/>

Provides Hawai'i GIS data and other resources to support site identification and analysis.

**Aloha Aina: A Framework for Biocultural Resource Management in Hawai'i's Anthropogenic Ecosystems**

[https://nmshawaiihumpbackwhale.blob.core.windows.net/hawaiihumpbackwhale-prod/media/archive/council/pdfs/aloha\\_aina.pdf](https://nmshawaiihumpbackwhale.blob.core.windows.net/hawaiihumpbackwhale-prod/media/archive/council/pdfs/aloha_aina.pdf)

A framework developed by the Hawaiian Islands Humpback Whale National Marine Sanctuary Advisory Council to integrate Native Hawaiian and Western scientific management approaches toward ecosystem management. While intended for the Sanctuary, this document provides useful insight into successful collaboration in Hawai'i.

**DRAFT**  
**REQUEST FOR PROPOSALS**  
**FOR**  
**COMMUNITY-BASED RENEWABLE ENERGY TRANCHE 1**  
**ISLAND OF O‘AHU**

DECEMBER 1, 2020

Docket No. 2015-0389

*Appendix G – Self Build Option and  
Self Build Option Team Certification Form*



**Hawaiian  
Electric**



## Appendix G - Self Build Option

### Overview

To the extent that there are Self Build Option (“SBO”) Proposals to the RFP, the Company will endeavor to evaluate these SBO Proposals on a fair basis compared to third party Proposals. As described in Section 1.9.1 of the RFP, “[t]he Competitive Bidding Framework allows the Company the option to offer a Proposal(s) in response to this RFP (“Self-Build Option” or “SBO”). Accordingly, the Company must follow certain requirements and procedures designed to safeguard against and address concerns associated with: (1) preferential treatment of the SBO or members, agents or consultants of the Company formulating the SBO (the “Self-Build Team”); and (2) preferential access to proprietary information of the Self-Build Team.” Any Proposal from the Self-Build Team will be required to comply with the provisions in the Framework for Competitive Bidding (“Framework”) as well as this RFP.

In addition to its Proposal, the Self-Build Team will be required to submit Attachment 1 to this Appendix G, Self-Build Option Team Certification Form, acknowledging it has followed the rules and requirements of the RFP to the best of its ability and has not engaged in any collusive actions or received any preferential treatment or information providing an impermissible competitive advantage to the Self-Build Team over other proposers responding to this RFP, as well as adherence to PPA or Mid-Tier SFC terms and milestones required of all proposers and the SBO’s proposed cost protection measures.

Pursuant to the Framework and as set forth in the RFP Schedule, the Company will require that the Proposal for the SBO(s) be submitted electronically through the Electronic Procurement Platform a minimum of one (1) Day before other Proposals are due.

Except where specifically noted, a SBO Proposal must adhere to the same price and non-price Proposal requirements as required of all Proposers.

As described in Section 3.8.4 of the RFP, if selected, a Self-Build Proposer will not be required to enter into a PPA or Mid-Tier SFC with the Company. However, the SBO will be held to the same performance metrics and milestones set forth in the RDG PPA or Mid-Tier SFC to the same extent as all Proposers, as attested to in the SBO’s Appendix G Attachment 1 Self Build Option Certification submittal. If liquidated damages are assessed, they will be paid from shareholder funds and returned to customers through the Purchased Power Adjustment Clause (“PPAC”),

In lieu of price components, the SBO will need to provide their total project capital costs, any associated annual O&M costs, as well as annual revenue requirements by year. (See Appendix B Section 2.0.) The SBO shall submit revenue requirement worksheets with their Proposal that support their annual revenue requirements estimates. A starter revenue requirements template file can be requested by the Self-Build Team via email to the RFP Email Address or through the PowerAdvocate Messaging function once the RFP event opens. The revenue requirements

worksheets submitted will be customized to reflect the details of the Project's Proposal. All assumptions used will be reflected in an assumptions input tab.

### **SBO Total Project Capital Cost**

The following is a high-level breakdown followed by a narrative explanation of the total capital cost estimate for a potential SBO Proposal. The total project capital cost (and annual O&M costs) will be used to calculate the Revenue Requirement, which will then be used to calculate a LB for Proposal comparison purposes. The categories of costs include:

- Facility
  - EPC Contract
  - Allowance for Change Orders
  - Equipment
  - Owner's Cost
- Outside Services
- Interconnection
- Overheads
- AFUDC

These costs will be identified in Section 2.3.2.2 of the SBO Proposal. (See Appendix B Section 2.3.2.2.)

- Facility (including any generation and storage components) - This line item, to the extent applicable, should include costs such as:

#### Engineering, Procurement, and Construction ("EPC") Contract

The total cost estimate of the facility is the projected EPC contract cost including the design of the facility up to the high-voltage terminals of the step-up transformers, procurement of all the equipment, and services necessary to build the facility and construction and commissioning of the facility.

#### Allowance for Change Orders

This allocation accounts for items such as additional requirements resulting from unforeseen conditions, unexpected permitting requirements, force majeure events, unanticipated interferences, different interpretations of design requirements, material unavailability, and longer than normal delivery times.

#### Equipment

This cost includes the generator and the facility equipment that support the operation of the generator and the distribution of electrical power around the station, as applicable. Engineering and testing services required to ensure that the equipment is properly functioning at the site, training and documentation necessary to operate and maintain the equipment, and performance guarantees may also be included here.

### Owner's Cost

Owner's costs for the facility are all the costs necessary for the design, permitting, procurement, construction, and commissioning of the facility and for the preparation of the Proposal that are not included in the major contracts (i.e. EPC). The Companies' Labor includes Project Management, Station Operator training and commissioning, Environmental, Safety, Legal, Corporate Communications, Community and Government Relations, Engineering, and Regulatory Affairs. Company Labor for the preparation of the Proposal is also included here. For purposes of recovery, only the incremental costs of Labor will be subject to separate recovery.

- Outside Services - This line item, to the extent applicable, should include costs such as:
  - Construction Management to oversee the EPC contractor
  - Legal for the preparation of the Environmental Impact Statement and PUC process
  - Engineering for development and evaluation of the project technical specifications, Interconnection Requirements Study (IRS), and emissions testing
  - Environmental to conduct the Environmental Impact Statement (EIS) and Air Permit consulting
  - General Services such as surveys, land appraisals, Environmental Condition Reports, public relations, office trailer rental, archeological services, landscaping, miscellaneous permits, builder's risk insurance, switchgear testing, hazard analysis, painting, monitoring services, and moving costs.
  - Material costs including spare parts, furnishings, IT equipment, appliances, generator system initial fills (fuels, oils, water), and telecommunications equipment for the station.
  - Travel costs required to inspect other similar facilities, observe final acceptance testing of critical equipment, and station operators' factory training
- Interconnection – This line item covers all interconnection costs that a similarly situated IPP would be responsible for as described in RFP Section 2.3.5, and to the extent applicable, should include costs such as:

### Distribution Line

The cost estimate includes the design, procurement, and construction of any new distribution infrastructure needed to interconnect with the designated substation.

### Switchyard

Work at the switchyard will include design, procurement, and construction of the switchyard and the interfaces between the high voltage terminals of the generator step-up transformers and the circuit to which it will be connected. Site preparation

of the switchyard and the design, procurement, and installation of the step-up transformers located in the switchyard, are typically included in the EPC contract.

#### Substation

Work at the designated substation that will include the design, procurement, and construction of the interfaces between the new distribution line and the substation buswork to which it will be connected.

#### Telecom

Accounts for direct labor, materials, and outside services to install telecommunication requirements for the project.

#### Project Management

Cost estimate of the project management design, procurement, contracting, and scheduling efforts for the interconnection only. Project management costs for the facility are included in the Owner's Cost estimate above.

- Overhead Costs

Overhead costs for the proposed facility will be estimated by the Company's budgeting software (UI Planner) and represent an allocation for those Company costs that are not attributable to any particular project or operation, but are essential nonetheless. Overheads are comprised of non-productive wages (such as holiday, sick, and vacation pay), employee benefits, payroll taxes, corporate administrative costs, and clearing costs.

- Allowance for Funds Used During Construction ("AFUDC")

The AFUDC will be calculated using the Company's budgeting software (UI Planner) and represents the cost of capital funding for the Project. The Company strives to minimize the cost of the AFUDC by ensuring that Project elements that are used or useful are placed in service as soon as possible, as well as minimizing the amount of time that AFUDC can accumulate, by minimizing the amount of time between expenditures on Project elements and their placement in service.

The SBO Proposal will include a Revenue Requirement for each year, which is calculated from the total project capital cost to determine the revenues needed to recover the cost of the project. The value of the Revenue Requirement Calculation for the Total SBO Project Capital Cost will be included in the Levelized Benefit calculation described below.

### **Annual O&M**

The cost for ongoing O&M (fixed and variable) will be a component of the Revenue Requirement. All O&M should be included in this category, unless captured elsewhere in the Revenue Requirement Calculation, including but not limited to annual O&M expense to maintain facility; property taxes (if applicable), and insurance. As described in RFP Appendix G, a SBO Proposal

will be required to cap its O&M costs at the amount included in the Proposal. Only actual costs will be recovered if such actual costs are lower than the maximum amounts in the Proposal.

### **Annual Revenue Requirement**

The SBO Proposal will include a Revenue Requirement for each year, which is calculated from the total project capital cost to determine the revenues needed to recover the cost of the project. The value of the Revenue Requirement Calculation for the Total SBO Project Capital Cost will be included in the Levelized Benefit calculation.

The following is a narrative description of the proposed revenue requirement calculation and significant assumptions that the SBO Proposal should account for. The objective of a revenue requirement analysis is to illustrate the annual revenue requirements (ARR) for a utility SBO Proposal.

Revenue Requirement is defined as a calculated value which represents the estimated revenues needed from ratepayers which would allow the Company to recover its capital investment and expenses, honor its debt obligations, pay its revenue and income tax liabilities, and pay its preferred shareholders while providing a fair return to its common shareholders for their investment. Specific factors or assumptions related to that particular project will be included in the analysis.

The purpose of a revenue requirement calculation is to determine the annual and total revenue requirements of a capital investment and annual O&M expense needed from customers. The ratemaking formula for revenue requirements is shown below.

$$RR = O + T + D + r(RB)$$

Where:

- RR = Revenue Requirements
- O = Operating and Maintenance Expense
- T = Tax Expense (Income and Revenue)
- D = Depreciation Expense
- r = Rate of Return on Rate Base
- RB = Rate Base

The Company, in conjunction with the Independent Observer, may also conduct a risk assessment of the SBO Proposal to ensure an appropriate level of customer cost protection measures are included in such proposal.

**APPENDIX G ATTACHMENT 1 - SELF BUILD OPTION TEAM CERTIFICATION**

**Name of SBO Team Contact:** \_\_\_\_\_

**Unique Name of Facility:** \_\_\_\_\_

This Certification of the Self Build Option (SBO) Team's SBO Proposal for Hawaiian Electric Company, Inc.'s ("Company, Maui Electric Company, Ltd., and Hawai'i Electric Light Company, Inc.'s (the "Hawaiian Electric Companies")) Request for Proposals for Community-Based Renewable Energy Projects (RFP) is made as of the date stated below.

**A. COMPLIANCE WITH THE RFP AND CODE OF CONDUCT**

The SBO Team certifies and acknowledges that it will/has:

1. Adhered to the terms of the RFP applicable to the SBO Team, including but not limited to: Section 1.7.1 (proposal submittal requirements) , Section 1.7.3 (certification of non-collusion), Section 1.9 (Procedures for the Self-Build or Affiliate Proposals), and Section 3.4.4 (authorized signatory);
2. Adhered to the technical requirements of the RFP, excluding however those requirements inapplicable to the SBO Team such as execution of the Model RDG PPA or Mid-Tier SFC, pricing formula requirements for independent power producer proposals, submission of a Proposal Fee, dispute resolution, credit requirements, selection of a priority list, and submission of a best and final offer;
3. Complied with the Company's Code of Conduct Procedures Manual, attached as Appendix C to this RFP, with particular attention to the Communications Protocols described in Section C therein with respect to communication with the Company RFP Team.

**B. INDEPENDENT INVESTIGATION**

The SBO Team further certifies and acknowledges that it will/has:

1. Submitted the SBO Proposal based on its own investigations, examinations, and determinations, including assessments of any risks that could have an effect on its obligations under the SBO Proposal.
2. Carefully examined the Company's RFP documents and its appendices and has a clear and comprehensive knowledge of what is required of a Proposer under the RFP, and correspondingly, what is required of the SBO Team.

3. Examined and understands the technical requirements, schedule, and evaluation process as it is laid out in the RFP.

**C. COST PROPOSAL ACKNOWLEDGEMENTS**

The Self Build Team acknowledges and agrees that:

1. Recovery for Project capital costs and O&M costs will be capped at the amount included in the SBO Team's SBO Proposal.
2. Only actual capital costs and O&M costs will be recovered even if such actual costs are lower than the SBO Team's proposed maximum amounts.
3. Costs of developing the proposal must be included in the SBO for evaluation purposes only. Only the incremental costs of developing the SBO Team's proposal will be charged to the project and passed through to customers. Incremental costs for the SBO Proposal not serving as the Parallel Plan and which are not selected to the Final Award Group will not be recoverable from the Companies' customers.

**D. ADHERENCE TO PPA REQUIREMENTS AND MILESTONES**

The Self Build Team acknowledges and agrees that:

1. The SBO Proposal will be consistent with the scope of work and responsibilities of the "Seller" under the terms of the applicable Model PPA or Mid-Tier SFC excluding inapplicable terms related to commercial and legal interactions between the Seller and the Company.
2. The SBO Facility will be designed and constructed to:
  - a. Achieve the Performance Standards identified in Section 3 - Performance Standards, in Attachment B of the applicable Model PPA or Mid-Tier SFC as modified by the IRS (subject to reasonable adjustment agreeable to the Company consistent with the Company's negotiation of such performance standards that would be completed with an independent power producer under similar circumstances);
  - b. Meet the performance metrics as specified in Article 2 of the applicable Model RDG PPA or Attachment C of the Mid-Tier SFC.
    - b.1. For facilities with a photovoltaic generation component, (i) PV System Equivalent Availability Factor, and (ii) Measured Performance Ratio;
    - b.2. For facilities with paired energy storage, (i) Storage Annual Equipment Availability Factor, (ii) Storage Annual Equivalent Forced Outage Factor, and (iii) Storage Capacity Ratio;
  - c. Pass the Acceptance Test specified in Attachment N – Acceptance Test General Criteria of the applicable Model RDG PPA or Attachment F of the Mid-Tier SFC.

- d. Pass the Control System Performance Test specified in Attachment O – Control System Acceptance Test Criteria of the applicable Model RDG PPA or Attachment F of the Mid-Tier SFC;
- e. If applicable, pass the On-line Performance Test specified in Attachment W – BESS Capacity Test of the applicable Model RDG PPA or Attachment H of the Mid-Tier SFC;
- f. If applicable, achieve a Demonstrated Capacity equal to or greater than that indicated in the SBO Proposal as measured pursuant to Attachment W – BESS Capacity Test of the applicable Model RDG PPA or Attachment H of the Mid-Tier SFC;
- g. Meet the project milestones identified in the SBO Proposal no later than the dates specified therein, which shall be consistent with the guaranteed project milestones required in Attachment K – Guaranteed Project Milestones of the applicable Model RDG PPA or Mid-Tier SFC (subject to reasonable adjustment agreeable to the Company consistent with the Company’s negotiation of such milestones that would be completed with an independent power producer under similar circumstances). Notice of completion of milestones and any delay will be provided to PUC and Consumer Advocate.
- h. Achieve the reporting milestones identified in the SBO Proposal no later than the dates specified therein, which shall be consistent with the reporting milestones required in Attachment L – Reporting Milestones of the applicable Model RDG PPA or Mid-Tier SFC (subject to reasonable adjustment agreeable to the Company consistent with the Company’s negotiation of such milestones that would be completed with an independent power producer under similar circumstances). Notice of completion of milestones and any delay will be provided to PUC and Consumer Advocate.
- i. Will be subject to the applicable liquidated damages for the applicable Model RDG PPA or Mid-Tier SFC provisions above. These liquidated damages would be paid from shareholder funds and would be passed through to customers through the Companies’ Power Purchase Adjustment Clause. Notice of any liquidated damages assessed and amounts of such liquidated damages will be provided to PUC and Consumer Advocate.
- j. Will reconfirm requirements in GO7 application and any resulting approval order for such application.
- k. Will provide annual report to PUC and Consumer Advocate on performance metrics.

**E. DECLARATION AND SIGNATURE**

1. The individual(s) that has (have) signed this Self Build Option Team Certification is (are) duly authorized by the SBO Team to execute such on behalf of the SBO Team; and
2. All statements, specifications, data, confirmations, and other information set out in this Self Build Option Team Certification are complete and accurate in all material respects.



IN WITNESS WHEREOF, the SBO TEAM hereby makes the certifications, acknowledgements, and agreements stated herein as of the date stated under the signature of its authorized representative:

Dated at \_\_\_\_\_, \_\_\_\_\_ this \_\_\_\_\_ day of \_\_\_\_\_ 20\_\_\_\_\_.

\_\_\_\_\_  
Signature of SBO Team Representative

\_\_\_\_\_  
Name of SBO Team Representative (please print)

\_\_\_\_\_  
Title of SBO Team Representative (please print)

**DRAFT**

**REQUEST FOR PROPOSALS**

**FOR**

**COMMUNITY-BASED RENEWABLE ENERGY**

**TRANCHE 1**

**ISLAND OF O‘AHU**

DECEMBER 1, 2020

Docket No. 2015-0389

*Appendix H – Interconnection Facilities and  
Cost Information*

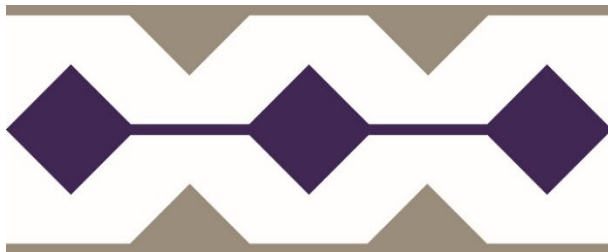

**Hawaiian  
Electric**

Hawaiian Electric Company  
APPENDIX H - INTERCONNECTION FACILITIES AND COST INFORMATION

Tariff Rule No. 19, approved by the PUC, establishes provisions for Interconnection and Transmission Upgrades (see [Appendix I](#)). The tariff provisions are intended to simplify the rules regarding who pays for, installs, owns, and operates interconnection facilities in the context of competitive bidding. Tariff Rule No. 19 will be utilized as the basis for addressing interconnection and transmission upgrades for any projects developed through this RFP. Proposers will comply with the terms and conditions as specified therein.

To assist Proposers in assessing the impacts of location on potential projects, the per unit cost figures provided in the tables below are to be used to provide an approximate estimated cost for interconnecting, including substation, telecommunications, security, and transmission or distribution line cost to the existing Hawaiian Electric System. The per-unit cost figures below should not be used to create a detailed project estimate. A detailed project estimate typically requires a certain level of engineering to assess project site conditions and to factor in other parameters specific to the project.

The Proposer should identify the components assumed for their project and the quantity assumed for each. Each table below provides notes on the assumptions for each of the unit cost estimates. If a Proposer’s project requirements are different than what is assumed in the notes, the Proposer should identify each difference and provide an estimated additional cost or savings resulting from those different requirements.

**2.1 Transmission & Distribution Line Interconnection Costs**

Please refer to [Attachment 1](#) (for Distribution Projects greater than 250 kW and less than 1 MW), [Attachment 2](#) (for Distribution Projects 1 MW or greater), or [Attachment 3](#) (for Subtransmission Projects) of this [Appendix H](#) for a single line diagram depicting the required interconnection to the Company’s system. Conceptual design is not intended to cover all interconnection requirements. Final interconnection design will be subject to the results of a technical review. The costs below are high level per unit costs for Company T&D work in support of the Project. Please see [Attachment 4](#) for examples of how to apply these per unit costs.

Component	Description	Cost
1	New 12kV Overhead line (accessible 150' spans)	\$1,356,000 / mile
2	New 12kV Overhead line (inaccessible 250' spans)	\$1,792,000 / mile
3	12kV underbuild on existing line (accessible 150' spans)	\$978,000 / mile
4	12kV underbuild on existing line (inaccessible 250' spans)	\$1,292,000 / mile
5	New 12kV Underground line	\$2,407,000 / mile
6	12kV double riser	\$48,000 each
7	12kV padmount 3ph transformer	\$97,000 each
8	12kV switchgear	\$229,000 each
9	46kV overbuild on existing 12kV line (accessible 150' spans)	\$2,026,000 / mile

Hawaiian Electric Company  
APPENDIX H - INTERCONNECTION FACILITIES AND COST INFORMATION

Component	Description	Cost
10	46kV overbuild on existing 12kV line (inaccessible 250' spans)	\$3,268,000 / mile
11	Reconductor 46kV overhead line (accessible 250' spans)	\$1,241,000 / mile
12	Reconductor 46kV overhead line (inaccessible 250' spans)	\$2,403,000 / mile
13	Developer-build 46kV overhead Base Cost (up to 500ft line extension)	\$44,000 each
14	Developer-build 46kV underground Base Cost (up to 500ft line extension)	\$72,000 each
15	Developer-build 46kV overhead Adder (each additional 100ft of extension above 500ft)	\$6,000 each
16	Developer-build 46kV underground Adder (each additional 100ft of extension above 500ft)	\$8,000 each
17	Developer-build final tap – 46kV overhead to overhead	\$38,000 each
18	Developer-build final tap – 46kV riser w/ switch (OH to UG)	\$134,000 each

**Notes:**

1. Assume 12 kV line extensions will be Company-build.
2. Assume 46 kV line extensions will be Developer-build. For Developer-build, Company will review Developer designs, inspect Developer construction, and perform the final tap at the grid connection point. Assume that Company will construct any part of the line extension that needs to be overbuilt on existing Company facilities and any reconductoring work required for the Project.
3. Components 1 and 2 assume wood pole construction.
4. Components 3 and 4 assume no poles need to be replaced.
5. Component 5 assumes two (2) sets of feeder cables.
6. Component 6 assumes a new wood pole is needed.
7. Components 7 and 8 include Company labor and materials to install Company-owned electrical facilities.
8. Components 9, 10, 11, and 12 assume all poles need to be replaced.
9. Components 13 and 14 are the base cost for a Developer-build line extension up to 500ft in length.
10. Components 15 and 16 are the adder for each additional 100ft of the Developer-build line extension (above the 500ft base length of Components 13 and 14).
11. Component 17 assumes one (1) new wood pole and one (1) span to connect to a pole installed by the Developer.
12. Component 18 assumes one (1) new wood pole and riser switch
13. EXCLUSIONS to costs provided include, but are not limited to, civil infrastructure design/construction (duct lines, MHs, equipment pads, etc.), permitting, regulatory approvals, environmental/archeological studies, survey, easements/land costs, vegetation

Hawaiian Electric Company  
 APPENDIX H - INTERCONNECTION FACILITIES AND COST INFORMATION

trimming, and clearing/grading. Proposers should conduct their own due diligence for these costs.

14. Company may share joint occupancy of poles in the project scope. As a result, there may be facilities on the poles, which are neither owned nor controlled by Company. Please contact the appropriate companies and agencies for any work and costs associated with their respective facilities.
15. All estimates are provided in 2022 dollars.

**2.2 Typical CBRE SLD Interconnection Costs (Distribution Projects 250 kW and larger, and less than 1 MW)**

Please refer to Attachment 1 of this Appendix H (for Distribution Projects greater than 250 kW and less than 1 MW). Conceptual design is not intended to cover all interconnection requirements. Final interconnection design will be subject to the results of the Detailed Evaluation, Technical Review, or an IRS.

Component	Description	Cost
1	All components in Attachment 1 except for the line extension from the project to the utility distribution circuit (see <u>Section 2.1</u> above)	\$442,000

**Notes:**

1. Costs include components on the Company side of the demarcation shown in Attachment 1.
2. Costs for line extension from the project to tap the distribution circuit should be estimated using Section 2.1, above.
3. Estimate does not contain any of the following costs:
  - a. Telecommunication infrastructure
  - b. Relay Coordination Study
  - c. Land Cost
  - d. Environmental Assessment/Environmental Impact Statement
  - e. Project Management
4. Substation relay protection requirements have not been identified, so costs are based upon typical line protection relaying requirements.
5. All estimates are provided in 2022 dollars.

Hawaiian Electric Company  
APPENDIX H - INTERCONNECTION FACILITIES AND COST INFORMATION

**2.3 Typical CBRE SLD Interconnection Costs (Distribution Projects 1 MW or greater)**

Please refer to Attachment 2 of this Appendix H (for Distribution Projects 1 MW or greater). Conceptual design is not intended to cover all interconnection requirements. Final interconnection design will be subject to the results of the Detailed Evaluation, Technical Review, or an IRS.

<b>Component</b>	<b>Description</b>	<b>Cost</b>
1	All components in <u>Attachment 2</u> except for the line extension from the project to the utility distribution circuit (see <u>Section 2.1</u> above)	\$480,000
2	Components at Company Substation including DTT and relaying requirements	\$423,000 / site

**Notes:**

1. Costs include components on the Company side of the demarcation shown in Attachment 2.
2. Costs for line extension from the project to tap the distribution circuit should be estimated using Section 2.1, above.
3. Component 2 assumes Company Substation is not SCADA enabled.
4. Estimate does not contain any of the following costs:
  - a. Telecommunication infrastructure
  - b. Relay Coordination Study
  - c. Land Cost
  - d. Environmental Assessment/Environmental Impact Statement
  - e. Project Management
5. Substation relay protection requirements have not been identified, so costs are based upon typical line protection relaying requirements.
6. All estimates are provided in 2022 dollars.

**2.4 Typical CBRE SLD Interconnection Costs (Subtransmission)**

Please refer to Attachment 3 of this Appendix H (for Subtransmission Projects). Conceptual design is not intended to cover all interconnection requirements. Final interconnection design will be subject to the results of the Detailed Evaluation, Technical Review, or an IRS.

Hawaiian Electric Company  
APPENDIX H - INTERCONNECTION FACILITIES AND COST INFORMATION

Component	Description	Cost
1	All components in <u>Attachment 3</u> except for the line extension from the project to the utility subtransmission circuit (see <u>Section 2.1</u> above)	\$529,000
2	Components at Company Substation including DTT and relaying requirements	\$471,000 / site

**Notes:**

1. Costs include components on the Company side of the demarcation shown in Attachment 3.
  - a. Assumes work at Developer site will be Developer-build. For Developer-build, Company will review Developer designs and materials to be purchased and inspect Developer construction. Assume that Company will terminate wires at RTU, program/test RTU, DFR, and other Company-owned devices, and perform final testing.
2. Costs for line extension from the project to tap the subtransmission circuit should be estimated using Section 2.1, above.
3. Component 2 assumes Company Substation is not SCADA enabled.
4. Estimate does not contain any of the following costs:
  - a. Telecommunication infrastructure
  - b. Relay Coordination Study
  - c. Land Cost
  - d. Environmental Assessment/Environmental Impact Statement
  - e. Project Management
5. Substation relay protection requirements have not been identified, so costs are based upon typical line protection relaying requirements.
6. All estimates are provided in 2022 dollars.

**2.5 Telecommunications**

Please refer to Attachment 1 (for Distribution Projects greater than 250 kW and less than 1 MW), Attachment 2 (for Distribution Projects 1 MW or greater), or Attachment 3 (for Subtransmission Projects) of this Appendix H for a single line diagram depicting the required interconnection to the Company's system. Conceptual design is not intended to cover all interconnection requirements. Final interconnection design will be subject to the results of a technical review.

Hawaiian Electric Company  
APPENDIX H - INTERCONNECTION FACILITIES AND COST INFORMATION

The communications equipment will require a communications channel(s). Some of the communications channel options include cellular, lease line, licensed radio, fiber, or microwave. The number of communication circuits (primary/backup) and type of communication circuits required will vary depending on the type/size of the project.

The costs below are high level per unit costs for communications requirements in support of the Project. Sections 2.6 and 2.7 provide scenarios of when these options may be utilized. Attachment 4 also provides examples of how to apply these per unit costs.

**2.5.1 Cellular or Lease Line Options**

Component	Description	Cost
1	Cellular or Lease line one-time and recurring costs	will vary based on 3 <sup>rd</sup> party provider
2	Communications Cabinet* with SCADA	\$114,000 / site
3	Communications Cabinet* with SCADA and Relay Protection	\$159,000 / site
4	Communications Enclosure with SCADA (proj. less than 1 MW)	\$43,000 / site

\* All projects that require communications will require facilities to store the communications equipment. An example for a communications cabinet is provided but other alternatives can be available upon request.

**Notes:**

1. Cellular or Lease Line:
  - a. Check with Company to understand the current cellular or lease line requirements.
  - b. Communication circuit requirements will be based on applications needed for the project.
  - c. Company can provide communication circuit interconnection requirements and assist with review of circuit order from the 3<sup>rd</sup> party provider as needed.
  - d. Customer to work directly with 3<sup>rd</sup> party provider if a cellular or lease line circuit is needed.
  - e. Cost will be the responsibility of the developer and to be negotiated with the 3<sup>rd</sup> party provider.
  
2. Communications Cabinet or Enclosure:
  - a. Cabinet used to support company equipment and capable of providing communications circuit for SCADA
  - b. Communications cabinet cost does not include fiber, microwave, or radio equipment or lease circuits.
  - c. Customer will provide all conduits, foundations, handholes, AC Power, grounding as required per company standards.
  - d. Cost estimates are in 2022 dollars.



Hawaiian Electric Company  
APPENDIX H - INTERCONNECTION FACILITIES AND COST INFORMATION

**2.5.2 Licensed 900 MHz Radio Option**

<b>Component</b>	<b>Description</b>	<b>Cost</b>
1	Licensed 900 MHz Radio equipment	\$140,000 / link
2	Communications Cabinet with SCADA	\$114,000 / site
3	Communications Cabinet with SCADA and Relay Protection	\$159,000 / site

**Notes:**

1. Licensed 900 MHz Radio:
  - a. This cost will be in addition to the Communication Cabinet cost. The radio equipment will be installed within the Communication Cabinet.
  - b. There is radio line-of-sight clearance between the communication endpoints.
  - c. FCC licensed 900Mhz Frequencies is available.
  - d. There is an existing structure/building with space available on the company side to mount the antenna equipment and house the radio equipment.
  - e. The customer will install a structure to mount the antenna equipment on the customer side.
    - i. Customer will provide any conduit required between the Communications Cabinet and antenna mount structure.
  - f. The cost includes 2 each antenna equipment to create a radio link.
  - g. Cost estimates are in 2022 dollars.
2. Communications Cabinet:
  - a. See notes above under 2.5.1 (Cellular or Lease Line Options).

**2.5.3 Fiber Cable Option**

<b>Component</b>	<b>Description</b>	<b>Cost</b>
1	Fiber with overbuild and new construction	\$456,000 / mile
2	Communications Cabinet with SCADA	\$114,000 / site
3	Communications Cabinet with SCADA and Relay Protection	\$159,000 / site

**Notes:**

1. Fiber Cable:
  - a. Accessible 250' average spans.
  - b. The poles are in good condition and do not need replacing.
  - c. The poles are not overloaded.
  - d. The poles and the attachments are in accordance with NESC 2002 and no work is required to upgrade the poles to current standards.
  - e. Cost estimates are in 2022 dollars.

Hawaiian Electric Company  
 APPENDIX H - INTERCONNECTION FACILITIES AND COST INFORMATION

2. Communications Cabinet:
  - a. See notes above under 2.5.1 (Cellular or Lease Line Options).

**2.5.4 Microwave Option**

Component	Description	Cost
1	Point-To-Point Microwave Link	\$697,000 / link
2	50 Foot Microwave Tower	\$612,000 / tower
3	100 Foot Microwave Tower	\$888,000 / tower
4	Communications Cabinet with SCADA	\$114,000 / site
5	Communications Cabinet with SCADA and Relay Protection	\$159,000 / site

**Notes:**

1. Microwave Link:
  - a. There is radio line-of-sight clearance between the communication endpoints.
  - b. FCC licensed microwave frequencies are available.
  - c. There are existing structures/buildings with space available on both ends to house the radio equipment.
  - d. Telecommunications grounding standards are up-to-date at both sites.
  - e. 48 V DC power with 12-hour battery backup is available.
  - f. This estimate does not include any special site-specific permit/approval activities that may be required including, but not limited to, Neighborhood Board (s), Conservation District Use Application, Environmental Assessment, Shoreline Management Area approval, biological (endangered species or habitat) surveys, and/or cultural (archeological) surveys or the cost of any migration required for approvals to be granted. Proposers should conduct their own due diligence for these costs.
  - g. Space is available at both ends to construct antenna towers or structures that are rated to survive a Saffir-Simpson category 4 hurricane.
  - h. Cost to interconnect to Hawaiian Electric’s existing communications network is not included.
  - i. Cost estimates are in 2022 dollars.
2. Microwave Tower
  - a. Example costs are provided for two tower options (50 ft or 100ft); other options may be available.
  - b. Telecommunications grounding standards are up-to-date.
  - c. This estimate does not include any special site-specific permit/approval activities that may be required including, but not limited to, Neighborhood Board (s), Conservation District Use Application, Environmental Assessment, Shoreline Management Area approval, biological (endangered species or habitat) surveys,

Hawaiian Electric Company  
APPENDIX H - INTERCONNECTION FACILITIES AND COST INFORMATION

and/or cultural (archeological) surveys or the cost of any migration required for approvals to be granted. Proposers should conduct their own due diligence for these costs.

- d. Cost estimates are in 2022 dollars.

### **2.6 Typical Telecommunications Interconnection Requirements (Distribution Projects 250 kW and larger, and less than 1 MW)**

Please refer to Attachment 1 of this Appendix H (for Distribution Projects greater than 250 kW and less than 1 MW). Conceptual design is not intended to cover all interconnection requirements. Final interconnection design will be subject to the results of the Detailed Evaluation, Technical Review, or an IRS.

Examples of communications requirements for interconnection projects in this category, which are subject to change based on project specific evaluations, technical reviews, or IRS, are:

1. Primary communications links can consist of cellular, lease line, licensed radio, fiber or microwave.
2. Back-up communications links not required.
3. Additional analog leased telephone lines are required to support revenue meters (cost for this not included in above tables).

### **2.7 Typical Telecommunications Interconnection Requirements (Projects 1 MW or greater, Distribution or Subtransmission)**

Please refer to Attachments 2 & 3 of this Appendix H (for Projects 1 MW or greater). Conceptual design is not intended to cover all interconnection requirements. Final interconnection design will be subject to the results of the Detailed Evaluation, Technical Review, or an IRS.

Examples of communications requirements for interconnection projects in this category, which are subject to change based on project specific evaluations, technical reviews, or IRS, are:

1. Primary communications links can consist of lease line, licensed radio, fiber or microwave.
2. Back-up communications links can consist of lease line, licensed radio, fiber or microwave.
3. Licensed radio is permitted for projects 3MW or smaller in size only.
4. Back-up communications links are optional for projects up to 3MW.
5. Back-up communications links are required for projects greater than 3MW.
6. Back-up communications links must be transport diverse until the “last mile” for projects greater than 10MW.

Hawaiian Electric Company  
APPENDIX H - INTERCONNECTION FACILITIES AND COST INFORMATION

7. Additional analog leased telephone lines are required to support revenue meters (cost for this not included in above tables).

## **2.8 Security System Interconnection Costs**

The Developer shall be responsible to incorporate security components and systems for **their facilities** that consider the Security Guidelines for the Electricity Sector (CIP-014-2): Physical Security, as published by the North American Electric Reliability Corporation (NERC) and that at a minimum adhere to Company's performance requirements outlined in Company's Physical Security Strategy for the following four security concepts.

- **Deter:** Deploy visible physical security measures to encourage individuals to seek other, less secure targets.
- **Detect:** Utilize state of the art physical security technologies to detect unauthorized intrusion and provide real-time alerts to monitoring personnel. Detection to include 24/7 monitoring personnel.
- **Delay:** Deploy multiple physical security countermeasures to delay an intruder's access to assets and provide time for incident assessment and appropriate response.
- **Respond:** Take immediate measures to assess, interrupt, and/or respond to the incident, including notification to Company and the use of contracted patrol personnel and/or the involvement of law enforcement assets to apprehend an intruder.

The Company's Physical Security Strategy is available upon request after execution of an NDA with the Company.

For Projects that are interconnecting at 46 kV, the Facility will need to meet Tier Two security requirements. For all other Projects, the Facility will need to meet Tier Three security requirements. These requirements will be subject to final review during the design and engineering phase. Additional information is available upon request after execution of an NDA with the Company.

Hawaiian Electric Company  
 APPENDIX H - INTERCONNECTION FACILITIES AND COST INFORMATION

Type of Facility	Tier One High Criticality	Tier Two Medium Criticality	Tier Three Lower Criticality
<b>Substation</b>	<ul style="list-style-type: none"> <li>• FLIR or Similar camera perimeter monitoring.</li> <li>• Secondary perimeter intrusion detection system.</li> <li>• Interior Video monitoring system with motion detection.</li> <li>• Gunfire detection/IP intercom public address system.</li> <li>• Electronic card access system for control &amp; microwave houses.</li> <li>• Standard 8' high security fence with 3-strand barbed wire V-top.</li> <li>• Interior mounted 4' high cattle fencing.</li> <li>• LED perimeter lighting.</li> <li>• All gates will be secured using a proprietary padlock system.</li> </ul>	<ul style="list-style-type: none"> <li>• Video monitoring system with motion detection.</li> <li>• Card access on control and microwave houses.</li> <li>• Standard 8' high security fence with 3-strand barbed wire V-top.</li> <li>• Interior mounted 4' high cattle fencing.</li> <li>• All gates will be secured using a proprietary padlock system.</li> </ul>	<ul style="list-style-type: none"> <li>• Standard 8' high security fence with 3-strand barbed wire V-top.</li> <li>• Interior mounted 4' high cattle fencing.</li> <li>• All gates will be secured using a proprietary padlock system.</li> </ul>

## 2.9 Project Management Costs

The costs below indicate additional Project Management expenses:

Component	Description	Cost
1	Distribution Projects 1 MW or greater	\$281,000
2	Subtransmission Projects 1MW or greater	\$426,000

Attachment 1

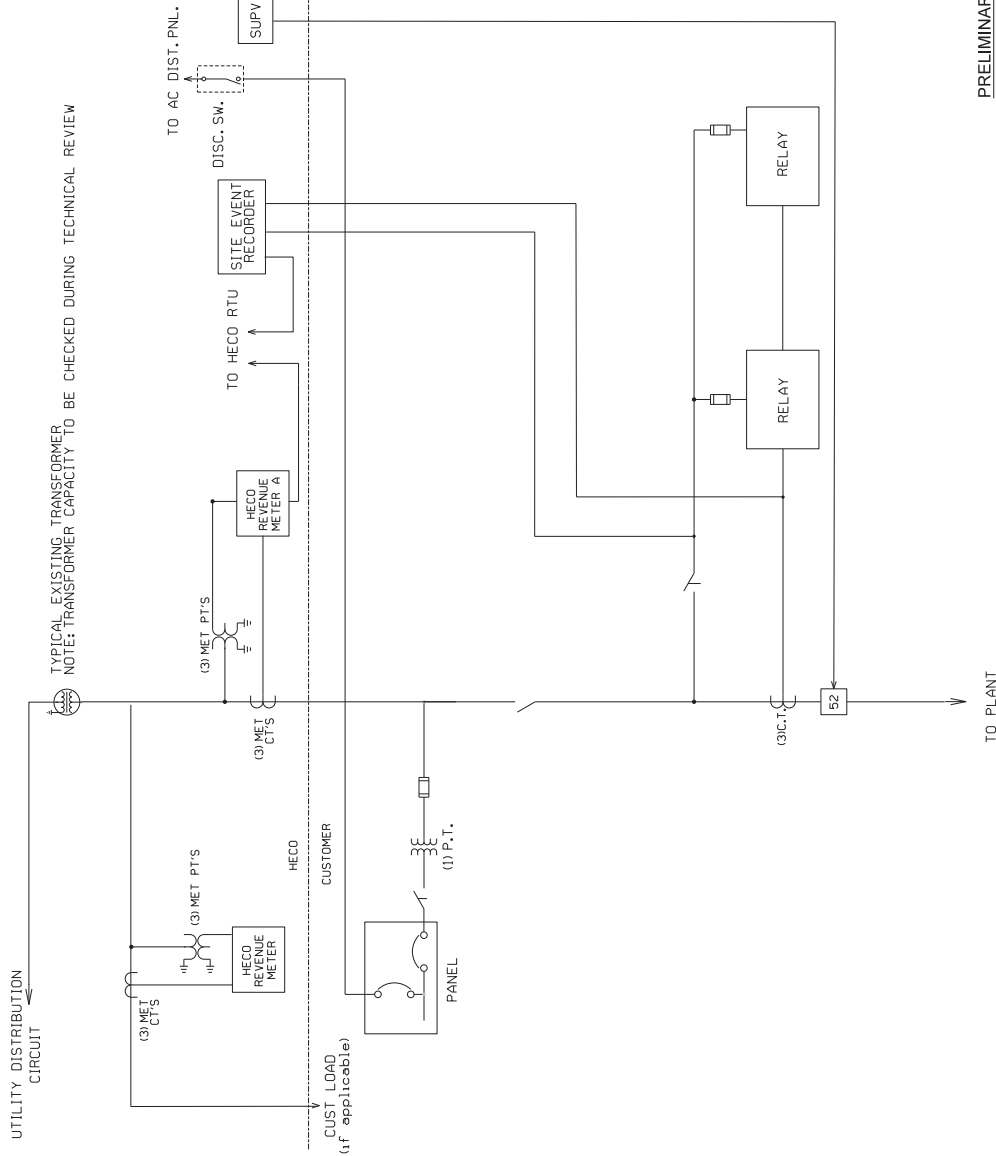

NOTES:

- 24 HOUR ACCESS:  
ALL HECO EQUIPMENT MUST BE READILY ACCESSIBLE AT ALL TIMES (24 HOURS/7 DAYS) BY HECO PERSONNEL FOR EMERGENCIES, METER READING, INSPECTION, TESTING, AND MAINTENANCE.
- ANTI-ISLANDING NOTE:  
SHALL FOLLOW REQUIREMENTS AS SET FORTH IN IEEE 1547-2018 FOR UNINTENTIONAL ISLANDING.
- FOR NEW TRANSFORMERS, TWO (2) SETS OF UNDERGROUND CABLES ARE REQUIRED TO CONNECT THE TRANSFORMER. THE LATERAL EXTENSION TO THE PROJECT SITE SHALL BE PROTECTED BY AN OVER-CURRENT PROTECTIVE DEVICE.

PRELIMINARY  
FOR INITIAL APPLICATION  
NOT TO BE USED  
FOR CONSTRUCTION  
ALSO REFER TO SLD  
DESIGN NOTES

NO.		DATE		REVISIONS		BY	CHKD	APPROV

DESIGNED	SCALE: N/A	SCALE: N/A
CHECKED	DATE: 12/23/2018	SCALE: N/A
APPROVAL	DATE: 12/23/2018	SCALE: N/A
ENGINEERING DEPARTMENT		
HAWAIIAN ELECTRIC CO., INC.		
DRAWING NUMBER		
RELAY		
0		

**Notes to be added to the Distribution (25 kV and lower) PV/BESS (250kW and larger to less than 1MW) Project Single Line Diagram**

<b>PROPOSED PROJECT NAME:</b>	
<b>PROPOSED PROJECT SIZE:</b>	
<b>CUSTOMER SLD REVISION NUMBER AND DATE:</b>	
<b>COMPANY SLD REVISION NUMBER AND DATE:</b>	
<b>COMPANY SUBSTATION:</b>	
<b>COMPANY DISTRIBUTION CIRCUIT:</b>	
<b>COMPANY DISTRIBUTION CIRCUIT BREAKER #:</b>	

**Planning Notes**

1. If IRS required, by operation procedure(s), the Project shall be paralleled with the Company system only when the \_\_\_\_\_ (Distribution circuit name) XX kV Distribution circuit is in normal operating configuration served via breaker \_\_\_\_\_ (HECO/MECO/HELCO breaker number) at \_\_\_\_\_ (Company substation name) Substation.
  
2. Customer to ensure manual closing of Customer’s main AC kV breaker CB-A (HECO/MECO/HELCO # XXXX) shall be allowed only for hot line (\_\_\_\_\_(Company Distribution circuit) XX kV line-side) and dead bus (Customer-side) unless otherwise allowed by the Company. There shall be no auto reclosing on Customer’s main AC breaker CB-A (HECO/MECO/HELCO # XXXX).

**System Operation Notes**

3. Company load dispatcher shall be enabled to issue the following to the Customer via DNP 3.0, or other Company-approved protocol interface:
  - a. Maximum Power Limit and Power Reference Limit (dispatch) set point control signals. Customer is not allowed to override Company’s curtailment control; and
  
4. The following signals provided by the Customer shall be telemetered to Company load dispatch office:
  - a. Status of Customer’s main XX kV breaker CB-A (HECO/MECO/HELCO # XXXX);
  - b. Distribution voltage (3 phase L-N);
  - c. Facility Power Possible (kW);
  - d. Facility Online/Offline Status;
  - e. Facility output (kW) that is being exported to Company System;
  - f. Facility’s confirmation of a Company control being received and value of that control as implemented.
  
5. The facility equipment should be capable of supporting, at a future date additional telemetry data requested by the Company as applicable:

Attachment 1

- a. Distribution line amps (3 phase), frequency, NET kW, NET kVAR, and NET power factor at point of interconnection. Power factor to be a calculated value;
  - b. PV kW and kVAR output;
  - c. BESS kW and kVAR output/charge;
  - d. Received kWh accumulator, sent kWh accumulator, received kVARh accumulator, Sent kVARh accumulator;
  - e. Plane of Array Solar Irradiance in Watts/m<sup>2</sup>;
  - f. kW output for each inverter;
  - g. Status for each inverter;
  - h. Facility Net Power Possible (kW);
  - i. Volt-Var curve and deadband settings;
  - j. Volt-Var Enabled/Disabled Status;
  - k. Volt-Watt curve and deadband settings;
  - l. Volt-Watt Enabled/Disabled Status;
  - m. Frequency-Watt curve and deadband settings;
  - n. Frequency-Watt Enabled/Disabled Status;
  - o. BESS State of Charge (%);
  - p. BESS Energy remaining (kWh);
  - q. kW set point for each inverter
6. The following occurrences shall initiate separate alarm to Company load dispatch office.
- a. RTU Loss of Communication;
  - b. Violation of Maximum Ramp Rate Upward (Performance Standard); and
  - c. Violation of Maximum Ramp Rate Downward (Performance Standard).
7. Company requires 24 hour access to Company-owned SCADA, communication, and Company-owned relaying and monitoring equipment.
8. Company shall own a high-speed digital fault recorder (DFR) (i.e., Tesla Lite Model) near the point of interconnection, which shall be in continuous service and on a rolling window basis monitoring sub-cycle voltages, currents and harmonics, as well as disturbance events and capable of remote interrogation following an event. Company requires 24 hour access to this equipment. Customer to provide the following hard wired inputs to Company's power quality device:
- a. Status of Customer's main AC breaker CB-A (HECO/MECO/HELCO # XXXX);
  - b. line amps (3 phase); and
  - c. line-to-line voltage (3 phase)

**Telecommunication Notes**

9. Secure and reliable communication is required for the following:
- a. Monitoring and control to/ from Customer's facility;
  - b. Revenue metering for power export and consumption readings (for 1MW facility; and



Attachment 1

- c. Phone circuits as required.
- 10. Customer to provide leased service from Hawaiian Telecom as required. Customer to coordinate with Company for details

**Metering Notes**

- 11. Customer to design revenue metering facilities in accordance with the requirements in Chapter 4 of the Company's Electric Service Installation Manual.

**Design Notes**

- 12. Customer to provide a reliable DC source for 12 hour backup period; specific voltage to be determined by Company at a later date.
- 13. Customer to provide a source of station service power for its facility that will remain available when Customer's main XX kV breaker CB-A (HECO/MECO/HELCO # XXXX) is opened and the facility is separated from Company's system.
- 14. PTs and CTs for DFR should be the same quality as the PTs and CTs for the protective relaying.
- 15. Customer to provide raw count (DNP 3.0) for analog points to Company. Customer to provide hardwired dry contact pairs for status points to Company and accept hardwired control points from Company (except for DNP control signals identified in Note 3 and DNP status points identified in Note 5g).

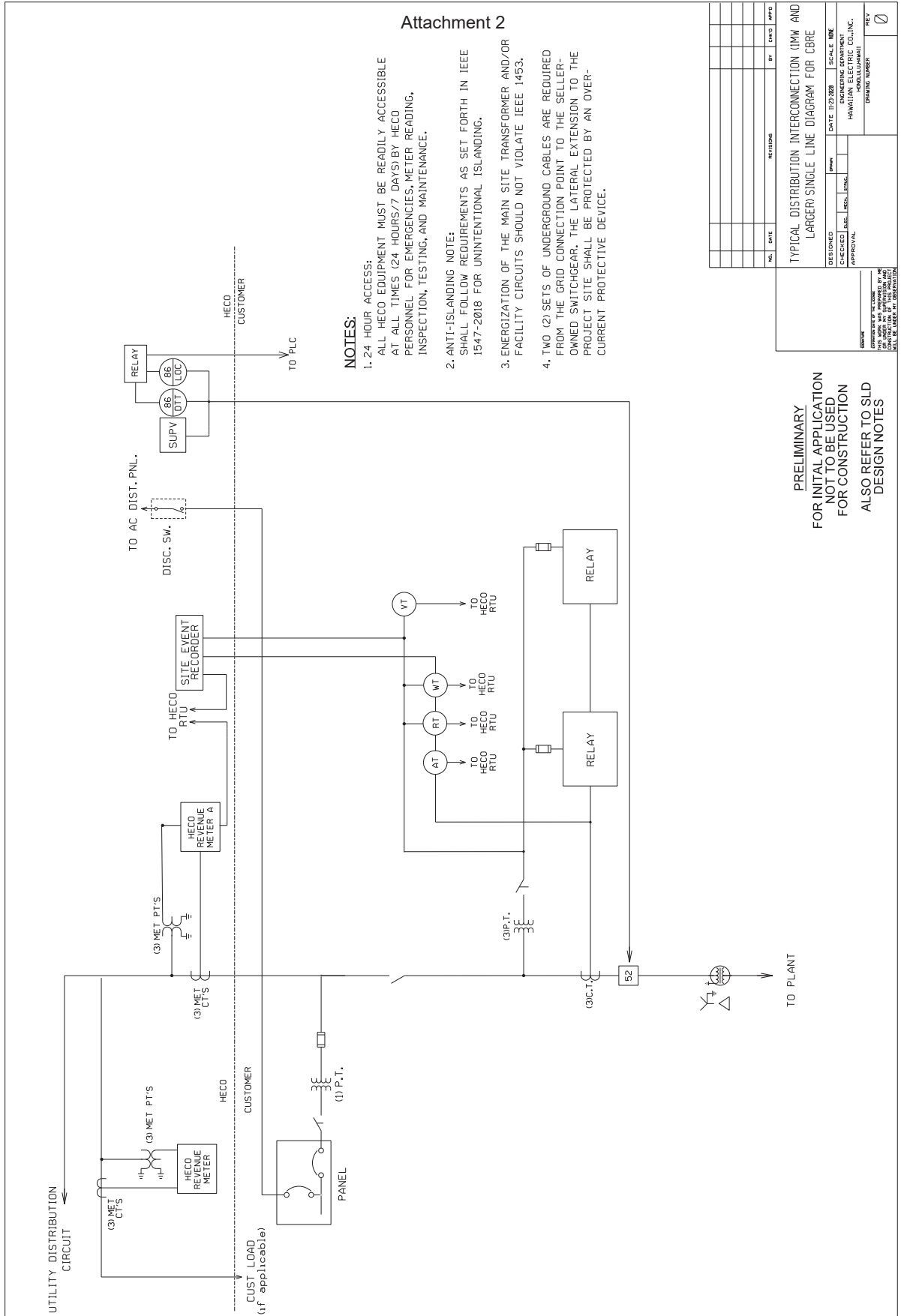

NO.	DATE	REVISION	BY	CHKD	APPRD

DESIGNED BY: DATE: 12/20/2018 SCALE: N/A  
 CHECKED BY: DATE: 12/20/2018 SCALE: N/A  
 APPROVAL: DATE: 12/20/2018 SCALE: N/A

ENGINEERING DEPARTMENT  
 HAWAIIAN ELECTRIC COMPANY  
 HONOLULU, HAWAII

DRAWING NUMBER: REV: 0

DATE: 12/20/2018  
 THIS WORK WAS PREPARED BY ME  
 OR UNDER MY CLOSE PERSONAL  
 SUPERVISION AND I AM A REGISTERED  
 PROFESSIONAL ENGINEER

**Notes to be added to the Distribution (25 kV and lower) PV/BESS (1 MW and larger) Project Single Line Diagram**

<b>PROPOSED PROJECT NAME:</b>	
<b>PROPOSED PROJECT SIZE:</b>	
<b>CUSTOMER SLD REVISION NUMBER AND DATE:</b>	
<b>COMPANY SLD REVISION NUMBER AND DATE:</b>	
<b>COMPANY SUBSTATION:</b>	
<b>COMPANY DISTRIBUTION CIRCUIT:</b>	
<b>COMPANY DISTRIBUTION CIRCUIT BREAKER #:</b>	

**Planning Notes**

1. If IRS required, by operation procedure(s), the Project shall be paralleled with the Company system only when the \_\_\_\_\_ (Distribution circuit name) XX kV Distribution circuit is in normal operating configuration served via breaker \_\_\_\_\_ (HECO/MECO/HELCO breaker number) at \_\_\_\_\_ (Company substation name) Substation.
2. Upon receipt of direct transfer trip signal from \_\_\_\_\_ (Company substation name) Substation opening of breaker \_\_\_\_\_ (HECO/MECO/HELCO breaker number), trip and block close Customer’s main XX kV breaker CB-A (HECO/MECO/HELCO # XXXX) via Company-owned SCADA resettable lockout relay.
3. Upon DTT communication channel failure longer than 6 seconds:
  - a. Company to provide signal to Customer to initiate Customer performed ramp down and tripping of Customer’s main XX kV breaker CB-A (HECO/MECO/HELCO # XXXX).
  - b. Company to initiate trip and block close of Customer’s main XX kV breaker CB-A (HECO/MECO/HELCO # XXXX) via Company-owned SCADA resettable lockout relay after \_\_\_\_\_ (Project size MW/2 MW per minute ramp down) minutes.
4. Customer to ensure manual closing of Customer’s main XX kV breaker CB-A (HECO/MECO/HELCO # XXXX) shall be allowed only for hot line (\_\_\_\_\_(Company Distribution circuit) XX kV line-side) and dead bus (Customer-side) unless otherwise allowed by the Company. There shall be no auto reclosing on Customer’s main XX kV breaker CB-A (HECO/MECO/HELCO # XXXX).

**System Operation Notes**

5. Company shall have SCADA trip control over Customer’s main XX kV breaker CB-A (HECO/MECO/HELCO # XXXX).
6. Company load dispatcher shall be enabled to issue the following to the Customer via DNP 3.0 interface:
  - a. Maximum Power Limit and Power Reference Limit (dispatch) set point control signals. Customer is not allowed to override Company’s curtailment control; and

Attachment 2

- b. Line to line Voltage (analog kV) set point control signal.
7. The following signals provided by the Customer shall be telemetered to Company load dispatch office:
- a. Status of Customer's main **XX kV** breaker CB-A (HECO/MECO/HELCO # XXXX);
  - b. Status of remotely-resettable lockouts;
  - c. Distribution line amps (3 phase), Distribution voltage (3 phase L-N), frequency, NET MW, NET MVAR, and NET power factor at point of interconnection. Power factor to be a calculated value;
  - d. Distribution line amps (B phase), Distribution voltage (A-B phase), NET MW, and NET MVAR at point of interconnection through use of Company approved non-programmable analog transducers. Data to be provided in analog format (+/- 1mA) directly from the analog transducers;
  - e. PV MW and MVAR output;
  - f. BESS MW and MVAR output/charge;
  - g. Received KWh accumulator, sent KWh accumulator, received KVARh accumulator, Sent KVARh accumulator.
  - h. Status Indicating when Maximum Power Limit is in effect;
  - i. Latest received Maximum Power Limit and Power Reference Limit Setpoints;
  - j. EMS Control Status indicating who has control over dispatch and voltage (Local vs Company);
  - k. Voltage Regulator Status – Normal or Alarm (regular On or Off)
  - l. Frequency Response Status – Normal or Alarm (On or Off);
  - m. Latest received voltage set point;
  - n. Wind speed in Miles per Hour and direction;
  - o. Barometric Pressure;
  - p. Temperature in Celsius;
  - q. Solar Irradiance in Watts/m<sup>2</sup>;
  - r. Humidity in Percent;
  - s. KW output for each inverter;
  - t. Status for each inverter (by DNP status);
  - u. Ramp Rate;
  - v. Plant Power Possible (MW);
  - w. Frequency Droop percent and deadband settings;
  - x. BESS State of Charge (%);
  - y. BESS Energy remaining (MWH);
  - z. KW set point for each inverter;
  - aa. Global Horizontal Irradiance on same axis as array (Watts/m<sup>2</sup>);
  - bb. Plane of Array Irradiance on same axis as array (Watts/m<sup>2</sup>); and
  - cc. Back of Panel temperature at array height (Celsius).
8. The following occurrences shall initiate separate alarm to Company load dispatch office.
- a. DTT and RTU Loss of Communication;

Attachment 2

- b. 48VDC and/or 125VDC Charger Trouble. Specific alarms to be determined by Company at a later date;
  - c. Trouble alarm for loss of VDC source(s); and
  - d. Operation of Company-owned SCADA re-settable lockout relays;
  - e. Violation of Maximum Ramp Rate Upward (Performance Standard); and
  - f. Violation of Maximum Ramp Rate Downward (Performance Standard).
9. Company requires 24 hour access to Company-owned SCADA/RTU, communication, and Company-owned relaying and monitoring equipment.
10. Company shall own a high-speed digital fault recorder (DFR) (i.e., Tesla Model No. 4000) near the point of interconnection, which shall be in continuous service and on a rolling window basis monitoring sub-cycle voltages, currents and harmonics, as well as disturbance events and capable of remote interrogation following an event. Company requires 24 hour access to this equipment. Customer to provide the following hard wired inputs to Company's power quality device:
- a. Status of Customer's main XX kV breaker CB-A (HECO/MECO/HELCO # XXXX);
  - b. Status of remotely-resettable lockouts;
  - c. Distribution line amps (3 phase); and
  - d. Distribution line-to-neutral voltage (3 phase)

**Telecommunication Notes**

11. For DTT communication channel failure:
- a. Signal to Customer to initiate Customer performed ramp down and tripping of Customer's main XX kV breaker CB-A (HECO/MECO/HELCO # XXXX) shall be from Company-owned SEL-2411. Company SEL-2411 signal is to be a continuous signal while communication channel is failed.
  - b. Trip and block close of Customer's main XX kV breaker CB-A (HECO/MECO/HELCO # XXXX) shall be performed by Company-owned SEL-2411 via Company-owned SCADA resettable lockout relay.
12. Secure and reliable communication is required for the following:
- a. Direct transfer trip from \_\_\_\_\_ (Company Distribution circuit) XX kV CB \_\_\_\_\_ (HECO/MECO/HELCO breaker number);
  - b. SCADA to/ from Customer's facility;
  - c. Optional back-up SCADA to/from Customer's facility;
  - d. Revenue metering for power export and consumption readings;
  - e. Power quality and fault recording and retrieval; and
  - f. Phone circuits as required.
13. Customer to provide leased service from Hawaiian Telecom as required. Customer to coordinate with Company for details.

Attachment 2

14. All DTT or SCADA loss of comm greater than or equal to 6 seconds shall cause the site to ramp down and trip (applies to both primary and backup).

**Metering Notes**

15. Customer to design revenue metering facilities in accordance with the requirements in Chapter 4 of the Company's Electric Service Installation Manual.

**Design Notes**

16. Customer to provide a reliable DC Source for 12 hour backup period; specific voltage to be determined by Company at a later date.
17. Customer to provide a source of station service power for its facility that will remain available when Customer's main XX kV breaker CB-A (HECO/MECO/HELCO # XXXX) is opened and the facility is separated from Company's system.
18. PTs and CTs for DFR and RTU transducers should be the same quality as the PTs and CTs for the protective relaying.
19. Customer to provide raw count (DNP 3.0) for analog points to Company (except as identified in Note 8d). Customer to provide hardwired dry contact pairs for status points to Company and accept hardwired control points from Company (except for DNP control signals identified in Note 8 and DNP status points identified in Note 8t).

Attachment 3

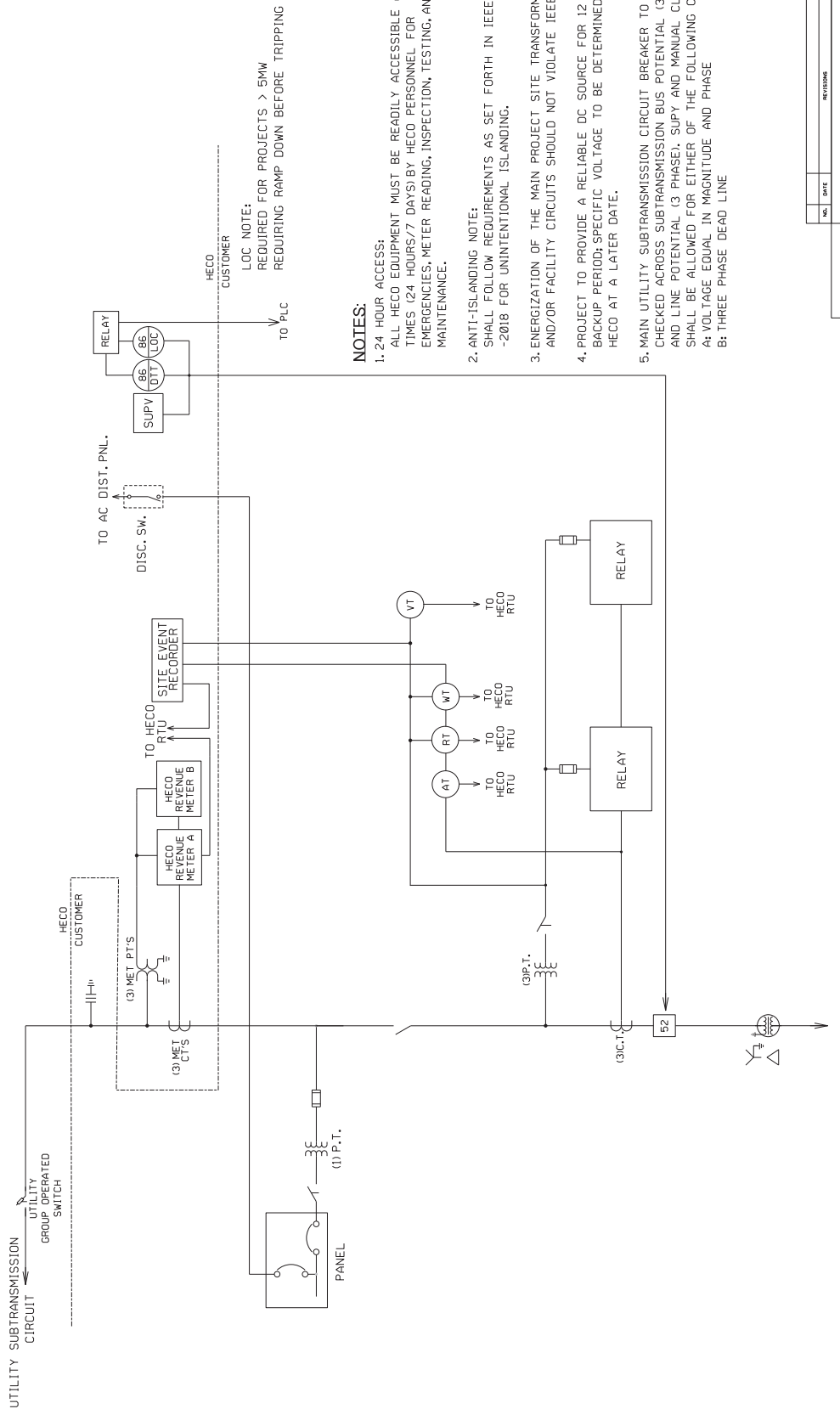

NOTES:

1. 24 HOUR ACCESS:  
 ALL HECO EQUIPMENT MUST BE READILY ACCESSIBLE AT ALL TIMES (24 HOURS/7 DAYS) BY HECO PERSONNEL FOR EMERGENCIES. METER READING, INSPECTION, TESTING, AND MAINTENANCE.
2. ANTI-ISLANDING NOTE:  
 SHALL FOLLOW REQUIREMENTS AS SET FORTH IN IEEE 1547 -2018 FOR UNINTENTIONAL ISLANDING.
3. ENERGIZATION OF THE MAIN PROJECT SITE TRANSFORMER AND/OR FACILITY CIRCUITS SHOULD NOT VIOLATE IEEE 1453.
4. PROJECT TO PROVIDE A RELIABLE DC SOURCE FOR 12 HOUR BACKUP PERIOD; SPECIFIC VOLTAGE TO BE DETERMINED BY HECO AT A LATER DATE.
5. MAIN UTILITY SUBTRANSMISSION CIRCUIT BREAKER TO BE SYNC CHECKED ACROSS SUBTRANSMISSION BUS POTENTIAL (3 PHASE) AND LINE POTENTIAL (3 PHASE), SUPY AND MANUAL CLOSING SHALL BE ALLOWED FOR EITHER OF THE FOLLOWING CONDITIONS:  
 A: VOLTAGE EQUAL IN MAGNITUDE AND PHASE  
 B: THREE PHASE DEAD LINE

HECO CUSTOMER  
 LOC NOTE:  
 REQUIRED FOR PROJECTS > 5MW  
 REQUIRING RAMP DOWN BEFORE TRIPPING  
 TO PLC

PRELIMINARY  
 FOR INITIAL APPLICATION  
 NOT TO BE USED  
 FOR CONSTRUCTION  
 ALSO REFER TO SLD  
 DESIGN NOTES

REVISIONS			
NO.	DATE	BY	APPD.
TYPICAL SUBTRANSMISSION INTERCONNECT SINGLE LINE DIAGRAM FOR CBRE			
DESIGNED	DATE 12-28-2020	SCALE 1/8" = 1'	SCALE 1/8" = 1'
CHECKED		ENGINEERING DEPARTMENT HAWAIIAN ELECTRIC CO., INC.	
APPROVAL		DRAWING NUMBER	RELY 0

**Notes to be added to the 46kV PV/BESS Project Single Line Diagram**

<b>PROPOSED PROJECT NAME:</b>	
<b>PROPOSED PROJECT SIZE:</b>	
<b>CUSTOMER SLD REVISION NUMBER AND DATE:</b>	
<b>HECO SLD REVISION NUMBER AND DATE:</b>	
<b>HECO SUBSTATION:</b>	
<b>HECO 46kV CIRCUIT:</b>	
<b>HECO 46kV CIRCUIT BREAKER #:</b>	

**Planning Notes**

1. By operation procedure(s), the Project shall be paralleled with the HECO system only when the \_\_\_\_\_ (46kV circuit name) 46 kV circuit is in normal operating configuration served via breaker \_\_\_\_\_ (HECO breaker number) at \_\_\_\_\_ (HECO substation name) Substation.
2. Upon receipt of direct transfer trip signal from \_\_\_\_\_ (HECO substation name) Substation opening of breaker \_\_\_\_\_ (HECO breaker number), trip and block close Customer's 46 kV breaker CB-A (HECO# XXXX) via HECO-owned SCADA resettable lockout relay.
3. Upon DTT communication channel failure longer than 6 seconds:
  - a. HECO to provide signal to Customer to initiate Customer performed ramp down and tripping of Customer's 46 kV breaker CB-A (HECO# XXXX).
  - b. HECO to initiate trip and block close of Customer's 46 kV breaker CB-A (HECO# XXXX) via HECO-owned SCADA resettable lockout relay after \_\_\_\_\_ (Project size MW/2 MW per minute ramp down) minutes.
4. Customer to ensure manual closing of Customer's 46 kV breaker CB-A (HECO# XXXX) shall be allowed only for hot line (\_\_\_\_\_ (HECO 46kV circuit) 46 kV line-side) and dead bus (Customer-side). There shall be no auto reclosing on Customer's 46 kV breaker CB-A (HECO# XXXX).

**System Operation Notes**

5. HECO shall have SCADA trip control over Customer's 46 kV breaker CB-A (HECO# XXXX).
6. HECO load dispatcher shall be enabled to issue the following to the Customer via DNP 3.0 interface:
  - a. Maximum Power Limit and Power Reference Limit (dispatch) set point control signals. Customer is not allowed to override HECO's curtailment control; and
  - b. Line to line Voltage (analog kV) set point control signal.
7. The following signals provided by the Customer shall be telemetered to HECO load dispatch office:
  - a. Status of Customer's 46kV breaker CB-A (HECO# XXXX);



Attachment 3

- b. Status of remotely-resettable lockouts;
  - c. 46kV line amps (3 phase), 46kV voltage (3 phase L-N), frequency, NET MW, NET MVAR, and NET power factor at point of interconnection. Power factor to be a calculated value;
  - d. 46kV line amps (B phase), 46kV voltage (A-B phase), NET MW, and NET MVAR at point of interconnection through use of HECO approved non-programmable analog transducers. Data to be provided in analog format (+/- 1mA) directly from the analog transducers;
  - e. PV MW and MVAR output;
  - f. BESS MW and MVAR output/charge;
  - g. Received KWh accumulator, sent KWh accumulator, received KVARh accumulator, Sent KVARh accumulator.
  - h. Status Indicating when Maximum Power Limit is in effect;
  - i. Latest received Maximum Power Limit and Power Reference Limit Setpoints;
  - j. EMS Control Status indicating who has control over dispatch and voltage (Local vs HECO);
  - k. Voltage Regulator Status – Normal or Alarm (regular On or Off)
  - l. Frequency Response Status – Normal or Alarm (On or Off);
  - m. Latest received voltage set point;
  - n. Wind speed in Miles per Hour and direction;
  - o. Barometric Pressure;
  - p. Temperature in Celsius;
  - q. Solar Irradiance in Watts/m<sup>2</sup>;
  - r. Humidity in Percent;
  - s. KW output for each inverter;
  - t. Status for each inverter (by DNP status);
  - u. Ramp Rate;
  - v. Plant Power Possible (MW);
  - w. Frequency Droop percent and deadband settings;
  - x. BESS State of Charge (%);
  - y. BESS Energy remaining (MWH);
  - z. KW set point for each inverter;
  - aa. Global Horizontal Irradiance on same axis as array (Watts/m<sup>2</sup>);
  - bb. Plane of Array Irradiance on same axis as array (Watts/m<sup>2</sup>); and
  - cc. Back of Panel temperature at array height (Celsius).
8. The following occurrences shall initiate separate alarm to HECO load dispatch office.
- a. DTT and RTU Loss of Communication;
  - b. 48VDC and/or 125VDC Charger Trouble. Specific alarms to be determined by HECO at a later date;
  - c. Trouble alarm for loss of VDC source(s); and
  - d. Operation of HECO-owned SCADA re-settable lockout relays;
  - e. Violation of Maximum Ramp Rate Upward (Performance Standard); and
  - f. Violation of Maximum Ramp Rate Downward (Performance Standard).

Attachment 3

9. HECO requires 24 hour access to HECO-owned SCADA/RTU, communication, and HECO-owned relaying and monitoring equipment.
10. HECO shall own a high-speed digital fault recorder (DFR) (i.e., Tesla Model No. 4000) near the point of interconnection, which shall be in continuous service and on a rolling window basis monitoring sub-cycle voltages, currents and harmonics, as well as disturbance events and capable of remote interrogation following an event. HECO requires 24 hour access to this equipment. Customer to provide the following hard wired inputs to HECO's power quality device:
  - a. Status of Customer's 46kV breaker CB-A (HECO# XXXX);
  - b. Status of remotely-resettable lockouts;
  - c. 46kV line amps (3 phase); and
  - d. 46kV line-to-neutral voltage (3 phase)

**Telecommunication Notes**

11. For DTT communication channel failure:
  - a. Signal to Customer to initiate Customer performed ramp down and tripping of Customer's 46 kV breaker CB-A (HECO# XXXX) shall be from HECO-owned SEL-2411. HECO SEL-2411 signal is to be a continuous signal while communication channel is failed.
  - b. Trip and block close of Customer's 46 kV breaker CB-A (HECO# XXXX) shall be performed by HECO-owned SEL-2411 via HECO-owned SCADA resettable lockout relay.
12. Secure and reliable communication is required for the following:
  - a. Direct transfer trip from \_\_\_\_\_ (HECO 46kV circuit) 46kV CB \_\_\_\_\_ (HECO breaker number);
  - b. SCADA to/ from Customer's facility;
  - c. Back-up SCADA to/from Customer's facility;
  - d. Revenue metering for power export and consumption readings;
  - e. Power quality and fault recording and retrieval; and
  - f. Phone circuits as required.
13. Customer to provide leased service from Hawaiian Telecom as required. Customer to coordinate with HECO for details.
14. All DTT loss of comm greater than or equal to 6 seconds shall cause the site to ramp down and trip (applies to both primary and backup).

**Metering Notes**

15. Customer to design revenue metering facilities in accordance with the requirements in Chapter 6 of the HECO Electric Service Installation Manual.

**Design Notes**

RE SLD Notes by Group RevC.docx

Attachment 3

16. Customer to provide a reliable DC Source for 12 hour backup period; specific voltage to be determined by HECO at a later date.
17. Customer to provide a source of station service power for its facility that will remain available when Customer's 46 kV breaker CB-A (HECO# XXXX) is opened and the facility is separated from HECO's system.
18. PTs and CTs for DFR and RTU transducers should be the same quality as the PTs and CTs for the protective relaying.
19. Customer to provide raw count (DNP 3.0) for analog points to HECO (except as identified in Note 8d). Customer to provide hardwired dry contact pairs for status points to HECO and accept hardwired control points from HECO (except for DNP control signals identified in Note 7 and DNP status points identified in Note 8t).

**PROJECT EXAMPLES (O'AHU) - APPENDIX H UNIT COST TABLE**

Examples provided for illustrative purposes only and is not binding for actual facility costs.

Estimated costs represent Company costs charged to the Developer.

**Projects 250kW and larger and less than 1MW interconnecting to a distribution circuit****Example 1**

270kW PV system interconnecting to an existing 150KVA transformer. Transformer needs to be replaced. No utility line extension is needed. Developer's secondary cables can be terminated to new transformer. Developer site built per Attachment 1 of this Appendix H (for Projects greater than 250kW and less than 1 MW). No remote sub work since no DTT/Relay work is required for this project size. Developer to provide cellular communications with another provider. Company to install Company-owned equipment in Developer-provided communications enclosure. Developer substation needs to meet Tier 3 security requirements.

Appx H Sec	Description	Quantity	Unit	Unit Price (\$)	Total Cost (\$)
2.1-7	Padmount transformer	1	EA	\$97,000	\$97,000
2.2-1	Company work at Developer site	1	EA	\$442,000	\$442,000
2.5.1-1	Cellular line (by Developer)	1	EA	\$0	\$0
2.5.1-4	Communications Enclosure	1	EA	\$43,000	\$43,000
2.8	Tier 3 Security (by Developer)	1	EA	\$0	\$0
			<b>ESTIMATED TOTAL =</b>		<b>\$582,000</b>

**Example 2**

750kW PV system interconnecting to an existing 12kV UG circuit. The line extension includes 50ft of new 12kV underground (2 feeders). A new transformer is required. Developer to install 12kV civil infrastructure. Developer site built per Attachment 1 of this Appendix H (for Projects greater than 250kW and less than 1 MW). No remote sub work since no DTT/Relay work is required for this project size. Developer to provide a licensed radio for telecommunications. Company to install Company-owned equipment in Developer-provided communications cabinet. Developer substation needs to meet Tier 3 security requirements.

Appx H Sec	Description	Quantity	Unit	Unit Price (\$)	Total Cost (\$)
2.1-5	New 12kV UG	50	FT	\$456	\$22,794
2.1-7	Padmount transformer	1	EA	\$97,000	\$97,000
	12kV civil infrastructure (by Developer)	1	LS	\$0	\$0
2.3-1	Company work at Developer site	1	EA	\$442,000	\$442,000
2.5.2-1	Licensed Radio	1	EA	\$140,000	\$140,000
2.5.2-2	Communications Cabinet w/SCADA	1	EA	\$114,000	\$114,000
2.8	Tier 3 Security (by Developer)	1	EA	\$0	\$0
			<b>ESTIMATED TOTAL =</b>		<b>\$815,794</b>

**Projects 1MW or greater interconnecting to a distribution circuit****Example 3**

3MW PV system interconnecting to an existing overhead 12kV circuit. The line extension includes underbuilding approximately 300ft of 12kV overhead lines on existing 46kV poles and 100ft of underground line (2 sets of cables). The line extension terminates at a customer-owned metering switchgear. Developer to install 12kV civil infrastructure. Developer site built per Attachment 2 of this Appendix H (for Projects 1MW or greater). Remote substation work is required at one (1) site for DTT/Relay work. Developer to install 12kV civil infrastructure. Developer to provide leased line telecommunications with another provider. Company to install Company-owned equipment in Developer-provided communications cabinet. Developer substation needs to meet Tier 3 security requirements.

Appx H Sec	Description	Quantity	Unit	Unit Price (\$)	Total Cost (\$)
2.1-3	12kV underbuild on existing line	300	FT	\$185	\$55,568
2.1-5	New 12kV UG	100	FT	\$456	\$45,587
2.1-6	12kV double riser	1	EA	\$36,000	\$36,000
	12kV civil infrastructure (by Developer)	1	LS	\$0	\$0
2.3-1	Company work at Developer site	1	EA	\$480,000	\$480,000
2.3-2	DTT/Relay	1	SITE	\$423,000	\$423,000
2.5.1-1	Leased line (by Developer)	1	EA	\$0	\$0
2.5.1-3	Communications Cabinet w/ SCADA and relay protection	1	EA	\$159,000	\$159,000
2.8	Tier 3 Security (by Developer)	1	EA	\$0	\$0
2.9-1	Project Management	1	LS	\$281,000	\$281,000
				<b>ESTIMATED TOTAL =</b>	<b>\$1,480,155</b>

**Example 4**

2MW PV system interconnecting to an existing underground 12kV circuit. The line extension includes approximately 450ft of underground cables (2 sets of cables). Company-owned switchgear required before a Developer-owned metering switchgear. The Company line extension terminates at the customer-owned metering switchgear. Developer to install 12kV civil infrastructure. Developer site built per Attachment 2 of this Appendix H (for Projects 1MW or greater). Remote substation work is required at one (1) site for DTT/Relay work. Developer to provide leased line telecommunications with another provider. Company to install Company-owned equipment in Developer-provided communications cabinet. Developer substation needs to meet Tier 3 security requirements.

Appx H Sec	Description	Quantity	Unit	Unit Price (\$)	Total Cost (\$)
2.1-5	New 12kV UG	450	FT	\$456	\$205,142
2.1-8	Switchgear	1	EA	\$229,000	\$229,000
	12kV civil infrastructure (by Developer)	1	LS	\$0	\$0
2.3-1	Company work at Developer site	1	EA	\$480,000	\$480,000
2.3-2	DTT/Relay	1	SITE	\$423,000	\$423,000

2.5.1-1	Leased line (by Developer)	1	EA	\$0	\$0
2.5.1-3	Communications Cabinet w/ SCADA and relay protection	1	EA	\$159,000	\$159,000
2.8	Tier 3 Security (by Developer)	1	EA	\$0	\$0
2.9-1	Project Management	1	LS	\$281,000	\$281,000
				<b>ESTIMATED TOTAL =</b>	<b>\$1,777,142</b>

---

**Projects interconnecting to a subtransmission circuit**

---

**Example 5**

5MW PV system interconnecting to an existing overhead 46kV circuit. The line extension includes overbuilding approximately 450ft of 46kV overhead lines above existing 12kV poles and 200ft of new 46kV overhead lines to the termination structure at the Developer substation. One (1) switch needed to disconnect the tap. The existing 46kV lines at the interconnection point does not meet the required ampacity so a section of 1000ft must be reconducted. All lines are accessible. Company will construct the reconductoring, the overbuild, and the final OH to OH tap between the overbuild and the new overhead lines. Developer to construct the new overhead lines between the termination structure and the last pole before the tap to the overbuild. Developer substation built per Attachment 3 of this Appendix H (for Subtransmission Projects). Remote substation work is required at one (1) site for DTT/Relay work. Company to install 650ft of ADSS fiber to the Developer substation and install Company-owned equipment in Developer-provided communications cabinet, back-up communications is required. Developer substation needs to meet Tier 2 security requirements.

Appx H Sec	Description	Quantity	Unit	Unit Price (\$)	Total Cost (\$)
2.1-9	46kV overbuild on existing 12kV	450	FT	\$384	\$172,670
2.1-11	Reconductor 46kV OH	1000	FT	\$235	\$235,038
2.1-13	Developer-build 46kV OH Base Cost	1	EA	\$44,000	\$44,000
2.1-17	Developer-build final tap (OH to OH)	1	EA	\$38,000	\$38,000
2.3-1	Company work at Developer substation	1	EA	\$727,000	\$727,000
2.3-2	DTT/Relay	1	SITE	\$471,000	\$471,000
2.5.3-1	Company fiber underbuild	650	FT	\$86	\$56,136
2.5.3-3	Communications Cabinet w/ SCADA and relay protection	1	EA	\$159,000	\$159,000
2.8	Tier 2 Security (by Developer)	1	EA	\$0	\$0
2.9-2	Project Management	1	LS	\$426,000	\$426,000
				<b>ESTIMATED TOTAL =</b>	<b>\$2,328,845</b>

**Example 6**

10MW PV system interconnecting to an existing overhead 46kV circuit. The line extension is Developer build. The line extension a 46kV overhead to underground riser with switch, approximately 700ft of underground lines, a riser pole back to overhead, and 50ft of new 46kV overhead lines to the termination structure at the developer substation. All lines are accessible. Company will install the new riser pole at the grid connection point, the riser switch, and the final tap to the existing lines. Developer will construct the new overhead and underground lines and terminate the underground cables to the riser switch. Developer substation built per Attachment 3 of this Appendix H (for Subtransmission Projects). Remote substation work is required at one (1) site for DTT/Relay work. Developer to install 46kV civil infrastructure. Developer to provide leased line telecommunications with another provider, back-up communications is required. Developer substation needs to meet Tier 2 security requirements.

Appx H Sec	Description	Quantity	Unit	Unit Price (\$)	Total Cost (\$)
2.1-14	Developer-build 46kV UG Base Cost	1	EA	\$72,000	\$72,000
2.1-16	Developer-build 46kV UG Adder	2	EA	\$8,000	\$16,000
2.1-15	Developer-build 46kV OH Adder	1	EA	\$6,000	\$6,000
2.1-18	Developer-build final tap (OH to UG)	1	EA	\$134,000	\$134,000
	46kV OH & UG electrical (by Developer)	1	LS	\$0	\$0
	46kV civil infrastructure (by Developer)	1	LS	\$0	\$0
2.3-1	Company work at Developer substation	1	EA	\$727,000	\$727,000
2.3-2	DTT/Relay	1	SITE	\$471,000	\$471,000
2.5.1-1	Primary Leased line (by Developer)	1	EA	\$0	\$0
2.5.1-1	Backup Leased line (by Developer)	1	EA	\$0	\$0
2.5.1-3	Communications Cabinet w/ SCADA and relay protection	1	EA	\$159,000	\$159,000
2.8	Tier 3 Security (by Developer)	1	EA	\$0	\$0
2.9-2	Project Management	1	LS	\$426,000	\$426,000
				<b>ESTIMATED TOTAL =</b>	<b>\$2,011,000</b>

**DRAFT**  
**REQUEST FOR PROPOSALS**  
**FOR**  
**COMMUNITY-BASED RENEWABLE ENERGY TRANCHE 1**  
**ISLAND OF O‘AHU**

DECEMBER 1, 2020

Docket No. 2015-0389

*Appendix I – Rule 19 Tariff*



**Hawaiian  
Electric**



## RULE NO. 19

## Interconnection and Transmission Upgrades

## A. GENERAL

## 1. Definitions

- a. "Betterment" means and includes any upgrading to a facility made solely for the benefit of and at the election of the Company, not attributable to the interconnection requirements. The Betterment includes any provisions for future expansion which cannot be charged to replacement. It also includes any related system work beyond that required for interconnection. If an existing facility is replaced with one of greater functional capacity or capability, the difference between the upgraded facility and a replacement facility of equivalent functional capacity is considered Betterment. It does not mean the substitution of a replacement facility for an existing facility, that is, an underground facility for an overhead facility, unless otherwise provided for in the RFP.

Example 1: A substation with a three breaker scheme is required to connect the Generating Facility to the grid. If the Company installs a substation with a six breaker ring bus scheme, the difference between installing a substation with a three breaker scheme and one with a six breaker scheme would be the Betterment.

Example 2: A transmission line needs to be upgraded to accommodate a new Generating Facility. The existing line is designed to withstand a 56 mph wind speed. The project includes upgrading the facilities to withstand a 100 mph wind speed. The increase in the design to the 100 mph wind speed criteria would be the Betterment.

Example 3: A transmission line needs to be upgraded to accommodate a new Generating Facility. In response to the Company's application to upgrade the line, the Commission orders that the line be placed underground. The cost difference between the overhead upgrade and the installation of the underground facilities would not be considered Betterment.

- b. "Company's Dispatch" means the Company's sole and absolute right to control, from moment to moment, through Supervisory Control, or otherwise, and in accordance with good engineering and operating practices in the electric utility industry, the rate of delivery of energy offered by the bidder to the Company.
- c. "Company's System" means the electric system owned and operated by the Company (to include any non-utility owned facilities) consisting of power plants, transmission and distribution lines, and related equipment for the production and delivery of electric power to the public.

HAWAIIAN ELECTRIC COMPANY, INC.

## RULE NO. 19 - Continued

## Interconnection and Transmission Upgrades

- d. "Distribution System" means all electrical wires, equipment, and other facilities at the distribution voltage levels (such as 25kV, 12kV, or 4kV) owned or provided by the Company, through which the Company provides electrical service to its customers.
- e. "Framework" means the Framework for Competitive Bidding dated December 8, 2006, adopted by the Commission in Docket No. 03-0372, Decision and Order No. 23121, which provides the mechanism for acquiring a future energy generation resource or a block of generation resources by the Company.
- f. "Generating Facility" means a bidder or utility-owned electrical energy generation resource that is interconnected to the Company electrical grid.
- g. "Grid Connection Point" means the point at which Interconnection Facilities connect to the Company's System, normally the Company's transmission grid. Facilities from the Generating Facility to the Grid Connection Point shall be considered Interconnection Facilities (see examples given in Attachment A). The Grid Connection Point will be identified in the IRS.
- h. "Interconnection Agreement" means a contract with the bidder that specifies the terms and conditions under which Interconnection Facilities (and, in some cases, certain System Upgrades) will be designed, installed, paid for, owned, operated and/or maintained. In some instances, such terms and conditions may be included in the PPA with a bidder, instead of in a separate Interconnection Agreement.
- i. "Interconnection Facilities" means the equipment and devices required to permit a Generating Facility to operate in parallel with and deliver electric energy to Company's System and provide reliable and safe operation of, and power quality on, the Company's System (in accordance with applicable provisions of the Commission's General Order No. 7, Company tariffs, operational practices and planning criteria), such as, but not limited to, transmission and distribution lines, transformers, switches, and circuit breakers.

Example 1: A wind farm facility constructed on a neighbor island (e.g. Molokai) that exports to the Company the energy it produces would be required to install undersea transmission lines to interconnect the Generating Facility to the Company's System. The undersea transmission lines and related facilities would be considered Interconnection Facilities.

HAWAIIAN ELECTRIC COMPANY, INC.

## RULE NO. 19 - Continued

## Interconnection and Transmission Upgrades

Example 2: A proposed Generating Facility is remotely located in a region of the island where there are no existing Transmission System facilities. In this case, if the size of the Generating Facility requires that it be tied to the existing Transmission System, the new Transmission System facilities (i.e. all electrical wires, equipment, and other facilities at the transmission voltage level) constructed from the Generating Facility to the Company's existing Transmission System facilities would be considered Interconnection Facilities.

- j. "Interconnection Requirements Study (IRS)" means a study, performed in accordance with the terms of the IRS Letter Agreement and with the applicable terms of the RFP and any resulting PPA, to identify the Interconnection Facilities, System Upgrades and other system requirements and all associated costs to integrate the proposed Generating Facility with the Company's System, and includes a detailed steady-state and a dynamic analysis. The IRS is conducted by the Company or its consultant and the bidder is responsible for the cost of conducting the IRS.
- k. "Interconnection Requirements Study Letter Agreement (IRS Letter Agreement)" means the letter agreement and any written, signed amendments thereto, between the Company and the bidder that describes the scope, schedule, and payment arrangements for the IRS.
- l. "IRP" means an electric utility's Integrated Resource Plan that has been submitted to the Commission for review and approval in the utility's IRP proceeding, in accordance with the Commission's IRP Framework.
- m. "IRP Framework" means the Commission's Framework for Integrated Resource Planning, dated May 22, 1992, as amended by In re Public Util. Comm'n, Docket No. 05-0075, Decision and Order No. 22490, filed on May 26, 2006.
- n. "Point of Interconnection" means the point of delivery of Energy and/or Capacity supplied by the bidder to the Company, where the facilities owned by the bidder interconnect with the facilities owned or to be owned by the Company. The bidder shall own and maintain the facilities from the Generating Facility to the Point of Interconnection. The Company shall own and maintain the facilities from the Point of Interconnection to the Company's System (see examples given in Attachment A). The Point of Interconnection will be identified in the IRS.
- o. "PPA" means a power purchase agreement or contract by the Company to purchase firm capacity, energy, or both.

HAWAIIAN ELECTRIC COMPANY, INC.

RULE NO. 19 - Continued

Interconnection and Transmission Upgrades

- p. "Renewable Energy Facility" means a Generating Facility that generates electricity using renewable energy as the source.
- q. "RFP" means a written request for proposal issued by the Company to solicit bids from interested third-parties, and where applicable from the Company or its affiliate, to supply a future generation resource or a block of generation resources to the Company pursuant to a competitive bidding process.
- r. "Subtransmission System" means all electrical wires, equipment, and other facilities at the subtransmission voltage levels (such as 46kV, 35kV, or 23kV) owned or provided by the Company, through which the utility provides electrical service to its customers.
- s. "Supervisory Control" means remote monitoring and/or control of a Generating Facility's power output and interrupting device status by means of a communication channel that is acceptable to the Company. For Generating Facilities intending to export power with an aggregate export capacity greater than 250kW, computerized supervisory control may be required to ensure the safety of working personnel and prompt response to system abnormalities in case of islanding of the Generating Facility. The Company shall determine the need for supervisory control based upon the results of the initial technical screening and/or IRS. Supervisory control shall include at a minimum monitoring of: (a) gross generation by the Generating Facility; (b) feedback of Watts, Vars, WattHours, current and voltage; (c) Vars furnished by the utility; and (d) status of the interrupting device. In addition, the supervisory control will allow the Company to trip the interrupting device during emergency conditions. Monitoring will be performed by system dispatchers or operators at the Company's control center.
- t. "System Benefit" means a material increase in power flow capability or in the reliability of the Company's electrical system from a system-wide perspective.
- u. "System Upgrades" means improvements made to the Company's System, other than the Interconnection Facilities, required to provide reliable and safe operation of, and power quality on, the Company's System (in accordance with applicable provisions of the Commission's General Order No. 7, Company tariffs, operational practices and planning criteria) when the Generation Facility is interconnected with the Company's System (see Attachment A). Such improvements may include, but are not limited to, new transmission or distribution lines, reconstruction or reconductoring of existing lines, circuit breakers, switches, transformers, buses, protective devices, communications, and substation equipment and facilities.

HAWAIIAN ELECTRIC COMPANY, INC.

## RULE NO. 19 - Continued

## Interconnection and Transmission Upgrades

- v. "Transmission System" means all electrical wires, equipment, and other facilities at the transmission voltage levels (such as 138kV or 69kV) owned or provided by the utility, through which the utility provides electrical service to its customers.

## 2. Application of Tariff

This Tariff shall apply to an RFP issued pursuant to the Framework and Interconnection Requirement Studies arising from the RFP process. In the event that there is a conflict between any provision of this Tariff and that of an RFP issued pursuant to the Framework and reviewed by the Commission in accordance with Sections III.B.2 and IV.B.6.e. of the Framework, the provisions of the RFP shall prevail. The terms and conditions established in a PPA arising from the RFP and approved by the Commission shall ultimately control over the requirements and terms of both this Tariff and the RFP.

## 3. Independent Observer

As established in the Framework, the duties and responsibilities of an Independent Observer (IO) include, among other duties and responsibilities, reviewing and monitoring the Company's communications, methods, and implementation of this Tariff, the RFP and related IRS processes.

## B. INTERCONNECTION STUDY PROCESS FOR COMPETITIVE BIDDING

## 1. RFP Package Data -- available to all prospective bidders.

RFP packages issued by the Company shall contain general and regional system information to provide prospective bidders with high level guidance relating to the Company's existing transmission infrastructure. For example, RFP packages may include information in the form of an island map with areas of the Transmission System identified that are at or near their loading limits to provide high level guidance to bidders on areas of the island with transmission constraints. These constraints may include "load pockets", which are load-driven transmission constraints as well as areas of generation-driven transmission constraints. Because transmission impacts are to a large extent specific to the characteristics of supply-side proposals, definitive transmission information cannot be provided in these maps. Detailed geographic maps of the transmission system may not be part of this information due to security concerns. Rather, a map of the island with areas of the map shaded to identify areas (rather than circuits) of transmission constraints, may be provided.

HAWAIIAN ELECTRIC COMPANY, INC.

## RULE NO. 19 - Continued

## Interconnection and Transmission Upgrades

In addition, the RFP shall include applicable transmission planning criteria that will be used in the determination of interconnection requirements and potential Transmission System impacts. The information in the bid package will provide bidders with information (a) that should help in the selection of the proposed project's characteristics, including project site, project size, and project mode of operation, and (b) to estimate the interconnection requirements associated with their Generating Facilities and the opportunity to reflect the costs of the interconnection requirements in their bids.

2. Information Requests During Bidding Process - available to all prospective bidders.

During the bidding process, if a prospective bidder requires clarification or additional technical or operational information pertaining to the Company's System, a written request with specific questions may be submitted to the Company in accordance with the requirements set forth in the RFP. The written request, specific questions, and written Company response will be provided to all bidders.

3. RFP Requirements and Threshold Criteria Screening - evaluation performed on all bids received

Each bid received will be reviewed to ensure that it satisfies all of the RFP and threshold criteria requirements. The Company will determine whether each bid conforms to the specified RFP requirements and meets the minimum threshold criteria. Applicable performance standards may be part of the threshold criteria. These performance standards may vary depending upon factors such as the size of the generating resource(s) being acquired in the RFP, the Company's ability to dispatch the Generating Facility, the operational status (e.g., as-available vs. firm) of the Generating Facility, and the fuel type of the Generating Facility (e.g., run-of-the-river hydro may have different performance standards from wind power).

4. High Level Evaluation -- performed on all bids that pass threshold screening in RFP process
  - a. All bids which pass the threshold screening in the RFP process will undergo a high level evaluation consistent with the requirements identified in the RFP, which will focus primarily on basic steady-state analyses (e.g., identifying thermal line impacts, voltage impacts, and any obvious "fatal flaws").

HAWAIIAN ELECTRIC COMPANY, INC.

## RULE NO. 19 - Continued

## Interconnection and Transmission Upgrades

- b. For each bid, a high level estimate of the costs of Interconnection Facilities and required System Upgrades will be developed based solely on the high level evaluation identified in Section B.4.a. of this Tariff and on unitized cost estimates (e.g., \$/mile for 138kV line, \$/transformer).
  - c. Results of the high level evaluation and high level estimate of the costs of Interconnection Facilities and required System Upgrades will be factored into the determination of which bids make the short list based on the requirements specified in the RFP.
  - d. Basic curtailment analysis of the proposed Generating Facility and related impacts to operations of existing Generating Facilities may also be factored into the determination of which bids make the short list based on the requirements specified in the RFP.
5. Full Interconnection Requirements Study - performed only on short list bids.
- a. An IRS shall be performed only for bid(s) that have met the RFP requirements, passed the threshold criteria, and made the short list, or as otherwise specified in the RFP.
  - b. An IRS would be performed either serially starting with the bid evaluated as the most competitive at the point of the evaluation process, then proceeding to the next most competitive bid on the short list or in parallel on all or some of the short list bidders simultaneously. The determination of whether or not IRS work is to be performed serially, in parallel, or a combination of the two will be based upon factors such as resource availability, number of short list bids, RFP schedule, and relative competitiveness of one bid to others, and the availability of all information and data from bidders necessary to perform the IRS work
  - c. The Company may if practicable "bundle" IRS work for multiple short list bids into a single IRS if the bids are, among other factors, technically, operationally and geographically (e.g., size, location, technology, timing, operating characteristics, etc.) identical or sufficiently similar to each other.
  - d. The results of the IRS, including identified Interconnection Facilities, System Upgrades, Point of Interconnection, and Grid Connection Point, will be provided to the bidder.
  - e. Bidders shall be responsible for incorporating the costs of their Interconnection Facilities into their bids. The RFP may provide bidders with an opportunity to revise their pricing proposals under certain circumstances. Any pricing change, if permitted under the terms of the RFP, will prompt a re-evaluation of short list bidders in the selection of the winning bid as provided for in the RFP.

HAWAIIAN ELECTRIC COMPANY, INC.

RULE NO. 19 - Continued

Interconnection and Transmission Upgrades

- f. The Company may perform the analyses included in the IRS, or the IRS or parts of the IRS may be contracted to an outside consultant specializing in such analyses for complex situations or in situations where the Company does not have available resources to conduct the analyses in a time frame agreeable to the Company.
  - g. The scope and cost of the IRS will depend on the complexity of the Company's System and Generating Facility that must be modeled, and the degree to which the Generating Facility will affect the Company's System.
  - h. The bidder will be responsible for the cost of the IRS (or such lesser amount as the Company may specify to facilitate the processing of interconnection requests for similarly situated facilities) to be performed in order to evaluate the impacts of the Generating Facility's interconnection to the Company's System.
- C. INTERCONNECTION COST AND SYSTEM UPGRADE COST ALLOCATION FOR COMPETITIVE BIDDING
1. The bidder shall be responsible for the cost of Interconnection Facilities and shall be responsible for the installation and maintenance of Interconnection Facilities from the Generating Facility to the Point of Interconnection, unless otherwise specified in the RFP.
  2. Interconnection Facilities from the Generating Facility to the Point of Interconnection shall be built by the bidder, unless the Company agrees otherwise.
  3. Interconnection Facilities from the Point of Interconnection to the Grid Connection Point shall be built by the Company and paid for by the bidder, unless the Company agrees or determines otherwise. The Company may elect to include Betterments to Interconnection Facilities from the Point of Interconnection to the Grid Connection Point, and such Betterments shall be paid for by the Company. The cost of Betterments to such Interconnection Facilities will not be considered in the bid evaluations. The bidder shall acquire the necessary land and easements for Interconnection Facilities from the Point of Interconnection to the Grid Connection Point, unless the Company agrees otherwise. Interconnection Facilities from the Point of Interconnection to the Grid Connection Point, if built by the bidder, shall be transferred to the Company upon completion, along with the necessary land rights and easements.

HAWAIIAN ELECTRIC COMPANY, INC.



## RULE NO. 19 - Continued

## Interconnection and Transmission Upgrades

4. The Company shall install and maintain the identified System Upgrades arising from the interconnection of the Generating Facility and shall be responsible for the cost of such System Upgrades.
  - a. The Company's cost for System Upgrades will be considered as a factor in the bid evaluations.
  - b. The degree to which the System Upgrades provide System Benefits and/or Betterments will be considered in the bid evaluations.
5. Standards and Interconnection Agreements
  - a. Interconnection Facilities and System Upgrades owned or to be owned by the Company shall be constructed in accordance with the Company's applicable standards and in accordance with the PPA or the Interconnection Agreement, if there is a separate Interconnection Agreement.
  - b. Generating Facilities and Interconnection Facilities owned by the bidder shall be constructed in accordance with applicable State and County code requirements and in accordance with the PPA or the Interconnection Agreement, if there is a separate Interconnection Agreement.
  - c. The bidder's Generating Facility may be interconnected and operated in parallel with the Company's System in accordance with the terms and conditions of the PPA between the Company and the bidder, and/or the terms and conditions of an Interconnection Agreement between the Company and the bidder, if there is a separate Interconnection Agreement.
  - d. The bidder will be required to furnish, install, operate, and maintain suitable and sufficient equipment, to maintain adequate records, and to follow such operating procedures, as may be specified by the Company to protect the Company's System from damage resulting from the parallel operation of the Seller's Facility, including the equipment, records and operating procedures more fully described in the PPA and/or Interconnection Agreement, if there is a separate Interconnection Agreement.
  - e. Interconnection Facilities shall be designed, installed operated and maintained in accordance with good interconnection practice. The objectives of good interconnection practice include, but are not limited to,
    1. Safety - To protect the safety of utility personnel, utility customers, and the public.

HAWAIIAN ELECTRIC COMPANY, INC.

## RULE NO. 19 - Continued

## Interconnection and Transmission Upgrades

2. Reliability - To maintain the reliability of the utility system for all utility customers.
  3. Power Quality - To provide for acceptable power quality and voltage regulation on the utility system and for all utility customers.
  4. Restoration - To facilitate restoration of power on the utility system.
  5. Protect Utility and Customer Equipment - To protect utility and customer equipment during steady state and faulted system operating conditions.
  6. Protect Generating Facilities - To protect generating facilities from operation of utility protective and voltage regulation equipment.
  7. Utility System Overcurrent Devices - To maintain proper operation of the utility system's overcurrent protection equipment.
  8. Utility System Operating Efficiency - To ensure operation at appropriate power factors and minimize system losses.
- f. The bidder shall obtain, at its expense, any and all authorizations, approvals, permits, and licenses required for the construction and operation of its Generating Facility and the interconnection of its Generating Facility with the Company's System, including but not limited to environmental permits, building permits, rights of way, or easements.
  - g. Where any Company-owned Interconnection Facilities are to be located on the site of the bidder's Generating Facility, the bidder shall provide, at no expense to the Company, a location and access acceptable to the Company for all such facilities.
6. Renewable Energy Facilities
    - a. In its IRP process, the Company may propose System Upgrades, to be paid for, owned and maintained by the utility, to encourage the development of Renewable Energy Facilities.
    - b. In its IRP process, the Company may propose to pay for Interconnection Facilities between the Point of Interconnection and the Grid Connection Point, in order to encourage the development of Renewable Energy Facilities.

HAWAIIAN ELECTRIC COMPANY, INC.

RULE NO. 19 - Continued

Interconnection and Transmission Upgrades

Attachment A

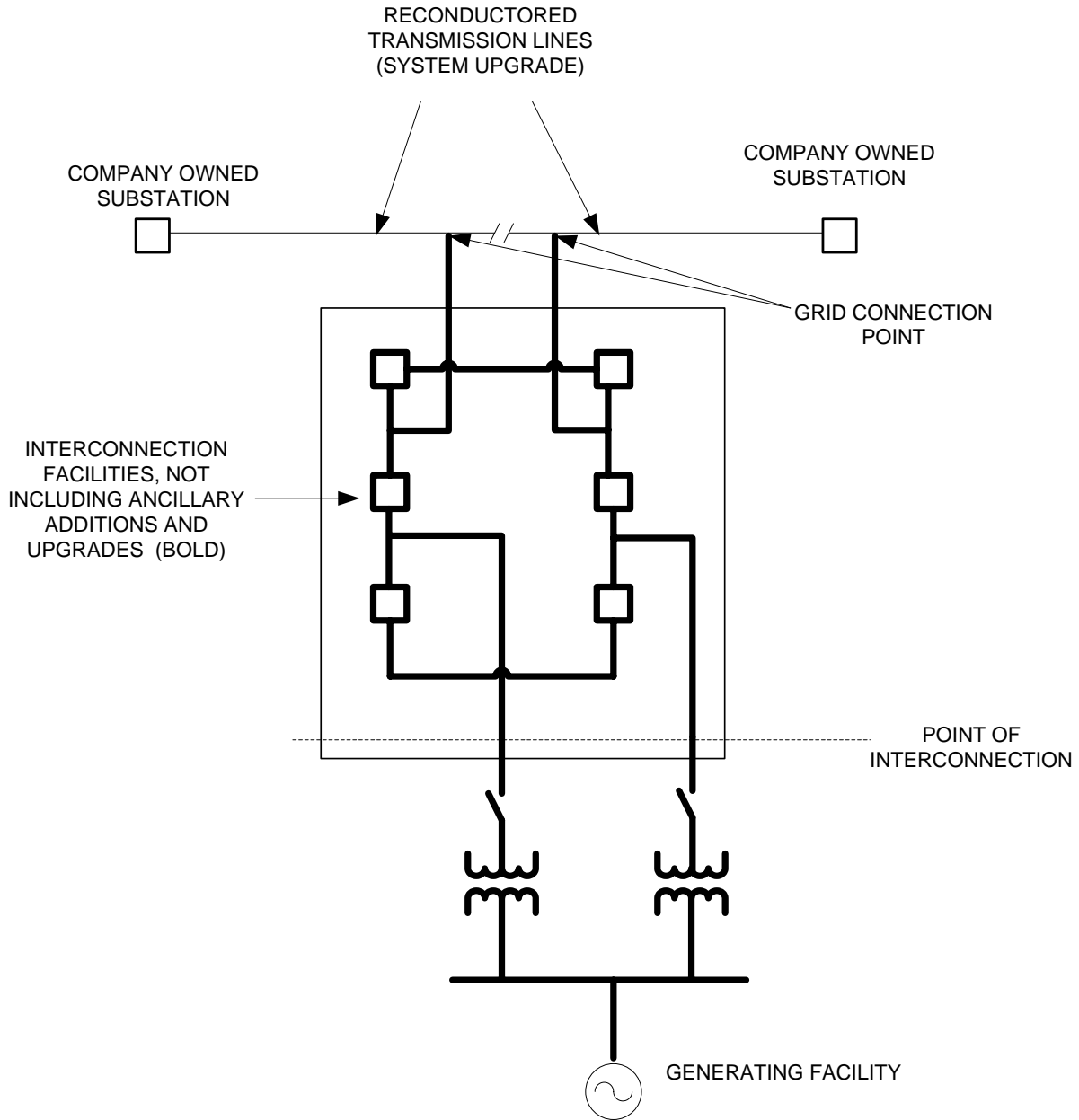

HAWAIIAN ELECTRIC COMPANY, INC.

**DRAFT**

**REQUEST FOR PROPOSALS**

**FOR**

**COMMUNITY-BASED RENEWABLE ENERGY TRANCHE 1**

**ISLAND OF O‘AHU**

DECEMBER 1, 2020

Docket No. 2015-0389

*Appendix J – Rule 29 Tariff*

**[NOTE: Please refer to Exhibit 2 of the September 8, 2020 filing for the proposed Hawaiian Electric Rule No. 29 CBRE Phase 2 as updated in Exhibit 2 of this December 1, 2020 filing.]**



**Hawaiian  
Electric**

**DRAFT**  
**REQUEST FOR PROPOSALS**  
**FOR**  
**COMMUNITY-BASED RENEWABLE ENERGY TRANCHE 1**

**ISLAND OF O‘AHU**

DECEMBER 1, 2020

Docket No. 2015-0389

*Appendix K – Model PV Large RDG PPA*

**[NOTE: Please refer to Exhibit 13 of the December 1, 2020 filing for the proposed Model PV Large RDG PPA.]**



**Hawaiian  
Electric**

**DRAFT**  
**REQUEST FOR PROPOSALS**  
**FOR**  
**COMMUNITY-BASED RENEWABLE ENERGY TRANCHE 1**

**ISLAND OF O‘AHU**

DECEMBER 1, 2020

Docket No. 2015-0389

*Appendix L – Model PV Mid-Tier Standard Form  
Contract RDG PPA (250kW to 5 MW)*

**[NOTE: Please refer to Exhibit 9 of the December 1, 2020 filing for the proposed Model PV Mid-Tier Standard Form Contract RDG PPA.]**



**Hawaiian  
Electric**

**DRAFT**  
**REQUEST FOR PROPOSALS**  
**FOR**  
**COMMUNITY-BASED RENEWABLE ENERGY TRANCHE 1**  
**ISLAND OF O‘AHU**

DECEMBER 1, 2020

Docket No. 2015-0389

*Appendix M – Model Wind Large RDG PPA*

**[NOTE: Please refer to Exhibit 15 of the December 1, 2020 filing for the proposed Model Wind Large RDG PPA.]**



**Hawaiian  
Electric**

**DRAFT**

**REQUEST FOR PROPOSALS**

**FOR**

**COMMUNITY-BASED RENEWABLE ENERGY TRANCHE 1**

**ISLAND OF O‘AHU**

DECEMBER 1, 2020

Docket No. 2015-0389

*Appendix N – Model Wind Mid-Tier Standard Form  
Contract RDG PPA (250kW to 5 MW)*

**[NOTE: Please refer to Exhibit 11 of the December 1, 2020 filing for the proposed Model Wind Mid-Tier Standard Form Contract RDG PPA.]**



**Hawaiian  
Electric**



**DRAFT**  
**REQUEST FOR PROPOSALS**  
**FOR**  
**COMMUNITY-BASED RENEWABLE ENERGY TRANCHE 1**  
**ISLAND OF O‘AHU**

DECEMBER 1, 2020

Docket No. 2015-0389

*Appendix O – Grid Needs Assessment*



**Hawaiian  
Electric**

This Appendix provides the definitions for the grid services considered in the CBRE RFPs and placeholder charts for the grid needs and their relative values. The grid services were defined as part of the Integrated Grid Planning (“IGP”) Solution Evaluation & Optimization Working Group (“SEOWG”) activities. Bidders may use the information provided in this Appendix to understand the grid needs in order to structure their proposals to provide the most value to the Company.

Grid Service Definitions

The following grid services are used to identify the grid needs. The projected hourly annual energy potential production profile of the Facility for the provided RFP NEP Projection will be used to inform the capability of the project to provide each of the grid services.

Table 1 Grid Service Definitions

<b>Grid Service</b>	<b>Definition</b>
Energy	A continuous, controllable, and predictable supply of megawatt-hours to serve system load needs in response to Company Dispatch. <sup>1</sup>
Regulating Reserves	A reserve capacity provided by generating and load resources to allow continuous energy balance over the next 1 minute and 20 to 30-minute time interval due to the variability in renewable resources and load that can be called upon in response to Company Dispatch
Fast Frequency Response (FFR1)	An autonomous and predictable capacity to limit the frequency drop resulting from a frequency disturbance
Distribution Capacity	A supply and/or a load modifying service that DERs provide as required via the dispatch of power output for generators and electric storage, and/or reduction in load that is capable of reliably and consistently reducing net loading on desired distribution infrastructure in response to Company Dispatch
Distribution Reliability	A load modifying or supply service capable of improving local distribution reliability under abnormal conditions in response to Company Dispatch

Grid Needs

---

<sup>1</sup> “Company Dispatch” as defined in the PPA and SFC means Company's right, through supervisory equipment or otherwise, to direct or control both the capacity and the energy output of the Facility from its minimum output rating to its maximum output rating consistent with this Agreement (including, without limitation, Good Engineering and Operating Practices and the requirements set forth in Section 3 (Performance Standards) of Attachment B (Facility Owned by Subscriber Organization to this Agreement)), which dispatch shall include real power, reactive power, voltage, frequency, the determination to cycle a unit off-line or to restart a unit, the droop control setting, the ramp rate setting, and other characteristics of such electric energy output whose parameters are normally controlled or accounted for in a utility dispatching system.

The charts below describe the seasonal and annual hourly need for the services in Table 1.

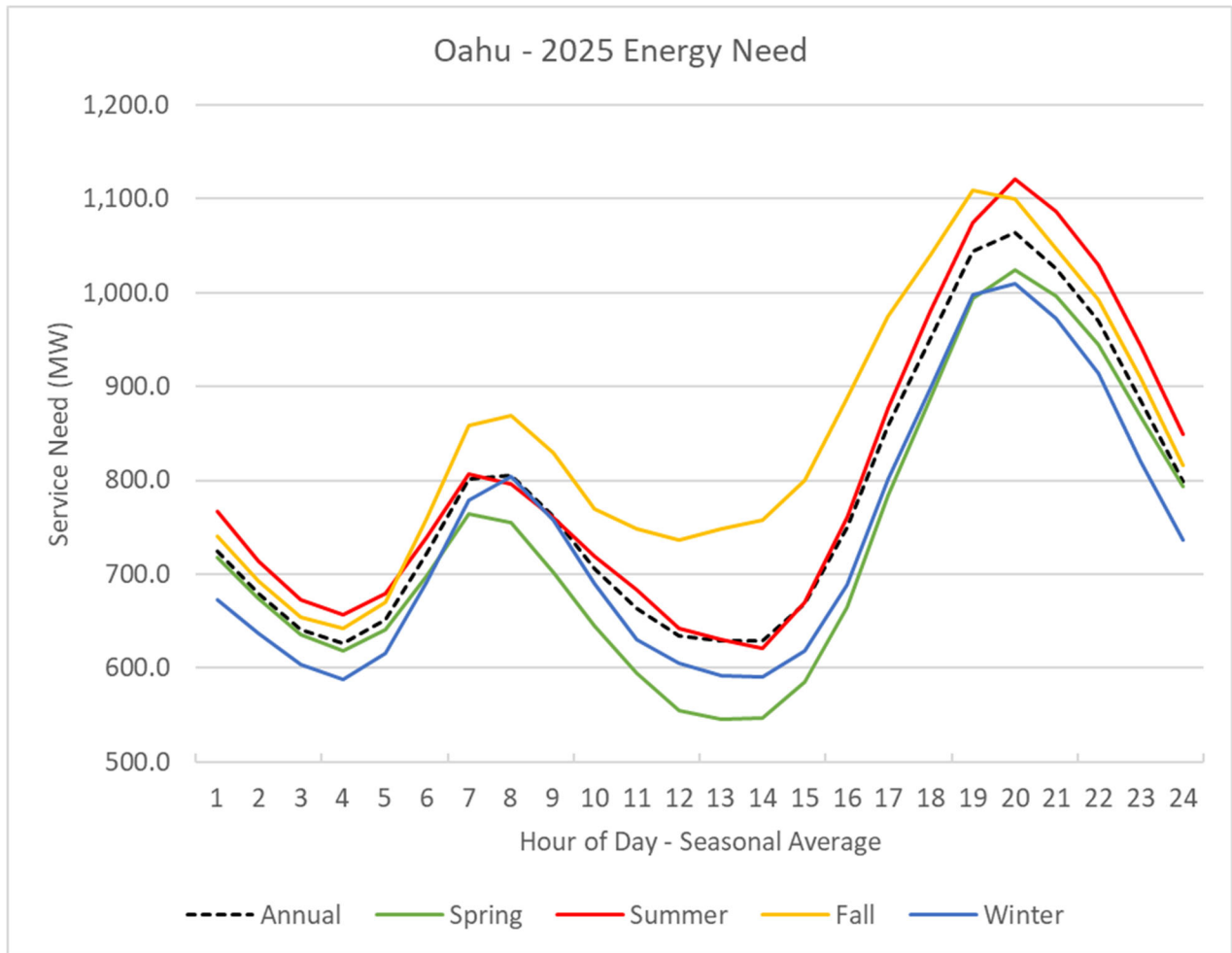

Figure 1: O‘ahu 2025 Need for Energy

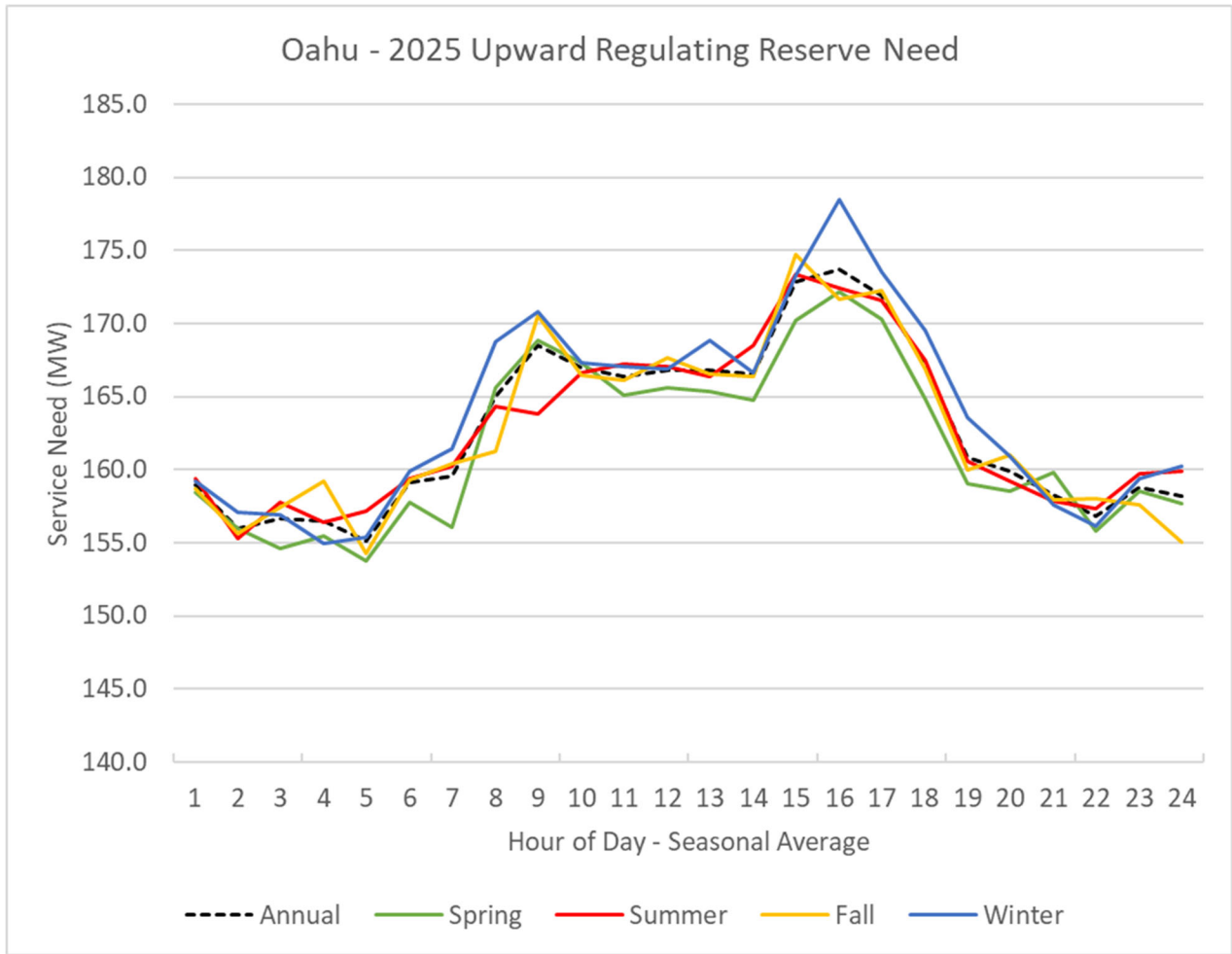

Figure 2: O'ahu 2025 Need for Upward Regulating Reserve

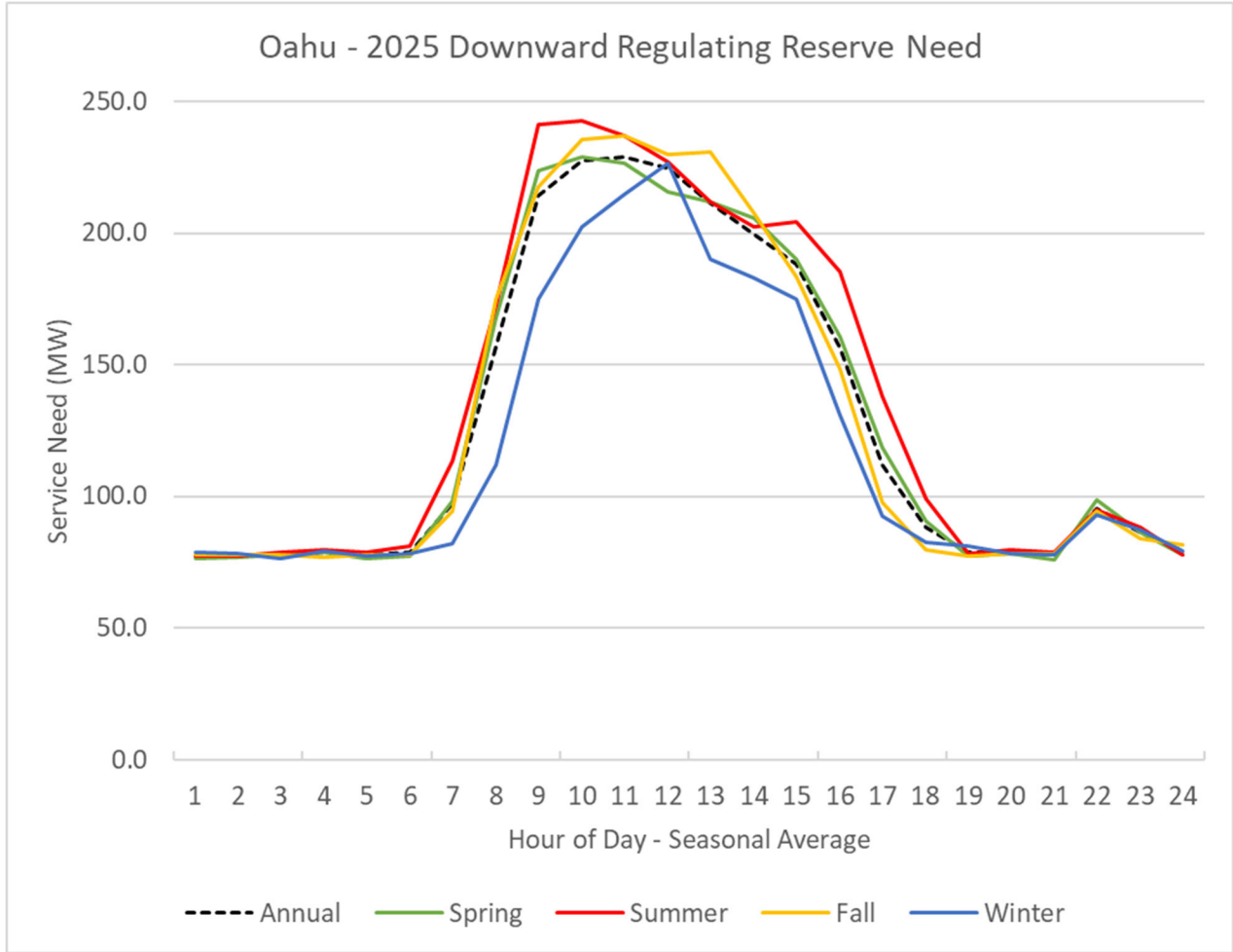

Figure 3: O'ahu 2025 Need for Downward Regulating Reserve

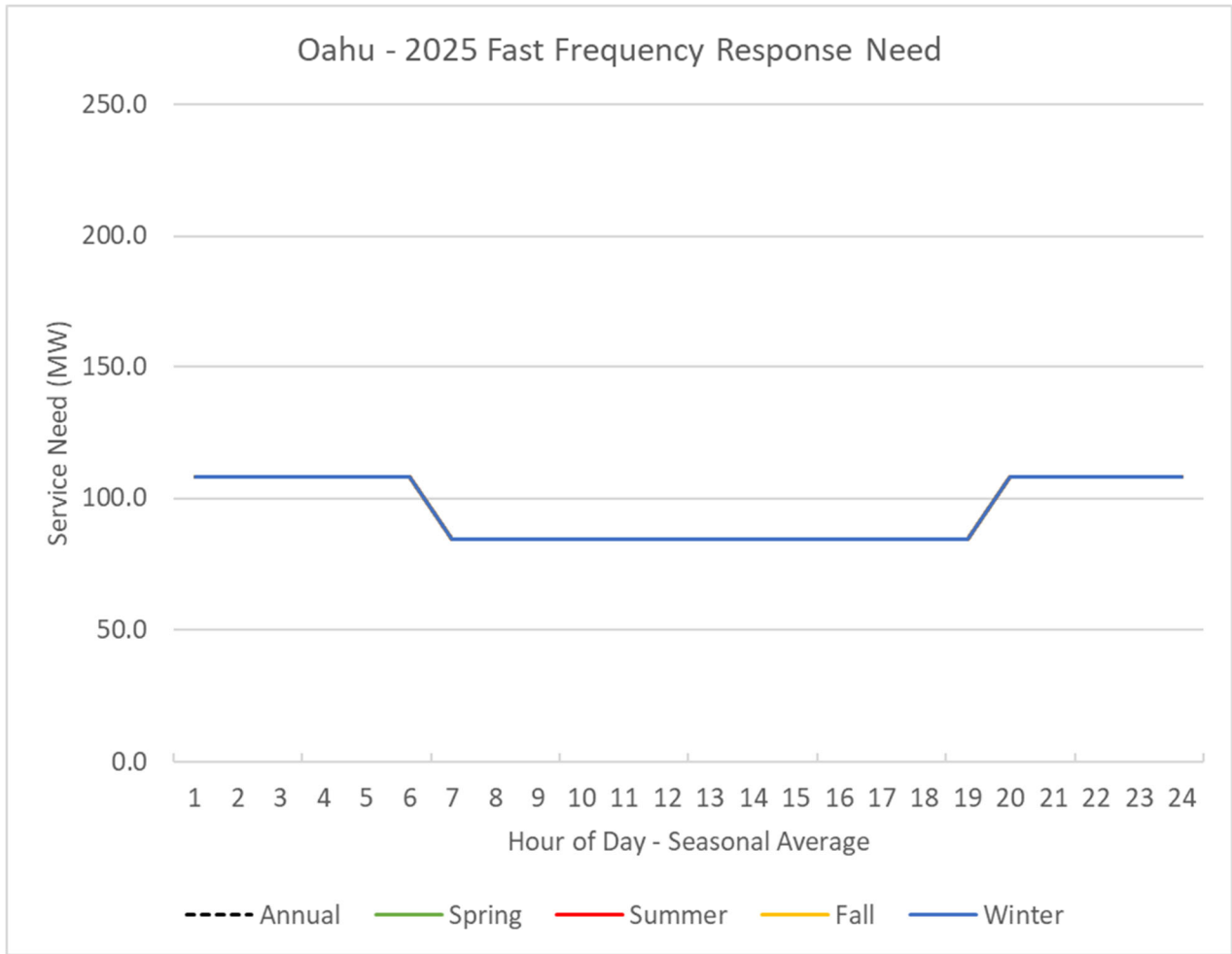

Figure 4: O’ahu 2025 Need for Fast Frequency Response

Grid Service Values

The charts below provide the relative marginal avoided costs for the grid services provided in Table 1.

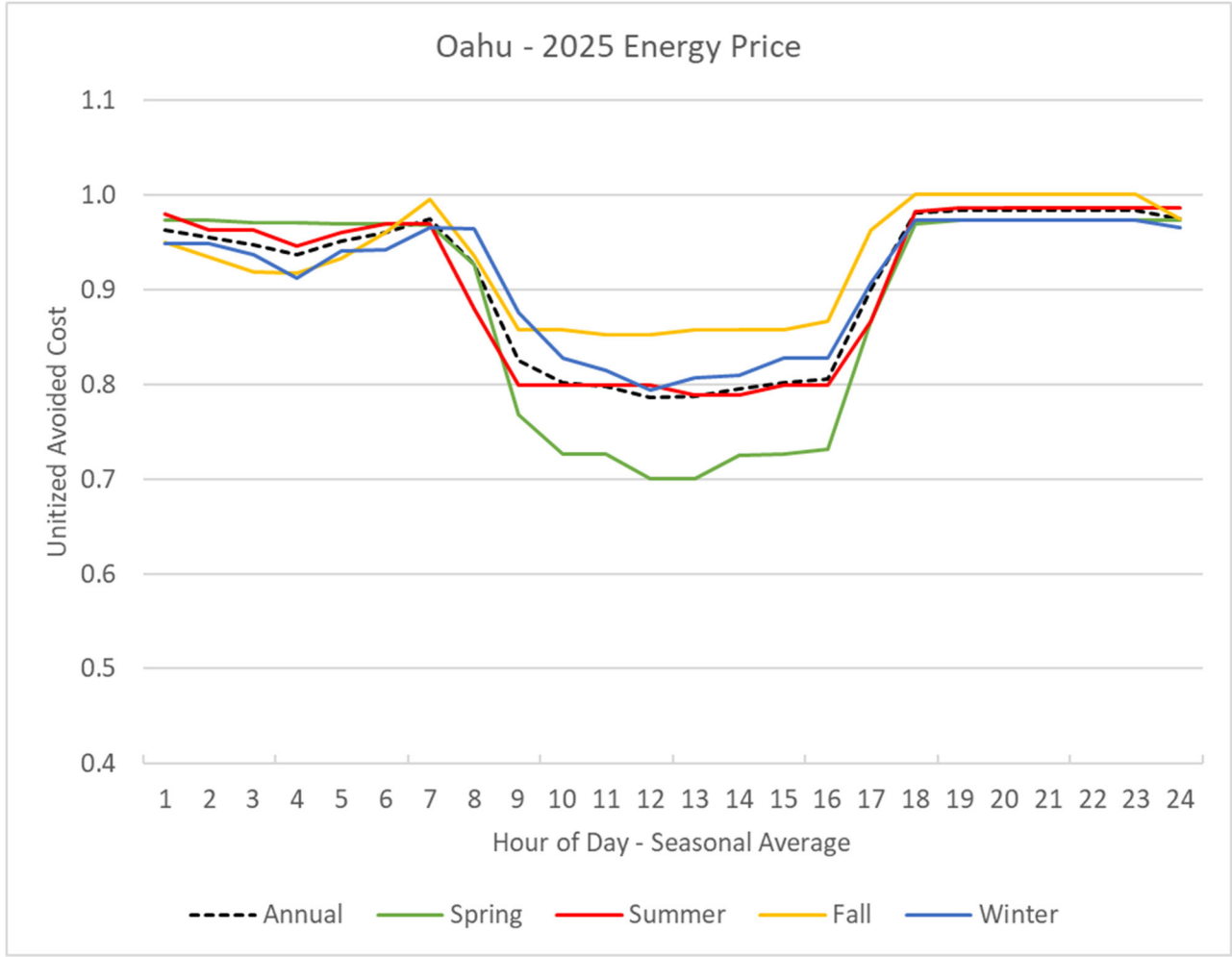

Figure 5: O'ahu 2025 Price for Energy

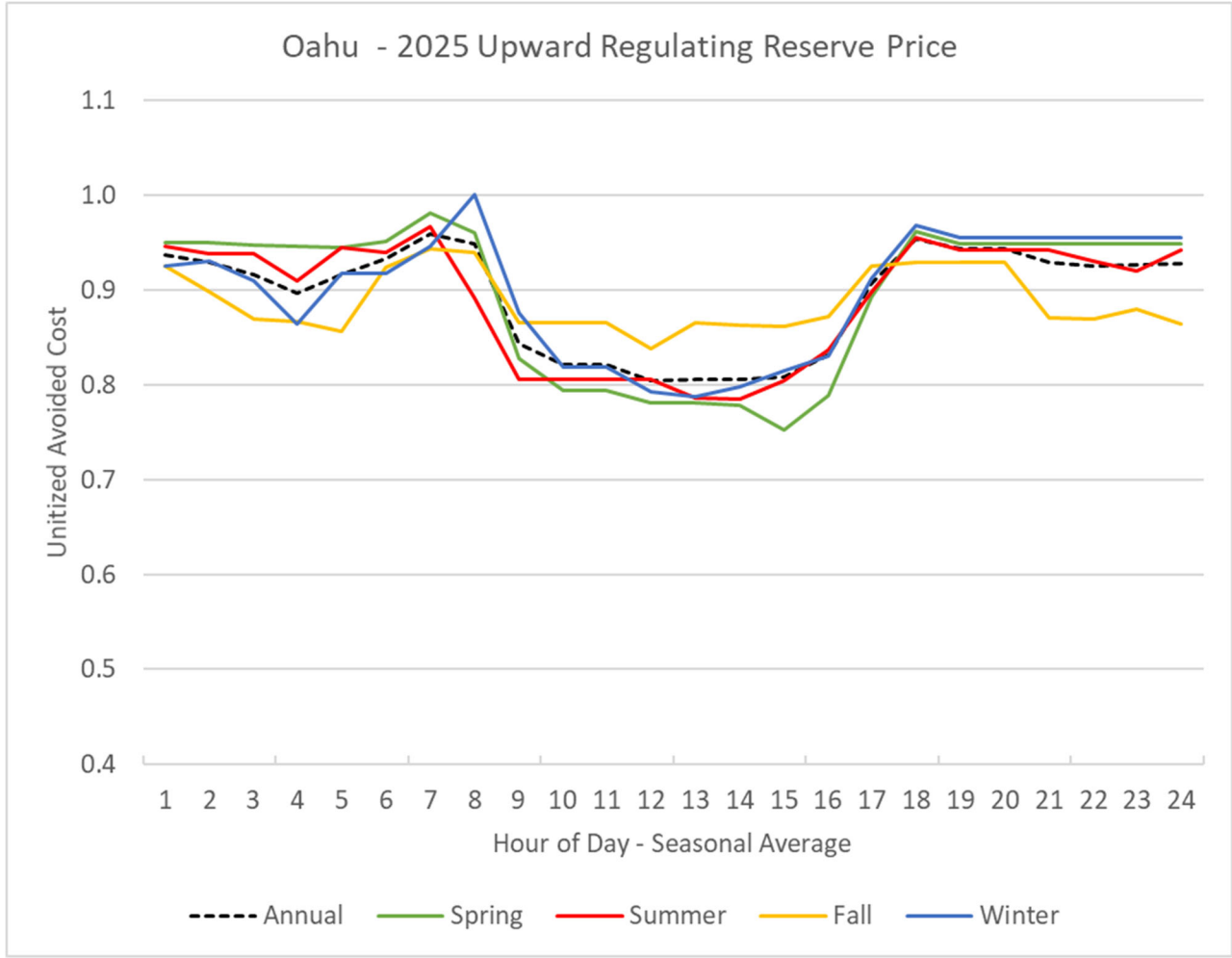

Figure 6: O'ahu 2025 Price for Upward Regulating Reserve



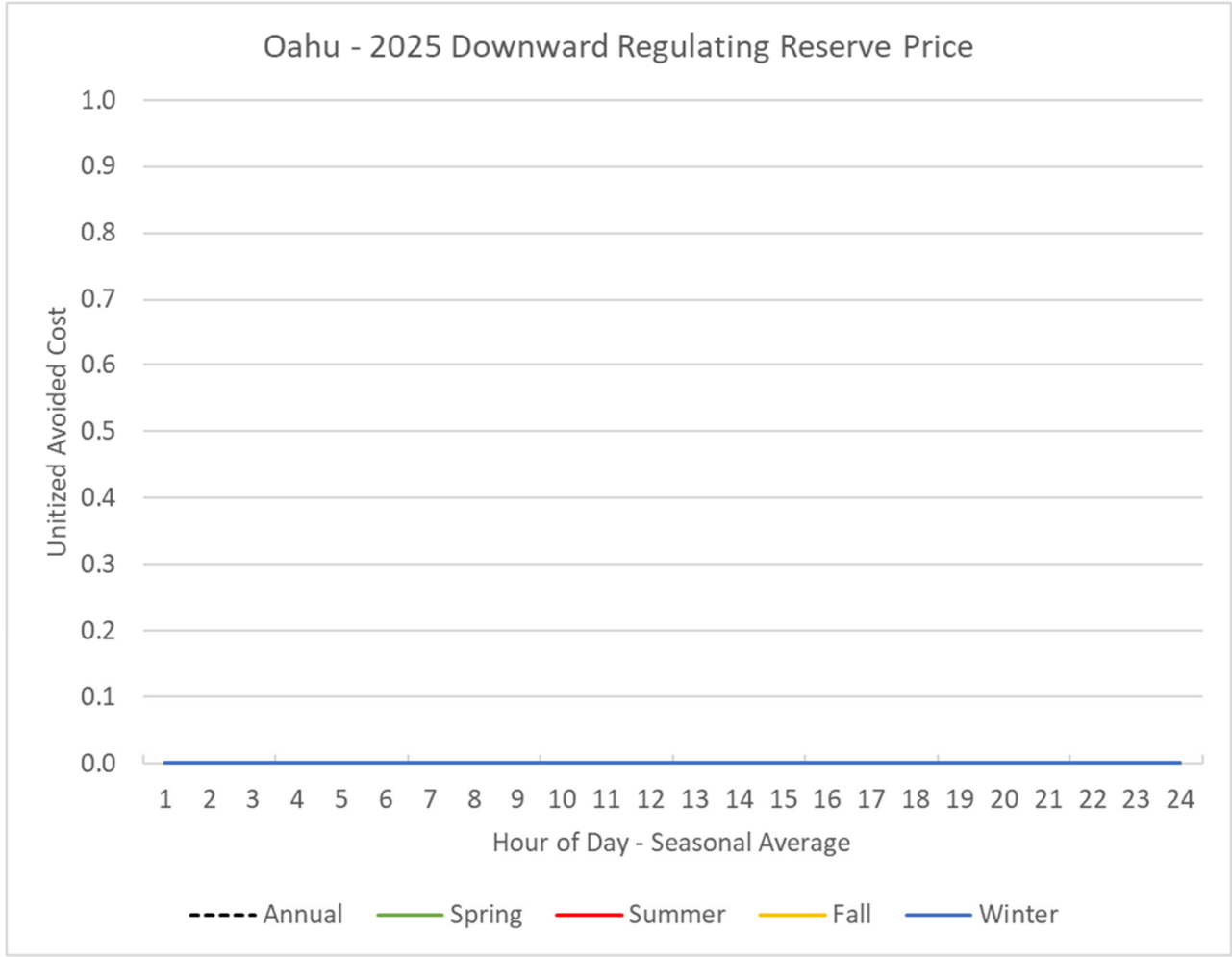

Figure 7: O'ahu 2025 Price for Downward Regulating Reserve

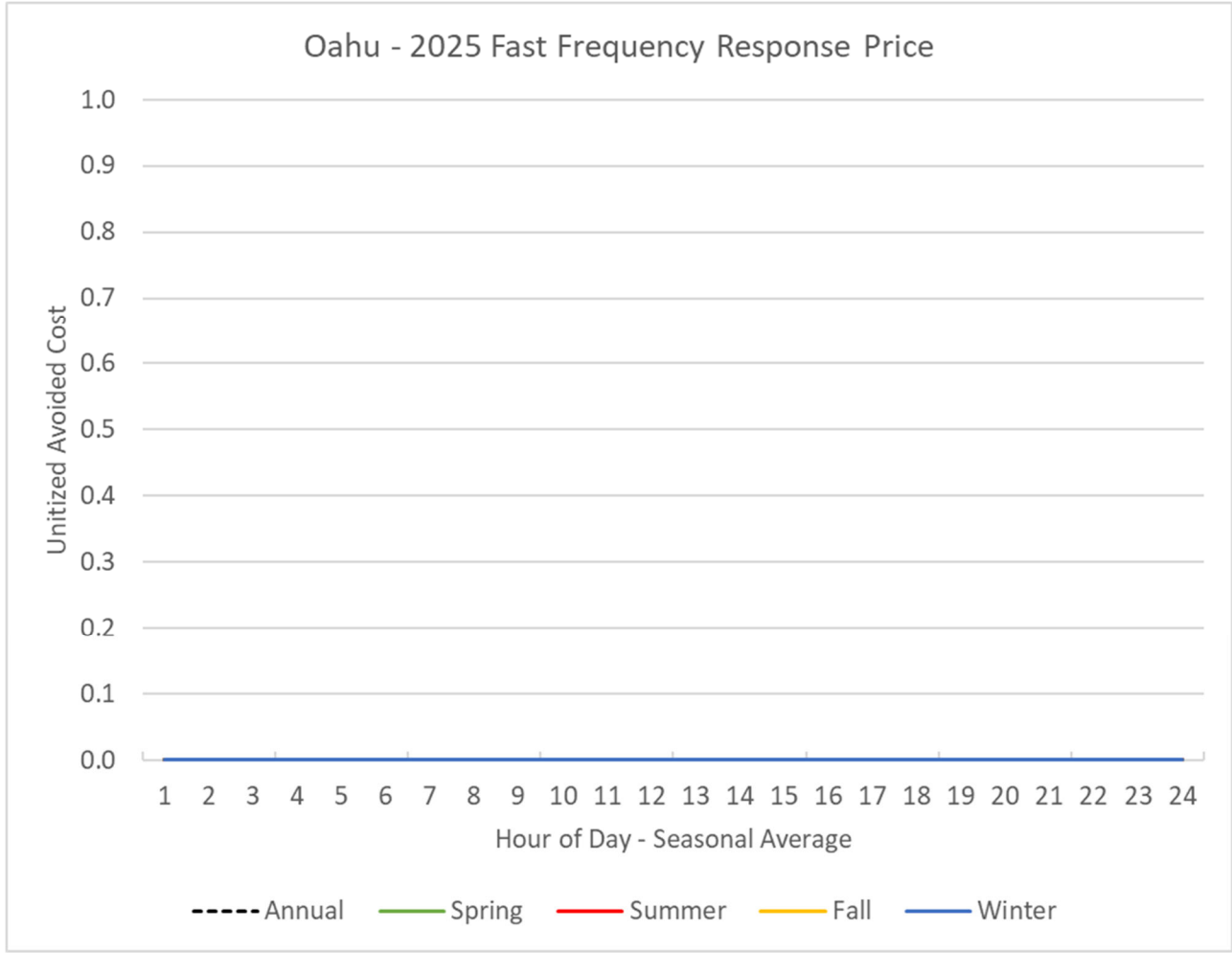

Figure 8: O'ahu 2025 Price for Fast Frequency Response

For NWA needs, the distribution avoided cost will be based on the deferral value of the capital project to be deferred for projects offering to meet that service by siting a project on a circuit with distribution grid needs with a certainty rating of 1. A certainty rating of “1” means that there is an existing need; need identified within 3 years (could be due to “natural” load growth or specific new service requests); or a need identified within 4-5 years due to a new service request.<sup>2</sup> A certainty rating of “0” means all other situations where a need may be identified. A geographic map of these needs can be found on the Company’s LVM (locational value map).

Need or Distribution Service	Year of Need	Location	MW Need	Time of Day	Certainty Rating	LVM Grid Need Name
Distribution Capacity or Distribution Reliability (back-tie)	202X	Circuits/Transformer	Size of overload (or load increase that caused voltage issue)	Daytime or Evening	1 or 0	Grid Need Name
Both	2022: Contingency 2023: Normal	CEIP 46 46 kV Circuit <sup>(a)</sup>	27.8	Evening	1	Grid Need Oahu - A
Both	2022: Normal 2023: Contingency	Waipio Tsf 1 <sup>(b)</sup>	2	Evening	1	Grid Need Oahu - F
Distribution Reliability	2023	Waiiau-Steel Mill 46 kV Circuit <sup>(c)</sup>	10	Evening	1	Grid Need Oahu - B
Distribution Reliability	2023	Waiiau-Mililani 46 kV Circuit <sup>(d)</sup>	10	Evening	1	Grid Need Oahu - C
Distribution Reliability	2023	Ewa Beach 2 - Ewa Beach 3 12 kV Circuit  Ocean Pointe 1 - Ocean Pointe 1 12 kV Circuit	3	Evening	1	Grid Need Oahu - G
Distribution Capacity	2024	Ewa Nui A Transformer <sup>(e)</sup>	2.7	Evening	1	Grid Need Oahu - D

<sup>2</sup> New service request is defined as a request made to the Company by an electrical contractor or electrical consultant that includes drawings, plans, electrical loading, and in-service information

Distribution Reliability	2026	Kamoku 2 - Kewalo 10 25 kV Circuit Kewalo 3 - Kewalo 6 25 kV Circuit	2.3	Both	0	Grid Need Oahu - E
Both	2025	Ho'opili <sup>(f)</sup>	10	Both	0	Grid Need Oahu – Area H

<sup>(a)</sup>Distribution Substations/Circuits: Kamokila 3-Kamokila 5 circuit, Kamokila 3-Kamokila 6 circuit, Kapolei 1-Kapolei 1 circuit, Kapolei 1-Kapolei 2 circuit, Kaloii 1-Kaloii 1 circuit, Kaloii 1-Kaloii 2 circuit , Kaloii 2-Kaloii 3 circuit, Kaloii 2-Kaloii 4 circuit, Fort Weaver 2-Fort Weaver 3 circuit, Fort Weaver 2-Fort Weaver 4 circuit, Ewa Beach 1-Ewa Beach 1 circuit, Ewa Beach 1-Ewa Beach 2 circuit, Ocean Pointe 2-Ocean Pointe 3 circuit, Ocean Pointe 2-Ocean Pointe 4 circuit , West Loch-Westloch 1 circuit

<sup>(b)</sup>Distribution Substation/Circuits: Waipio 1 – Waipio 1 circuit, Waipio 1 – Waipio 2 circuit

<sup>(c)</sup>Distribution Substations/Circuits: Kapolei 2 – Kapolei 3 circuit, Kapolei 2 – Kapolei 4 circuit, Fort Weaver 1 – Fort Weaver 1 circuit, Fort Weaver 1 – Fort Weaver 2 circuit

<sup>(d)</sup>Distribution Substations/Circuits: Waimalu 2-Waimalu 3 circuit, Waimalu 2-Waimalu 4 circuit, Upper Kipapa 1 – Kuahelani 1 circuit, Upper Kipapa 1 – Kuahelani 4 circuit, Kunia – Kunia circuit

<sup>(e)</sup>Distribution Substations/Circuits: Makakilo 2-Makakilo 2 circuit, Makakilo 2-Makakilo 4 circuit, Ewa Nui 1 – Ewa Nui 1 circuit, Ewa Nui 2 – Ewa Nui 2 circuit, Kunia Makai 1-Kunia Makai 1 circuit, Kunia Makai 1-Kunia Makai 2 circuit , Kunia Makai 2-Kunia Makai 3 circuit, Kunia Makai 2-Kunia Makai 4 circuit, Ewa Beach 2-Ewa Beach 3 circuit, Ewa Beach 2-Ewa Beach 4 circuit, Ocean Pointe 1-Ocean Pointe 1 circuit, Ocean Pointe 1-Ocean Pointe 2 circuit, Iroquois Pt - Iroquois circuit, Hoaeae 1-Leoole circuit, Hoaeae 1-Hoaeae 1 circuit, Waipahu 2-Wailani circuit, Waipahu 2-Mokuola circuit

<sup>(f)</sup> Distribution Substation/Circuits: Ewa Nui 2 – Ewa Nui 2 circuit, Kaloii 1 – Kaloii 2 circuit, Kamokila 2-Kamokila 4 circuit

**DRAFT**

**REQUEST FOR PROPOSALS**

**FOR**

**COMMUNITY-BASED RENEWABLE ENERGY TRANCHE 1**

**ISLAND OF O‘AHU**

DECEMBER 1, 2020

Docket No. 2015-0389

*Appendix P – Term Sheet for Large CBRE DC-  
Coupled Projects (PV + BESS)*

**[NOTE: Please refer to Exhibit 16 of the December 1, 2020 filing for the proposed Term Sheet for Large CBRE DC-Coupled Projects.]**



**Hawaiian  
Electric**